



CARDINAL[®]

**MECHANICAL PORTABLE
PLATFORM SCALES**

**with BEAM
SERIES 854F/954F
Owner's Manual**



INTRODUCTION

Thank you for purchasing our Cardinal Mechanical Portable Platform Scale with Beam, Series 854F/954F. Manufactured with Cardinal quality and reliability, this scale has been calibrated and tested before leaving our factory to ensure accuracy and dependability for years to come.

This manual is provided to guide you through the assembly and operation of your scale. Please read it thoroughly before attempting to assemble or operate your scale and keep it available for future reference.

This manual is for use with the following Series 854F/954F Scale models:

854F50P	854F100P	954F50K
854F50K	854F100K	954F100P
854F50PK	854F100PK	954F100PK

TABLE OF CONTENTS

UNPACKING	Page 2
SCALE ASSEMBLY DIAGRAM AND INSTRUCTIONS	Page 2
FINAL SEALING AND ADJUSTING INSTRUCTIONS	Page 3
SCALE OPERATION INSTRUCTIONS	Page 4
BASE ASSEMBLY PARTS DIAGRAM	Page 5
BASE ASSEMBLY PARTS LIST	Page 5
COLUMN ASSEMBLY PARTS DIAGRAM	Page 6
COLUMN ASSEMBLY PARTS LIST	Page 6
BEAM ASSEMBLY PARTS DIAGRAM	Page 8
BEAM ASSEMBLY PARTS LIST	Page 9
DOUBLE BEAM ASSEMBLY PARTS DIAGRAM	Page 10
DOUBLE BEAM ASSEMBLY PARTS LIST	Page 11

COPYRIGHT

All rights reserved. Reproduction or use, without expressed written permission, of editorial or pictorial content, in any manner, is prohibited. No patent liability is assumed with respect to the use of the information contained herein.

DISCLAIMER

While every precaution has been taken in the preparation of this manual, the Seller assumes no responsibility for errors or omissions. Neither is any liability assumed for damages resulting from the use of the information contained herein. All instructions and diagrams have been checked for accuracy and ease of application; however, success and safety in working with tools depend largely upon individual accuracy, skill, and caution. For this reason, the Seller is not able to guarantee the result of any procedure contained herein. Nor can they assume responsibility for any damage to property or injury to persons occasioned from the procedures. Persons engaging in the procedures do so entirely at their own risk.

UNPACKING

Remove your scale from its packing and inspect it for signs of damage such as exterior dents and scratches. Keep the carton and packing for return shipment or relocation if it should become necessary. It is the responsibility of the purchaser to file all claims for any damage or loss incurred during transit.

SCALE ASSEMBLY INSTRUCTIONS

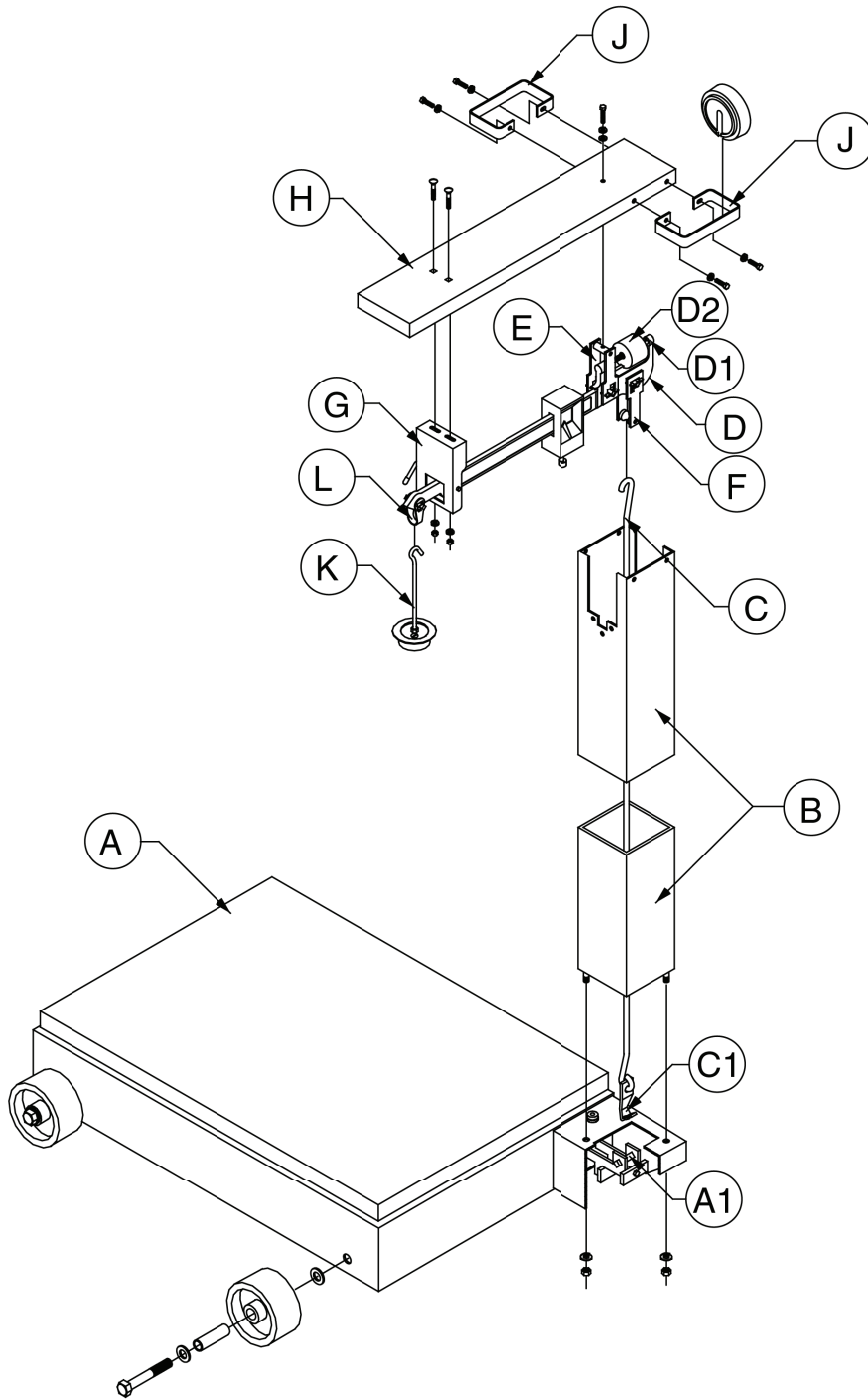

Figure No. 1
Scale Assembly Diagram

SCALE ASSEMBLY INSTRUCTIONS, CONT.

Refer to Figure No. 1 and follow the instructions below for scale assembly.

1. Assemble the wheels to the scale base with four 5/8-11 x 3 1/2" hex head bolts, four sleeves, and eight 5/8 flat washers. To secure the wheel, tighten the bolt against the sleeve to the scale base.
2. Insert column (B) into scale base assembly (A) and secure with two 3/8 split lock washers and two 3/8 -16 hex nuts. **NOTE:** Cardinal decal should be facing the platform.
3. Lower steelyard rod assembly (C) into column (B).
4. Hook hanger bearing (C1) into pivot (A1).
5. Column cap (H) may now be placed over column (B) together with weight racks (J). **NOTE:** If using only one weight rack, we recommend it be assembled to the back of the column. Secure with four 1/4 - 20 x 3/4" hex head bolts and four 1/4 split lock washers.
6. Attach trig loop (G) to column cap (H) with two 1/4 - 20 x 3/4" carriage bolts, two 1/4 split lock washers, and two 1/4 - 20 hexnuts.
7. Guide beam assembly (D) through the trig loop (G) and back into the column (B) opening.
8. Attach steelyard rod (C) onto the load loop assembly (F).
9. Secure the fulcrum loop assembly (E) to the column cap (H) with one 1/4-20 x 1" hex head bolt, one 1/4 split lock washer, and one 1/4 flat washer.
10. Hook counterpoise (K) into beam loop assembly (L).
11. Scale assembly is now complete.

FINAL SEALING AND ADJUSTING INSTRUCTIONS

1. Place capacity poise at Zero and move the balance ball (D2) to the center of the adjusting area by turning the zero adjust screw(D1).
2. Remove the screw from the counterpoise cup (K). Remove a sufficient amount of shot from the cup (K) until the scale is in balance. **NOTE:** Screw must be used as part of weight when removing shot.
3. Replace and tighten the screw into the counterpoise cup (K). **NOTE:** Beam must arc freely, otherwise, all bearings and hook connections must be rechecked for proper assembly. The scale is now ready for operation. (Note: Scale must be set up and operation must be on a level surface. The scale is level when the air bubble is in the target on the bulls-eye level.)

SCALE OPERATION INSTRUCTIONS

The following steps will guide you through the portable platform beam type scale operation.

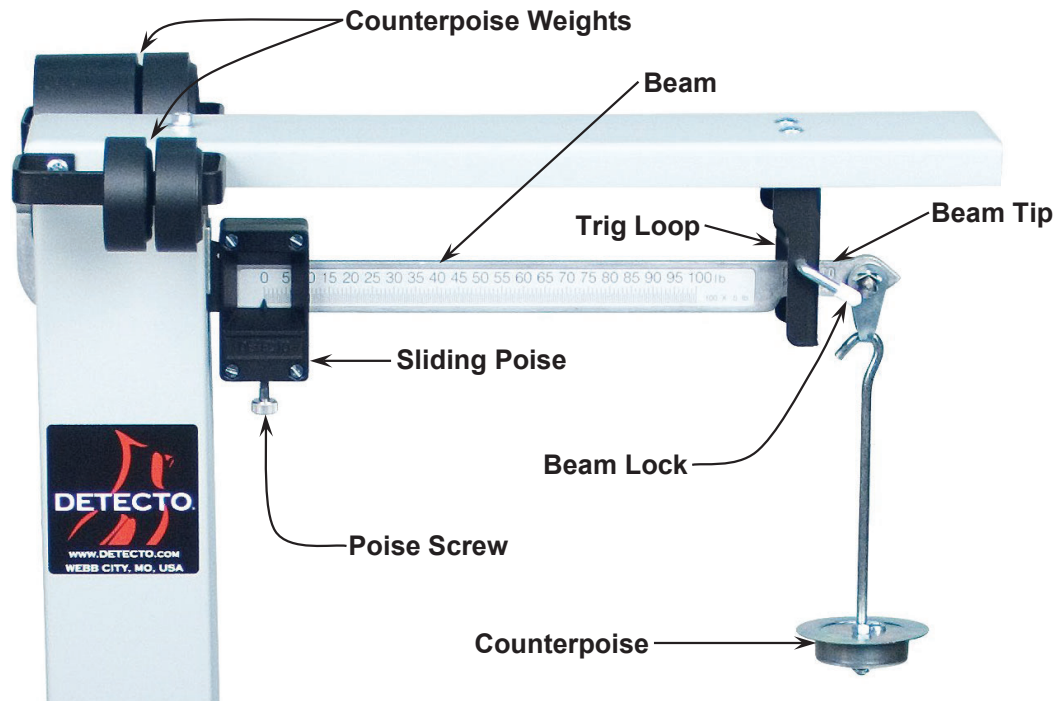

Figure No. 2
Portable Platform Beam Type Scale Operation Components

1. With no load on the scale platform, move the Sliding Poise to zero, and then unlock the Beam Lock. The Beam Tip should be centered vertically in the Trig Loop. If the tip is not centered, turn the Zero Adjust Screw until it is. See Figure No. 3.
2. Lock the Beam with the Beam Lock, and then place the item to be weighed on the scale platform.
3. Add Counterpoise Weights to an amount slightly less than the estimated weight of the item, and then release the Beam Lock.
4. The Beam should rise to the top of the Trig Loop. If it does not, reduce some of the Counterpoise Weights.
5. Next, move the Sliding Poise along the Beam until the Beam balances with the tip centered in the Trig Loop.
6. When the Beam balances, the weight of the item is the value indicated by the Sliding Poise, plus the face value of the Counterpoise Weights used.

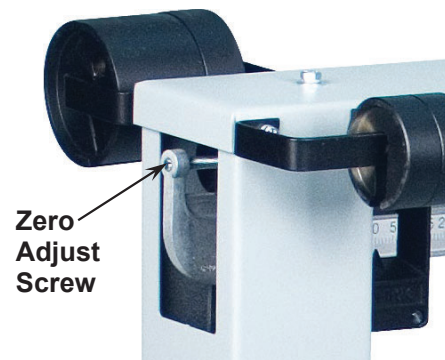

Figure No. 3
Zero Adjust Screw Location

For example, if there are two pounds of Counterpoise Weights (equivalent to 200 pounds) and the Sliding Poise on the Beam indicates 62.5 pounds, then the item on the scale platform weighs 262.5 pounds.

For a metric example, if there are two 1 kg Counterpoise Weights (equivalent to 200 kg) and the Sliding Poise on the Beam indicates 19.6 kg, then the item on the scale platform weighs 219.6 kg.

7. After the weight has been determined, lock the beam, and then remove the item from the scale platform.

NOTE: The Sliding Poise may be locked at the reading by tightening the Poise Screw if the desired weight is needed repeatedly, such as when filling propane tanks.

BASE ASSEMBLY PARTS DIAGRAM

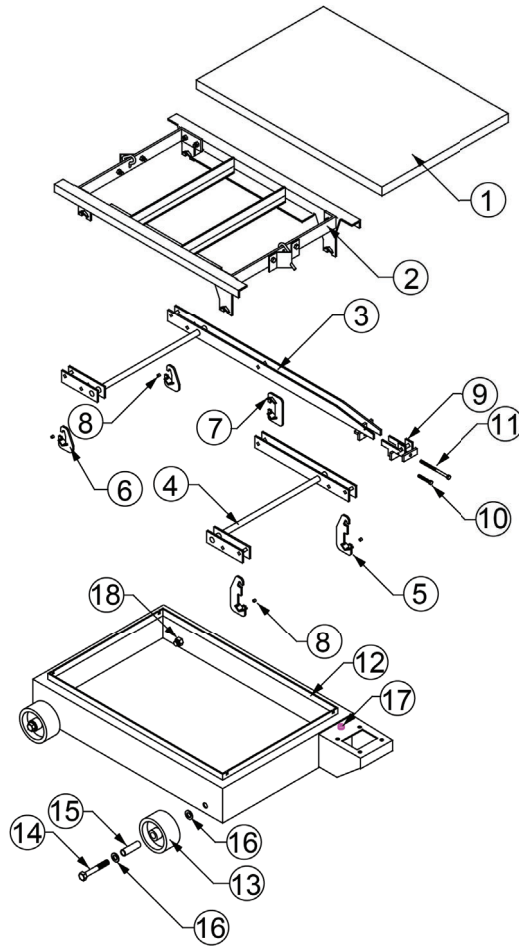

Figure Number 4
Base Assembly
Parts Diagram

BASE ASSEMBLY PARTS LIST

Item No.	854F Part No.	954F Part No.	Part Name	Qty.
1	0066-C017-08	0066-D057-0A	Deck Plate	1
2	0066-D012-0A	0066-D107-0A	Weighbridge Assembly	1
3	0066-D006-0A	0066-D060-0A	Long Lever Assembly	1
4	0066-D007-0A	0066-D061-0A	Short Lever Assembly	1
5	0066-B004-0A	0066-B004-0A	Long Hanger Assembly	2
6	0066-B005-0A	0066-B005-0A	Short Hanger Assembly	2
7	0066-B008-0A	0066-B008-0A	Center Hanger Assembly	1
8	0066-B003-08	0066-B003-08	Bearing	4
9	0066-B010-0A	0066-B010-0A	Nose Iron Assembly	1
10	6021-1458	6021-1458	5/16"-18UNC x 1 3/4" Hex Head Bolt	1
11	6021-1833	6021-1833	5/16"-18UNC x 4" Hex Head Bolt	1
12	0066-D002-0A	0066-D067-0A	Base Weldment	1
13	0066-B199-08	0066-B199-08	Wheels, 5" Diameter X 2" x 3/4" Bore	4
14	6007-0240	6007-0240	5/8"-11UNC x 3 1/2" Hex Head Bolt ZP	4
15	0066-B200-08	0066-B200-0A	Sleeve	4
16	6024-0015	6024-0015	5/8" ZP Flat Washer	8
17	6690-0001	6690-0001	Bullseye Level	1
18*	6013-0105	6013-0105	5/8"-11UNC-2B Hex Nut	4

* **NOTE:** On some models, item 18 (5/8"-11UNC-2B Hex Nut) is welded to the inside of item 12 (Base Weldment).

COLUMN ASSEMBLY PARTS DIAGRAM

Figure Number 5
Column Assembly Parts Diagram

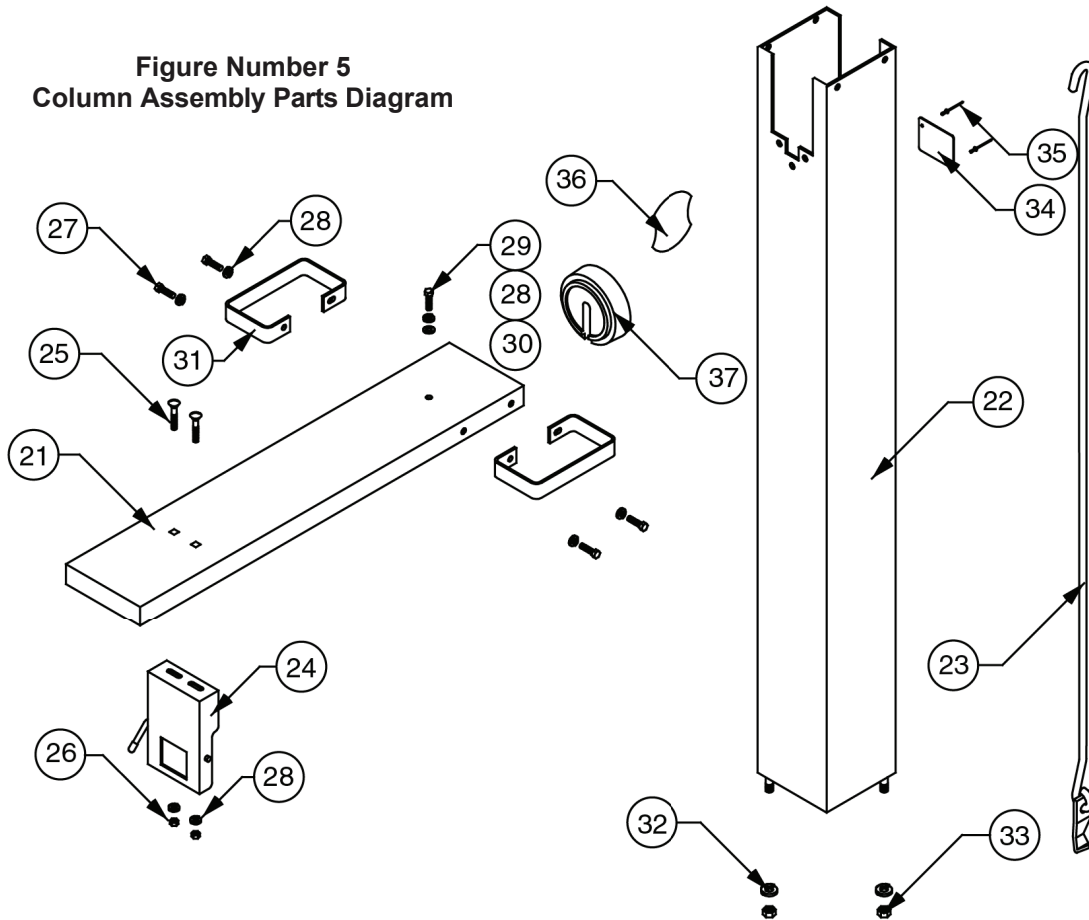

COLUMN ASSEMBLY PART LIST

Item No.	Part No.	Part Name	Qty.	Model No.
21	0066-C036-18	Column Cap	1	854F/954F
22	0066-C042-0A	Column Assembly	1	854F/954F
23	6P33X	Steelyard Rod Assembly	1	854F/954F
24	6P2009X	Trig Loop	1	854F/954F
25	345MV0406	1/4 - 20 X 3/4" Carriage Bolt	2	854F/954F
26	6013-0045	1/4 - 20 Hex Nut	2	854F/954F
27	6021-1454	1/4 - 20 x 3/4" Hex Head Bolt	4	854F/954F
28	6024-0039	1/4 Split Lock Washer	7	854F/954F
29	6021-1428	1/4-20 x 1" Hex Head Bolt	1	854F/954F
30	6024-0003	1/4 Flat Washer	1	854F/954F
31	6P1007	Weight Rack	*	854F/954F
32	6024-0045	3/8 Split Lock Washer	2	854F/954F
33	6P23	3/8 - 16 Hex Nut	2	854F/954F
34	593M729	Serial No. Plate	1	854F/954F
35	6680-0073	Pop Rivet	2	854F/954F
36	6PSS1002	Detecto Logo Decal	1	854F/954F

* 1 or 2 as required.

COLUMN ASSEMBLY PART LIST, CONT.

Item No.	Part No.	Part Name	Qty.	Model No.
37	6PP3000X	Weight Pack Assembly 1000lb	1	854F100P
	6PP3050X	Weight Pack Assembly 500lb	1	854F50P
	6PK2500X	Weight Pack Assembly 500kg	1	854F50K
	6PK2550X	Weight Pack Assembly 1000lb/500kg	1	854F100PK
	6PL1000X	Weight Pack Assembly 1000 libra/500kg	1	854FFS
	6PK10	Weight	1	
	0066-C241-1A	Weight	1	
	6PK20	Weight	1	
	0066-C239-1A	Weight	1	854F-50PK
	0066-C234-1A	Weight	1	
	0066-C236-1A	Weight	1	
	0066-C233-1A	Weight	1	
		500 lb/200 kg		
	0066-C234-1A	Weight	1	
	0066-C236-1A	Weight	2	954F100P
	0066-C237-1A	Weight	3	
		2000 lb/1000 lb		
	0066-C239-1A	Weight	1	
	0066-C241-1A	Weight	1	954F50K
	0066-C242-1A	Weight	4	
		1000 kg		
	0066-C239-1A	Weight	1	
	0066-C241-1A	Weight	1	
	0066-C242-1A	Weight	4	954FFS
	0066-C234-1A	Weight	1	
	0066-C236-1A	Weight	2	
	0066-C237-1A	Weight	3	
		2000 libra 2000 libra/ 1000 kg		

BEAM ASSEMBLY PARTS DIAGRAM

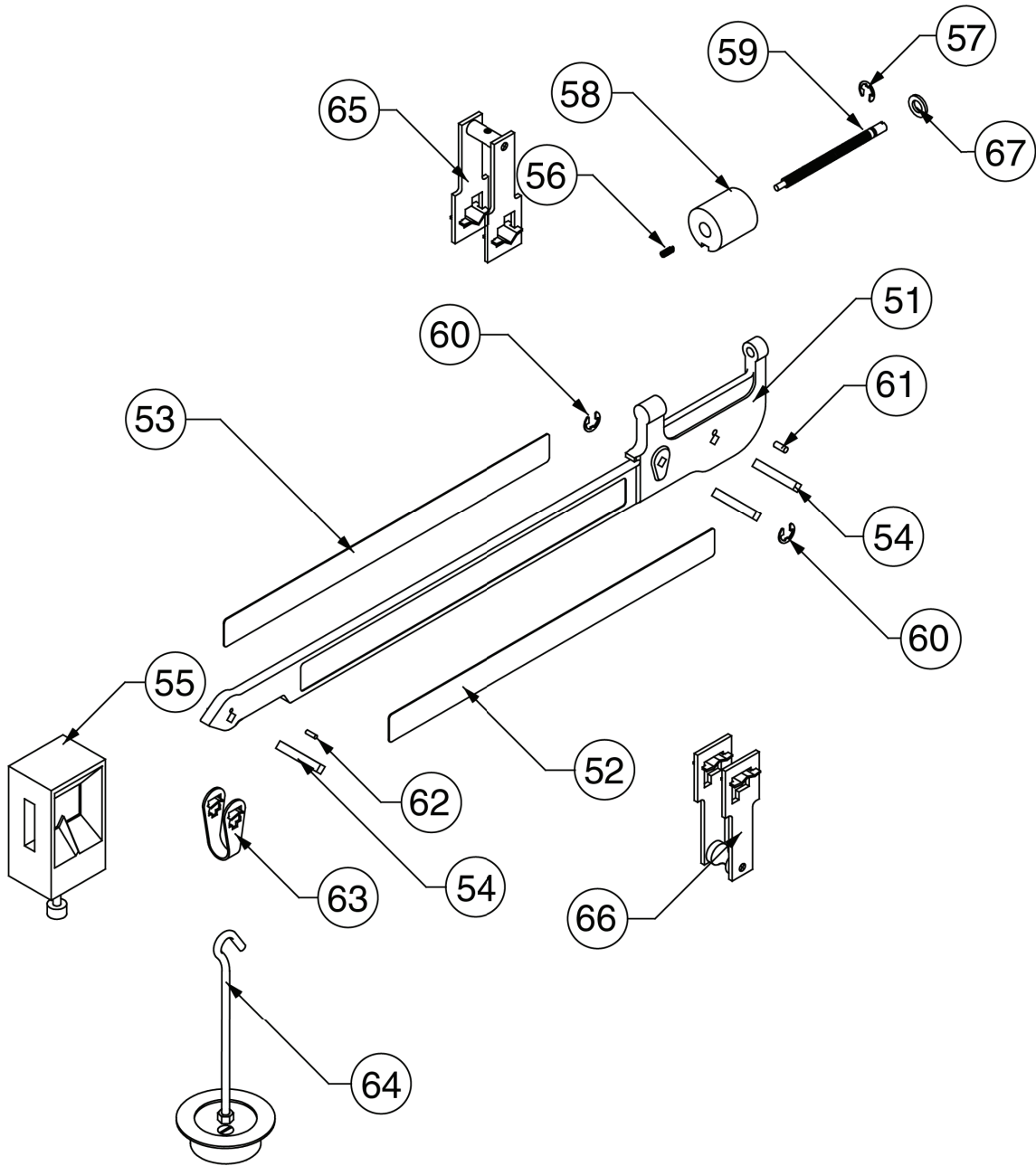

Figure Number 6
Beam Assembly Parts Diagram

BEAM ASSEMBLY PARTS LIST

Item No.	854F Part No.	954F Part No.	Part Name	Qty.	Model No.	
51	6P10037	6P10037	Beam	1		
52 & 53	6P11037	6P11037	Insert 100lb (Rear)	1	854F100P/954F100P	
	6P11137	6P11137	Insert 100lb (Front)	1	854F100P/954F100P	
	6P11042		Insert 50lb (Rear)	1	854F50P	
	6P11142		Insert 50lb (Front)	1	854F50P	
	6P11038	6P11038	Insert 50kg (Rear)	1	854F50K/954F50K	
	6P11138	6P11138	Insert 50kg (Front)	1	854F50K/954F50K	
	6P11044		Insert 20kg (Rear)	1	854F50PK	
	6P11142		Insert 50lb (Front)	1	854F50PK	
	6P11043		Insert 100lb (Rear)	1	854F100PK	
	6P11138		Insert 50kg (Front)	1	854F100PK	
	6P11039	6P11039	Insert 100 libra (Rear)	1	854FFS/954FFS	
	6P11138	6P11138	Insert 50kg (Front)	1	854FFS/954FFS	
	54	0066-B040-08	0066-B040-08	Pivot	3	
	55	0066-D112-0A	0066-D112-0A	Poise Assembly	1	854F100P/954F100P
6P1031X		6P1031X	Poise Assembly	1	854F50P 854F50PK	
0066-D112-3A		0066-D112-3A	Poise Assembly	1	854F50K/954F50K 854F100PK 854FFS/954FFS	
56	2P60	2P60	Adjusting Spring	1		
57	6029-0032	6029-0032	Snap Ring	1		
58	6P27	6P27	Balance Weight	1		
59	6P22	6P22	Adjusting Screw	1		
60	6029-0022	6029-0022	Snap Ring	2		
61	6P72	6P72	Pin	1		
62	6P74	6P74	Pin	1		
63	0066-C041-1A	0066-C041-1A	Beam Loop Assy	1		
64	6P10021X	0066-B109-0A	Counter Poise Assy	1		
65	0066-B126-1A	0066-B126-1A	Fulcrum Loop Assy	1		
66	0066-B125-0A	0066-B125-0A	Load Loop Assy	1		
67	6024-1043	6024-1043	Washer Nylon	1		

DOUBLE BEAM ASSEMBLY PARTS DIAGRAM

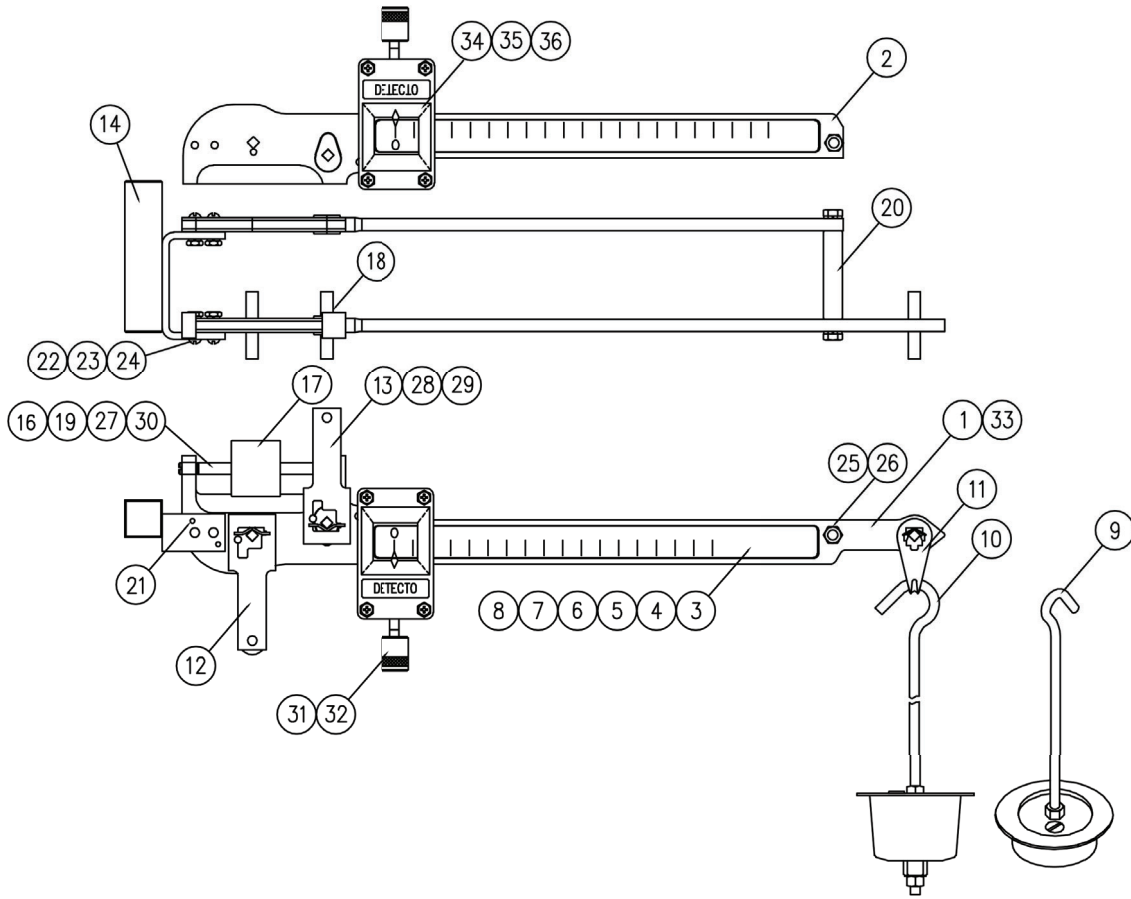

Figure Number 7
Double Beam Assembly Parts Diagram

DOUBLE BEAM ASSEMBLY PARTS LIST

(Assembly for avoirdupois, unit available in metric)

Only 1700 Demountable Heads can be used with these scales.

Item No.	Part No.	Part Name	Qty.
1	6P7037X	Beam W/Pivots	1
2	6P6042	Tare Beam	1
3	6P11138	Insert 50K Front	2
4	6P11038	Insert 50K Rear	2
5	6P11137	Insert 100P Front	2
6	6P11037	Insert 100P Rear	2
7	6P11142	Insert 50P Front	2
8	6P11042	Insert 50P Rear	2
9	6P10021X	C-Poise Assy.	1
10	0066-B109-0A	C-Poise Assy.	1
11	0066-C041-1A	Beam Loop Assy.	1
12	0066-B125-0A	Load Loop Assy.	1
13	0066-B126-1A	Fulcrum Loop Assy.	1
14	6P166X	Balance Wt. Assy.	1
15	6560-1061	Loctite #262 or Equal	A/R
16	6P22	Adjusting Screw	1
17	6P27	Balance Weight	1
18	6029-0022	E-Ring 3/8"	2
19	6029-0032	E-Ring 5/16"	1
20	6P167	Spacer	1
21	548R590810	Roll Pin	4
22	6013-0295	Nut Hex #10-32	4
23	6021-1001	Screw Round Head #10-32	4
24	6024-1010	Washer Lock #10	4
25	6021-1454	Screw Hex Head 1/4-20	2
26	6024-0039	Washer Lock 1/4	2
27	6024-1043	Washer Flat 5/16	1
28	6007-0011	Bolt Hex Head 1/4-20	1
29	6024-0003	Washer Flat 1/4	1
30	2P60	Spring	1
31	6P1065	Poise Screw	REF
32	6P65X	Poise Screw Assy	REF
33	6P5042X	Beam W/Pivots	1
34	0066-D112-0A	Poise Assy (Uses Item 32)	2
35	6P1031X	Poise Assy Alum (Uses Item 31)	1
36	0066-D112-3A	Poise Assy (Uses Item 32)	1

STATEMENT OF LIMITED WARRANTY

WARRANTY TERMS

Cardinal Scale Manufacturing Company warrants the equipment we manufacture against defects in material and workmanship. The length and terms and conditions of these warranties vary with the type of product and are summarized below:

PRODUCT TYPE	TERM	MATERIAL AND WORKMANSHIP	LIGHTNING DAMAGE See note 9	WATER DAMAGE See note 7	CORROSION See note 4	ON-SITE LABOR	LIMITATIONS AND REQUIREMENTS
WEIGHT INDICATORS	90 DAY REPLACEMENT ----- 1 YEAR PARTS	YES	YES	YES	YES	NO	1, 2, 3, 5, 6 A, B, C, D
LOAD CELLS (Excluding Hydraulic)	1 YEAR	YES	YES	YES	YES	NO	1, 2, 3, 5, 6 A, B, C, D
HYDRAULIC LOAD CELLS (When purchased with Guardian Vehicle Scale)	LIFETIME	YES	YES	YES	YES	90 DAYS	1, 5, 6, 8 A, B, C, D
HYDRAULIC LOAD CELLS (When purchased separately)	10 YEARS	YES	YES	YES	YES	NO	1, 5, 6, 8, 9 A, B, C, D
VEHICLE SCALE (Deck and Below Excl. PSC Series)	5 YEARS	YES	YES	YES	YES	90 DAYS	1, 2, 3, 5, 6 A, B, C, D, E
LSC SCALE (Deck and Below)	3 YEARS	YES	YES	YES	YES	90 DAYS	1, 2, 3, 5, 6, 11 A, B, C, D
GUARDIAN FLOOR SCALES	10 YEARS	YES	YES	YES	YES	NO	1, 2, 3, 5, 6, 9, 10 A, B, C, D
ALL OTHER CARDINAL PRODUCTS	1 YEAR	YES	YES	YES	YES	NO	1, 2, 5, 6 A, B, C, D, E
REPLACEMENT PARTS	90 DAYS	YES	YES	YES	YES	NO	1, 2, 4, 5, 6 A, B, C, D
SWIM AND 760 SERIES VEHICLE SCALES	1 YEAR	YES	YES	YES	YES	90 DAYS	1, 2, 5, 6 A, B, C, D
SOFTWARE	90 DAYS	YES	N/A	N/A	N/A	NO	1, 6 B, C, D
CONVEYOR BELT SCALES (including Belt-Way)	1 YEAR	YES	YES	YES	YES	NO	1, 2, 3, 5, 6 A, B, C, D, E, F



CARDINAL

Ph. (800) 441-4237
E-mail: cardinal@cardet.com
102 E. Daugherty
Webb City, MO 64870

04/24
Printed in USA
315-WARRANTY-CAR-M

APPLICABLE LIMITATIONS AND REQUIREMENTS

1. This warranty applies only to the original purchaser. The warranty does not apply to equipment that has been tampered with, defaced, damaged, or had repairs or modifications not authorized by Cardinal or has had the serial number altered, defaced or removed.
2. This warranty is not applicable to equipment that has not been grounded in accordance with Cardinal's recommendations.
3. This equipment must be installed and continuously maintained by an authorized Cardinal / Belt-Way dealer.
4. Applies only to components constructed from stainless steel.
5. This warranty does not apply to equipment damaged in transit. Claims for such damage must be made with the responsible freight carrier in accordance with freight carrier regulations.
6. Warranty term begins with date of shipment from Cardinal.
7. Only if device is rated NEMA 4 or better or IP equivalent.
8. Lifetime warranty applies to damages resulting from water, lightning, and voltage transients and applies only to the hydraulic load cell structure itself (does not include pressure transducers, rubber seals, o-rings, and associated wiring).
9. 10-Year prorated warranty on hydraulic load cells.
10. 1-Year warranty for scale structure.
11. PSC models' warranty coverage applies only to agricultural installations on farms up to 3,000 acres (LSC models not limited in this manner).
12. Load cell kits MUST be installed in accordance with Cardinal Scale instructions. Failure to follow these instructions will void the warranty.

EXCLUSIONS

- A.) This warranty does not include replacement of consumable or expendable parts. The warranty does not apply to any item that has been damaged due to unusual wear, abuse, improper line voltage, overloading, theft, fire, water, prolonged storage or exposure while in purchaser's possession or acts of God unless otherwise stated herein.
- B.) This warranty does not apply to peripheral equipment not manufactured by Cardinal. This equipment will normally be covered by the equipment manufacturer's warranty.
- C.) This warranty sets forth the extent of our liability for breach of any warranty or deficiency in connection with the sale or use of our product. Cardinal will not be liable for consequential damages of any nature, including but not limited to loss of profit, delays or expenses, whether based on tort or contract. Cardinal reserves the right to incorporate improvements in material and design without notice and is not obligated to incorporate said improvements in equipment previously manufactured.
- D.) This warranty is in lieu of all other warranties expressed or implied including any warranty that extends beyond the description of the product including any warranty of merchantability or fitness for a particular purpose. This warranty covers only those Cardinal products installed in the forty-eight contiguous United States and Canada.
- E.) This warranty does not cover paint coatings due to the variety of environmental conditions.
- F.) Do not cut load cell cables on load cells returned for credit or warranty replacement. Cutting the cable will void the warranty.
- G.) Software is warranted only for performance of the functions listed in the software manual and/or the Cardinal proposal.
- H.) The software warranty does not cover hardware. Warranties on hardware are provided from the hardware vendor only.
- I.) The software warranty does not cover interfacing issues to non-Cardinal supplied hardware.
- J.) The software warranty does not include automatic software upgrades unless purchased separately.



Ph. (800) 441-4237
E-mail: cardinal@cardet.com
102 E. Daugherty
Webb City, MO 64870

04/24
Printed in USA
315-WARRANTY-CAR-M

Cardinal Scale Mfg. Co.

102 E. Daugherty, Webb City, MO 64870 USA

Ph: 417-673-4631 or 1-800-641-2008

Fax: 417-673-2153

www.cardinalscale.com

Technical Support: 1-866-254-8261

E-mail: tech@cardet.com

Printed in USA

0066-M110-O1 Rev K 11/22