



Digital Truck Scale Installation Manual

Copyright

All rights reserved. Reproduction or use, without expressed written permission, of editorial or pictorial content, in any manner, is prohibited. No patent liability is assumed with respect to the use of the information contained herein.

Disclaimer

While every precaution has been taken in the preparation of this manual, the Seller assumes no responsibility for errors or omissions. Neither is any liability assumed for damages resulting from use of the information contained herein. All instructions and diagrams have been checked for accuracy and ease of application; however, success and safety in working with tools depend largely upon the individual accuracy, skill and caution. For this reason, the Seller is not able to guarantee the result of any procedure contained herein. Nor can they assume responsibility for any damage to property or injury to persons occasioned from the procedures. Persons engaging the procedures do so entirely at their own risk.

FCC Compliance Statement

This equipment generates uses, can radiate radio frequency, and if not installed and used in accordance with the instruction manual, may cause interference to radio communications. It has been designed within the limits for a Class A computing device pursuant to Subpart J of Part 15 of FCC rules to provide reasonable protection against such interference when operated in a commercial environment. Operation of this equipment in a residential area may cause interference in which case the user will be responsible to take whatever measures necessary to correct the interference.

You may find the booklet "How to Identify and Resolve Radio TV Interference Problems" prepared by the Federal Communications Commission helpful. It is available from the U.S. Government Printing Office, Washington, D.C. 20402. Request stock No. 001-000-00315-4.

Serial Number _____
Date of Purchase _____
Purchased Form _____

RETAIN THIS INFORMATION FOR FUTURE USE

PRECAUTIONS	
Before using this product, read this manual and pay special attention to all "NOTIFICATION" symbols:	
	DANGER! WARNING! CAUTION!

TABLE OF CONTENTS

INTRODUCTION AND SITE REQUIREMENTS

Introduction	1
Site Preparation Requirements	2
Electrical Power	2
AC Power Fluctuations	3
Power Source	3
Voltage	4
Frequency	4
Grounding	4
AC Neutral	4
Safety Considerations	5
Lightning Protection	5
Heating and Cooling	5
Scale Site	5

INSTALLATION

Installation	7
Foundation Verification	7
Bridge Module Installation	8
Lifting Steel Decks	8
Lifting Concrete Decks	8
Optional Lifting Lugs on Steel Decks	9
Load Cells and Load Cell Stands	9
Bridge Module Installation with Separately Shipped Load Cell Stands	13
Lifting Steel Decks	13
Lifting Concrete Decks	14
Optional Lifting Lugs on Steel Decks	14
Install Load Cell Stand Anchor Bolts	19
Install Load Cell Cables	21
Concrete Scale Deck Specifications and Installation (SPEC. #0104-A020-ES)	23
1. Concrete Specifications	23
2. Placing of Concrete	23
3. Finishing Concrete Decks	24
4. Curing Concrete Decks	25

TABLE OF CONTENTS, CONT.

HOMERUN CABLE INSTALLATION

Homerun Cable Installation	27
Power DLC to Scale Connection	29
Power DLC to Indicator DLC Card Connection	30
Re-Installing the Power DLC Cover	30
Power DLC to 225D Indicator Connection	31
225DLC Card ICAN Jumpers	33
Re-Installing the 225D Indicator Rear Panel	33
Power DLC to 825D Indicator Connection	34
825DLC Card ICAN Jumpers	36
Re-Installing the 825D Indicator Rear Panel	36
Load Cell to Power DLC Connection	37

GROUNDING INSTRUCTIONS

SCBD Scales Grounding Specifications – 3502-0671-GS	41
Truck Scale Grounding Specifications – 3502-0713-GS	42
Grounding Instructions for ARMOR Digital Truck Scales	43
Site Requirements	43
Indicator and Scale Lightning Protection Connections	43
Scale Ground Stud to Ground Rod Connections	44

RODENT GUARD INSTALLATION

Rodent Guard Installation	45
12-Inch Beam Steel Deck Installation	46
8-Inch Beam Concrete Deck Installation	53
10-Inch beam Concrete Deck Installation	60

DIGITAL SCALE SETUP AND CONFIGURATION

Digital Scale Setup and Configuration	67
225D Setup and Configuration	68
Addressing Cells	68
End Nodes	68
225D Calibration	69
Navigating to the DLC Calibration Menu	69
Smart Calibration	70
Zero Calibration	70
Trim Cells	71
Span Adjust	71

TABLE OF CONTENTS, CONT.

SCALE SETUP AND CONFIGURATION, CONT.

825D Setup and Configuration	73
Login	74
Setup Scale Number	75
Setup DLC Card 1	76
Setup DLC Card 1 – Advanced Screen	78
DLC Card 1 Cell Assignment	81
Assign Cell	82
Smart Calibration	85
Zero Calibration	94
Trim Cells	97
Section Trim Mode	98
Single Cell Mode	99
Span Adjust	103

WEIGHBRIDGE DEAD LOAD

Balancing the Weighbridge Dead Load	107
---	-----

DIGITAL SCALE DIAGNOSTICS

225D Digital Scale Diagnostics	109
On Screen Diagnostics	109
Diagnostic Menu	114
Hardware Diagnostics	118
Detecting 225D Board Replacements	119
225DLC Digital Controller Card Replacement	120
225DLC Controller (Digital Scale) Card	122
825D Digital Scale Diagnostics	125
On Screen Diagnostics	125
Diagnostic Menu	129
Hardware Diagnostics	141
Detecting 825D Board Replacements	142
825-DLC Digital Controller Card Replacement	144
825DLC Controller (Digital Scale) Card	146

MAINTENANCE INSTRUCTIONS

Maintenance Instructions for High Usage Weighments	149
--	-----

TABLE OF CONTENTS, CONT.

TROUBLESHOOTING GUIDE

DISPLAYED ERROR MESSAGES	151
REPLACE LOAD CELL X	151
LOAD VOLTAGE DETECTED CELL X	151
CURRENT DRAW MORE THAN 150% OF CAPACITY	153
LOAD CELL X NOT RESPONDING	154
COMMUNICATIONS ERROR BETWEEN INDICATOR AND SCALE	154
LOAD CELL X HAS NO ADDRESS	156
COMMUNICATION ERROR BETWEEN LOADCELLS X AND Y	156
SCALE WILL NOT RETURN TO ZERO	156
SCALE IS UNSTABLE	156
LOAD CELL OR SCALE COMMUNICATION PROBLEMS	157

ISITE CONFIGURATION

225D iSite Configuration	159
To Check the Status of the Last iSite Connection	159
825D iSite Configuration	161
iSite Status of Last Connection	162
Enter Valid SO Identifier for iSite	163
Successful Comm Establish for iSite	163

PARTS IDENTIFICATION

Load Cell Top View Detail	166
Load Cell Stand and Parts Detail	167
Load Cell Interconnect Cables	168
Components Included in 3502-0681-0A	168
Load Cell Shims	168
Included Grounding Components	169
Optional Lifting Lug	169
Rodent Guard Sub-Assemblies for 12-inch Beam Steel Deck	170
Rodent Guard 12-inch Beam Steel Deck Cross Section View	170
Rodent Guard Sub-Assemblies for 8-inch Beam Concrete Deck	171
Rodent Guard Sub-Assemblies for 10-inch Beam Concrete Deck	172
Rodent Guard 8-inch and 10-inch Beam Concrete Deck Cross Section View	173

INTRODUCTION AND SITE REQUIREMENTS

Introduction

The Cardinal ARMOR® Digital Truck Scale provides you with superior-strength, long-life full-length steel I-beam structural member construction for optimum vehicle weighing. It is a versatile scale that is designed to be installed above ground or in a pit with all required components installed from the top through small no-bolt access covers. The NTEP legal-for-trade Armor® arrives fully prepared for installation and includes Cardinal Scale's SmartCell® digital load cells and AXIS® heavy duty load cell stands with Frictionless Centering. A wide selection of capacities, platform sizes, and types are available. Each scale module features interconnecting load blocks and receivers for an efficient, no-bolt installation. Enhanced rodent protection is standard throughout the scale using braided wiring and conduit integral in each scale module. Every Armor® digital truck scale is 100% assembled, pre-calibrated, and tested before shipping.



This manual must be used in conjunction with certified drawings of the truck scale model being installed. ***In case of conflict, the certified drawings will govern.***

This manual should be studied thoroughly (and kept available) before attempting to install either the Steel or Concrete Digital Truck Scale. Safety should always be the prime consideration during all phases of the installation. Failure to comply with the instructions in this manual will void all warranty implied or stated.

Site Preparation Requirements

Your new scale, as with any precision measuring instrument, requires an acceptable environment to operate at its peak performance and reliability. The purpose of this section is to explain how the user can provide such an environment.

Electrical Power

Most Cardinal instrumentation is designed to operate at 115 VAC, 50/60 Hz. Where required, the equipment may be ordered for operation at 230 VAC, 50/60 Hz. Refer to your order confirmation copy or the equipment nameplate if you are not certain for which voltage level your scale is configured.

Power Outlet

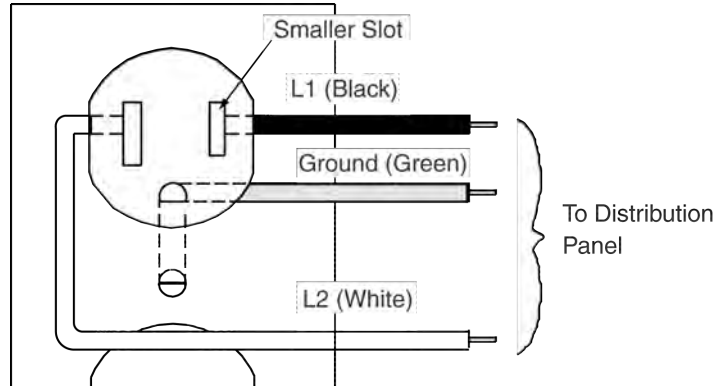

Your weighing system will require one or more power outlets. Refer to Table A to determine the number of power outlets necessary for your system. These outlets should be of the grounded, polarized type as shown above. One additional outlet is recommended to allow a source of power for test equipment to be used during installation and service.

Device	Outlets Required
Weight-Indicating Instrument	1
Printer	1
Fill Control Console	1
Traffic Control Console	1
Regulating Transformer*	1
Computer	1

*This piece of optional equipment eliminates the need for an outlet for the weight-indicating instrument, depending on the type of regulating transformer.

Table A – Power Outlet Requirements

The figure to the right illustrates typical wiring from the distribution panel to the power outlets used for the weighing system.

Power outlets should be on a separate circuit from the distribution panel. This circuit should be dedicated to the exclusive use of the weighing system. The power wiring should conform to local electrical codes. Services of a qualified contractor and approval by the local building inspector generally will assure compliance with this code.

To prevent electrical noise interference, make certain that all other wall outlets for use with vacuum cleaners, lighting, industrial machinery, and other equipment are on circuits separate from that used for the weighing system.

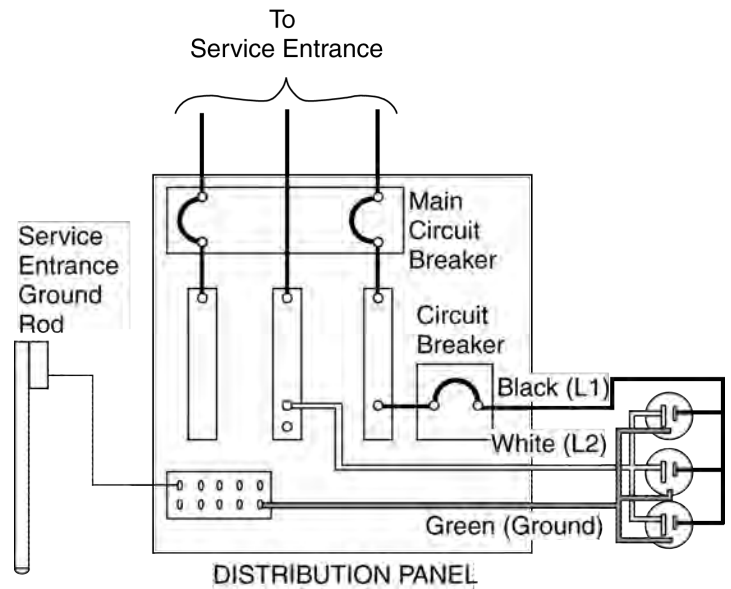

Typical Power Outlet Wiring

AC Power Fluctuations

Your Cardinal Weighing System uses one or more microcomputer systems. Many of the problems associated with computer operations are caused by fluctuations in the AC power system. Electrical noise, power interruptions, and lightning effects from the commercial power line may enter the weighing system and cause equipment failures.

Many of the disturbances that can seriously affect the operation of a weighing system originate within the building itself. These disturbances result from switching heavily inductive loads, such as welders, motors, and solenoids. These sources of disturbances must be identified, and steps taken to prevent possible adverse effects on the operation of the weighing system. Examples of available alternatives include isolation transformers, power regulators, uninterruptible power supplies, or simple line filters.

Power Source

The power source should have sufficient capacity to supply the weighing system load. Consideration should be given to adding extra capacity to provide for the additional loads caused by the expansion of your system. Make certain this source is independent of other loads (i.e., air conditioning and heating equipment, convenience outlets, lighting, or office equipment, which can cause disturbances). A separate line back to the distribution panel usually provides suitable power. Make certain that a properly sized circuit breaker is installed in this line to safeguard against accidental short circuits.

Table B provides some basic guidelines in the selection of a power-conditioning device, should it be necessary to use one. Remember that this is only a guide and that a qualified technician should be consulted for the determination of the type of device suited to your application. All the types listed are available in various sizes from Cardinal Scale or may be purchased locally.

PROVIDES PROTECTION AGAINST				
Type	Outages	Transients	Fluctuations	Cost
Uninterruptible Power Supply	✓	✓	✓	High to Moderate
Voltage Regulator		✓	✓	Moderate
Isolation Transformer		✓		Low to Moderate
Line Filters		✓		Low

Table B – Power Conditioning Device

Voltage

Voltage (steady-state) variations shall not exceed plus (+) 10 percent or minus (-) 15 percent of the nominal value 115 VAC (plus or minus 8 percent for 230 VAC).

Transient variation (step or slope) changes of plus (+) or minus (-) 20 percent on the nominal value shall exist no longer than 0.1 second and occur no more than once every 10 seconds.

Frequency

The equipment is designed to operate at a nominal 50/60 Hertz unless specified otherwise on the equipment nameplate. The steady-state harmonic distortion should be equal to, or less than, 6 percent of the fundamental frequency amplitude.

Grounding

A ground wire must be included with the power conductors (phase or L1 and neutral or L2 wires) in the run from the distribution panel to the weighing system power outlets. The size of the ground wire must comply with The National Electrical Code or local electrical code. The ground conductor must be securely bonded to the building's grounding electrode conductor. Refer to Grounding Installation Instructions for the scale and instrument.

	<p>CAUTION! A broken or high resistance safety ground is a potentially lethal situation. Because of line-to-chassis voltage potential, it is possible to receive a shock by touching the equipment if the green wire ground is not intact. Please be sure proper grounding is connected!</p>
---	---

AC Neutral

The AC neutral must not be confused with protective (equipment chassis) ground. As a protection for personnel, the protective equipment ground (the green wire in power line wiring) prevents the build-up of dangerous voltages on equipment. It ensures that a short circuit between L1 and the enclosure draws enough current to trip the circuit breaker immediately, rather than raising the voltage on the enclosure to a dangerous level. Do not substitute the neutral wire for the protective ground.

Safety Considerations

Safety must be a consideration in the selection of a location for your weighing system. DO NOT locate your system in an area where flammable or explosive materials are stored or processed unless your equipment is furnished in special explosive-proof enclosures. The equipment should be placed where it does not interfere with entry to or exit from the room. Periodic reviews should be made to make certain that the installation remains safe.

Lightning Protection

In areas subject to lightning strikes, certain steps must be taken by the customer to minimize the potential for lightning damage. These steps consist of the installation of lightning arresters as required by Article 280 of The National Electrical Code, the installation of a scale grounding system as described in Grounding Installation Instructions, and other surge arresting devices.

Heating and Cooling

Most standard Cardinal weighing system instrumentations are designed for the office environment. Such an environment is free of excessive dust and moisture and provides a comfortable temperature. In general, weighing equipment will perform well over a temperature range of 14° to 104° F. Some types of instruments and special systems will perform over a much wider range of temperatures.

To keep equipment cooling requirements to a minimum, the equipment should be placed out of direct sunlight and in an area where the air is free to flow around all sides of the system enclosure(s). Make certain that the enclosure is not in line with a heating or cooling vent. Such a location will subject the instrument to sudden temperature excursions and may result in an unstable weight reading.

Care should be exercised by providing a relatively dust-free environment for the operation of the printer. Accumulations of dust and dirt within the printer act as abrasives and as insulators that reduce the dissipation of heat from internal components. Accumulated dust and dirt can result in premature failure.

Scale Site

The site selected for installation of the scale should provide easy access, satisfactory soil bearing capacities, adequate drainage, and be within sight of the system operator. Refer to the foundation or pit drawings furnished for soil bearing requirements.

A common source of problems is the accumulation of water under and around the scale. Despite the best waterproofing techniques, prolonged exposure to water will result in erratic weight readings and may permanently damage the scale. In areas subject to water accumulation, an inexpensive alternative is to install a sump pump to remove excess water. Remember that power wiring for the sump pump must be contained in a conduit apart from the load cell conduit and separated from it a minimum of 24 inches.

Scale Site, Cont.

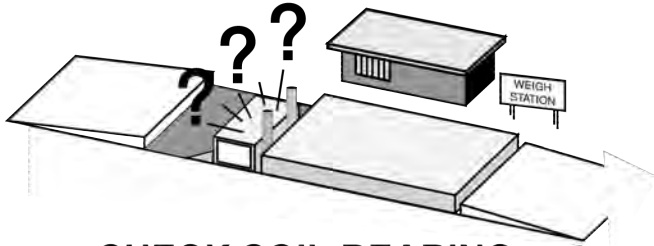

CHECK SOIL BEARING CAPABILITY

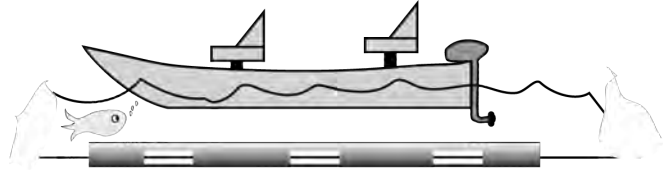

PROVIDE ADEQUATE DRAINAGE

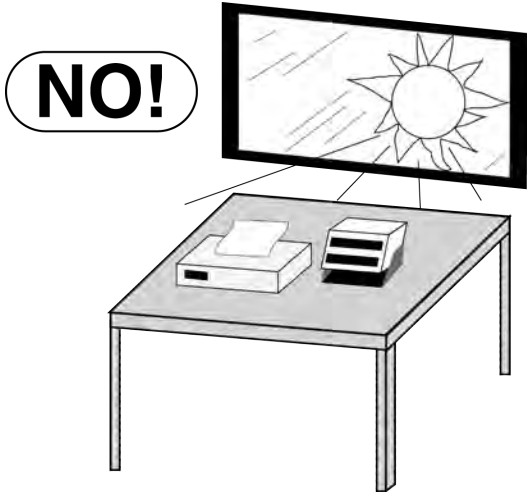

DON'T EXPOSE TO DIRECT SUNLIGHT

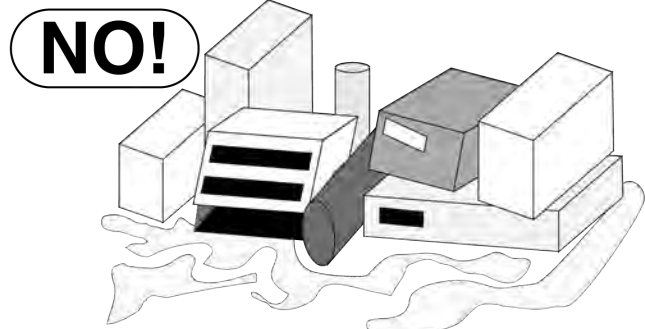

KEEP THE AREA AROUND THE SCALE CLEAR TO PROVIDE ADEQUATE AIR CIRCULATION



DON'T PLACE IN FRONT OF HEATING/COOLING VENTS

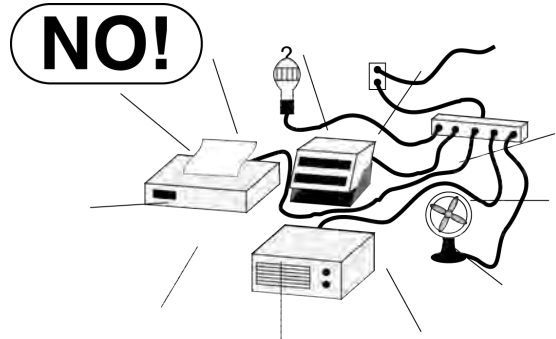

PROVIDE GOOD, SAFE GROUND AND CLEAN AC POWER

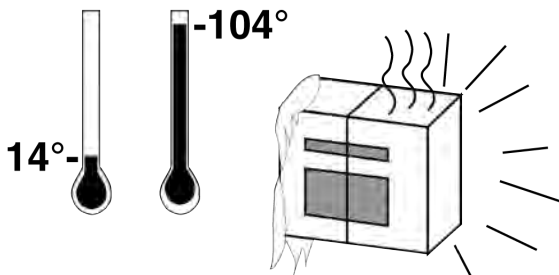

DON'T EXPOSE TO TEMPERATURE EXTREMES



PROVIDE ADEQUATE PROTECTION TO MINIMIZE LIGHTNING DAMAGE

INSTALLATION

Installation

At this point, the foundation should be in place as specified on the certified foundation drawing.



Foundation Verification

Begin the installation procedure by verifying that the following items have been cast in the concrete foundation and have been properly located per the certified foundation drawing:

- Ground rod (*install through the pier, prior to pouring concrete*)
- Transmission cable conduit (1 1/2" minimum)
- Coping angle assembly

The top of piers must be smooth and level within $\pm 1/8"$ (all piers are to be within $1/4"$).

NOTE: Make sure the concrete piers are clear of debris and rough spots before setting modules in place.

Clear the pier of rough spots and debris.



Bridge Module Installation

The Armor digital truck scale modules are shipped pre-assembled and ready to be placed into position on a prepared and level site. Refer to Final Assembly Drawing.

Lifting Steel Decks

Steel deck scale modules can be lifted by attaching straps, cables, or chains to each module. The hook-on and hook-end bridges have an additional guide rail bracket (*with 1-inch diameter holes*) to be used for the sole purpose of being a lifting bracket to allow balancing the bridge equally and to offset the weight of load cell stands only on one end of the bridge when being lifted by a crane. The additional lifting brackets are on the opposite end from the load cell stands in hook-on and hook-end bridges and are located just inside the outer guide rail bracket.

Because the end bridges are already balanced equally from end-to-end with four load cell stands installed, they don't have the additional lifting bracket. They should be lifted using the guide rail brackets on the module.



Hook-on and hook-end bridges have an additional guide rail bracket to be used when lifting by a crane.

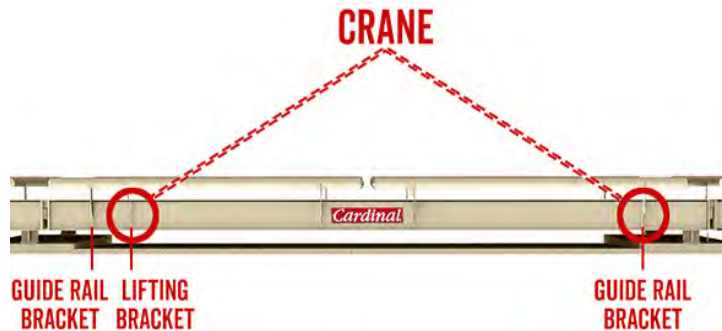

The additional brackets allow balancing the bridge equally and offset the weight of the load cell stands only on one end.

Lifting Concrete Decks

Concrete deck scales have lifting lugs integral to all modules. They can be lifted by attaching straps, cables, or chains to the lifting lugs built into the frame. Refer to the Final Assembly Drawing.

Modules for concrete scale decks have lifting lugs built into the frame.

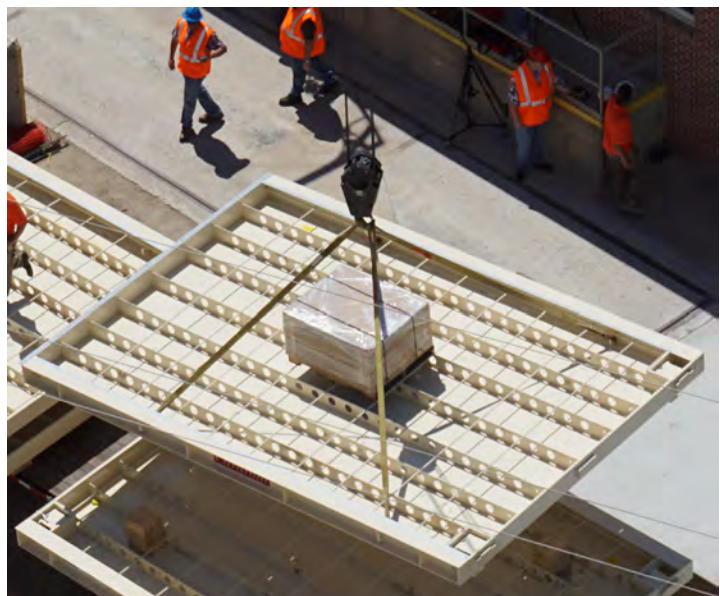

Optional Lifting Lugs on Steel Decks

Lifting lugs are available for steel deck scales for the lifting of scale modules by attaching straps, cables, or chains.

Note that the lifting lugs are shipped on the last module loaded on the truck at the factory.



Optional bolt-on lifting lugs are available for lifting steel deck scale modules.



Modifications at the factory to the steel deck are required to attach lifting lugs. Lifting lugs cannot be used on an unmodified steel deck. If it is desired to use lifting lugs, the scale order must clearly state that lifting lugs are to be used and the lifting lugs ordered with the scale.

Load Cells and Load Cell Stands

The load cells and load cell stands on **standard** models are shipped installed and held in place with shipping brackets.



IMPORTANT! Do not remove the shipping brackets until the load cell stands are securely bolted to the foundation.



WARNING! Permanent damage may occur if the truck scale is not properly installed.

Establish the centerline of the piers. Snap a longitudinal chalk line off the centerline and a lateral chalk line from the edge of the end piers, per the foundation drawing. To aid in aligning the bridges, run a string down the side of the foundation.

1. Place wood blocks on the piers as safety blocks for setting the modules on.



NEVER place the weighbridge modules directly on the piers with a crane, as damage to the load cells may result.

2. Set the first weighbridge module on the wood blocks so the module ends are on the end pier chalk lines and the edge of the module lines up with the longitudinal chalk line or string.



Set weighbridge module on wood blocks aligning with chalk lines or string.
NOTE: Shown with optional bolt-on lifting lugs.



Weighbridge module ends should be plumb on end pier chalk lines and the lower edge of the weighbridge module should align with longitudinal chalk line or string.

NOTE: Shown with optional bolt-on lifting lugs.

3. After the weighbridge module is on the blocks and aligned, use a hydraulic jack to lift the weighbridge module and remove the wood blocks.
4. Carefully lower the weighbridge module on the pier and verify the load cell stand is level on the pier.
5. Repeat this procedure at all load cell stands on the weighbridge module.

- Using the alignment bolts, position the first module so that there is one-inch clearance from the edge of the module to the coping angle assembly.



NOTE: Alignment bolts are used for scale installation only and must be removed before scale calibration and operation.



One-inch clearance is required from edge of the module to coping angle assembly.



The alignment bolts must be removed before scale calibration and operation.

- On a steel deck installation with the optional lifting lugs, remove them from the first bridge module and install them on the second bridge module. Attach the straps, cables, or chains to the lifting lugs. Otherwise, attach the straps, cables, or chains to the side rail mounts.
- Lower the second bridge module onto the wood blocks on the load cell end. When in position, align the receiver cup on it with the support block on the first bridge module.



Lower second bridge onto wood blocks and support blocks of the first bridge.



Align the second bridge receiver cups with the first bridge support blocks.

- After the weighbridge module is aligned and connected to the first module, use the hydraulic jack to lift the weighbridge and remove the wood blocks.
- Carefully lower the weighbridge on the pier and verify the load cell stand is level on the pier.
- Repeat this procedure for the remaining load cell stand.



Second bridge receiver cup aligned with the first bridge support block.

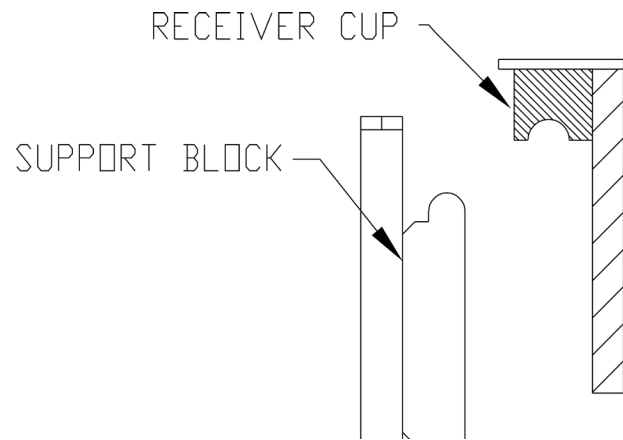

Bridge Connection Detail

12. For each additional bridge module on a steel deck installation with the optional lifting lugs, remove them from the previous module and install them on the next module. Attach the straps, cables, or chains to the lifting lugs. Otherwise, attach the straps, cables, or chains to the side rail mounts.
13. Lower the additional bridge module onto the wood blocks on the load cell end. When in position, align the receiver cup on it with the support block on the previous bridge module.
14. After the weighbridge module is aligned and connected to the previous module, use the hydraulic jack to lift the weighbridge and remove the wood blocks.
15. Carefully lower the weighbridge on the pier and verify the load cell stand is level on the pier.
16. Repeat this procedure for the remaining load cell stand.

Bridge Module Installation with Separately Shipped Load Cell Stands

In installations where the load cell stands are very tall or for other reasons the bridge modules are shipped without the load cell stands installed at the factory, the following procedure will guide you through the installation of the load cell stands to the weighbridge and installation of the weighbridge modules.

Lifting Steel Decks

Steel deck scale modules can be lifted by attaching straps, cables, or chains to the guide rail brackets on the module. Note that the hook-on and hook-end bridges have an additional guide rail bracket (*with 1-inch diameter holes*) that can be used for the sole purpose of being a lifting bracket. When being lifted by a crane, the additional brackets can be used to facilitate an equal balance of the bridge. The additional lifting brackets are on the opposite end from where the load cell stands would be installed in hook-on and hook-end bridges and are located just inside the outer guide rail bracket.

Because the end bridges are already balanced equally from end-to-end with or without the load cell stands installed, they don't have the additional lifting bracket. They should be lifted using the guide rail brackets on the module.



Hook-on and hook-end bridges have an additional guide rail bracket that can be used when lifting by a crane.



When being lifted by a crane, the additional brackets can be used to facilitate an equal balance of the bridge.

Lifting Concrete Decks

Concrete deck scales have lifting lugs integral to all modules. They can be lifted by attaching straps, cables, or chains to the lifting lugs built into the frame. Refer to the Final Assembly Drawing.

Modules for concrete scale decks have lifting lugs built into the frame.



Optional Lifting Lugs on Steel Decks

Lifting lugs are available for steel deck scales for the lifting of scale modules by attaching straps, cables, or chains.

Note that the lifting lugs are shipped on the last module loaded on the truck at the factory.

Optional bolt-on lifting lugs are available for lifting steel deck scale modules.



Modifications at the factory to the steel deck are required to attach lifting lugs. Lifting lugs cannot be used on an unmodified steel deck. If it is desired to use lifting lugs, the scale order must clearly state that lifting lugs are to be used and the lifting lugs ordered with the scale.

1. Referring to the foundation drawing, establish the centerline of the piers. Snap a longitudinal chalk line off the centerline and a lateral chalk line from the edge of the end piers, per the foundation drawing.
2. To aid in aligning the placement of bridges, run a string down the side of the foundation.



Snap a longitudinal chalk line on edge of piers per foundation drawing.

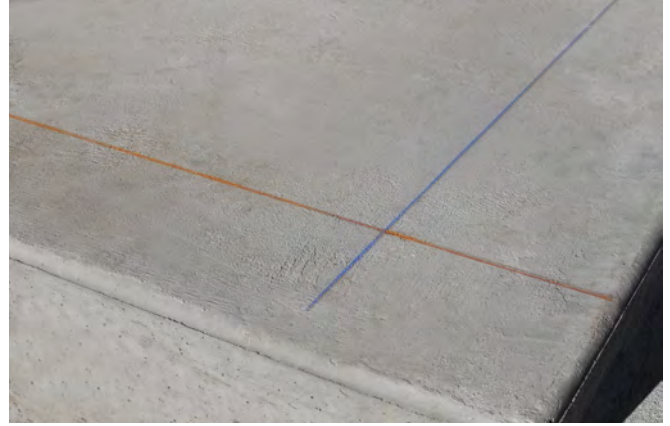

Per foundation drawing, snap a lateral chalk line for aligning load cell stands.

3. Referring to the foundation drawing, place **all** load cell stands on the foundation piers.

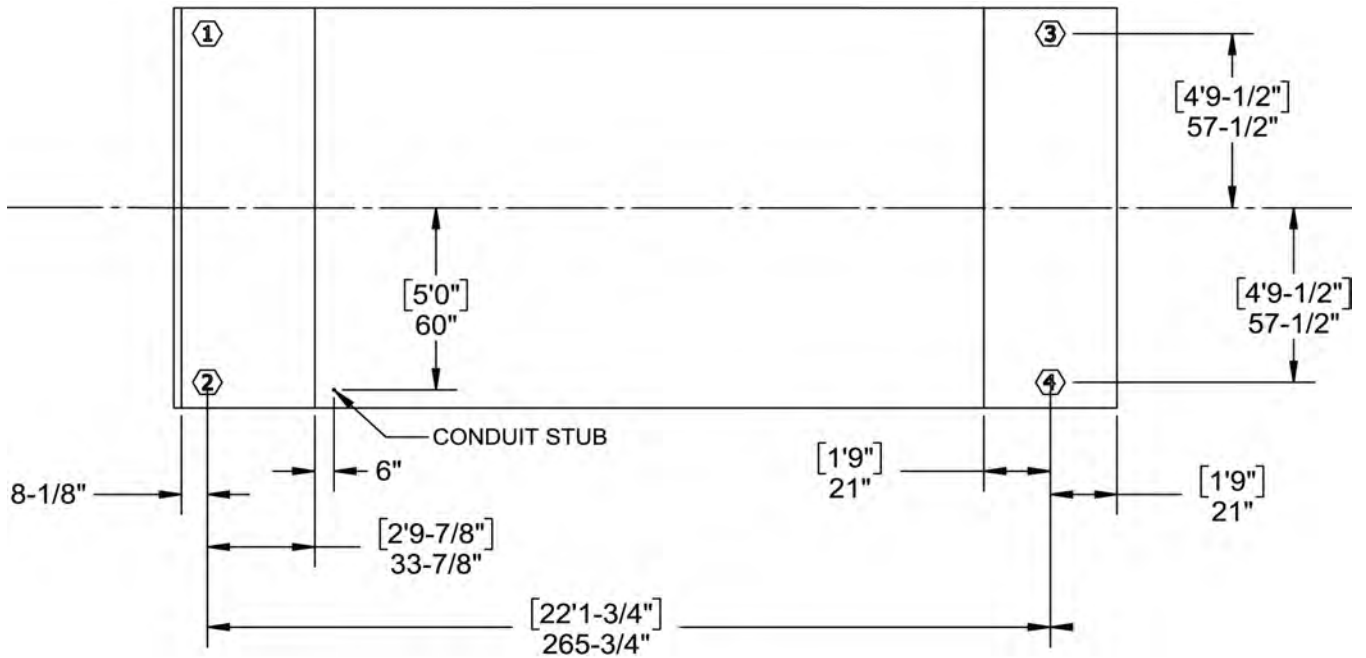

NOTE: Dimensions shown are for one section of a standard 70' x 11' scale.

***** FOR REFERENCE ONLY *****

4. Referring to the illustration below, place the Bearing Cup Receiver into the indentation of the Lower Receiver Bearing Cup (circular part of the Load Cell Stand).
5. Next, place the Ball Bearing into the Bearing Cup Receiver.
6. Repeat steps 4 and 5 for **all** load cell stands.
7. Place wood blocks on the piers to set the weighbridge modules on.

NOTE: It is recommended that the wood blocks are approximately the height of the load cell stands to allow space between the load cell (which is already mounted in the weighbridge) and the stand components. The space will aid in centering the stand under the load cell when lowering the weighbridges in place.

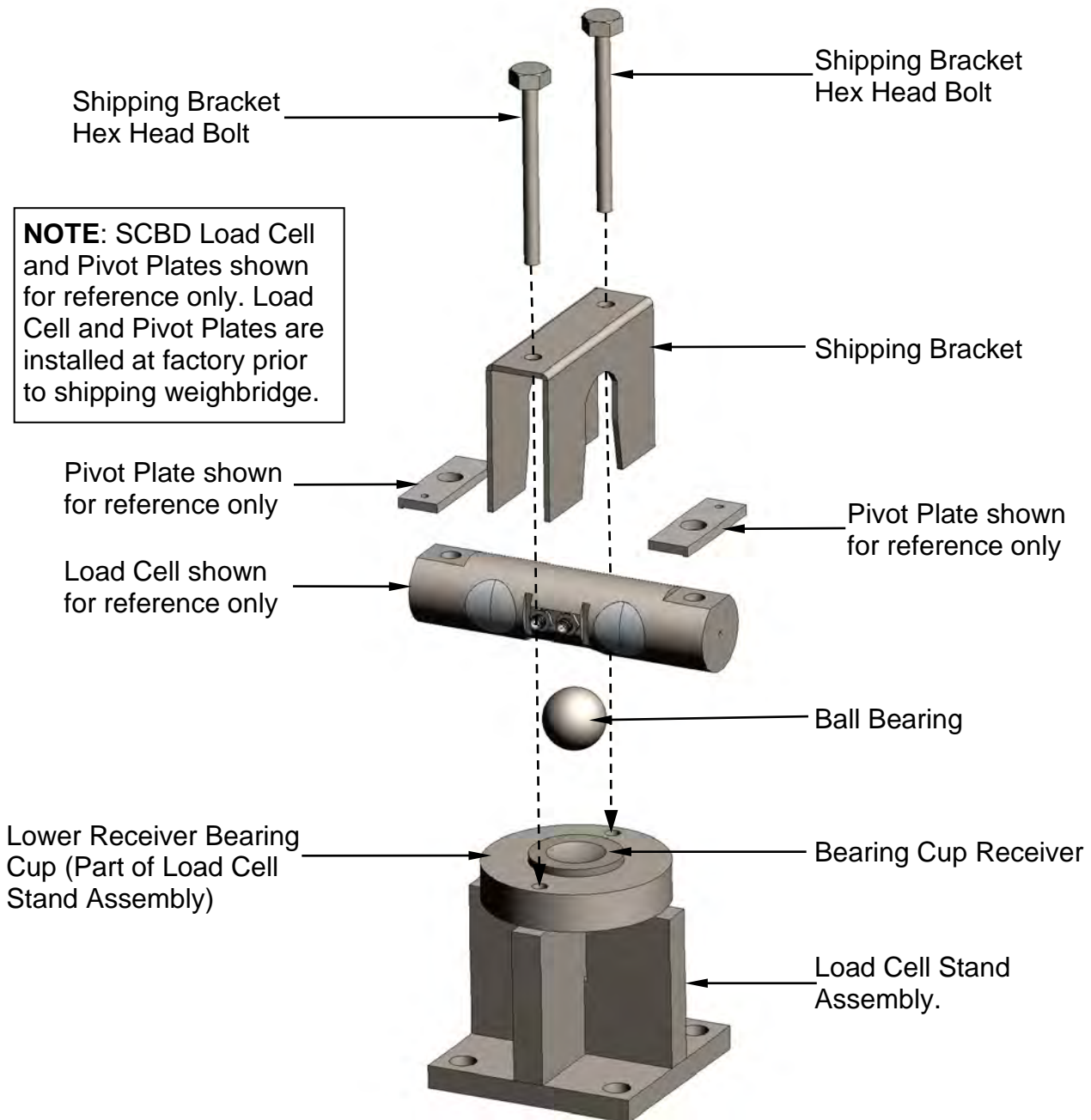

8. Set the first weighbridge module on the wood blocks so the module ends are on the pier chalk lines and the edge of the module lines up with the string on the side of the foundation.



Set the weighbridge on the wood blocks aligning with string ran down the side of the foundation. NOTE: Shown with optional bolt-on lifting lugs.

9. After the weighbridge module is on blocks and aligned, use a hydraulic jack to lift the weighbridge module and remove the wood blocks.
10. Referring to the illustration on the previous page, place the Shipping Bracket over the SCBD load cell, and then insert the two Shipping Bracket Hex Head Bolts into the Shipping Bracket, and align them with the holes in the Lower Receiver Bearing Cup (circular part of the Load Cell Stand).
11. Carefully lower the weighbridge module onto the load cell stand, making sure the Ball Bearing, Bearing Cup Receiver, and Load Cell Stand are centered under the load cell.
12. Tighten the shipping bracket bolts, and torque to 50 ft-lbs.
13. Repeat steps 9 through 11 for all load cell stands on the weighbridge module.
14. Using the alignment bolts, position the first module so that there is one-inch clearance from the edge of the module to the coping angle assembly.



NOTE: Alignment bolts are used for scale installation only and must be removed before scale calibration and operation.



One-inch clearance is required from the edge of module to coping angle assembly.

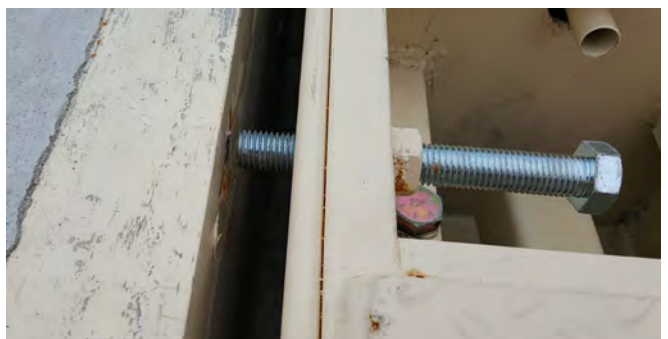

The alignment bolts must be removed before scale calibration and operation.

15. On a steel deck installation with the optional lifting lugs, remove them from the first bridge module and install them on the second bridge module. Attach the straps, cables, or chains to the lifting lugs. Otherwise, attach the straps, cables, or chains to the guide rail bracket.
16. Lower the second bridge module onto the wood blocks on the load cell end. When in position, align the receiver cup on it with the support block on the first bridge module.



Remove the lifting lugs from the first bridge and install them on the second.

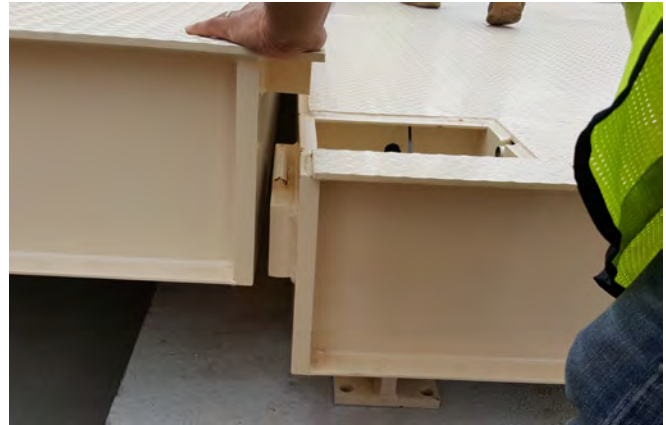

Align the second bridge receiver cup with the first bridge support block.



Second bridge receiver cup aligned with the first bridge support block.

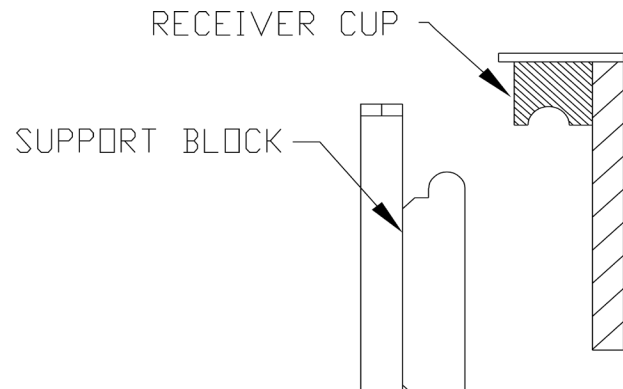

Bridge Connection Detail

17. After the weighbridge module is aligned and connected to the first module, use the hydraulic jack to lift the weighbridge and remove the wood blocks.
18. Repeat steps 9 through 11 for all load cell stands on the second weighbridge module.
19. For each additional bridge module on a steel deck installation with the optional lifting lugs, remove them from the previous module and install them on the next module. Attach the straps, cables, or chains to the lifting lugs. Otherwise, attach the straps, cables, or chains to the guide rail bracket.
20. Lower the additional bridge module onto the wood blocks on the load cell end. When in position, align the receiver cup on it with the support block on the previous bridge module.
21. After the weighbridge module is aligned and connected to the previous module, use the hydraulic jack to lift the weighbridge and remove the wood blocks.
22. Repeat steps 9 through 11 for all load cell stands on each additional module.

Install Load Cell Stand Anchor Bolts

1. Remove the cable tray.

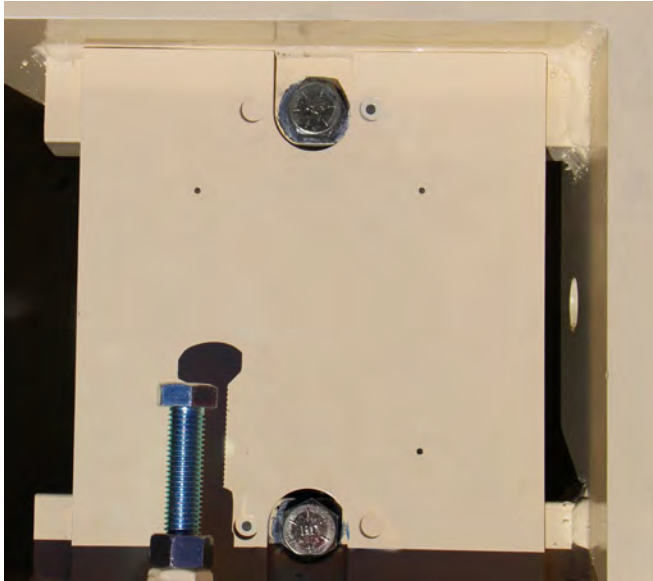

Remove the cable tray.

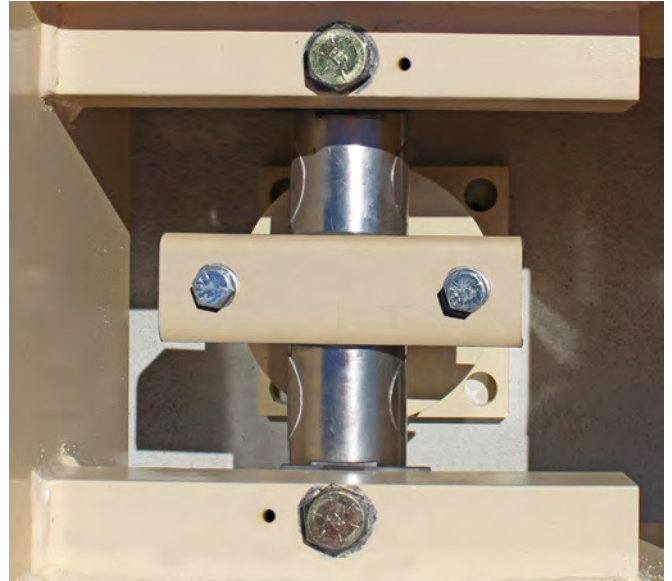

With the cable tray removed, the shipping bracket and load cell stands are visible.

2. Ensure the load cell stand is completely against the concrete pier. If required, tap on the stand to level it against the pier before drilling anchor holes.
3. Drill four 3/4-inch diameter holes for the anchor bolts. Holes should be 10 inches deep for supplied anchor bolts. To allow the drill to clear the shipping bracket and drill the anchor bolt holes 10 inches deep, a 36-inch drill bit is required.



A 36-inch drill bit is required to clear the access opening when drilling the holes.



Drill 3/4-inch diameter holes 10 inches deep to install the anchor bolts.



IMPORTANT! To ensure the anchor bolt holes are at the correct depth, remove the dust from the holes after drilling is complete. Use a vacuum (with a long nozzle) to vacuum the dust out of the holes.

4. Insert the anchor bolts, and then using a 1 1/8-inch socket and impact wrench, tighten the anchor bolts.

NOTE: The anchor bolts are self-threading and must be installed with an impact wrench to secure the load cell stand to the pier. Note that the impact wrench used to install the anchor bolts must have a torque rating between 3000 (min.) to 4000 (max.) inch-pounds.



Insert anchor bolts and use a 1 1/8-inch socket and impact wrench to tighten.



The impact wrench used to install anchor bolts must have a 3000 to 4000 in-lb torque rating.

Concrete Scale Deck Specifications and Installation (SPEC. #0104-A020-ES)

This specification shall consist of furnishing, placing, finishing, and curing concrete on Cardinal's Digital Truck Scale.

1. Concrete Specifications

- A. Class A (AE) concrete shall be used on all scale decks.
- B. The concrete is to have a 6.5 bag mix with a minimum of 1.5 pounds per cubic yard of 0.75-inch-long polypropylene fiber and compression strength of 4500 PSI.
- C. The range of slump shall not exceed 3.5 inches and shall be determined in accordance with AASHTO-T119.
- D. Samples for strength test shall be taken to certify the class of concrete used (record results of strength test).

2. Placing of Concrete

- A. The temperature of the concrete mixture immediately before placement shall be between 50°F and 90°F.
- B. When the ambient temperature is above 90°F the forms, steel beam flanges, and other surfaces that will come in contact with the mix, shall be cooled to below 90°F by means of water spray or other approved methods.
- C. No concrete shall be placed when the air temperature is below 35°F or when forecasts indicate air temperatures below 32°F during the succeeding five days.
- D. Support midpoint of decks until the concrete is cured.



NOTE: Shore weighbridges continuously laterally across weighbridge at mid-span (L2). The entire weighbridge frame must be within 1/4 inch of the same horizontal plane.

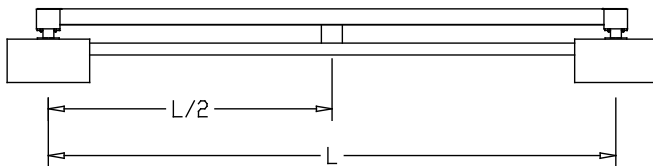
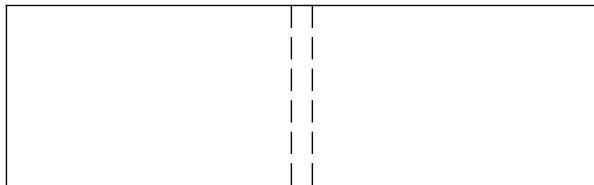

Shoring Weighbridges

Tape the edges of the bridge modules prior to pouring the concrete to maintain a clean scale edge afterward.



3. Finishing Concrete Decks

A. After the concrete has been placed and vibrated, the deck shall be struck off with a screed.



Placing the concrete.



After the concrete has been placed, it should be vibrated.

B. The screed must have sufficient strength to retain its shape and be of sufficient length to span the lateral width of the deck.

C. During the screeding operation, an adequate supply of concrete shall be kept ahead of the screed and a slight excess shall be maintained immediately in front of the screed.



The screed must retain shape and span the lateral width of the deck.



Keep a supply of concrete ahead of screed during screeding operation.

D. The contractor shall have available, on the site, fogging equipment that shall be capable of applying water to the concrete in the form of a fine fog mist in sufficient quantity to curb the effects of rapid evaporation of mixing water.

- E. After the concrete has been consolidated and struck off and before the concrete becomes non-plastic, the surface of the deck shall be further finished to provide a uniform surface texture.
- F. Following the finishing and before the concrete becomes non-plastic, the surface shall then receive a transverse texture produced by a wire broom (broom strokes perpendicular to the direction of traffic).



Before concrete becomes non-plastic, deck surface should be further finished to provide a uniform surface texture.



Apply a transverse texture to concrete with a wire broom (broom strokes perpendicular to the direction of traffic).

4. Curing Concrete Decks

- A. Special curing considerations must be taken when placing concrete in ambient temperatures above 90°F and/or temperatures below 35°F.
- B. A curing day will be considered as any consecutive 24-hour period from the time of concrete placement.
- C. Immediately after finishing, the deck shall be covered with wet cotton mats or two thicknesses of wet burlap blankets.



IMPORTANT! The cotton mats or burlap blankets shall be kept continuously and thoroughly wet during the curing period (a minimum of seven days).

- 5. There shall be NO LOAD placed on the decks for a minimum of 28 days.
- 6. The contractor/owner is responsible for furnishing, placing, finishing, and curing concrete decks as outlined above. Deviation from the above specifications shall be at the contractor's own risk.

HOMERUN CABLE INSTALLATION

Homerun Cable Installation

The Homerun Cable is made from five conductors, shielded PVC cable. The main (longer) section is connected to the SCALE terminal block in the POWER-DLC, and the load cell end is terminated with a 5-pin actuation lever-type connector from the Home Run Cable Connector Pack. An additional (shorter) section of Homerun Cable is connected to the INDICATOR terminal block in the POWER-DLC and the DLC card in the 225D or 825D indicator. Refer to the table below for cable and connector information.

Cable and Connector Information

ITEM and DESCRIPTION	CARDINAL PART NO.
HOMERUN CABLE, 5 CONDUCTORS, SHIELDED PVC (CONTAINS 2 x 18AWG, 2 x 22AWG, AND 1 x 22AWG)	6980-1092
BAGGED CONNECTOR AND INSTRUCTION SHEET (INCLUDES 5-PIN ACTUATION LEVER-TYPE CONNECTOR, 6610-1308)	3502-0681-0A

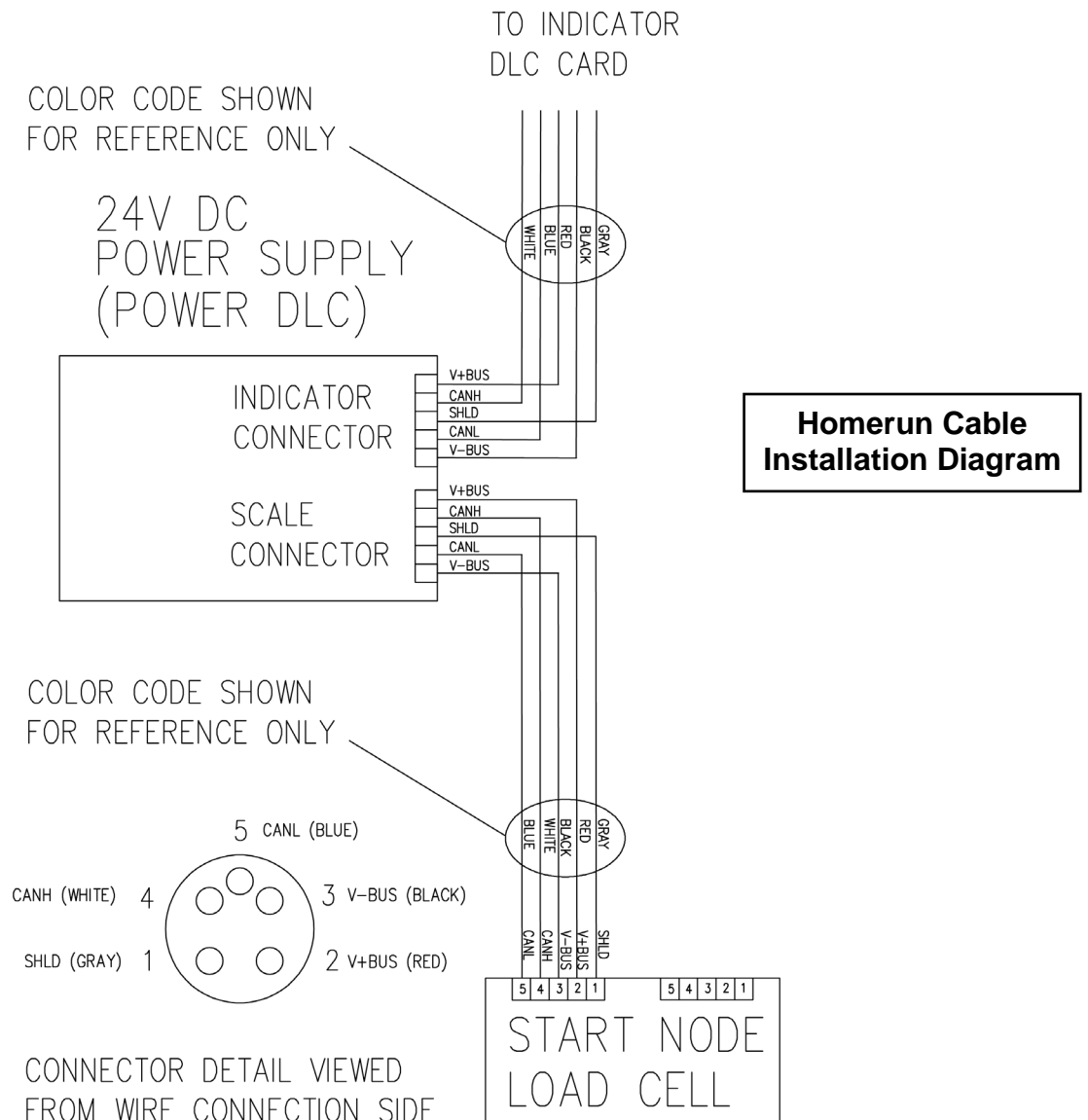

The main (longer) section of the Homerun Cable is connected to the first load cell in the loop (the Start Node) and the SCALE terminal block in POWER-DLC. An additional (shorter) section of Homerun Cable is then connected to the INDICATOR terminal block in the POWER-DLC and the indicator DLC card.

 **IMPORTANT! MAKE SURE THE ICAN JUMPERS, J2 AND J3 ON THE 225-DLC CARD (J1 AND J3 ON THE 825-DLC CARD) ARE REMOVED BEFORE APPLYING POWER!**

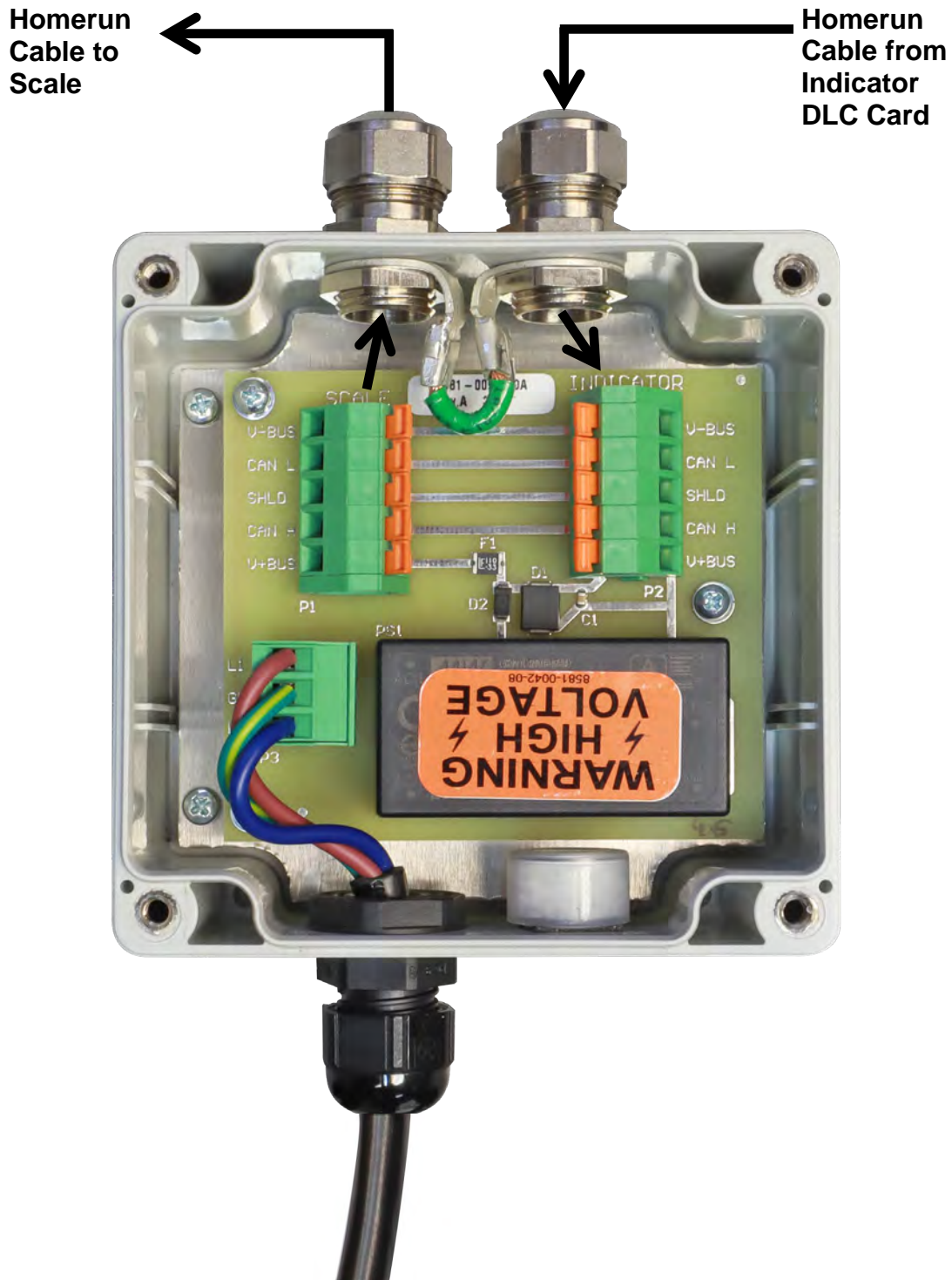

Power-DLC to Scale Connection

To suppress noise, the homerun cable to the scale should be routed through the special metallic gland connector in the POWER-DLC and the cable shield from the homerun cable connected to the metal gland connector for grounding. Refer to the image on page 28 for the POWER-DLC gland connector layout.

1. Remove the four screws securing the cover of the POWER-DLC.

2. Loosen and remove the metal gland connector nut, then remove the plastic insert.

3. Slip the homerun cable to the scale through the nut and plastic insert.

4. Remove approximately 3.0 inches (76 mm) of the homerun cable outer jacket, exposing the cable shield and internal wires.

5. Cut the cable shield so it extends past the outer jacket approximately 3/4 inches (19 mm).

6. Next, remove approximately 1/4 inch (6 mm) of the insulation from each of the five wires.

7. Slide the plastic insert up the cable and fold the cable shield back over the plastic insert.

8. Insert the plastic insert (with the cable shield) into the metal gland connector for the scale. The cable shield will be secured when tightening the gland connector nut.

9. Make sure the gland connector nut is tight, but do not over-tighten it.

10. With the homerun cable to the scale routed into the POWER-DLC, refer to the table below (or the circuit board) for terminal connections, and connect each wire to the SCALE terminal block on the POWER-DLC board.

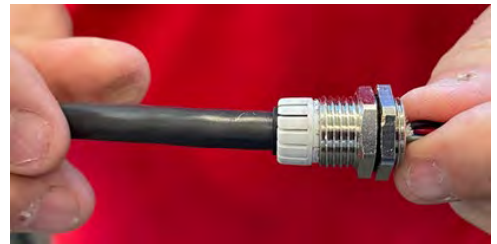

POWER-DLC SCALE Connector Terminal Connections

Board Label	Homerun Cable Wire Color	Wire Color if using a Load Cell Cable
SHLD	GRAY	BROWN
V+BUS	RED	WHITE
V-BUS	BLACK	BLUE
CAN H	WHITE	BLACK
CAN L	BLUE or LIGHT BLUE	GRAY

11. Using a small flat blade screwdriver press down on the release bar for the terminal, insert the wire into the opening, and then remove the screwdriver. The release bar will return to its original position, locking the wire in place.

12. Repeat steps 10 and 11 until all five wires of the homerun cable to the scale are installed in the SCALE terminal block on the POWER-DLC board.

Power-DLC to Indicator DLC Card Connection

To suppress noise, the homerun cable from the indicator DLC card should be routed through the special metallic gland connectors in the POWER-DLC and the cable shield from the cable connected to the metal gland connector for grounding. Refer to the image on page 28 for the POWER-DLC gland connector layout and the images on page 29 for installing the homerun cable shield in the gland connector.

1. With the cover, off from the previous operation, loosen and remove the metal gland connector nut, then remove the plastic insert.
2. Slip the homerun cable from the DLC card through the nut and plastic insert.
3. Remove approximately 3.0 inches (76 mm) of the homerun cable outer jacket, exposing the cable shield and internal wires.
4. Cut the cable shield so it extends past the outer jacket approximately 3/4 inches (19 mm).
5. Next, remove approximately 1/4 inch (6 mm) of the insulation from each of the five wires.
6. Slide the plastic insert up the cable and fold the cable shield back over the plastic insert.
7. Insert the plastic insert (with the cable shield) into the metal gland connector for the indicator. The cable shield will be secured when tightening the gland connector nut.
8. Make sure the gland connector nut is tight, but do not over-tighten it.
9. With the homerun cable from the DLC card routed into the POWER-DLC, refer to the table below (or the circuit board) for terminal connections, and connect each wire to the INDICATOR terminal block on the POWER-DLC board.

POWER-DLC TERMINAL Connector Terminal Connections

Board Label	Homerun Cable Wire Color	Wire Color if using a Load Cell Cable
SHLD	GRAY	BROWN
V+BUS	RED	WHITE
V-BUS	BLACK	BLUE
CAN H	WHITE	BLACK
CAN L	BLUE or LIGHT BLUE	GRAY

10. Using a small flat blade screwdriver press down on the release bar for the terminal, insert the wire into the opening, and then remove the screwdriver. The release bar will return to its original position, locking the wire in place.
11. Repeat steps 9 and 10 until all five wires of the homerun cable to the scale are installed in the SCALE terminal block on the POWER-DLC board.

Re-Installing the POWER-DLC Cover

1. After all connections to the SCALE and INDICATOR terminal blocks have been made, secure the POWER-DLC cover with the four screws removed earlier, following a diagonal pattern when tightening the screws.
2. Using a torque wrench, tighten the metal gland connectors to 33 in-lb (3.7 Nm).

POWER-DLC to 225D Indicator Connection

To suppress noise, the (shorter section) of the homerun cable from the INDICATOR terminal block in the POWER-DLC, should be routed through the metallic gland connector installed in the lower right of the 225D rear panel and the cable shield from the cable connected to the metal gland connector for grounding. Refer to the image below for the gland connector layout and the images on page 29 for installing the homerun cable shield in the gland connector.

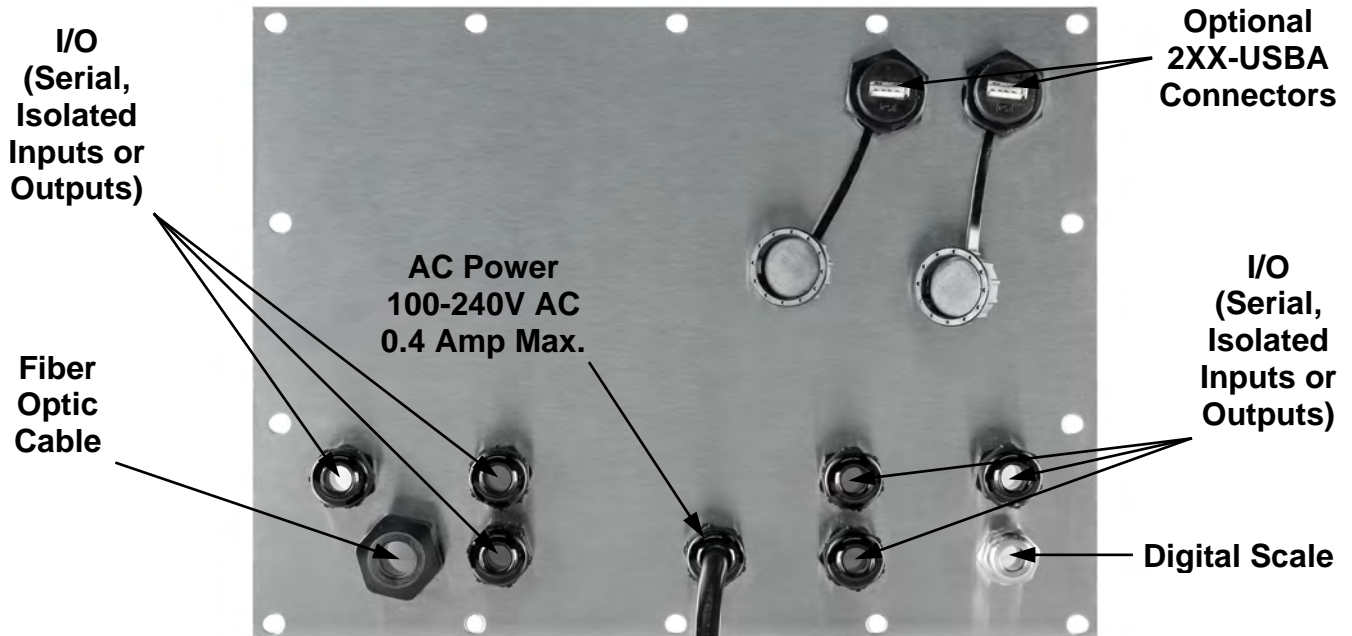



ATTENTION!
OBSERVE PRECAUTIONS FOR HANDLING
ELECTROSTATIC SENSITIVE DEVICES

1. Remove the fourteen acorn nuts securing the rear panel assembly to the main housing.
2. Lift the rear panel from the main housing, taking care not to stretch the cable and wires between the panel and main housing. Lay the panel on the workbench next to the indicator.



IMPORTANT: You may need to loosen the gland connectors for the I/O cables to allow enough slack in the cable and wires to avoid stretching them.

3. Loosen and remove the metal gland connector nut, then remove the plastic insert.
4. Slip the homerun cable from the INDICATOR terminal block in the POWER-DLC through the nut and plastic insert.
5. Remove approximately 6.0 inches (15 cm) of the homerun cable outer jacket, exposing the cable shield and internal wires.
6. Cut the cable shield so it extends past the outer jacket approximately 3/4 inches (19 mm).

7. Next, remove approximately 1/4 inch (6 mm) of the insulation from each of the five wires.
8. Slide the plastic insert up the cable and fold the cable shield back over the plastic insert.
9. Insert the plastic insert (with the cable shield) into the metal gland connector on the 225D rear panel. The cable shield will be secured when tightening the gland connector nut.
10. Make sure the gland connector nut is tight, but do not over-tighten it.
11. Referring to the table below (or the circuit board) for terminal connections, connect each wire of the homerun cable from the POWER-DLC to the P5 terminal block on the 225DLC controller card.

225DLC Controller Card P5 Terminal Connections

Board Label	Homerun Cable Wire Color	Wire Color if using a Load Cell Cable
SHLD	GRAY	BROWN
V+BUS	RED	WHITE
V-BUS	BLACK	BLUE
CAN H	WHITE	BLACK
CAN L	BLUE or LIGHT BLUE	GRAY

12. Using a small flat blade screwdriver press down on the release bar for the terminal, insert the wire into the opening, and then remove the screwdriver. The release bar will return to its original position, locking the wire in place.

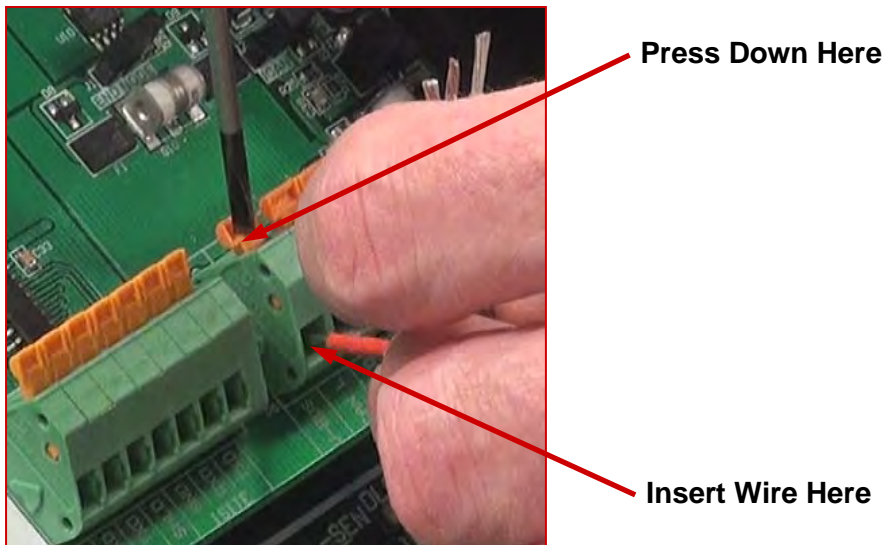

13. Repeat steps 11 and 12 until all five wires of the homerun cable are installed in the P5 terminal block on the 225DLC controller card.
14. Referring to the illustration on the next page, remove the ICAN jumpers J2 and J3.

225DLC Card ICAN Jumpers

The ICAN jumpers (J2 and J3) must be OFF (on one pin only or removed) when using the POWER-DLC to power to the digital load cells in the scale. **NOTE:** If these jumpers are ON (installed), the 225D indicator is supplying the power to the digital load cells in the scale, and the POWER-DLC **cannot** be used.



IMPORTANT! Jumpers J2 and J3 must be OFF (on one pin only or removed) when the POWER-DLC is used to power the digital load cells in the scale.

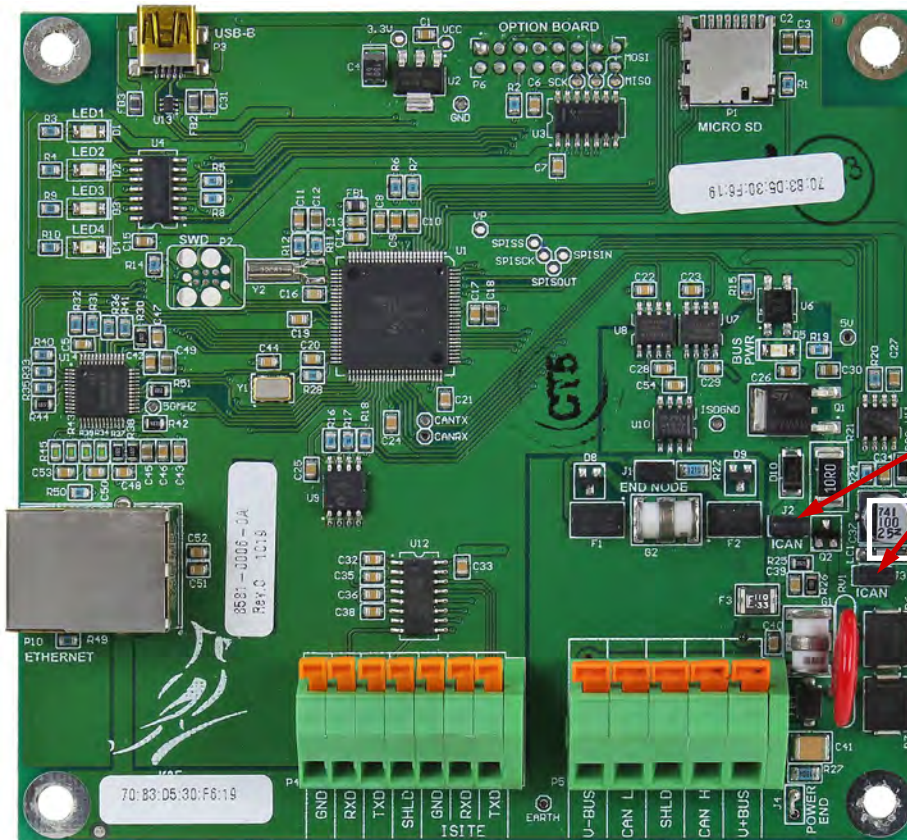

Remove J2, J3
ICAN Jumpers
when using
POWER-DLC

Re-installing the 225D Rear Panel

1. After all terminations have been made and the ICAN jumpers J2 and J3 have been removed, remove the excess cable from any other cables from the indicator enclosure, and finger-tighten each of the cable gland connectors.
2. Ensure any unused gland connectors are plugged and replace the rear panel.
3. Secure the rear panel with the fourteen acorn nuts removed earlier, following a diagonal pattern when tightening the acorn nuts.
4. Using a torque wrench, tighten the plastic gland connectors to 15 in-lb (1.7 Nm).
5. Using a torque wrench, tighten the metal gland connector to 33 in-lb (3.7 Nm).

POWER-DLC to 825D Indicator Connection

To suppress noise, the (shorter section) of the homerun cable from the INDICATOR terminal block in the POWER-DLC, should be routed through the metallic gland connector installed in the bottom panel of the 825D and the cable shield from the cable connected to the metal gland connector for grounding. Refer to the image below for the gland connector layout and the images on page 29 for installing the homerun cable shield in the gland connector.

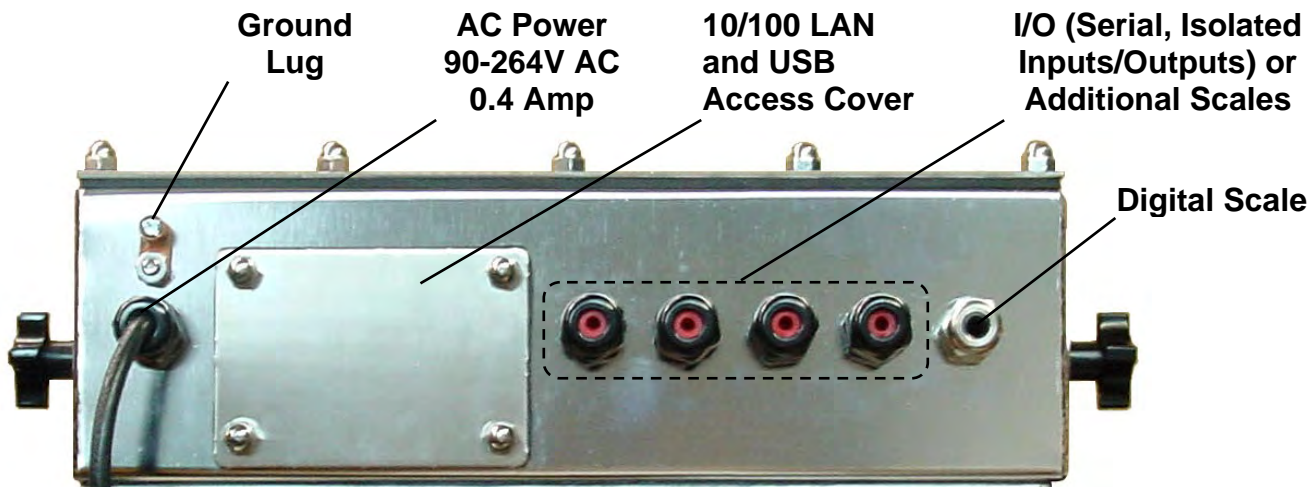

1. Remove the fourteen acorn nuts securing the rear panel assembly to the main housing.
2. Lift the rear panel from the main housing, taking care not to stretch the cable and wires between the panel and main housing. Lay the rear panel on the workbench next to the indicator.



IMPORTANT: You may need to loosen the gland connectors for the I/O cables to allow enough slack in the cable and wires to avoid stretching them.

3. Loosen and remove the metal gland connector nut, then remove the plastic insert.
4. Slip the homerun cable from the INDICATOR terminal block in the POWER-DLC through the nut and plastic insert.
5. Remove approximately 6.0 inches (15 cm) of the homerun cable outer jacket, exposing the cable shield and internal wires.
6. Cut the cable shield so it extends past the outer jacket approximately 3/4 inches (19 mm).
7. Next, remove approximately 1/4 inch (6 mm) of the insulation from each of the five wires.

8. Slide the plastic insert up the cable and fold the cable shield back over the plastic insert.
9. Insert the plastic insert (with the cable shield) into the metal gland connector on the bottom of the 825D. The cable shield will be secured when tightening the gland connector nut.
10. Make sure the gland connector nut is tight, but do not over-tighten it.
11. Remove the screw securing the 825-DLC card to the 825D main PC board and then lift the 825-DLC card straight up to remove it from the enclosure
12. Referring to the table below (or the circuit board) for terminal connections, connect each wire of the homerun cable from the POWER-DLC to the P1 terminal block on the 825-DLC controller card.

825DLC Controller Card P1 Terminal Connections

Board Label	Homerun Cable Wire Color	Wire Color if using a Load Cell Cable
SHLD	GRAY	BROWN
V+BUS	RED	WHITE
V-BUS	BLACK	BLUE
CAN H	WHITE	BLACK
CAN L	BLUE or LIGHT BLUE	GRAY

13. Using a small flat blade screwdriver press down on the release bar for the terminal, insert the wire into the opening, and then remove the screwdriver. The release bar will return to its original position, locking the wire in place.
14. Repeat steps 12 and 13 until all five wires of the homerun cable are installed in the P1 terminal block on the 825DLC controller card.
15. Referring to the illustration on the next page, remove the ICAN jumpers J1 and J3.
16. After all terminations have been made and the ICAN jumpers J1 and J3 have been removed, reinstall the 825-DLC into the enclosure, taking care not to strike the board against the side of the 825D enclosure.
17. Secure the 825-DLC to the main PC board with the screw removed earlier.

825-DLC Card ICAN Jumpers

The ICAN jumpers (J1, J3) must be OFF (on one pin only or removed) when using the POWER-DLC to power to the digital load cells in the scale. **NOTE:** If these jumpers are ON (installed), the 825D indicator is supplying the power to the digital load cells in the scale, and the POWER-DLC *cannot* be used.



IMPORTANT! Jumpers J1 and J3 must be OFF (on one pin only or removed) when the POWER-DLC is used to power the digital load cells in the scale.

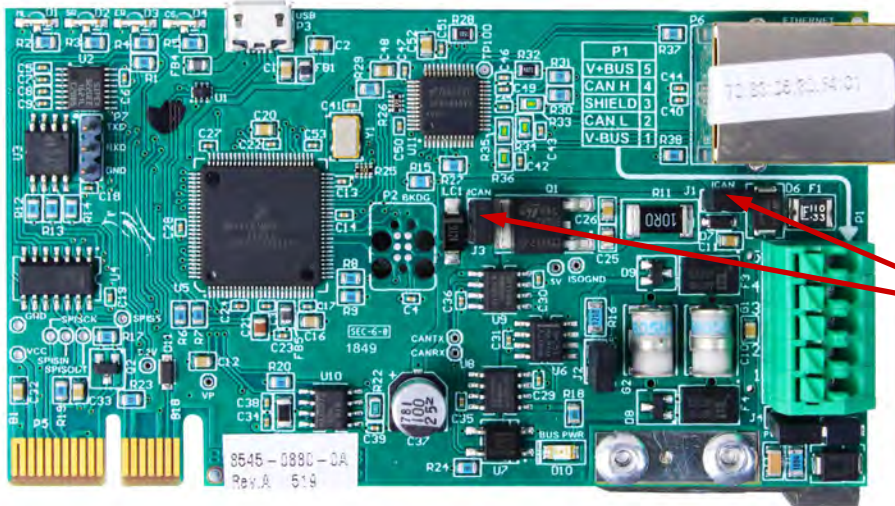

**Remove J1, J3
ICAN Jumpers
when using
POWER-DLC**

Re-installing the 825D Rear Panel

1. After all terminations have been made, and the 825-DLC is secured to the main PC board, remove the excess cable from any other cables from the indicator enclosure, and finger-tighten each of the cable gland connectors.
2. Ensure any unused gland connectors are plugged and replace the rear panel.
3. Secure the rear panel with the fourteen acorn nuts removed earlier, following a diagonal pattern when tightening the acorn nuts.
4. Using a torque wrench, tighten the plastic gland connectors to 15 in-lb (1.7 Nm).
5. Using a torque wrench, tighten the metal gland connector to 33 in-lb (3.7 Nm).

Load Cell to POWER-DLC Connection

The main (longer section) of the Homerun Cable is installed between the first load cell in the loop (Start Node) and the SCALE terminal block of the POWER-DLC. It is made from five conductors, shielded PVC cable, and terminated with the *included* 5-pin actuation lever-type connector from the Homerun Cable Connector Pack. Refer to the table below for cable and connector information.

Cable and Connector Information

ITEM and DESCRIPTION	CARDINAL PART NO.
HOMERUN CABLE, 5 CONDUCTORS, SHIELDED PVC (CONTAINS 2 x 18AWG, 2 x 22AWG, AND 1 x 22AWG)	6980-1092
BAGGED CONNECTOR AND INSTRUCTION SHEET (INCLUDES 5-PIN ACTUATION LEVER-TYPE CONNECTOR, 6610-1308)	3502-0681-0A



IMPORTANT: Clean the load cell connectors and the homerun connector plug with electrical contact cleaner, and then apply dielectric grease to the homerun connector plug before installing it into the load cell connector.

1. Dis-assemble the connector (unscrew the black plastic part of the connector from the metal part), and then slide the black plastic part onto the homerun cable.

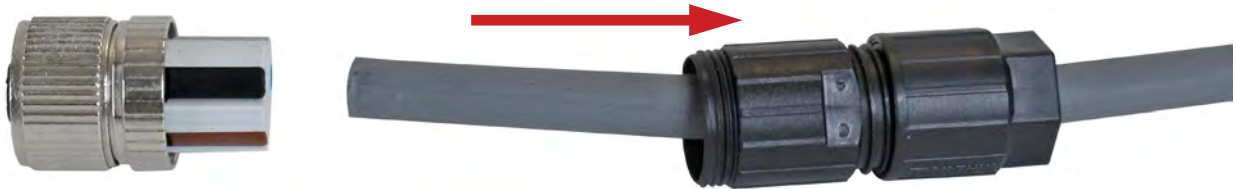

2. With the homerun cable routed through the black plastic part of the connector, remove approximately 1 inch (25 mm) of the cable's outer jacket, exposing the internal wires.
3. Next, remove approximately 5/16 inches (8 mm) of insulation from each of the five wires.



NOTE: The hex part of the black plastic cable clamp is approximately 5/16 inches (8 mm) and can be used as a guide for stripping the wires.

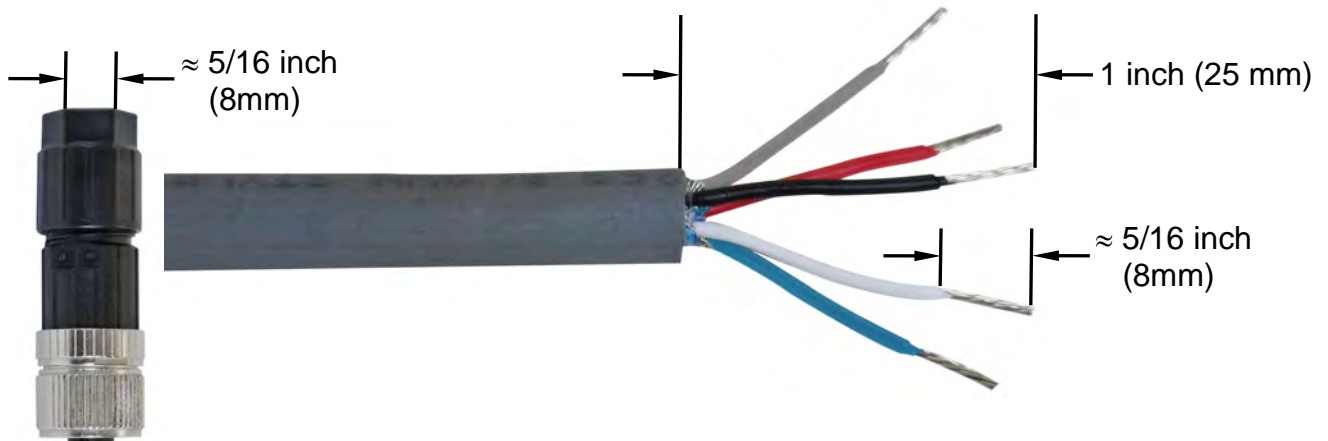



Refer to the Homerun Connector Wiring Color Code Table below when performing steps 4 through 7.

Homerun Connector Wiring Color Code Table

Pin Number	Connector Lever Color	Signal	Homerun Cable Wire Color	Wire Color if using a Load Cell Cable
1	BROWN	SHLD	GRAY	BROWN
2	WHITE	V+BUS	RED	WHITE
3	BLUE	V-BUS	BLACK	BLUE
4	BLACK	CAN H	WHITE	BLACK
5	GRAY	CAN L	BLUE or LIGHT BLUE	GRAY

- Looking at the end of the metal part of the connector where the wires are inserted, use your fingernail, and gently pull a wire clamp lever down away from the body of the connector.
- Insert the wire into the appropriate connector opening, and then close the wire clamp lever.
- Verify that the wire is being held securely in the connector by lightly pulling on the wire.

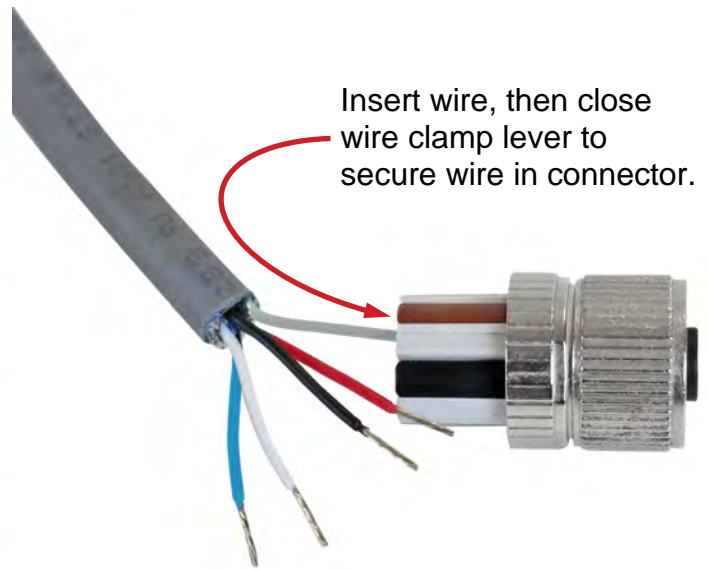
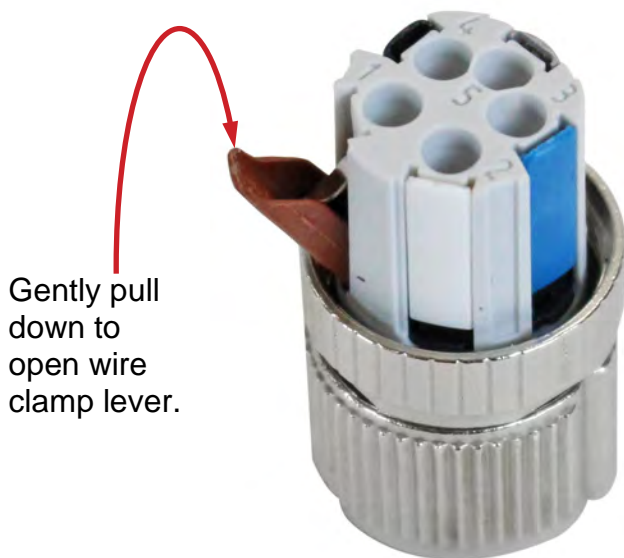

- Repeat steps 4 through 6 until all five wires of the homerun cable are installed in the metal part of the connector.

8. After all connections have been made, slide the black plastic and metal connector parts together, and then screw them together by hand-tightening.



9. To complete the assembly, hold the black and metal parts of the connector housing, and then hand-tighten the cable clamp to the black plastic part of the connector housing.

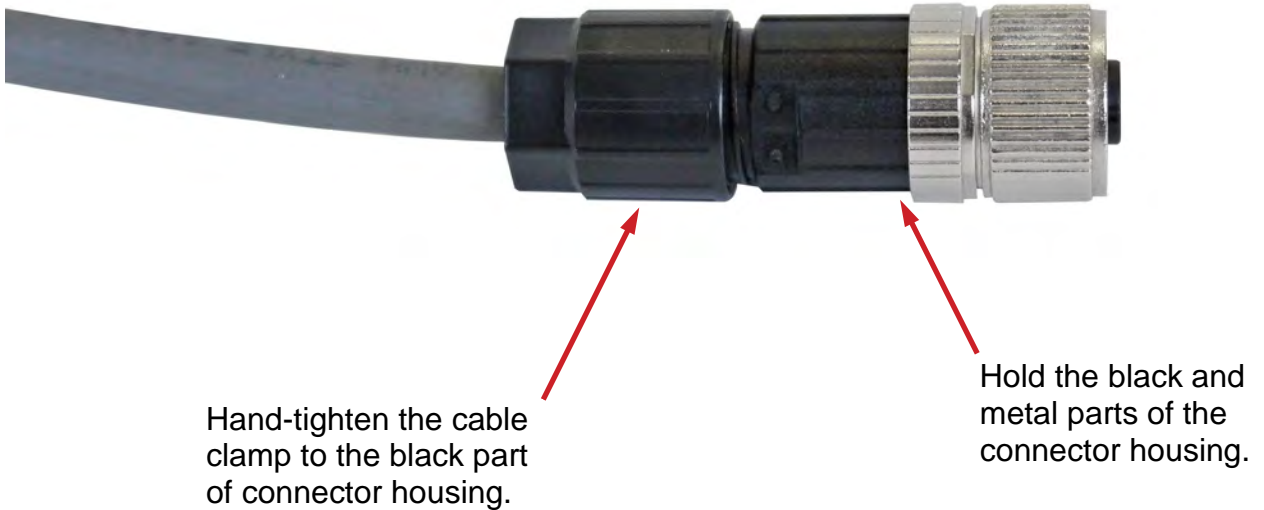

NOTE: For reference, the image below, shows the cable clamp separated from the connector housing in order to view the cable clamp collar.



GROUNDING INSTRUCTIONS

SCBD Scales Grounding Specifications – 3502-0671-GS

1. The ground rod shall be copper plated 0.5 in. (1.27 cm.) minimum diameter, with clean exterior surfaces, and shall not be covered with paint, enamel, or other materials, which are poor conductors.
2. The ground rod shall be embedded below permanent moisture level at least 8 ft. (2.44 m.) where practicable. Where rock bottom is encountered, at depth of less than 4 ft. (1.22 m.), the ground rod shall be buried in a horizontal trench.
3. Connect the weighbridge to the ground rod with a minimum 1.5" (38.1 mm) flat braided cable or ground wire. Clamp the flat braided cable (or ground wire) to the 1.5" x .5" (38.1 mm x 12.7 mm) round stud on the section 2 weighbridge. After installation of the flat braided cable (or ground wire), check for continuity between the conductive scale components and the ground rod.
4. Connect the scale grounding stud to the grounding lug on the indicator, using the supplied 10 GA-(6.0 sq. mm) stranded insulated wire.

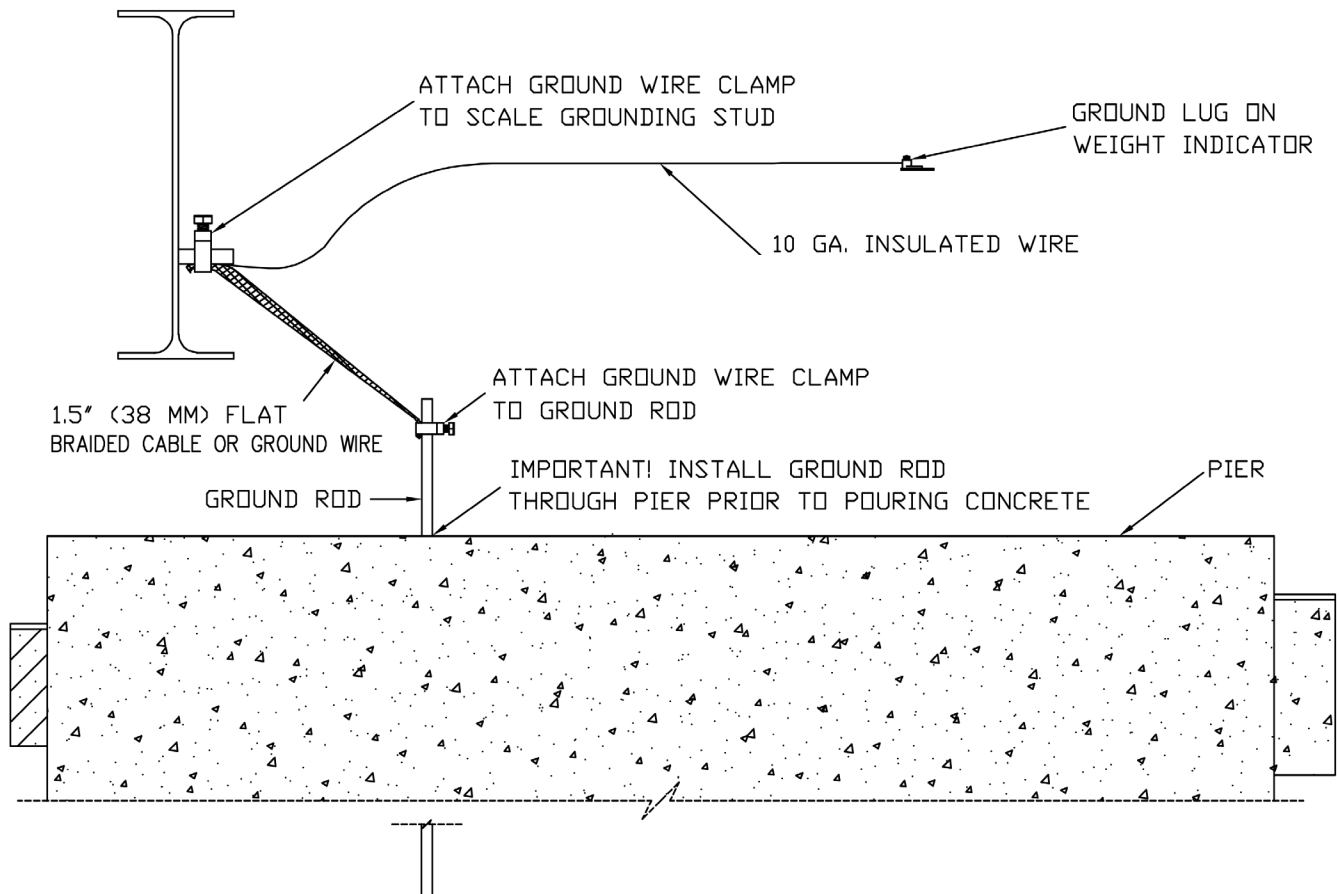
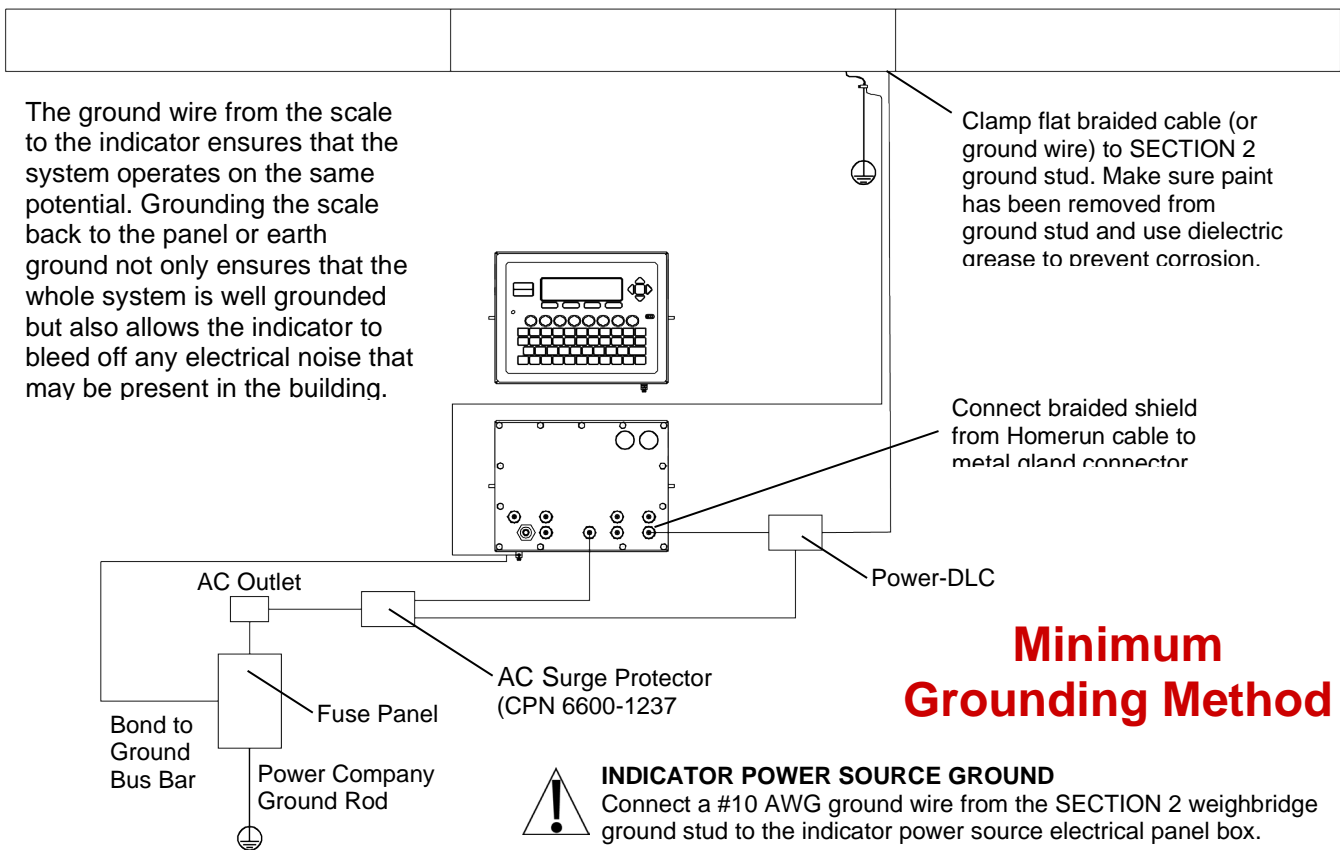
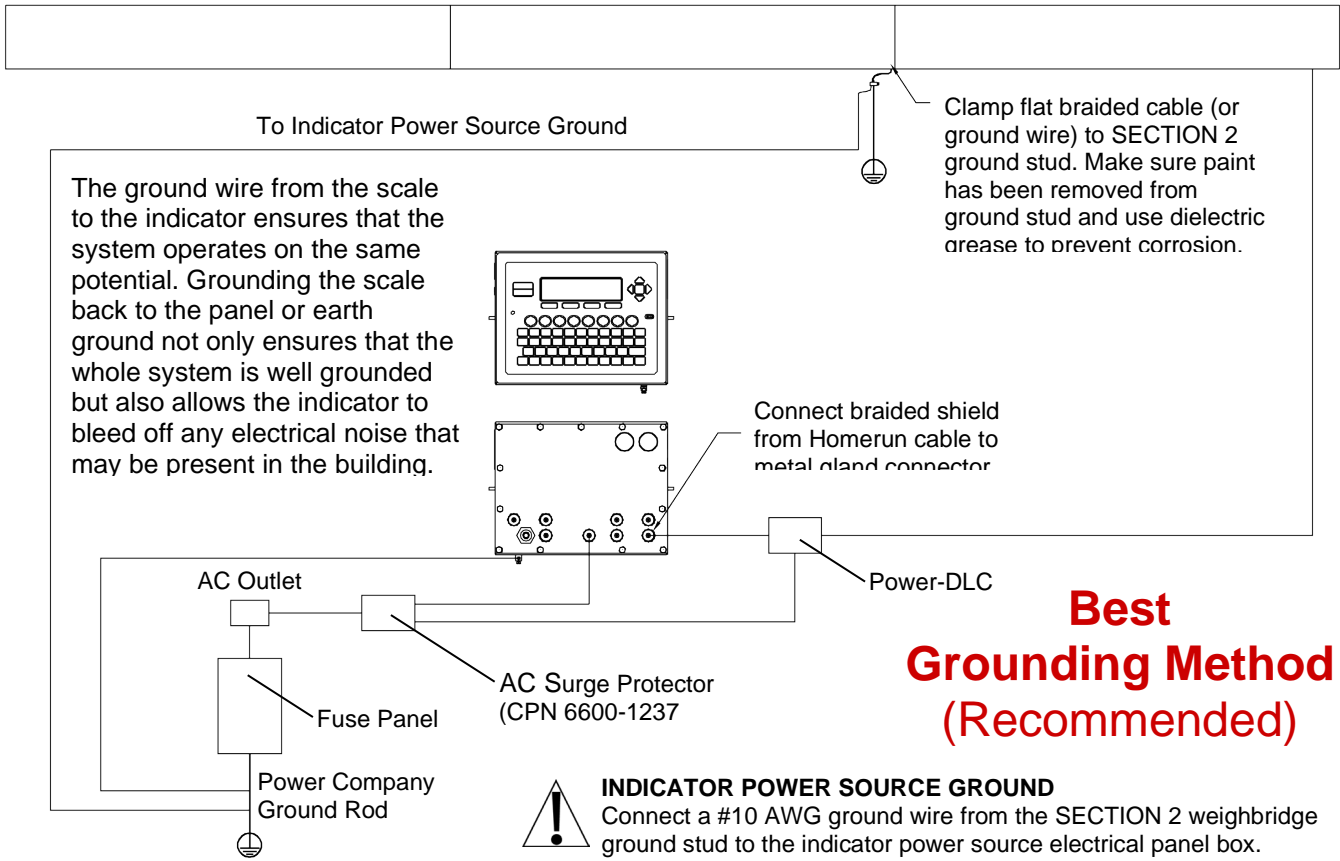

Diagram of Scale and Indicator to Ground Rod per 3520-0671-GS



IMPORTANT! The ground rod should be driven in the ground (through the area for the pier) prior to pouring the concrete. Leave approximately 6 inches of the ground rod exposed above the pier.

Truck Scale Grounding Specifications – 3502-0713-GS



Grounding Instructions for ARMOR Digital Truck Scales

Cardinal Scale Mfg. Co. recommends the following grounding procedures for new and existing installations of ARMOR Digital Truck Scales. This grounding scheme is valid for various soil types and should help minimize downtime and repair costs caused by lightning damage.

SUPPLIED GROUNDING COMPONENTS

Description	Qty.	Part No.
Ground Rod .625" Diameter X 10 Feet.	1	6980-0054
Ground Cable, 1 1/2" Flat Braid #3 AWG	1	6980-0036
Wire #10 AWG Stranded, Green	1	6980-0035
Grounding Clamp	2	6610-5023
Dielectric Grease (<i>included in Homerun Connector bag kit</i>)	1	6050-3056

Site Requirements

1. Make sure the AC outlet the indicator is plugged into is wired correctly. An AC outlet circuit tester can be used to check for proper Line, Neutral, and Earth ground wiring.
2. It is recommended that metal conduits be used with separate conduit runs for the AC power lines and the data lines.
3. To prevent electrical induction into the data lines during a lightning strike, the scale ground wire should be routed in a separate conduit away from the data lines.
4. A surge protector (CPN 6600-1237) is **required** between the AC power source and the indicator.
5. On an existing scale site, the ground rod should be driven into the ground with approximately 6 inches of the ground rod exposed.

NOTE: For a new installation, the ground rod should be driven in the ground (through the area for the pier) prior to pouring the concrete. Leave approximately 6 inches of the ground rod exposed above the pier.

Indicator and Scale Lightning Protection Connections

Follow these steps to ensure the indicator ground and the scale weighbridge ground are at the same potential which is necessary for good lightning protection:

1. Make sure the flat braided cable (or ground wire) and grounding clamp are connected to the ground stud on the SECTION 2 weighbridge of the truck scale. Make sure the paint has been removed from the ground stud and use a dielectric grease (CPN # 6050-3056) to prevent corrosion.
2. Connect the other end of the flat braided wire (or ground wire) near the top of the ground rod so the clamps won't corrode due to ground moisture. Make sure the flat braided wire (or ground wire) has at least a *1-foot loop* to ensure the weight operation is not affected.

3. Connect a #10 AWG or larger copper ground wire from the ground rod clamp to the indicator power source ground (the indicator power source ground is the electrical panel box that provides power to the indicator).



NOTE: If connecting to the electrical panel box is impractical, connect the #10 AWG wire to the indicator power outlet ground.

4. Connect a # 10 AWG ground wire from the indicator's copper ground lug, at the bottom of the 225D enclosure (or back of the 825D enclosure), to the indicator power source ground. *Connect the indicator ground wire at the same point as the scale ground wire.*
5. The truck scale must be inspected periodically to ensure that all connections are tight and that there is no corrosion to the braided cable (or ground wires) or wire clamps. Use an "Earth Ground Resistance Tester" to measure the ground connection. A connection that measures higher than 1 ohm of resistance should be cleaned or replaced.

Scale Ground Stud to Ground Rod Connections

1. Clamp the flat braid cable (or ground wire) to the 1.5" x .5" round stud on the SECTION 2 weighbridge. Make sure the paint has been removed from the ground stud and use the dielectric grease to prevent corrosion.
2. Clamp the other end of the flat braided cable (or ground wire) to the ground rod to connect the weighbridge ground stud to the ground rod. Connect the flat braided cable (or ground wire) near the top of the ground rod so the clamp won't corrode due to ground moisture.
NOTE: Make sure the flat braided cable (or ground wire) has at least a *1-foot loop* to ensure the weight operation is not affected.
3. After the installation of the flat braided cable (or ground wire) has been completed, check for continuity between the conductive scale components (weighbridge) and the ground rod.



**Weighbridge SECTION 2
Ground Stud Connections**
(Flat Braided Cable and Ground Wire to Indicator)



Ground Rod Connection

RODENT GUARD INSTALLATION

Rodent Guard Installation

The Rodent Guard is a combination stainless steel lower guard and guard cover (formerly the cable tray) developed by Cardinal Scale to address the problem of the digital load cell cables being damaged by destructive rodents such as rats and mice in the load cell pockets of ARMOR Digital Truck scales. For steel deck scales, the Rodent Guard includes a two-piece stainless steel lower guard and a two-piece guard cover that replaces the single-piece cable tray. For concrete deck scales, it includes a three-piece stainless steel lower guard and an updated single-piece stainless steel cable tray.

With the Rodent Guard installed, the load cables are completely protected, yet still, allow easy access to them and the SCBD digital load cell by technicians for diagnosing issues or servicing the scale.

The lower pieces of the rodent guard are installed with a small amount of clearance between them and the load cell body which blocks the rodents' access to the load cell cables from the bottom of the load cell pocket. The stainless steel 2-piece guard cover or cable tray is installed over the digital load in the load cell pocket to complete the protection of the load cell cables and still allow any excess cable to be coiled and placed under the scale deck access plate.

The Rodent Guard is also available to retrofit existing ARMOR Digital Truck Scale installations that are experiencing problems with damage to load cell cables due to rodents.



Installed Rodent Guard for 12-Inch Steel Beam Deck Shown

12-Inch Beam Steel Deck Installation



IMPORTANT! Make sure the load cell thread protectors are installed on the load cell to protect the connector threads during the installation of the load cell guards.

Step 1. After removing the shipping brackets and installing the load cell cables into the scale conduit, making sure the ends of the cables only extend a small distance past the edge of the conduit, start on the side of the load cell pocket opening with the load cell connectors.

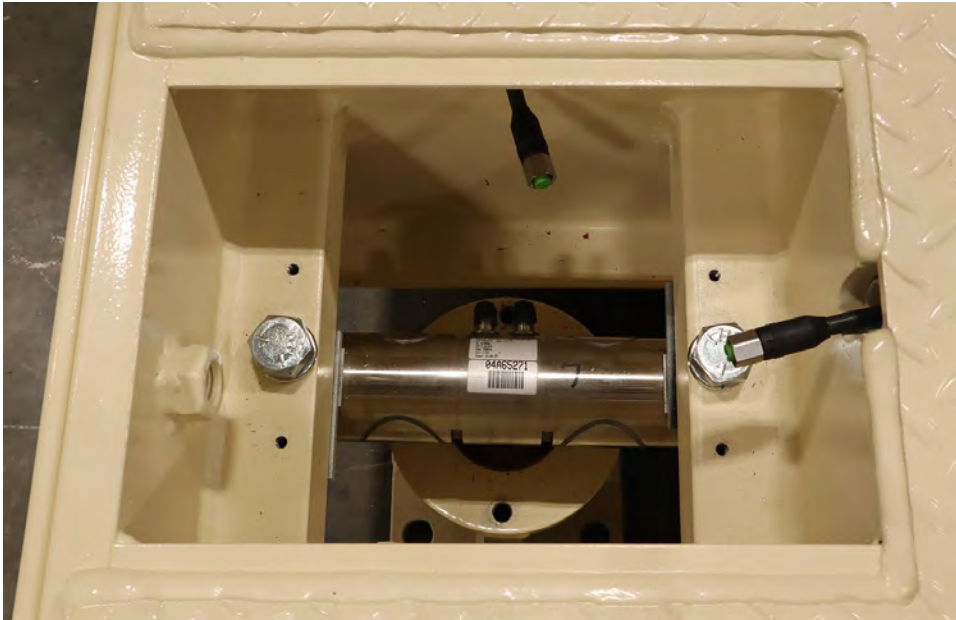

Figure No. 1 – With load cell cables installed, begin on the load cell connector side.

Step 2. Place the first load cell guard in the load cell pocket opening, tilt it at an angle, and then slide it under the load cell cable connectors.



Figure No. 2 – Tilt load cell guard at an angle and slide under load cell cable connectors.

12-Inch Beam Steel Deck Installation, Cont.

Step 3. With the load cell guard under the load cell cable connectors, continue lowering the guard until the edge of it is against the load cell, and then position the holes in the guard evenly over the threaded holes in the scale.



Figure No. 3 – First load cell guard installed and positioned over threaded holes.

Step 4. Place the second load cell guard in the load cell pocket opening, tilt it at an angle, and then lower it until it is against the load cell.



Figure No. 4 – Tilt the second load cell guard at an angle and slide it into the load cell pocket.

12-Inch Beam Steel Deck Installation, Cont.

Step 5. With the second load cell guard in the load cell pocket, position the holes in the guard evenly over the threaded holes in the scale.

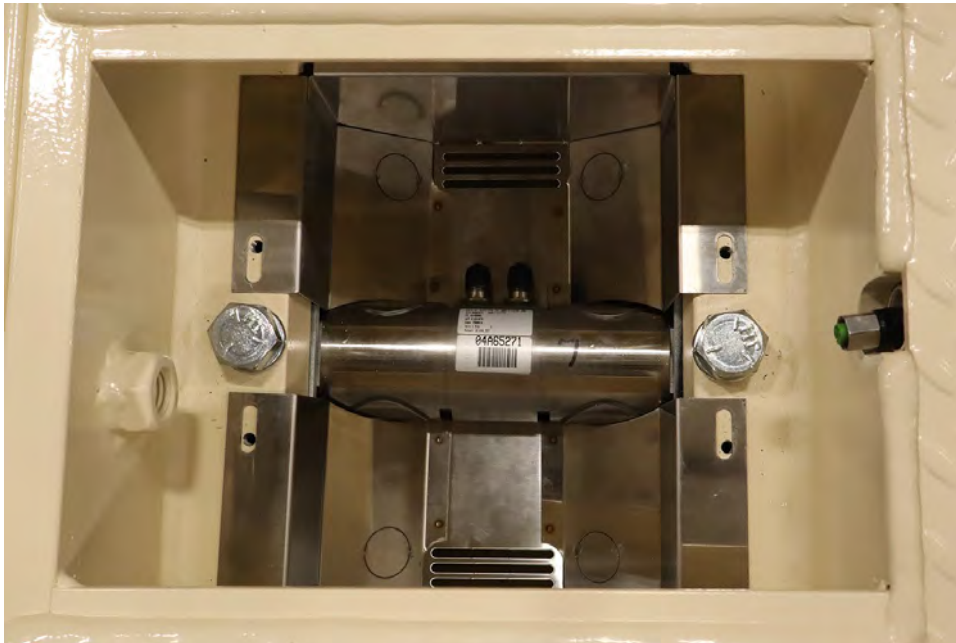

Figure No. 5 – Second load cell guard installed and positioned over threaded holes.

Step 6. With both load cell guards in place, connect the digital load cell cables to the load cell.



Figure No. 6 – Connect the digital load cell cables to the load cell.

⚠ NOTE: Make sure to install the End Node Terminator on the last load cell of the loop.

12-Inch Beam Steel Deck Installation, Cont.

Step 7. With the load cell cables connected, place one load cell guard cover under the load cell cable by tilting it at an angle under the load cell cable and then lowering it into the load cell pocket.



Figure No. 7 – Tilt the load cell guard cover at an angle and slide it under the load cell cable.

Step 8. With the load cell guard cover in the load cell pocket and under the load cell cable, position the holes in the guard cover evenly over the threaded holes in the scale.

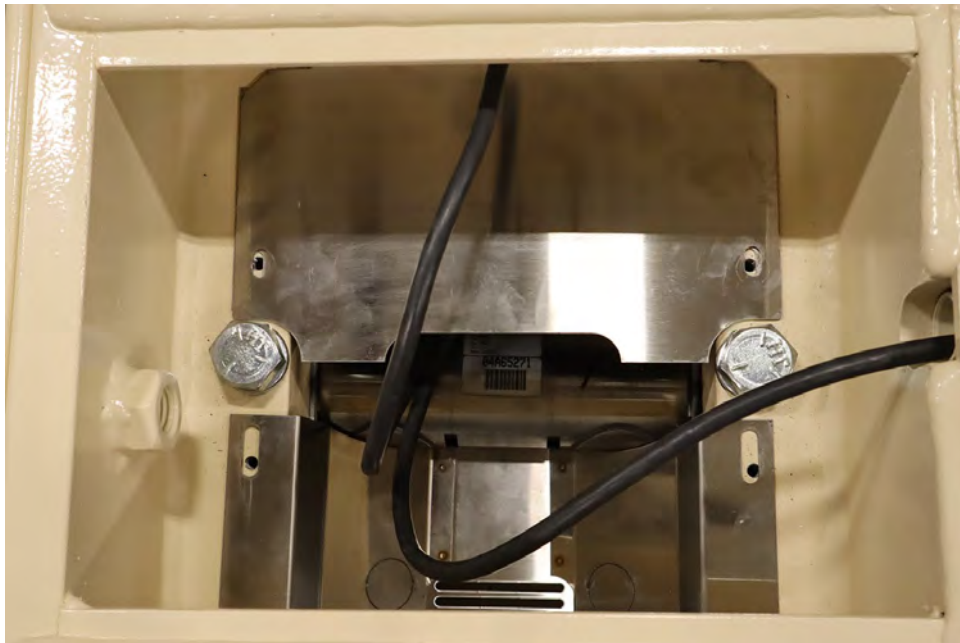

Figure No. 8 – First load cell guard cover installed and positioned over threaded holes.

12-Inch Beam Steel Deck Installation, Cont.

Step 9. Position the load cell cables toward the cut-out in the installed load cell guard cover, and then install the second load cell guard cover by tilting it at an angle and lowering it into the load cell pocket.



Figure No. 9 – Move cables to cut-out then place guard cover into load cell pocket.

Step 10. With the second load cell guard cover in the load cell pocket, align the holes in the guard cover over the threaded holes in the scale.



Figure No. 10 – Second load cell guard cover installed and positioned over threaded holes.

 Note the position of the load cell cables in the cut-outs of the load cell guard covers.

12-Inch Beam Steel Deck Installation, Cont.

Step 11. Install the four 1/4-20 x 3/4 in. hex-head bolts to secure the load cell guards and load cell guard covers in the load cell pocket.



Figure No. 11 – Install four 1/4-20 x 3/4 in. hex head bolts to secure load cell guards and covers.



Figure No. 12 – View of completed Rodent Guard installation.

Step 12. The access plates in the scale are at one end in the corner of the weighbridge. Before installing the access plates, make sure the cables are clear of the access plate opening, then place one side of the access plate in the opening and then lower the other side of the access plate to close the opening.



Figure No. 13 – Installed access plate on 12-inch beam steel deck scale

8-Inch Beam Concrete Deck Installation



IMPORTANT! Make sure the load cell thread protectors are installed on the load cell to protect the connector threads during the installation of the load cell guards.

Step 1. Remove the shipping brackets and start on the side of the load cell pocket opening with the load cell connectors.



Figure No. 1 – Begin on the load cell connector side.

Step 2. Place the outer load cell guard in the load cell pocket opening, tilt it at an angle, and then slide it under the load cell cable connectors.

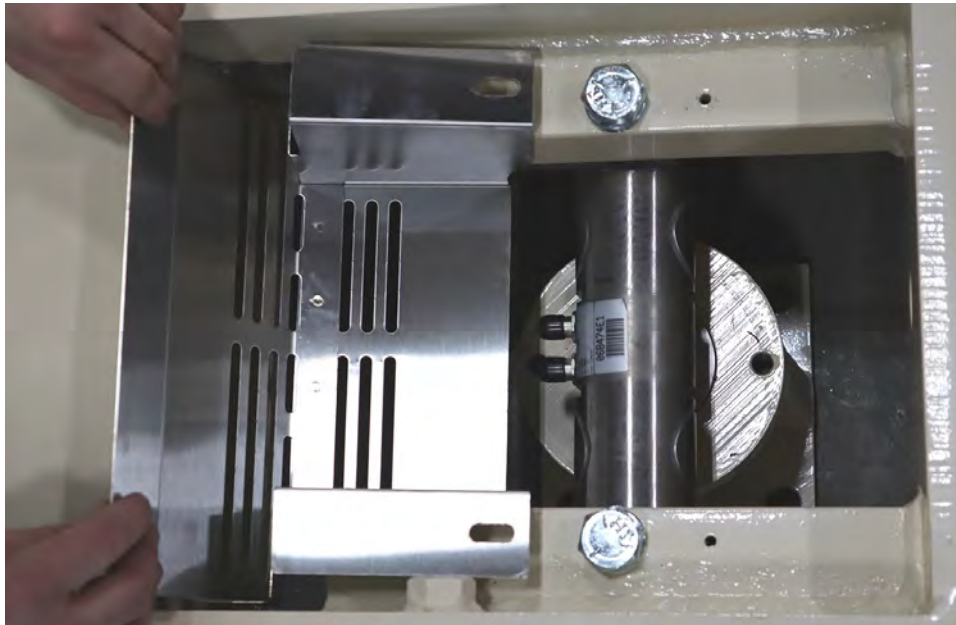

Figure No. 2 – Tilt outer load cell guard at an angle and slide under load cell cable connectors.

8-Inch Beam Concrete Deck Installation, Cont.

Step 3. With the outer load cell guard under the load cell cable connectors, continue lowering the guard until the edge of it is against the load cell, and then position the holes in the guard evenly over the threaded holes in the scale.

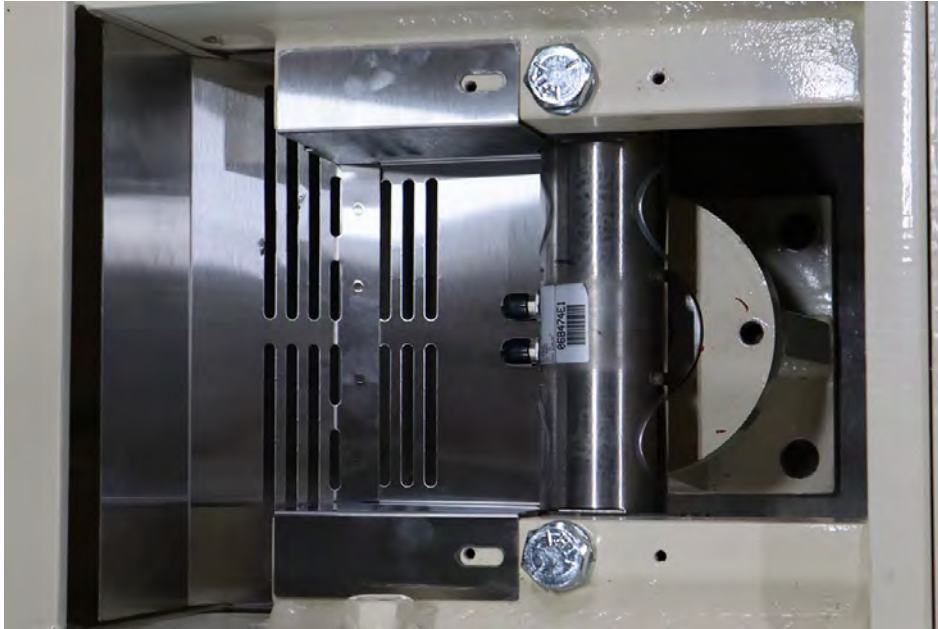

Figure No. 3 – Outer load cell guard installed and positioned over threaded holes.

Step 4. Place the inner load cell guard in the load cell pocket opening, tilt it at an angle, and then lower it until it is against the load cell.

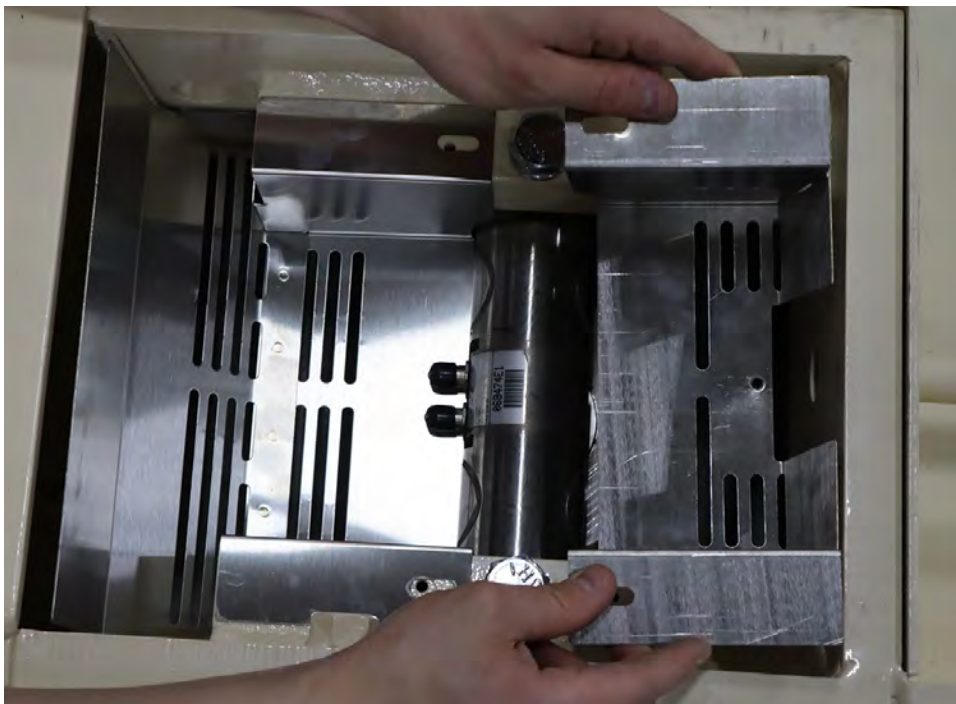

Figure No. 4 – Tilt the inner load cell guard at an angle and slide it into the load cell pocket.

8-Inch Beam Concrete Deck Installation, Cont.

Step 5. With the inner load cell guard in the load cell pocket, position the holes in the guard evenly over the threaded holes in the scale.

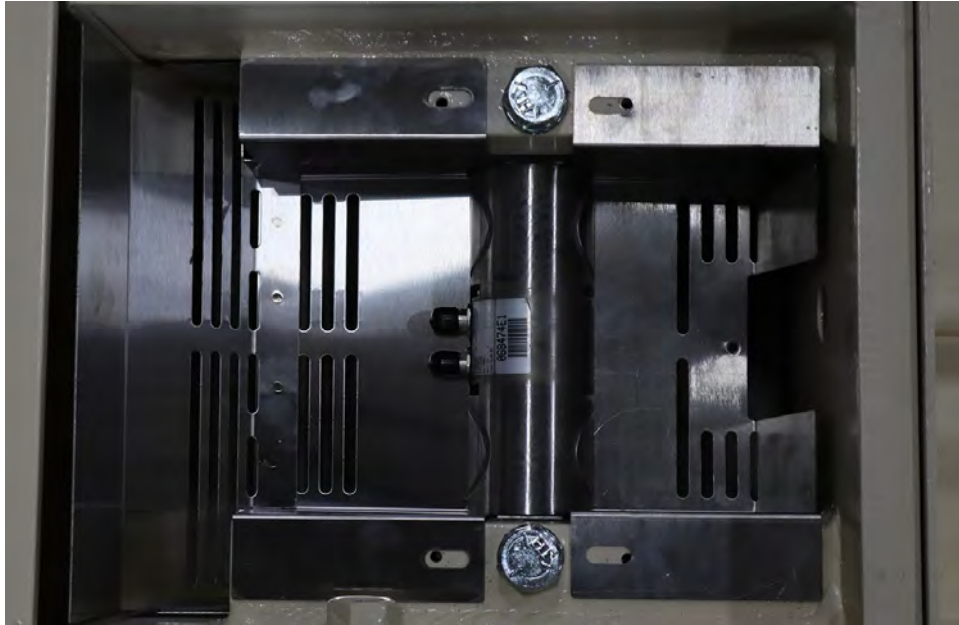

Figure No. 5 – Inner load cell guard installed and positioned over threaded holes.

Step 6. With both load cell guards in place, install the small inner guard plate in the notch of the inner load cell guard. To install it, squeeze the sides of the inner guard plate together and then insert it in the notch of the inner guard. Position it against the load cell pocket wall and down against the inner guard, aligning the slot in the inner guard plate with the hole in the inner load cell guard.

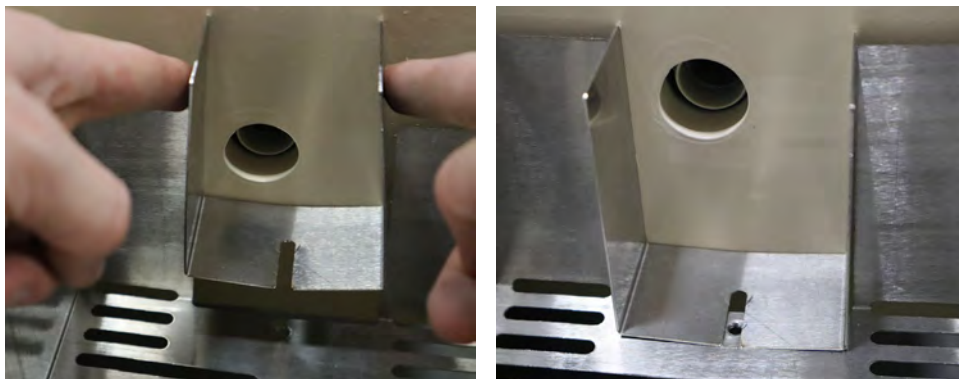

Figure No. 6 – Install the inner guard plate and align the slot with the hole in the inner load cell guard.

8-Inch Beam Concrete Deck Installation, Cont.

Step 7. With the inner guard plate in position, secure it to the inner guard using the #10 x .75 in hex-head, indented hex washer, self-tapping screw.



Figure No. 7 – Use the #10 x .75 in self-tapping screw to secure the inner guard plate to the inner load cell guard.

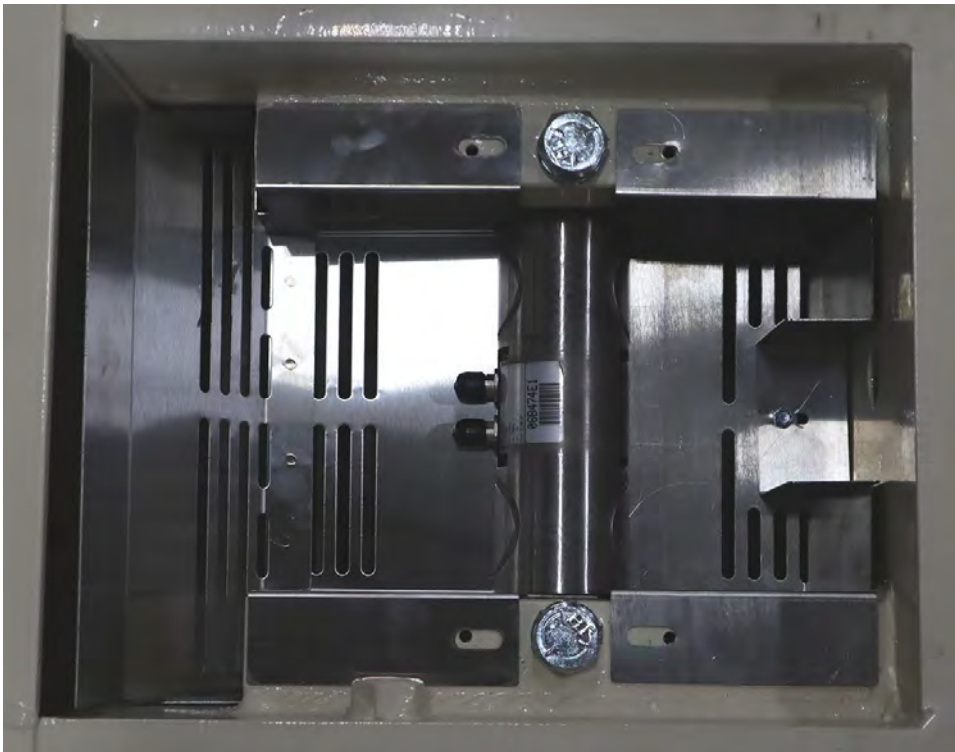

Figure No. 8 – View of both load cell guards and inner guard plate installed.

8-Inch Beam Concrete Deck Installation, Cont.

Step 8. With both load cell guards and the inner guard plate in place, install, and connect the digital load cell cables to the load cell.

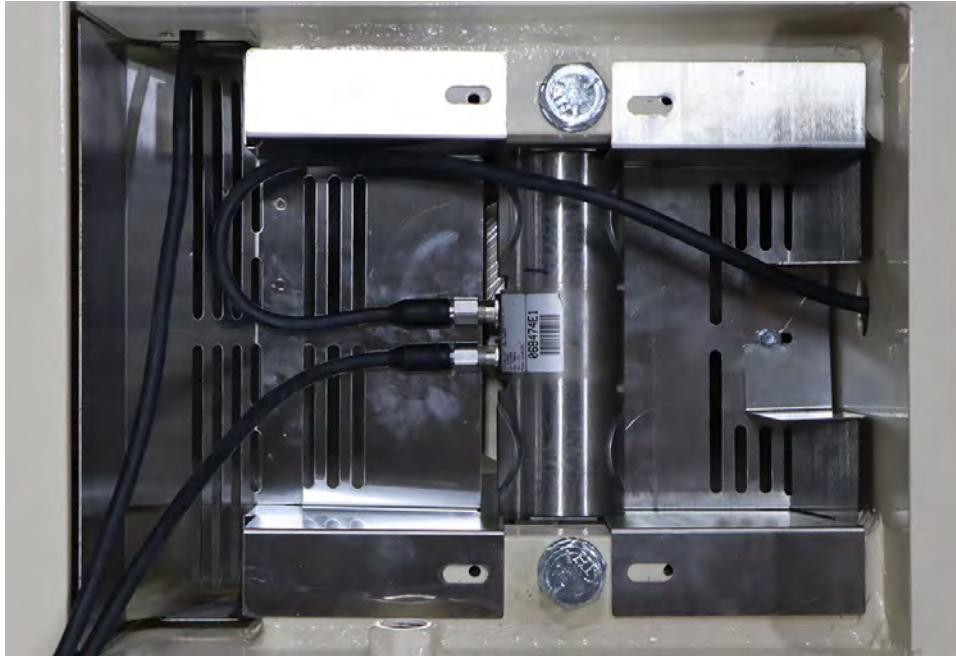

Figure No. 9 – Connect the digital load cell cables to the load cell.

⚠ NOTE: Make sure to install the End Node Terminator on the last load cell of the loop.

Step 9. With the load cell cables connected, place the stainless steel cable tray under the load cell cables and then lower it into the load cell pocket.



Figure No. 10 – Place the stainless steel cable tray under the cables in the load cell pocket.

8-Inch Beam Concrete Deck Installation, Cont.

Step 10. Align the holes in the stainless steel cable tray over the threaded holes in the scale and install the four 1/4-20 x 3/4 in hex-head bolts to secure the load cell guards and the stainless steel cable tray in the load cell pocket.

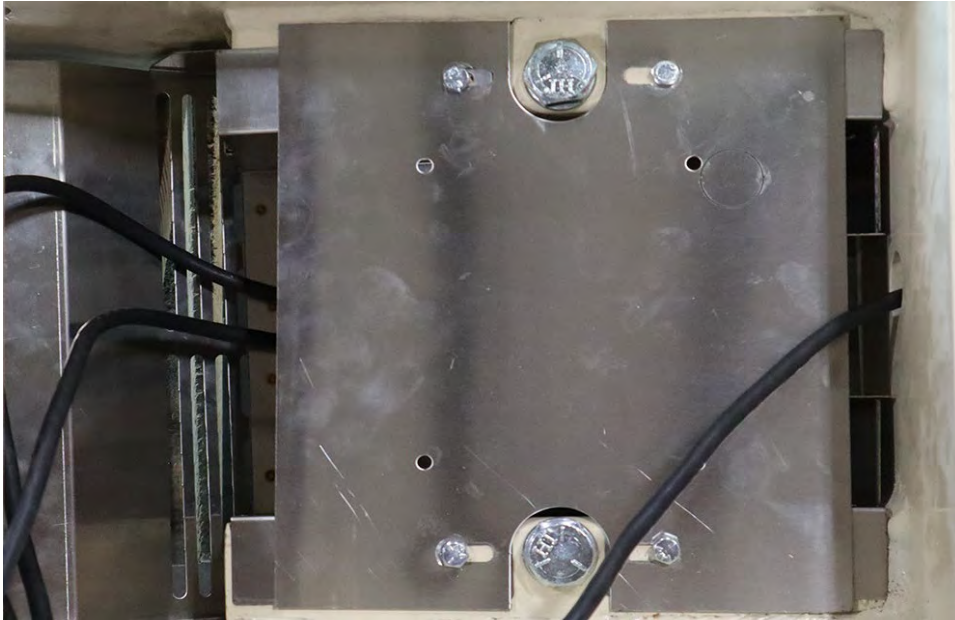

Figure No. 11 – Install the 1/4-20 x 3/4 in. hex head bolts to secure the load cell guards and stainless steel cable tray.

Step 11. Coil any excess load cell cable and place it on the stainless steel cable tray in the load cell pocket before installing the access cover.



Figure No. 12 – Coil excess cable and place on the stainless steel cable tray.

Step 12. The access plates in the scale are at one end in the corner of the weighbridge. Before installing the access plates, make sure the cables are clear of the access plate opening, then place one side of the access plate in the opening and then lower the other side of the access plate to close the opening.



Figure No. 13 – Installed access plate on 8-inch beam concrete deck scale

10-Inch Beam Concrete Deck Installation



IMPORTANT! Make sure the load cell thread protectors are installed on the load cell to protect the connector threads during the installation of the load cell guards.

Step 1. Remove the shipping brackets and start on the side of the load cell pocket opening opposite the load cell connectors.



Figure No. 1 – Begin on the side opposite the load cell connectors.

Step 2. Place the inner load cell guard in the load cell pocket opening, tilt it at a slight angle, and then lower it into the load cell pocket.



Figure No. 2 – Tilt the inner load cell guard at an angle, then lower it into the load cell pocket.

10-Inch Beam Concrete Deck Installation, Cont.

Step 3. With the inner load cell guard in the pocket, continue lowering it until it is against the load cell with the holes in the guard positioned over the threaded holes in the scale.



Figure No. 3 – Inner load cell guard installed and positioned over threaded holes.

Step 4. With the inner load cell guard in place, install the small inner guard plate in the notch of the inner load cell guard. To install it, squeeze the sides of the inner guard plate together and then insert it in the notch of the inner guard. Position it against the load cell pocket wall and down against the inner guard, aligning the slot in the inner guard plate with the hole in the inner load cell guard.

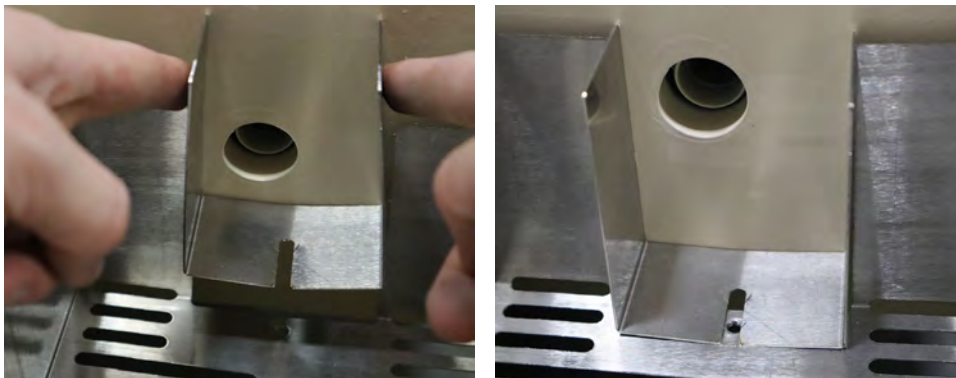

Figure No. 4 – Install the inner guard plate and align the slot with the hole in the inner load cell guard.

10-Inch Beam Concrete Deck Installation, Cont.

Step 5. With the inner guard plate in position, secure it to the inner guard using the #10 x .75 in hex-head, indented hex washer, self-tapping screw.



Figure No. 5 – Use the #10 x .75 in self-tapping screw to secure the inner guard plate to the inner load cell guard.

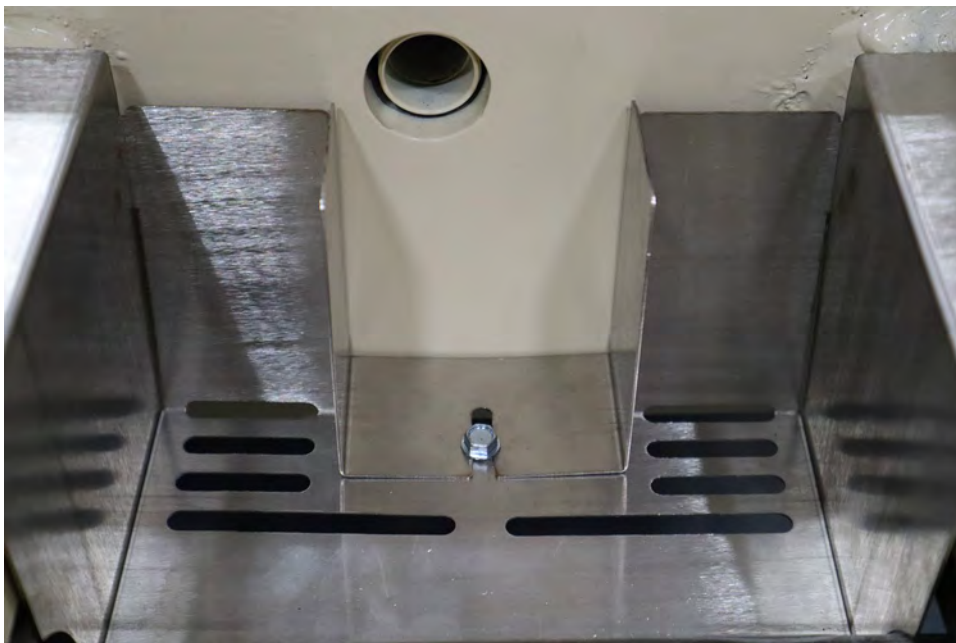

Figure No. 6 – View of inner load cell guard installed on inner load cell guard.

10-Inch Beam Concrete Deck Installation, Cont.

Step 6. Place the outer load cell guard in the load cell pocket opening, tilt it at an angle, and then lower it into the load cell pocket.



Figure No. 7 – Tilt the outer load cell guard at an angle and lower it into the load cell pocket.

Step 7. Push the outer load cell guard into the back of the load cell pocket opening, tilt the front edge of the guard down at an angle, and then pull it forward positioning the front edge of the guard under the load cell connectors.



Figure No. 8 – Push the outer load cell guard into the load cell pocket opening, tilt it at an angle, and then pull it forward under the load cell connectors.

10-Inch Beam Concrete Deck Installation, Cont.

Step 8. With the outer load cell guard in the load cell pocket and positioned under the load cell connectors, position the holes in the guard over the threaded holes in the scale.

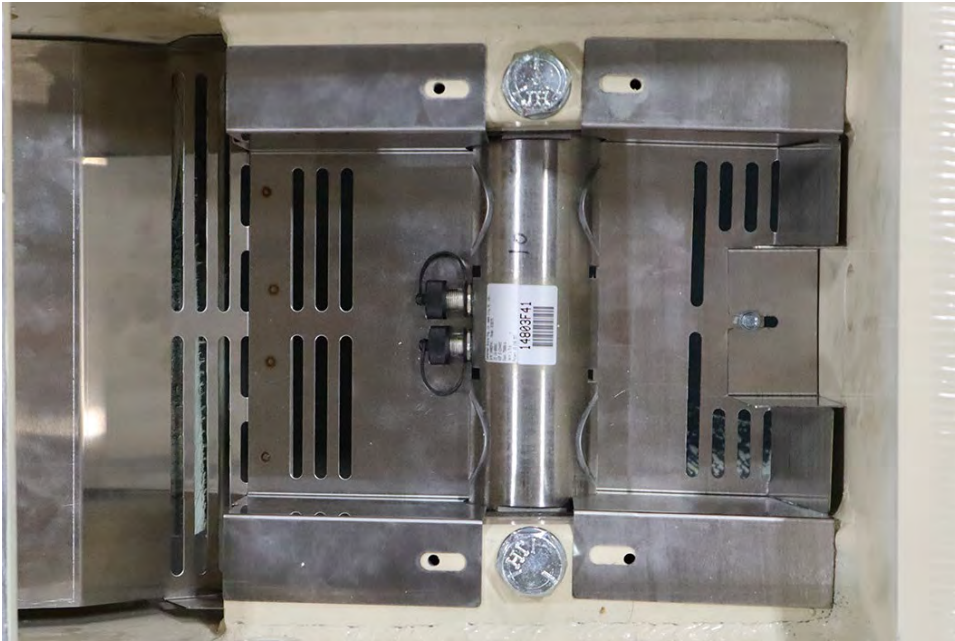

Figure No. 9 – Outer load cell guard installed and positioned over threaded holes.

Step 9. With both load cell guards and the inner guard plate in place, install, and connect the digital load cell cables to the load cell.

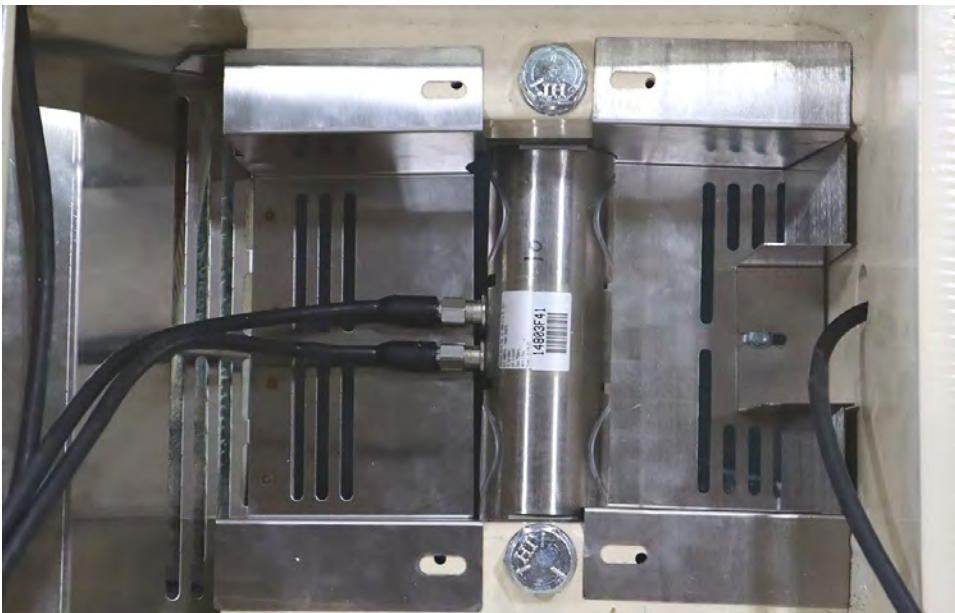

Figure No. 10 – Connect the digital load cell cables to the load cell.

⚠ NOTE: Make sure to install the End Node Terminator on the last load cell of the loop.

10-Inch Beam Concrete Deck Installation, Cont.

Step 10. With the load cell cables connected, place the stainless steel cable tray under the load cell cables and then lower it into the load cell pocket.



Figure No. 11 – Place the stainless steel cable tray under the cables in the load cell pocket.

Step 11. Align the holes in the stainless steel cable tray over the threaded holes in the scale and install the four 1/4-20 x 3/4 in hex-head bolts to secure the load cell guards and the stainless steel cable tray in the load cell pocket.

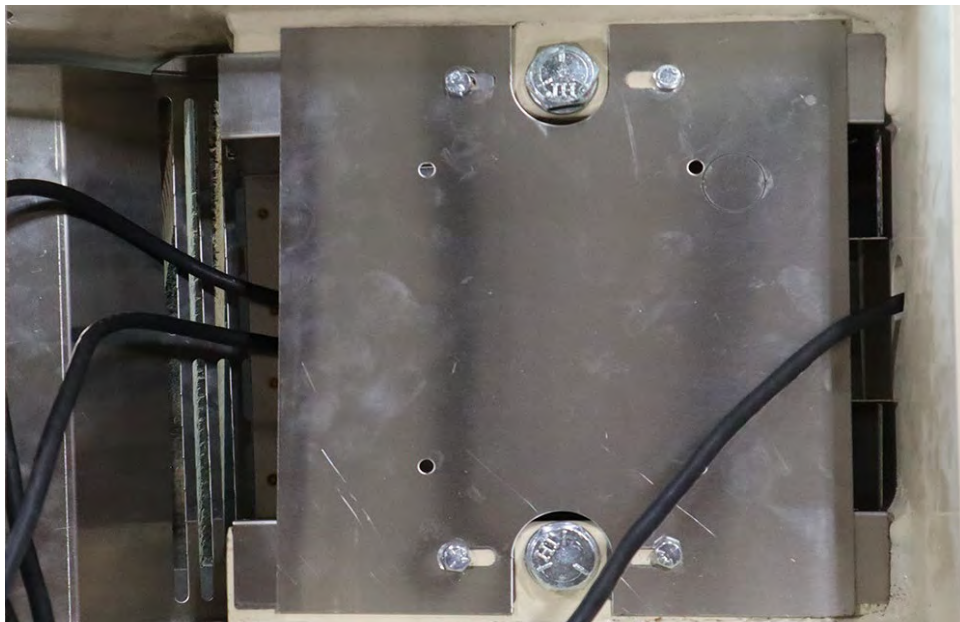

Figure No. 12 – Install the 1/4-20 x 3/4 in hex head bolts to secure the load cell guards and the stainless steel cable tray.

10-Inch Beam Concrete Deck Installation, Cont.

Step 12. Coil any excess load cell cable and place it on the stainless steel cable tray in the load cell pocket before installing the access cover.



Figure No. 13 – Coil excess cable and place on the stainless steel cable tray.

Step 13. The access plates in the scale are at one end in the corner of the weighbridge. Before installing the access plates, make sure the cables are clear of the access plate opening, then place one side of the access plate in the opening and then lower the other side of the access plate to close the opening.



Figure No. 14 – Installed access plate on 10-inch beam concrete deck scale

DIGITAL SCALE SETUP AND CONFIGURATION

Digital Scale Setup and Configuration

The SCBD SmartCell® digital load cells used in Cardinal Scale's ARMOR® Digital Truck Scale are connected using a daisy-chained CAN (Controller Area Network) cable. The load cell connection loop can begin at any load cell on the scale and may continue clockwise or counter-clockwise if preferred.

For example, in the illustration below, the connection loop begins with load cell 4 and runs clockwise ending with the end node terminator on load cell 6. Also, note that there is not a connection between load cell 4 and load cell 6.



IMPORTANT! Be sure to insert the end node termination plug on the load cell at end of the loop as shown in the example.

Example: Typical Truck Scale Configuration

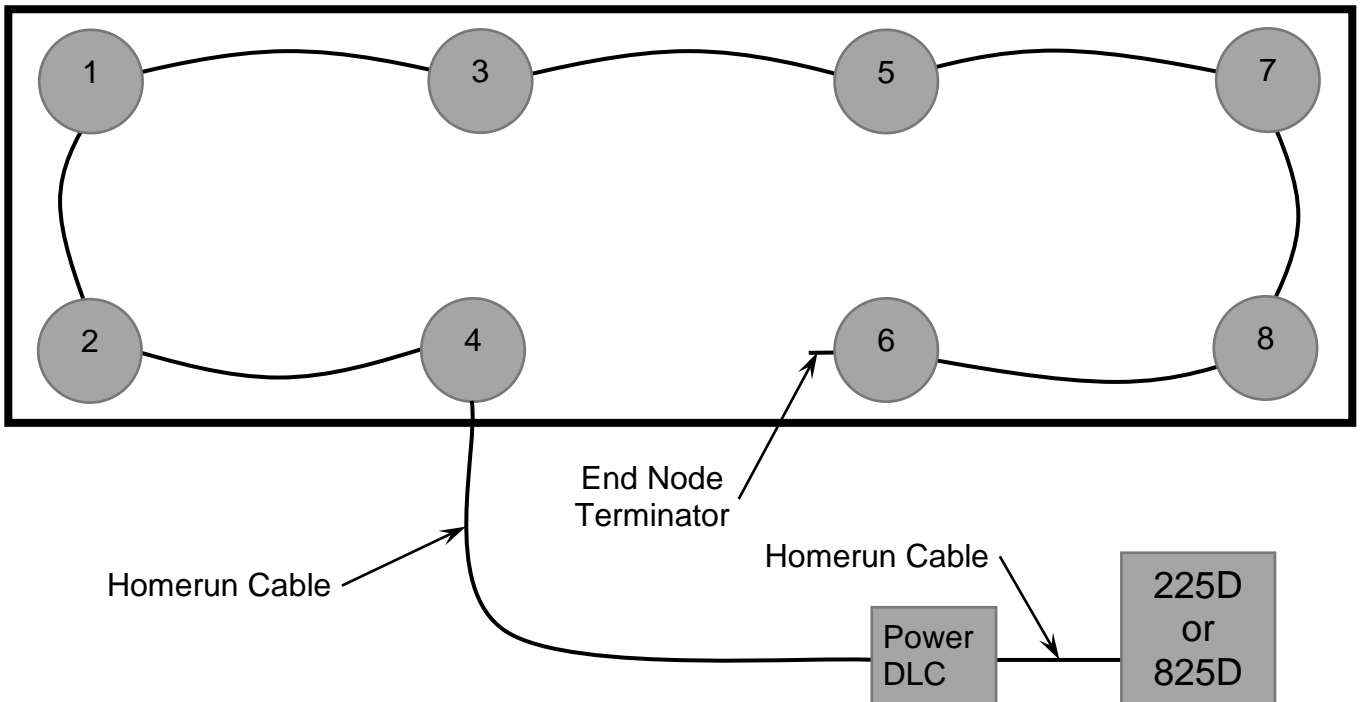

NOTE: If the loop were run in the other direction, the sequence would then be 6-8-7-5-3-1-2-4 with load cell 4 having the End Node Terminator installed on it.

225D Setup and Configuration

Addressing Cells

Each cell has a serial number (S/N) marked on the cell. This is an 8-digit hexadecimal number. It is also known as the cell ID. Each cell ID must be matched with a cell address. In the example on the previous page, the addresses would be 1-8.

1. Enter the SETUP menu by pressing **SHIFT+RED_KEY**.
2. Press **ENTER** again to get to SETUP MENU #1.
3. Press **8** and **ENTER** to set the number of scales and cells.

```
          SETUP MENU #1
1.  USA=XXX          6.  CLR TARE=XXX
2.  NSC=XXX          7.  CLEAR ID=XXX
3.  LFT=XXX          8.  SCALES=X CELLS=X
4.  OIML=N/A        9.  TOTALIZE=XXX
5.  TIME=XX         10. MODE OF OP=1  IDS
Enter Selection: 0  [F4]NEXT [F5]EXIT
```

4. Enter the number of scales and press **ENTER**.
5. Enter the number of cells and press **ENTER**. The addressing menu will appear.

```
          CELL TO SCALE ASSIGNMENTS
1.  CELL 1  SCALE=1  ID=1D7A173F  START
2.  CELL 2  SCALE=1  ID=0EB0EBFF  END
3.  CELL 3  SCALE=1  ID=18B8783F
4.  CELL 4  SCALE=1  ID=09C99FFF

Enter Selection: 0  [F4]NEXT [F5]EXIT
                   END NODES  EXIT
```

6. Press a cell number, and then **ENTER** to be prompted for the associated scale number followed by the cell ID.
7. If the cell is found, the indicator will display "CELL RESPONDED". If the cell does not respond the 225D will sound an error beep and display "—FAILED—". If the cell is disconnected, then this error can be ignored.

End Nodes

The 225D also needs to know where the scale starts and ends. The START NODE is the cell that is connected to the SCALE connection of the POWER-DLC. The END node is the last cell in the daisy chain. In the example on the previous page, the START node is #4 and the END node is #6.

End Nodes, Cont.

To set the nodes:

1. Press the **END NODES** soft key.
2. The 225D will display “WHICH CELL CONNECTS TO THE 225? “.
3. In the previous example, the user would enter **4** and **ENTER**.
4. The 225D will display “WHICH CELL IS THE LAST IN THE LOOP? “.
5. In the previous example, the user would enter **6** and **ENTER**.

225D Calibration

If, after test loading the scale, it is determined that adjustments are required, follow the procedure below. This section describes the procedure necessary to calibrate a Cardinal Digital Truck Scale.

1. Before any adjustments are made, turn on the power to the digital weight indicator.
2. Drive a test truck across the scale *at least three times* in each direction before calibrating the scale.
3. Before any sealing can be done, the weight indicator must be calibrated to the scale. A division size of 10 lbs should be selected and the auto-zero function turned off. Refer to the 225 Weight Indicator Installation and Technical Manual.

All digital cells are pre-calibrated for span in the factory. That means that span calibration is not necessary to start making weights. Only a zero calibration is necessary. However, a Smart Calibration is still usually necessary to trim the corners and sections of a scale.

Navigating to the DLC Calibration Menu

1. Enter SETUP by pressing **SHIFT+RED_KEY**.
2. Press **ENTER**.
3. Press **DOWN** to get to SETUP MENU #2.
4. Select **SETUP SCALE #X** where ‘X’ is the scale number.
5. Press **DOWN** to get to SCALE X SETUP MENU #2.
6. Enter **10** and press **ENTER** to open the DLC calibration menu.

```
SCALE 1 CALIBRATION MENU
1. SMART CALIBRATION
2. ZERO CALIBRATION
3. TRIM CELL(S)
4. SPAN ADJUST

Enter Selection: 0

EXIT
```



IMPORTANT! It is very important that the dead load of the weighbridge is evenly distributed between the pair of cells in a section, before calibrating the scale. Refer to the **Balancing Weighbridge Dead Load** section on page 107 of this manual for more instructions.

SMART CALIBRATION

Smart Calibration is not necessary to make weight, but it is helpful for trimming all load cells automatically.

1. Press **1** and **ENTER**. The 225D will prompt for “CAL WT = 0”.
2. Enter the weight of the test weight.
3. The 225D will display...
VERIFY SCALE IS EMPTY
PRESS ENTER TO CONTINUE
4. With an empty scale, press **ENTER**. This will capture the calibrated dead load weight of the scale.
5. The 225D will display...
PLACE WEIGHT ON CELL X
PRESS ENTER TO CONTINUE
6. Center the weight over scale X and press **ENTER** to take a weight sample.
7. Repeat steps 5, 6 for each cell in the order that the 225D prompts for. (This is the same order as other Cardinal scales, for example, 1, 3, 5, 7, 9, 10, 8, 6, 4, 2).

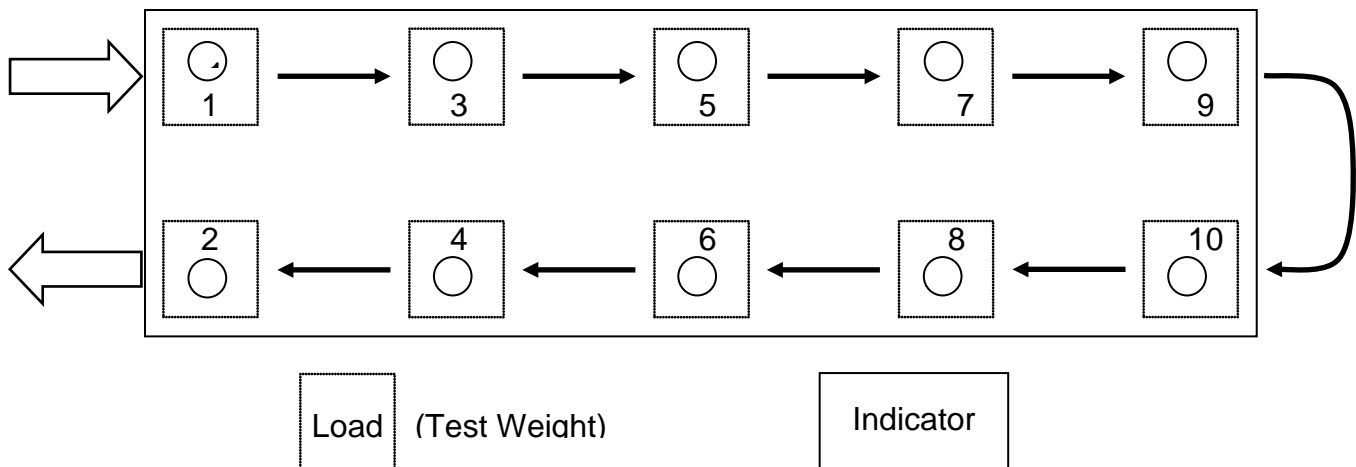

ZERO CALIBRATION

Zero Calibration does not affect the trimming of the cells or affect span. It simply sets the dead load weight of the scale.

1. Press **2** and **ENTER**.
2. The 225D will display...
VERIFY SCALE IS EMPTY
PRESS ENTER TO CONTINUE
3. Ensure the scale is empty and press **ENTER**. The scale will record dead load weight.

TRIM CELLS

Individual cells or pairs of cells may be trimmed. This requires a test load weight.

1. Press **3** and **ENTER**.
2. The 225D will prompt for "Cell Number(s):".
3. To trim a single cell, enter the cell number, and press **ENTER**. To trim a pair of cells, enter both cells in the form "X + Y", and press **ENTER**.
E.g., to trim the pair of cells 5 and 6 enter "**5+6**" and press **ENTER**.
4. For information only, the 225D will display the cell trim "CELL # TRIM X.XXXXXXX". It will also display the total "SCALE WT = XXXXXX".
NOTE: High-resolution weight (interval/10) will be shown if the weight interval setting is less than 10. For example, an interval of 5 will be shown in 0.5 increments.
5. Place a test weight over the cell(s) to be adjusted.
6. Press the **SET_WT** soft key.
7. The 225D will prompt "ENTER NEW WEIGHT =".
8. Enter the actual correct weight of the test weight and press **ENTER**.
9. The 225D will automatically trim the cell to match the entered test weight.
10. Press the **PREVIOUS** and **NEXT** soft keys to navigate to other cells without exiting the trim menu.

SPAN ADJUST

Span adjust allows the user to tweak the span of the entire scale at once.

1. Press **4** and **ENTER**.
2. The 225D will display the current live scale weight "SCALE WT = XXXXX.X".
NOTE: High-resolution weight (interval/10) will be shown if the weight interval setting is less than 10. For example, an interval of 5 will be shown in 0.5 increments.
3. Note that high-resolution weight (interval/10) will be shown if the weight interval setting is less than 10. For example, an interval of 5 will be shown in 0.5 increments.
4. Place the test weight at any location on the scale.
5. Press **SET_WT** soft key. The 225D will prompt "ENTER NEW WEIGHT =".
6. Enter the value of the test weight and press **ENTER**.
7. The 225D will adjust the span to the target weight.

Login

1. With the **Login** screen and prompt displayed, use the alphanumeric keys to enter the login, and then press the ▾ Down Arrow to advance to the password prompt
2. Enter the password using the alphanumeric keys, and then press the **ENTER** key to proceed with Setup and Configuration.



NOTE: The 825D will arrive from the factory with the calibration access locked by the “login” and “password” prompts protection. The factory default login and password are “ADMIN” and “81440”.

3. The display will change to show the **Setup Menu** screen.

```
Setup Menu
Press :
1. Date/Time
2. Communication
3. Calibration
4. Update software menu
5. Preferences
6. Diagnostics
7. Operators

MAC Address: 70:B3:D5:48:85:84
```

3. Calibration

With the Setup Menu displayed, press the **3** key, or use the Navigation Keys to select (highlight) **3. Calibration**, and then press the **ENTER** key. The display will change to show the **Setup Scale Number** screen.

Setup Scale Number

Setup Scale Number

With the Setup Scale Number screen displayed, press the **D** key, or use the Navigation Keys to select (highlight) **D. Configure DLC**, and then press the **ENTER** key. The display will change to show the **Setup DLC Card 1** screen.

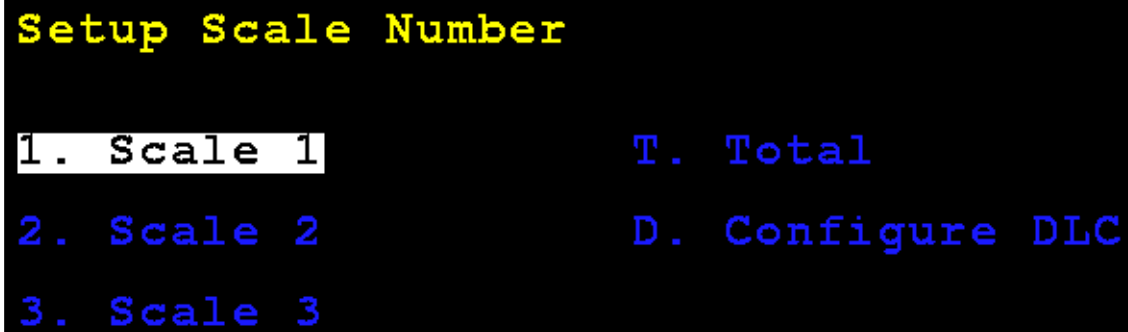

The screenshot shows a menu titled "Setup Scale Number" in yellow text on a black background. The menu items are listed in two columns. The first column contains "1. Scale 1", "2. Scale 2", and "3. Scale 3". The second column contains "T. Total" and "D. Configure DLC". The "1. Scale 1" item is highlighted with a white background.

```
Setup Scale Number  
  
1. Scale 1          T. Total  
2. Scale 2          D. Configure DLC  
3. Scale 3
```

Setup DLC Card 1

```
Setup DLC Card 1

Scales:      3  iSITE SO:123456
Cells:       12 DHCP:      No
First Cell:  1  IP:        192.168.75.210
Last Cell:   2  Netmask:   255.255.255.0
              Gateway:    192.168.75.1

              Man DNS:    Yes
              DNS 1:      8.8.8.8
              DNS 2:      8.8.4.4

              Advanced:  No
```

Scales: – Set the number of scales.

Cells: – Set the total number of cells.

First Cell: – Set the cell number that is connected to the 825D indicator.

Last Cell: – Set the cell number of the end of the chain of load cells.

iSITE SO: – Set Sales Order or another identifier for communications link to iSite cloud.

DHCP: – Set to **Yes** for automatic configuration of the DLC card Ethernet parameters from a DHCP server.

Set to **No** for manual configuration.

Setup DLC Card 1, Cont.

If **DHCP :** = **No**, the following prompts will be visible:

IP : – Set the IP address.

Netmask : – Set the netmask.

Gateway : – Set the network gateway setting.

Man DNS : – Set the domain server addresses.

DNS1 : – Shown if **Man DNS :** set to Yes. Input first DNS IP address.

DNS2 : – Shown if **Man DNS :** set to Yes. Input second DNS IP address.

Advanced : – Set to **No** by default. Press **ENTER** to save any changes. The display will change to show the **DLC CARD 1 CELL ASSIGNMENT** screen.

Set to **Yes** and then press **ENTER** to save any changes. The display will change to show the **Setup DLC Card 1** Advanced screen.

Setup DLC Card 1 – Advanced Screen

Setup DLC Card 1

Server:Yes Port:10001

Ping: Yes

:www.aws.com

13.249.72.61 17ms

13.249.72.61 17ms

13.249.72.61 17ms

13.249.72.61 17ms

Press any key

The **Server** prompt should normally be set to **No**.

Set to **Yes** to perform diagnostic server function (similar to old-style iSite).

If **Server** is set to **Yes**, the **Port** prompt will be shown to set the port.

If **Ping** is set to **Yes**, an input line will be shown.

NOTE: The input line is the colon (:) displayed below **Ping:**. Also, **Ping** will default to www.aws.com but may be changed to other URLs.

Press **ENTER** to perform the ping function.

Over several seconds the ping will occur and display the results of the resolved IP address, along with the response time in milliseconds.

Setup DLC Card 1 – Advanced Screen, Cont.

If a URL is input that does not respond, the display will show the web address and TIMEOUT indicating the URL is not responding to the ping.

```
Setup DLC Card 1

Server:Yes   Port:10001

Ping: Yes
:WWW.NOTREALSITE.COM

199.59.242.153  TIMEOUT
199.59.242.153  TIMEOUT
199.59.242.153  TIMEOUT
199.59.242.153  TIMEOUT

Press any key
```

For example, the URL used in the above screen, WWW.NOTREALSITE.COM has a DNS record but shows TIMEOUT because it is not responding to the ping.

Setup DLC Card 1 – Advanced Screen, Cont.

If the name cannot be resolved to an IP address via DNS the display will show:

Setup DLC Card 1

Server: **Yes** Port: **10001**

Ping: **Yes**

: **WWW.JJSEASKCCERIOP.NET**

WWW.JJSEASKCCERIOP.NET NOT FOUND

Press any key

DLC Card 1 Cell Assignment

The left side of the column shows the existing programmed IDs and scale numbers assigned for each cell.

If any cells are detected on the bus that are not assigned, they will show on the right column under the **Unassigned ID** heading.

```
DLC CARD 1 CELL ASSIGNMENT

Num      Cell ID      Scale      Unassigned ID
>  1     1D6BFF0F      1
  2     15D64531      1
  3     0B5B616F      1
  4     101BA5C1      1
  5     115DC621      2
  6     049AED9F      2
  7     0B2E2ECF      2
  8     0AF79DC1      2
  9     03573F3F      3
 10     043105FF      3
 11     120B5F6F      3
 12     090F1F4F      3

Use navigation keys to move selection
Press SPACE to configure selected item
Press 'U' to unassign selected item
```

DLC Card 1 Cell Assignment, Cont.

The right navigation key may be used to select the unassigned column. The left navigation key may be used to select the existing cell IDs. The up/down navigation keys may be used to select a specific cell.

Assign Cell

Select the next cell to assign on the right column and press the **A** key to assign it to the next unassigned cell (cell ID 00000000). The ID will then appear on the assigned list on the left.

```
DLC CARD 1 CELL ASSIGNMENT

Num    Cell ID    Scale    >    Unassigned ID
  1    1D6BFF0F    1
  2    15D64531    1
  3    0B5B616F    1
  4    101BA5C1    1
  5    115DC621    2
  6    049AED9F    2
  7    0B2E2ECF    2
  8    0AF79DC1    2
  9    03573F3F    3
 10    00000000    3
 11    00000000    3
 12    00000000    3

Unassigned ID
  1    043105FF
  2    120B5F6F
  3    090F1F4F

Use navigation keys to move selection
Press 'A' to assign selected item to
first available cell number
```

DLC Card 1 Cell Assignment, Cont.

Cell IDs may also be entered manually and the scale to associate with the cell by selecting an item in the left column pressing the **SPACE** key.

DLC CARD 1 CELL ASSIGNMENT			
Num	Cell ID	Scale	Unassigned ID
1	1D6BFF0F	1	> 1 120B5F6F
2	15D64531	1	2 090F1F4F
3	0B5B616F	1	
4	101BA5C1	1	
5	115DC621	2	
6	049AED9F	2	
7	0B2E2ECF	2	
8	0AF79DC1	2	
9	03573F3F	3	
10	043105FF	3	
11	00000000	3	
12	00000000	3	

Use navigation keys to move selection
Press 'A' to assign selected item to
first available cell number

DLC Card 1 Cell Assignment, Cont.

Type the **Cell ID** if it is to be changed, press the down navigation key to select the **Scale:** prompt, and then enter the scale number.

```
DLC CARD 1 CELL ASSIGNMENT

Num      Cell ID      Scale      Unassigned ID
  1      1D6BFF0F      1          1  120B5F6F
  2      15D64531      1          2  090F1F4F
  3      0B5B616F      1
  4      101BA5C1      1
  5      115DC621      2
  6      049AED9F      2
  7      0B2E2ECF      2
  8      0AF79DC1      2
  9      03573F3F      3
 10      043105FF      3
> 11      00000000      3
 12      00000000      3

Cell ID: 120B5F6F
Scale:   3
```

When finished press and release the **SHIFT** key, then press the **ESC/←** key.

The display will return to the Setup Scale Number screen.



NOTE: If the DLC configuration changes have changed the number of scales the 825D, power should be turned off, and after a brief delay turn the power back on.

Select a scale to configure or calibrate:

The display will change to show the **Scale 1 - Calibration Options** screen.



IMPORTANT! It is very important that the dead load of the weighbridge is evenly distributed between the pair of cells in a section, before calibrating the scale. Refer to the **Balancing Weighbridge Dead Load** section on page 107 of this manual for more instructions.

Smart Calibration

2. Smart Calibration

With the **Scale 1 - Calibration Options** screen displayed, press the **2** key or use the Navigation Keys to select (highlight) **2. Smart Calibration**, and then press the **ENTER** key.

Scale 1 - Calibration Options

Press:

1. Parameters
2. Smart Calibration
3. Zero Calibration
4. Trim Load Cells
5. Span Adjust
6. DLC Diagnostics

Hardware calibration enabled

The display will change to show the **Scale 1 - Smart Calibration** screen.

Smart Calibration, Cont.

With the **Scale 1 - Smart Calibration** screen displayed, enter the weight value of the test weight to be used.

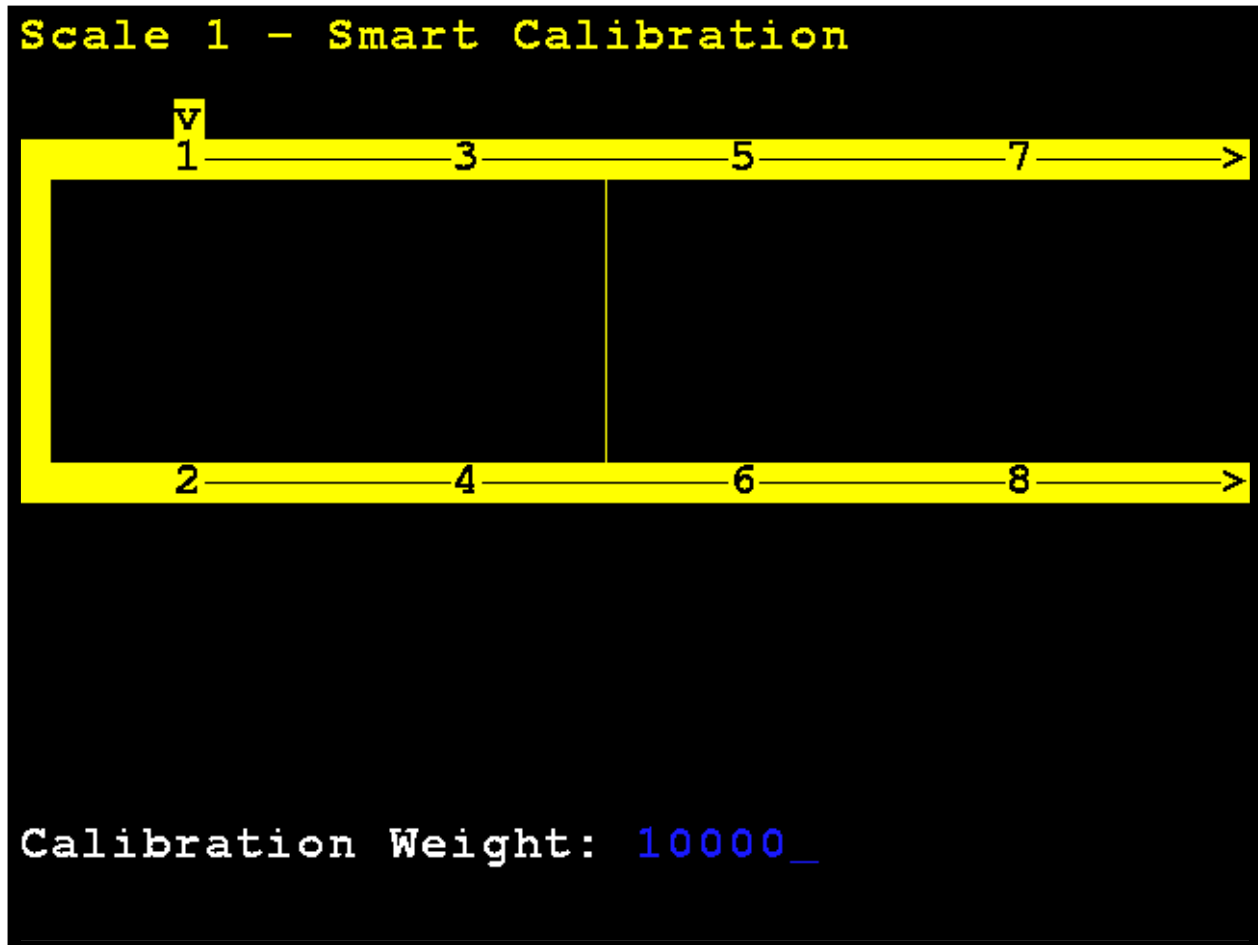

Smart Calibration, Cont.

With an empty scale, press **ENTER**. This will capture the calibrated dead load weight of the scale.

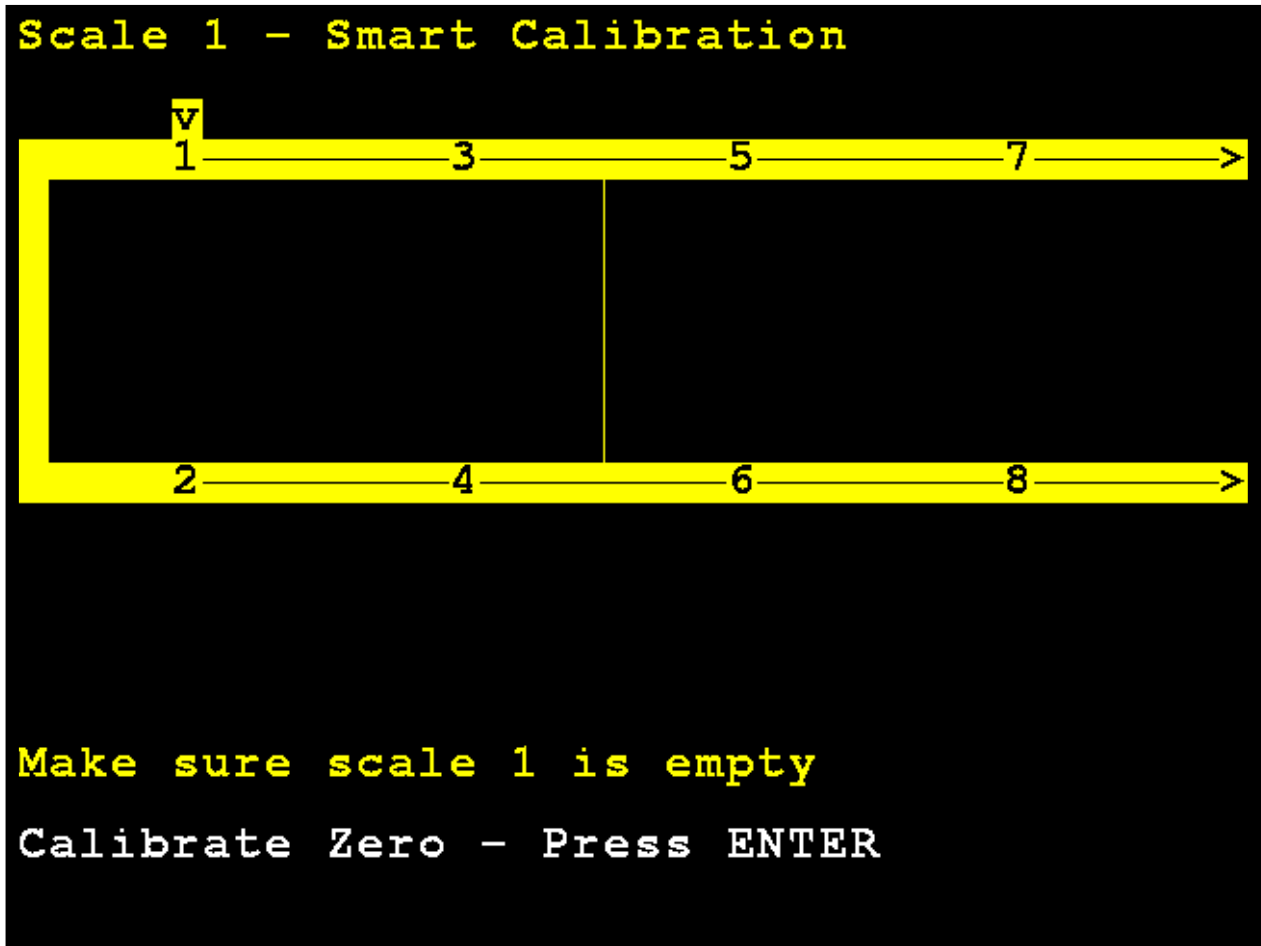

Smart Calibration, Cont.

The 825D display will change to show that it is calibrating.

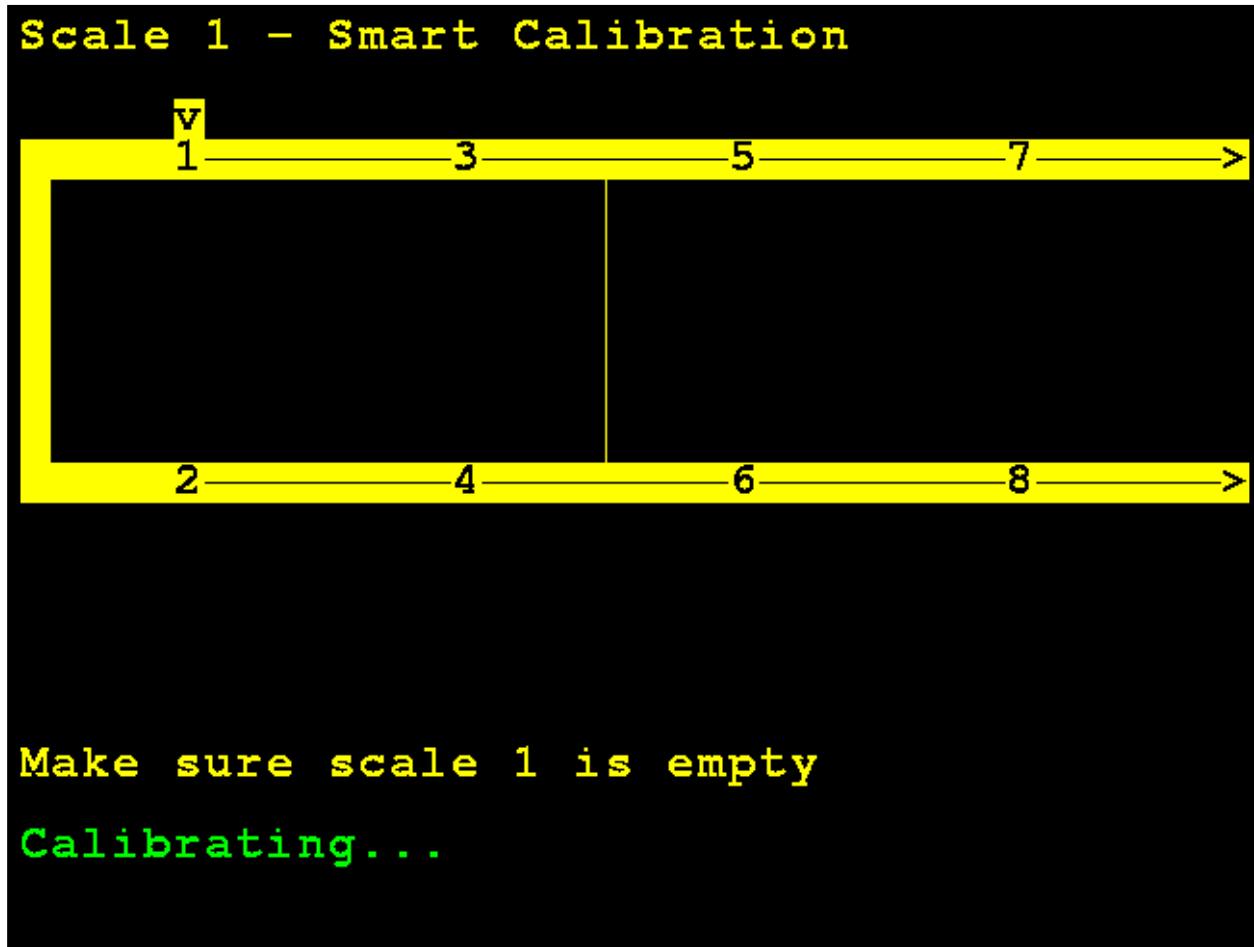

Smart Calibration, Cont.

Center the weight over load cell 1, and press **ENTER**.

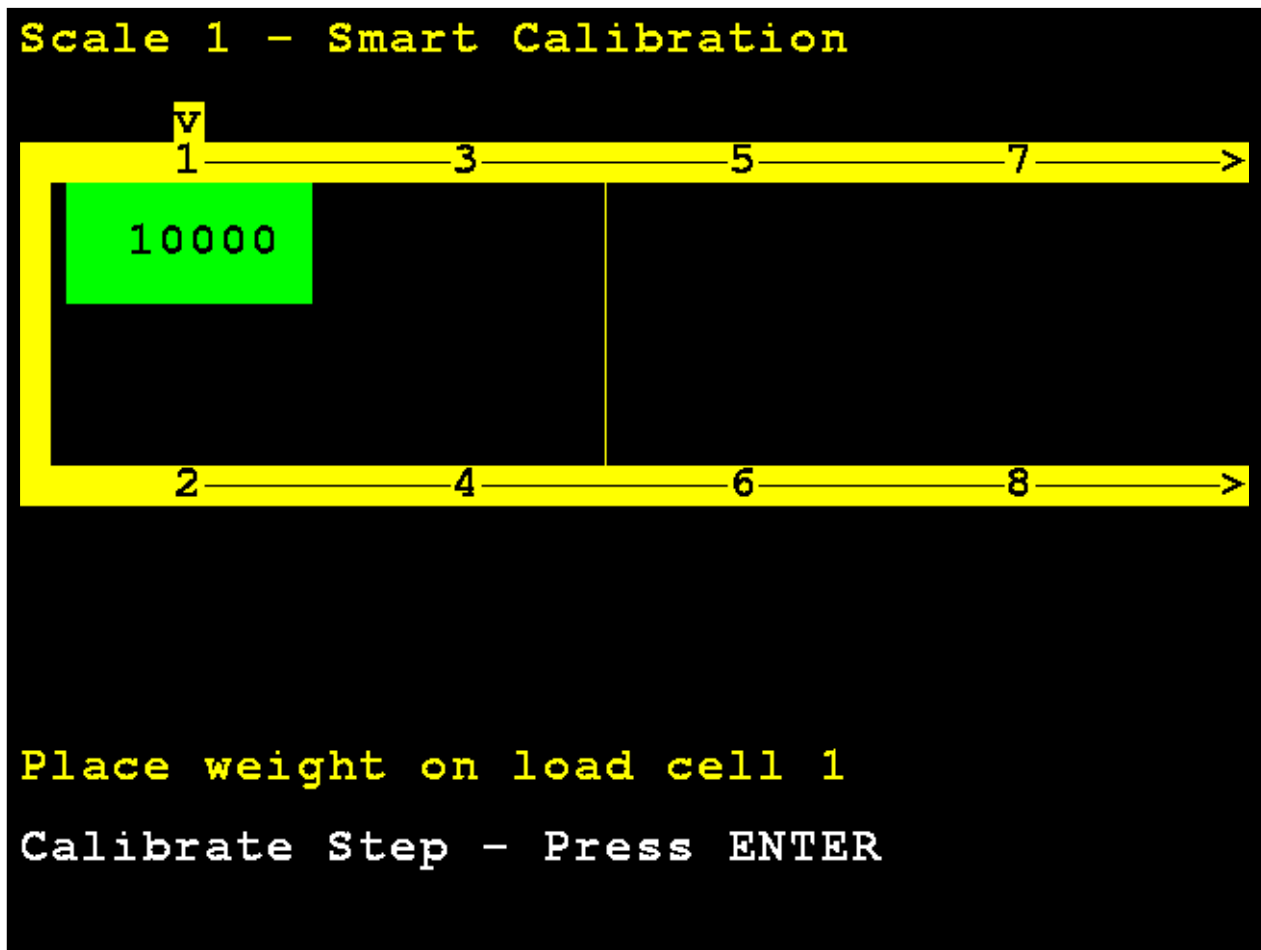

Smart Calibration, Cont.

The 825D display will change to show that it is calibrating the weight on load cell 1.

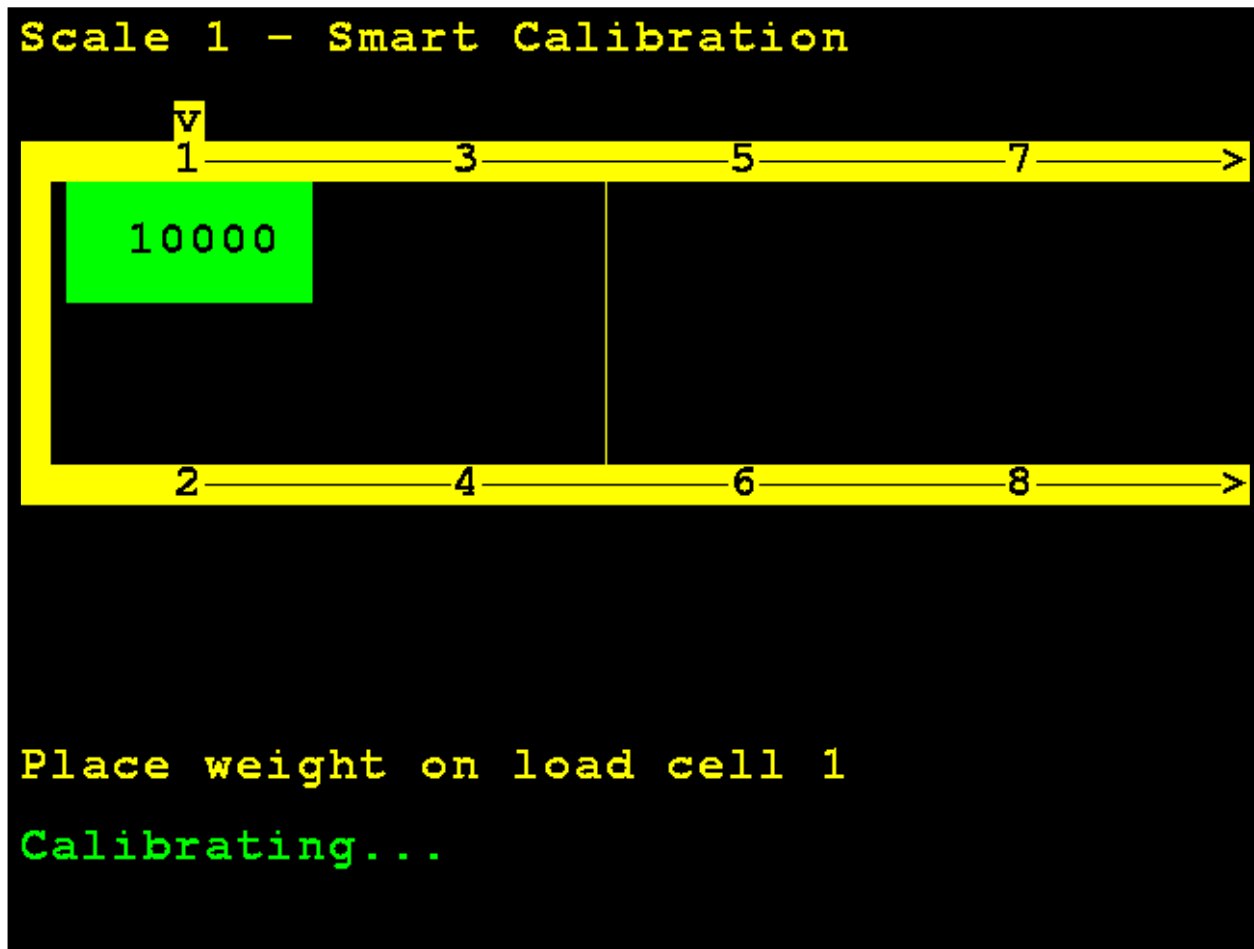

Smart Calibration, Cont.

Move the test weight and center it over load cell 2, and press **ENTER**.

The 825D display will change to show that it is calibrating the weight on load cell 2.

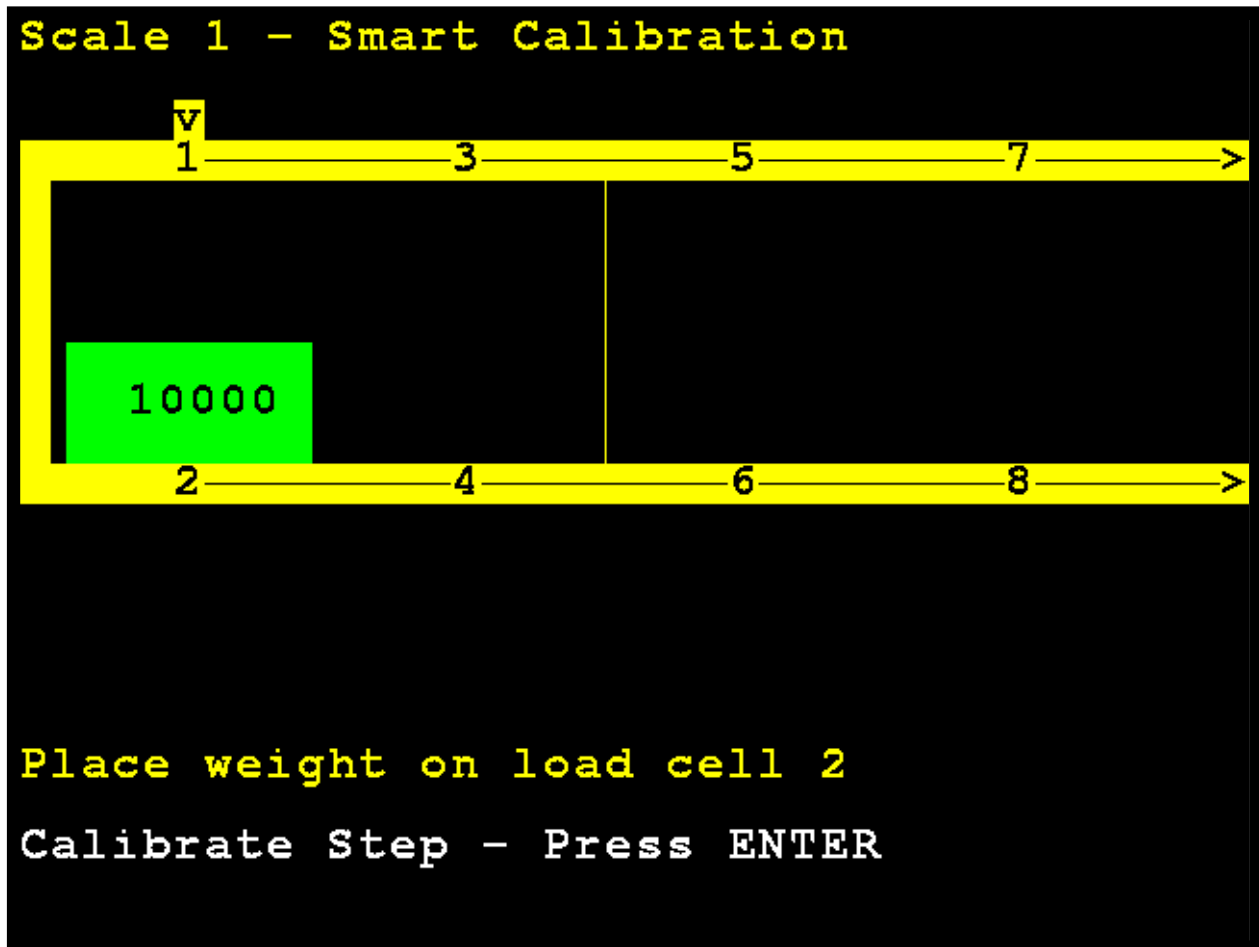

Smart Calibration, Cont.

Move the test weight and center it over load cell 3, and press **ENTER**.

The 825D display will change to show that it is calibrating the weight on load cell 3.

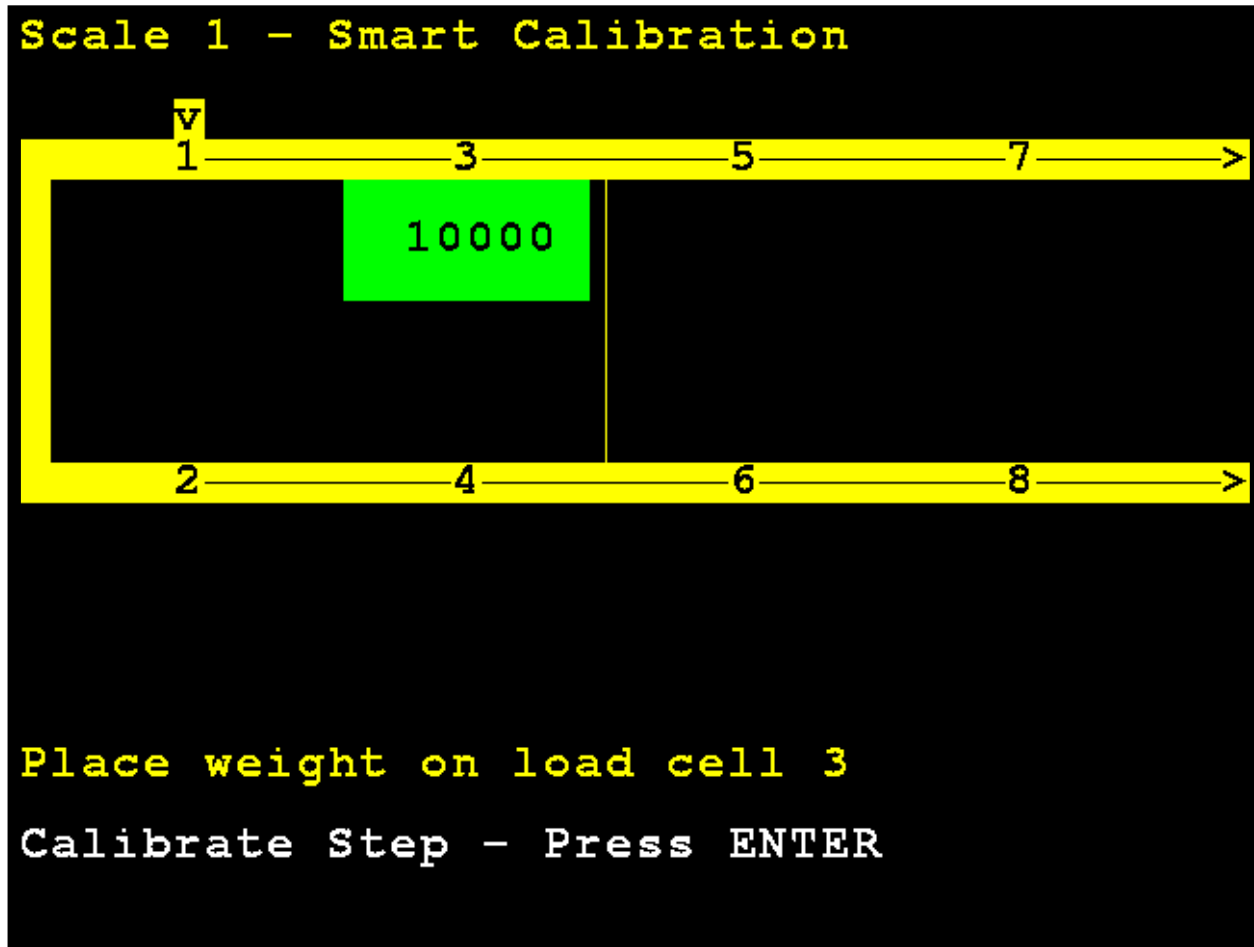

Smart Calibration, Cont.

Move the test weight and center it over load cell 4, and press **ENTER**.

The 825D display will change to show that it is calibrating the weight on the load cell.

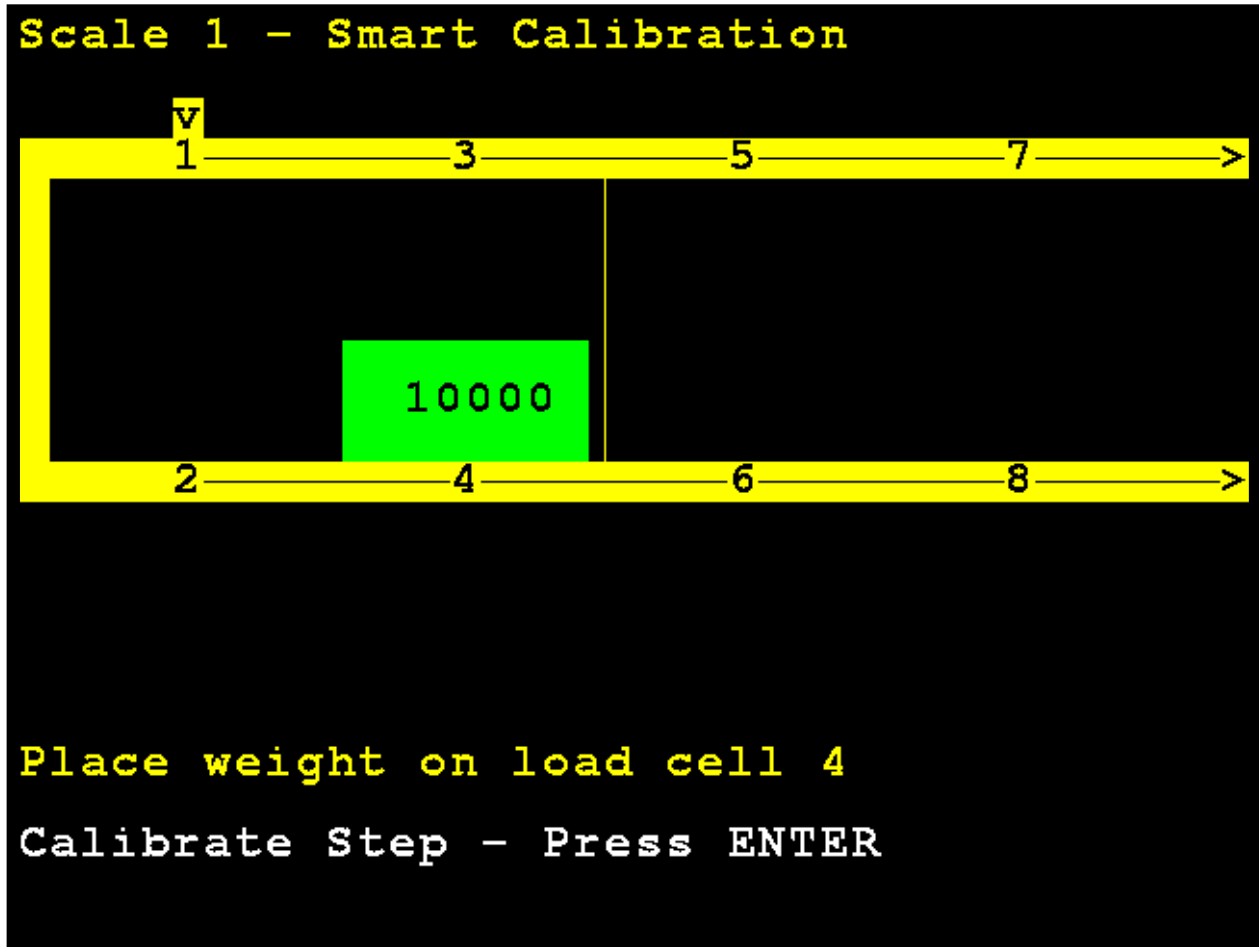

If more than four cells and the number of cells is even a number (such as for an eight-cell scale), the calibration pattern will be the odd number cells, then the even number cells *in reverse* to facilitate easy weight cart movement:

1, 3, 5, 7, 8, 6, 4, 2

Otherwise, the calibration pattern will be sequential:

1, 2, 3, 4, 5, 6, 7, 8

Zero Calibration

3. Zero Calibration

With the **Scale 1 - Calibration Options** screen displayed, press the **3** key, or use the Navigation Keys to select (highlight) **3. Zero Calibration**, and then press the **ENTER** key.

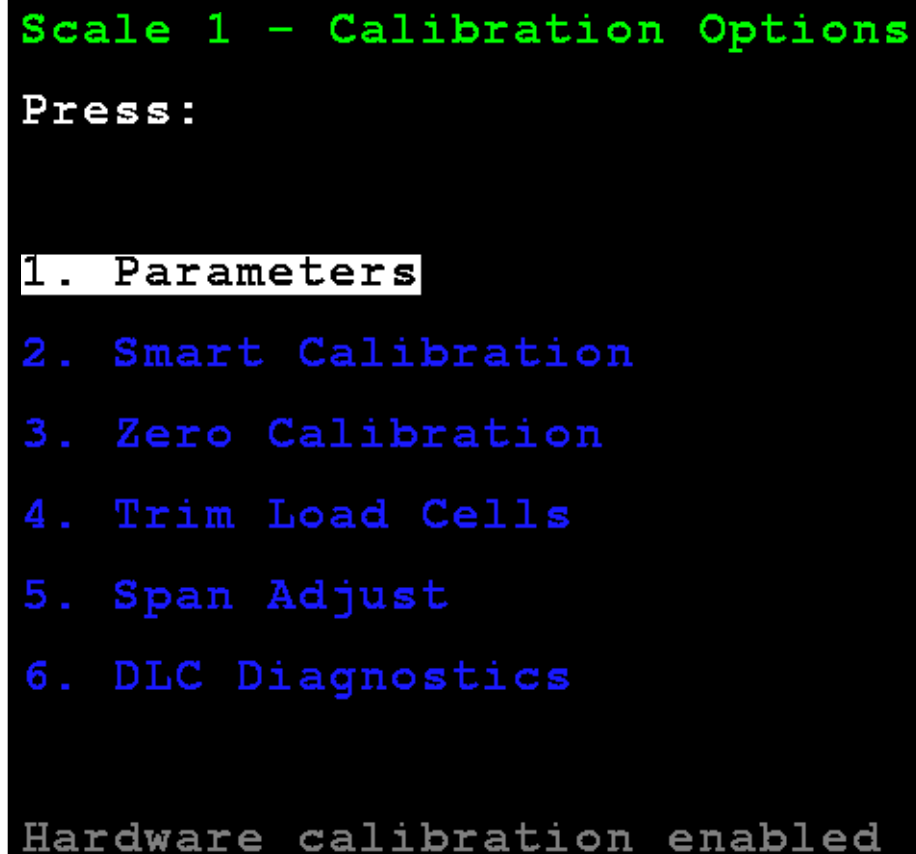

```
Scale 1 - Calibration Options
Press:
1. Parameters
2. Smart Calibration
3. Zero Calibration
4. Trim Load Cells
5. Span Adjust
6. DLC Diagnostics

Hardware calibration enabled
```

The display will change to show the **Scale 1 - Zero Calibration** screen.

Zero Calibration, Cont.

With an empty scale, press **ENTER**. Zero Calibration does not affect the trimming of the cells or affect span; it simply sets the dead load weight of the scale.

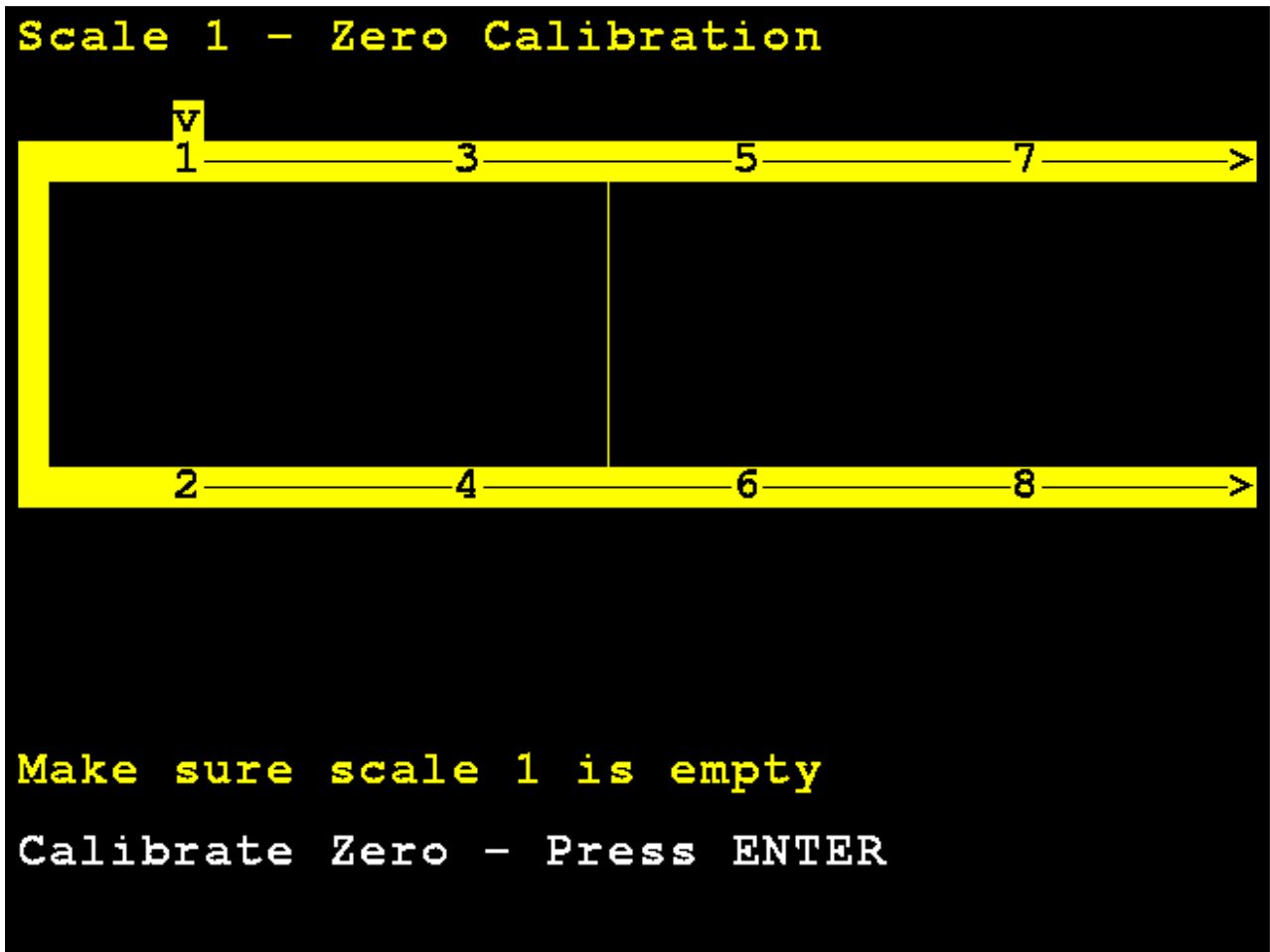

Zero Calibration, Cont.

The 825D display will change to show that it is calibrating zero.

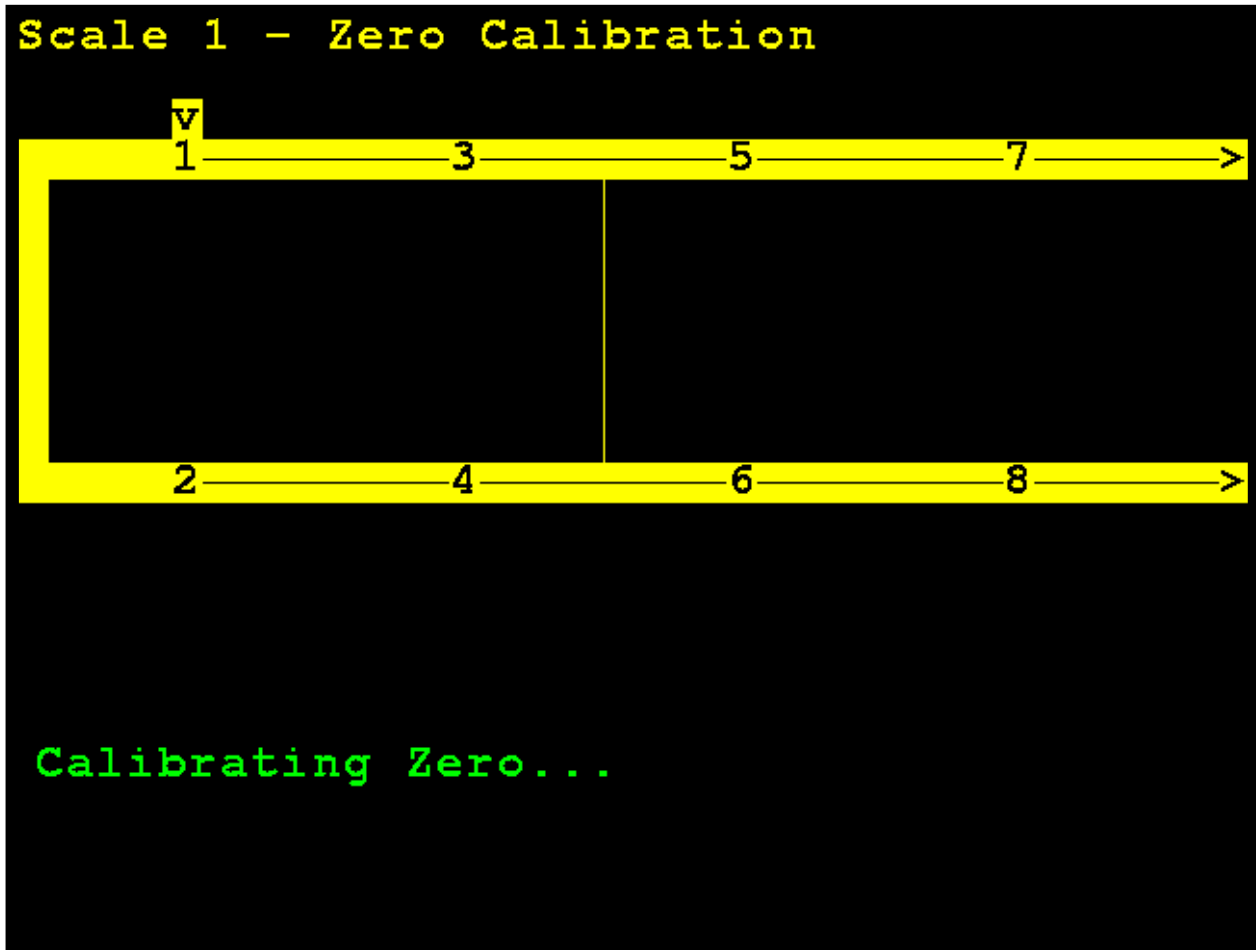

Trim Cells

4. Trim Load Cells

With the **Scale 1 - Calibration Options** screen displayed, press the **3** key, or use the Navigation Keys to select (highlight) **4. Trim Load Cells**, and then press the **ENTER** key.

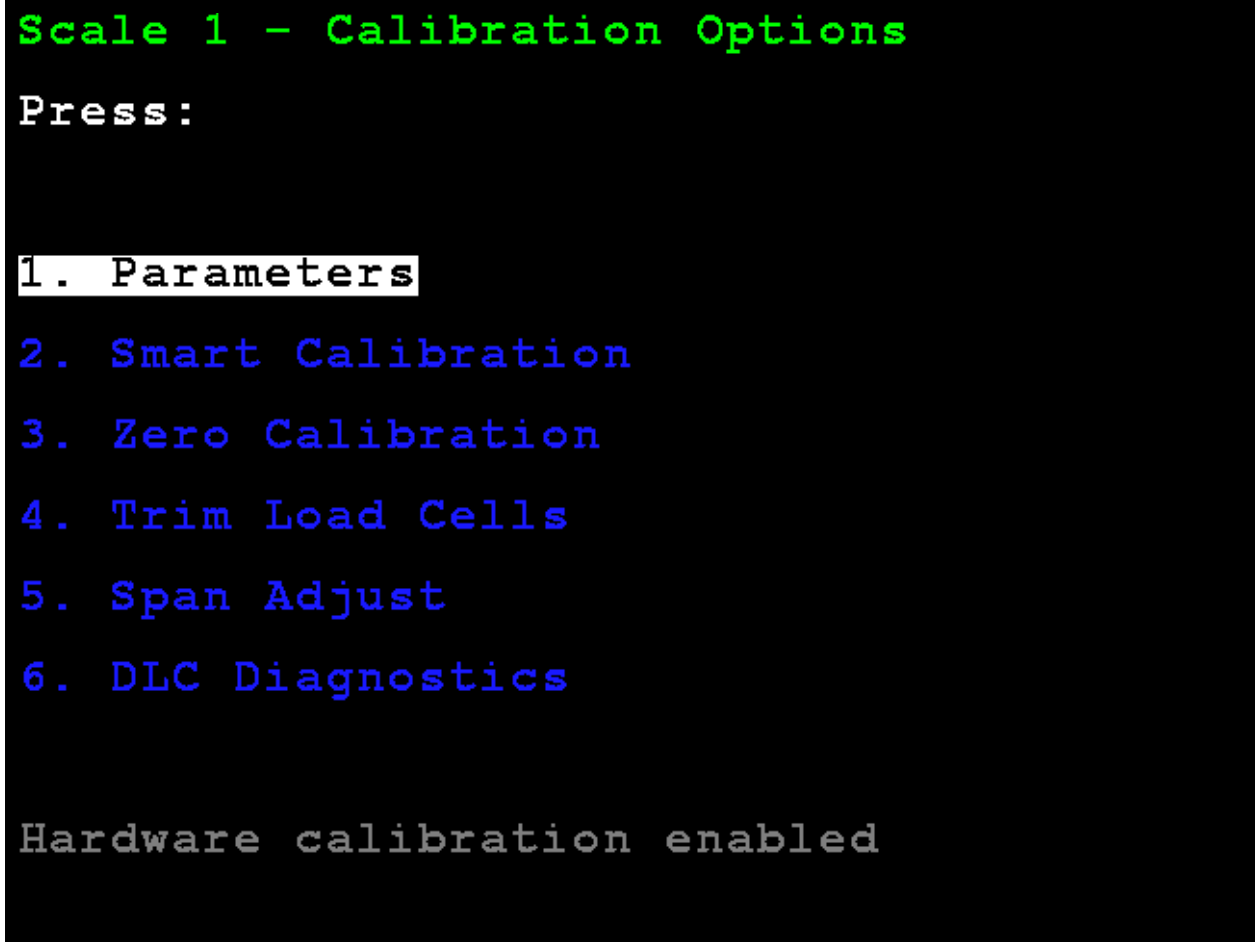

The display will change to show the **Scale 1 - Trim Cells** screen.

Trim Cells, Cont.

Section Trim Mode

Individual cells or a section (pairs of cells) may be trimmed. This requires a test load weight.

M)ode – Press the **M** key to toggle between Section or Single Cell trim. *Default is Section.*

Use the Navigation Keys to select (highlight) the section to trim.

With the desired section selected, enter the Trim Value, and press the **ENTER** key to set the weight to adjust trim.

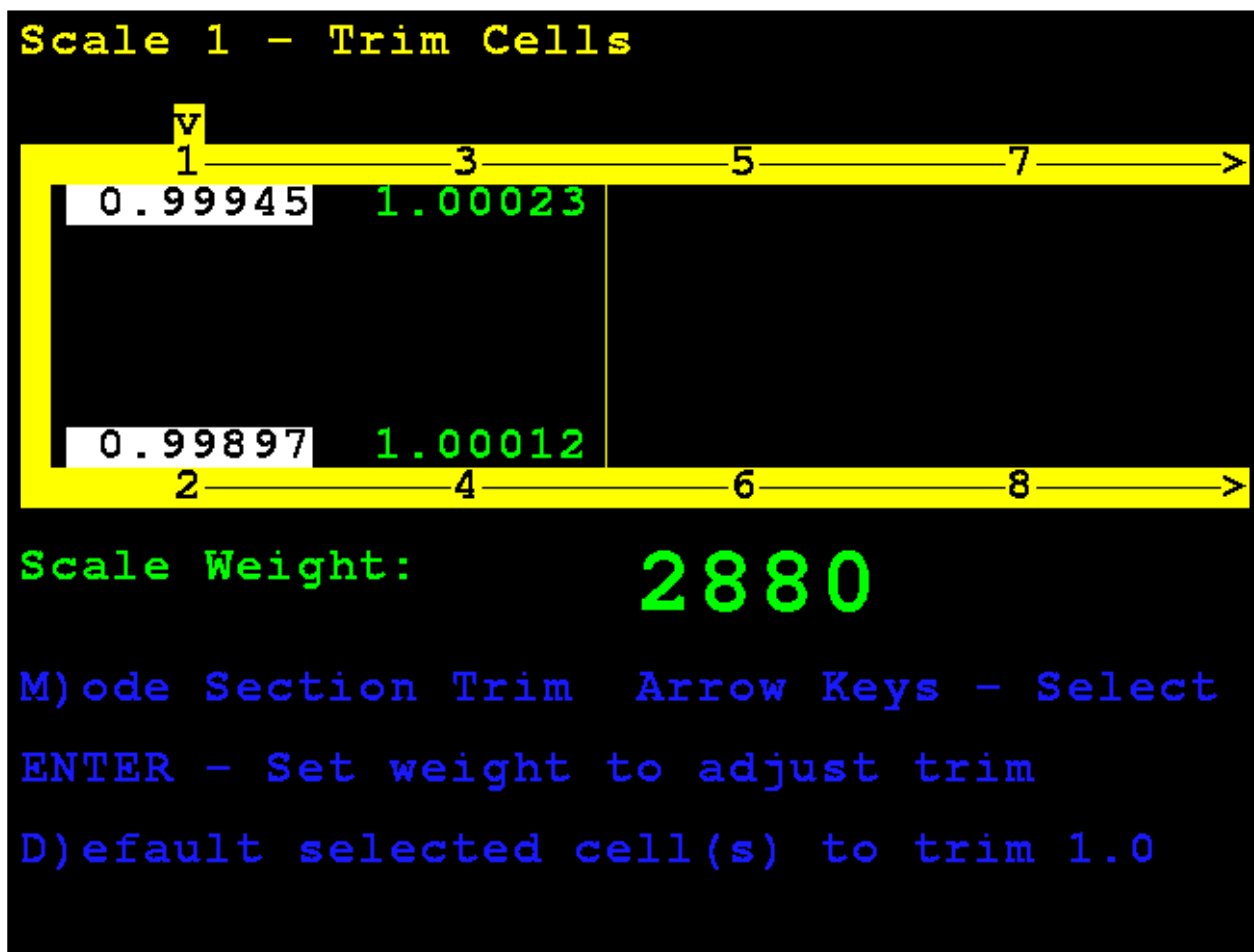

Trim Cells, Cont.

Single Cell Mode

Press the **M** key to select Single Cell trim.

Use the Navigation Keys to select (highlight) the cell to trim.

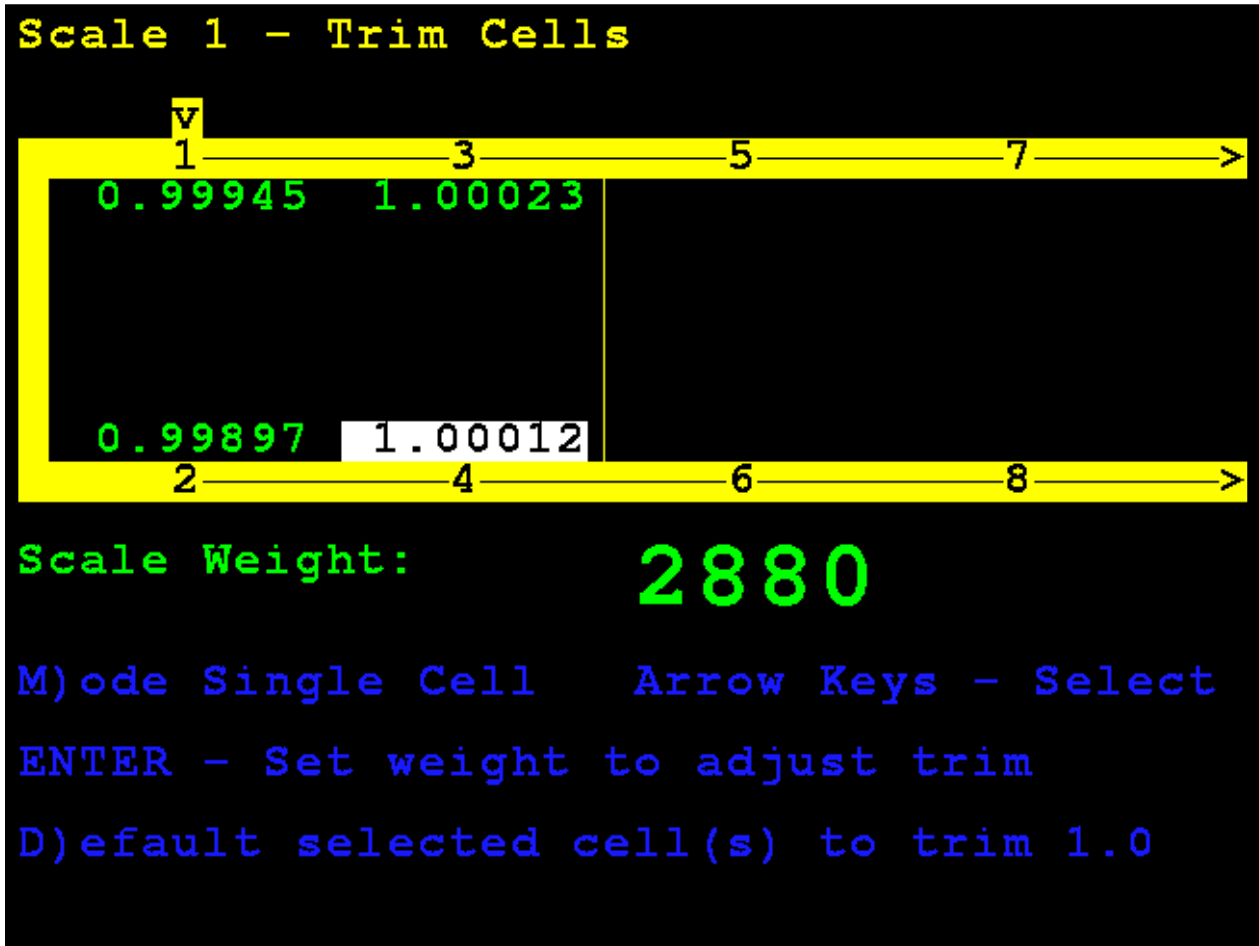

Trim Cells, Cont.

Single Cell Mode, Cont.

With the desired cell selected, enter the Trim Value, and press the **ENTER** key to set the weight to adjust trim.

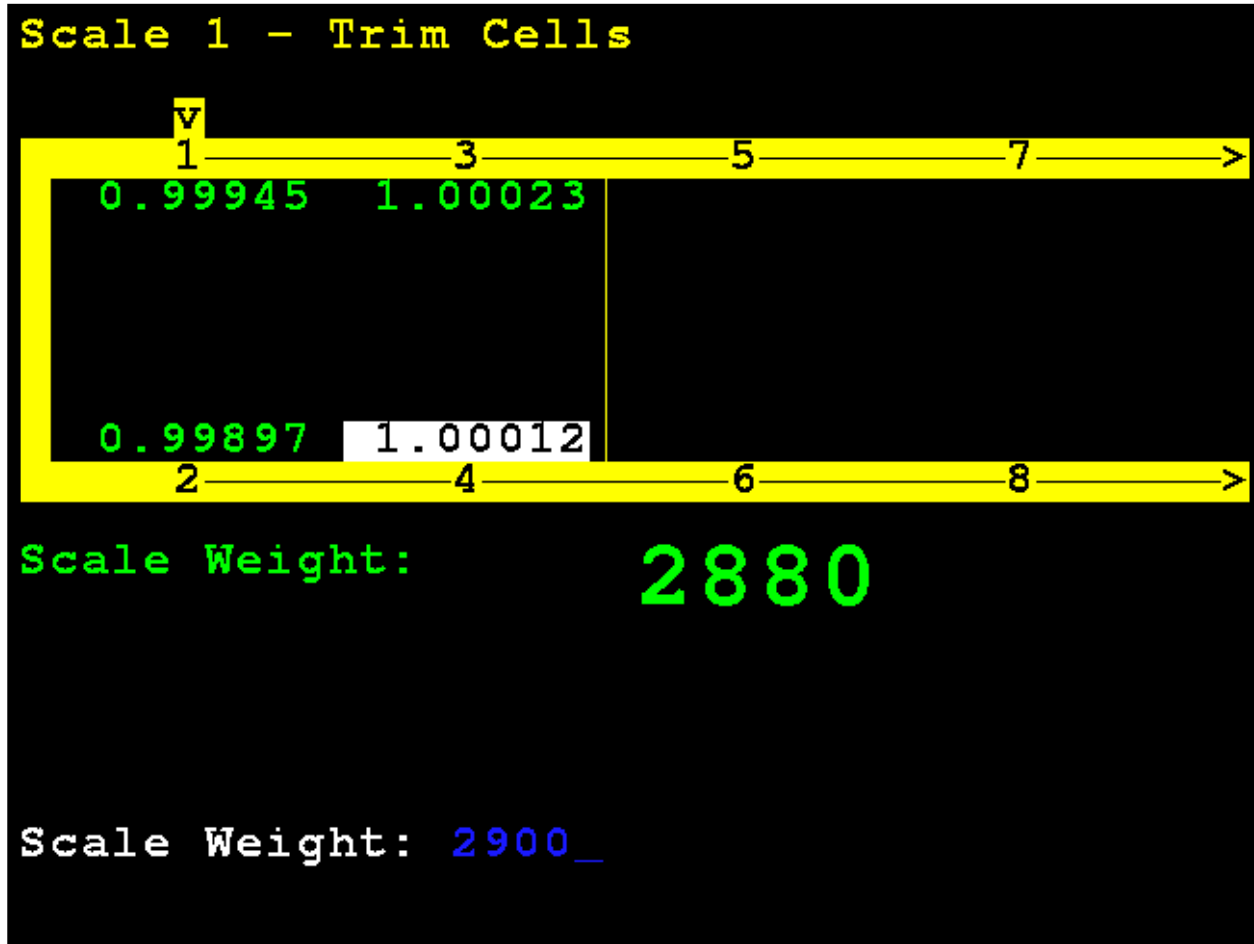

Trim Cells, Cont.

Single Cell Mode, Cont.

The 825D will automatically trim the cell to match the entered weight.

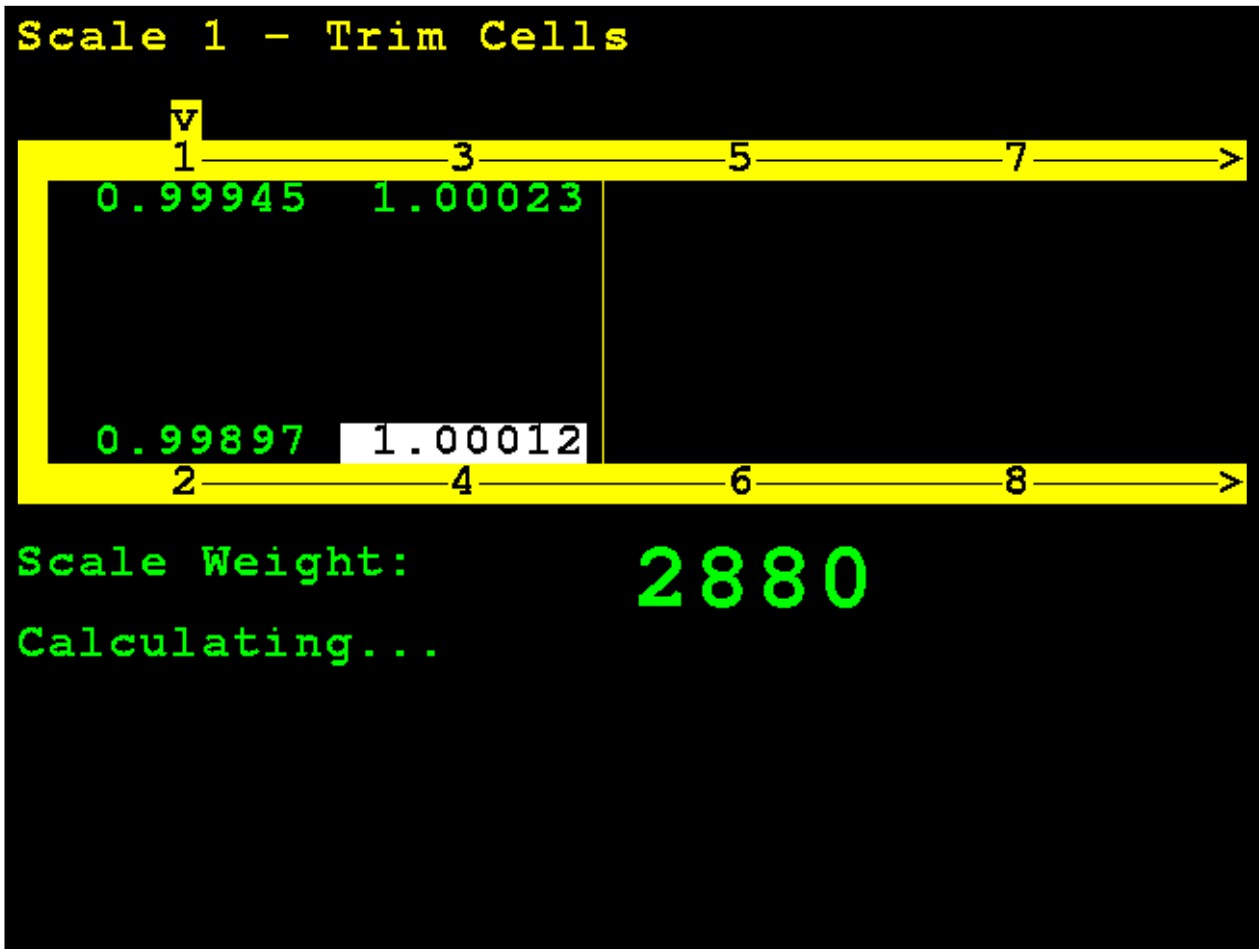

Trim Cells, Cont.

Single Cell Mode, Cont.

NOTE: If in the Single Cell mode, manually enter a trim value by pressing the **FUNCT** key, then press the (•) period key. This can be used to enter a slight adjustment, such as change 0.98411 to 0.98421.

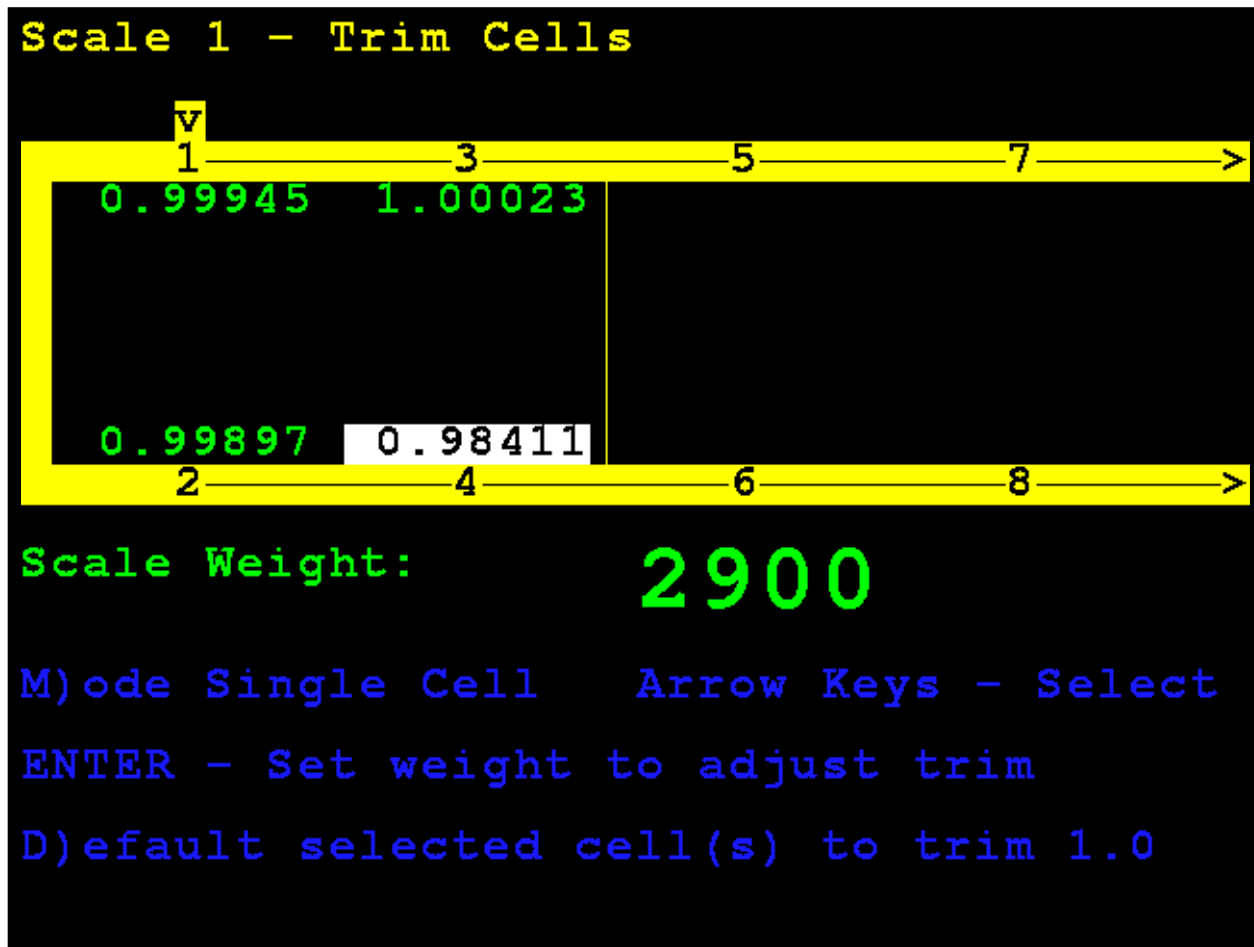

When finished, press, and release the **SHIFT** key, then press the **ESC/←** key to exit.

Span Adjust

5. Span Adjust

With the **Scale 1 - Calibration Options** screen displayed, press the **3** keys, or use the Navigation Keys to select (highlight) **5. Span Adjust**, and then press the **ENTER** key.

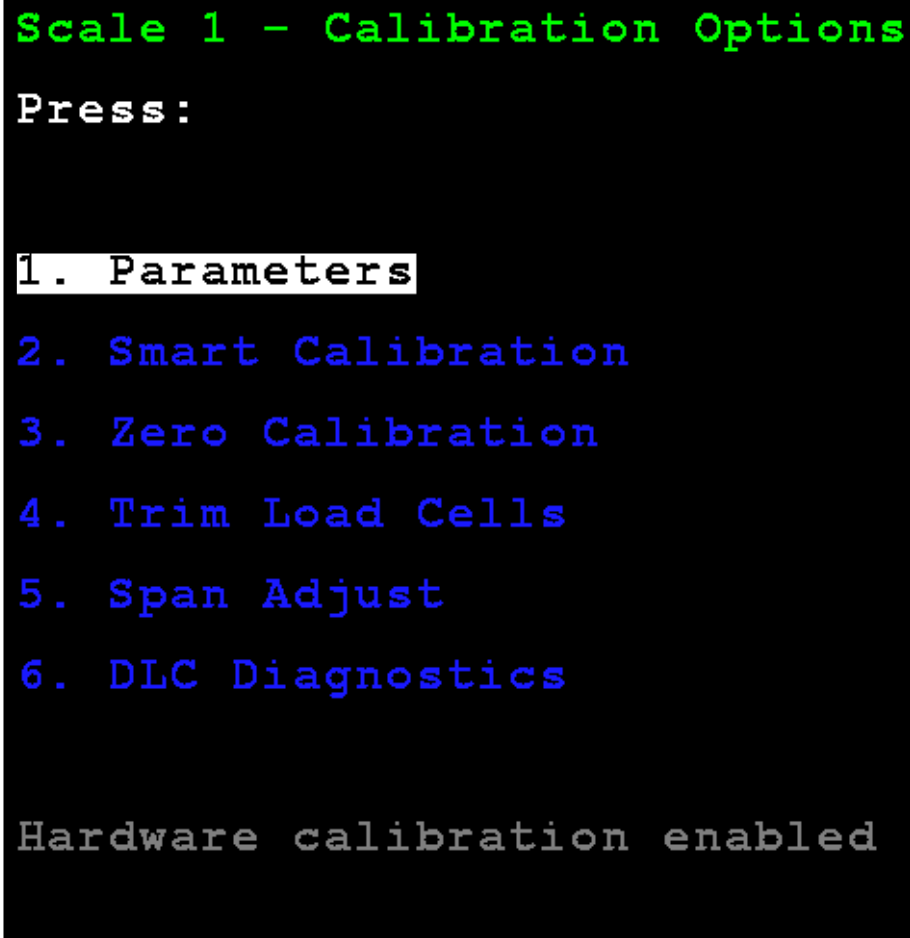

The display will change to show the **Scale 1 - Span Adjust** screen.

Span Adjust

Span adjust allows you to tweak the span of the entire scale at once.

The 825D will display the current live scale weight.

Place the test weight at any location on the scale.

Enter the value of the test weight and press the **ENTER** key.

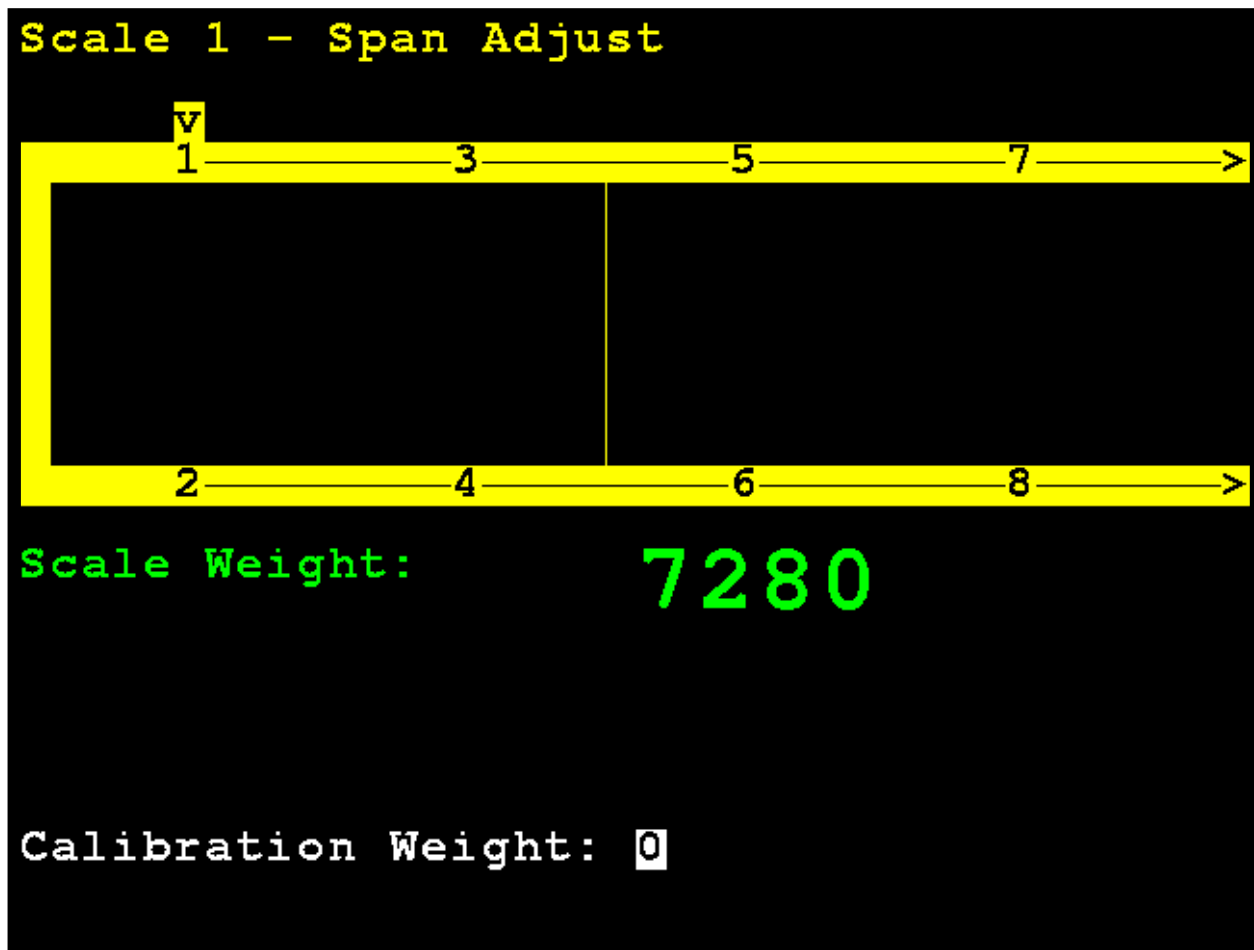

Span Adjust

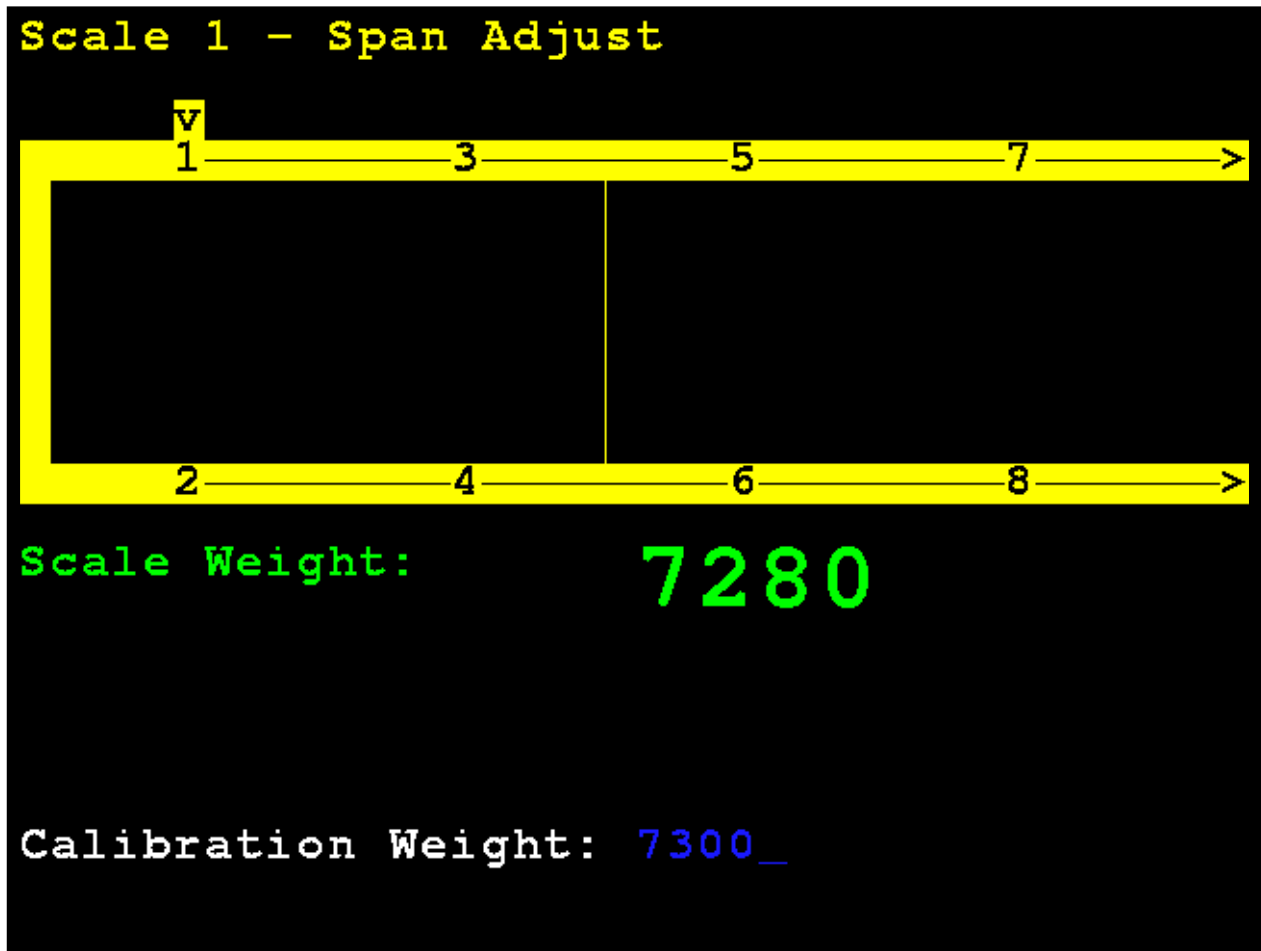

After a brief delay, the span will be adjusted (trim will be adjusted for all cells of the scale) and the 825D display will return to the **Scale 1 - Calibration Options** screen.

WEIGHBRIDGE DEAD LOAD

Balancing the Weighbridge Dead Load

Before calibration, it is very important that the dead load of the weighbridge is evenly distributed between the pair of cells in a section.

1. Begin by powering up the indicator and proceeding to the Diagnostics Menu to the LOADCELL WEIGHTS screen on the 225D or the LIVE LOAD CELL WEIGHTS on the 825D.
2. Each pair of load cells should be carrying an equal dead load of plus (+) or minus (-) 10 percent.
3. If a cell in a section has an output of less than 20 percent of the cell carrying the most load, jack the weighbridge up, loosen the load cell mounting bolt as well as the load cell pivot plate retaining bolt, and place a factory-supplied shim (0330-0148-08, 7 GA. LOAD CELL SHIM) or (0330-0149-08, 10 GA. LOAD CELL SHIM) between the load cell pivot plate, and the weighbridge load cell block.

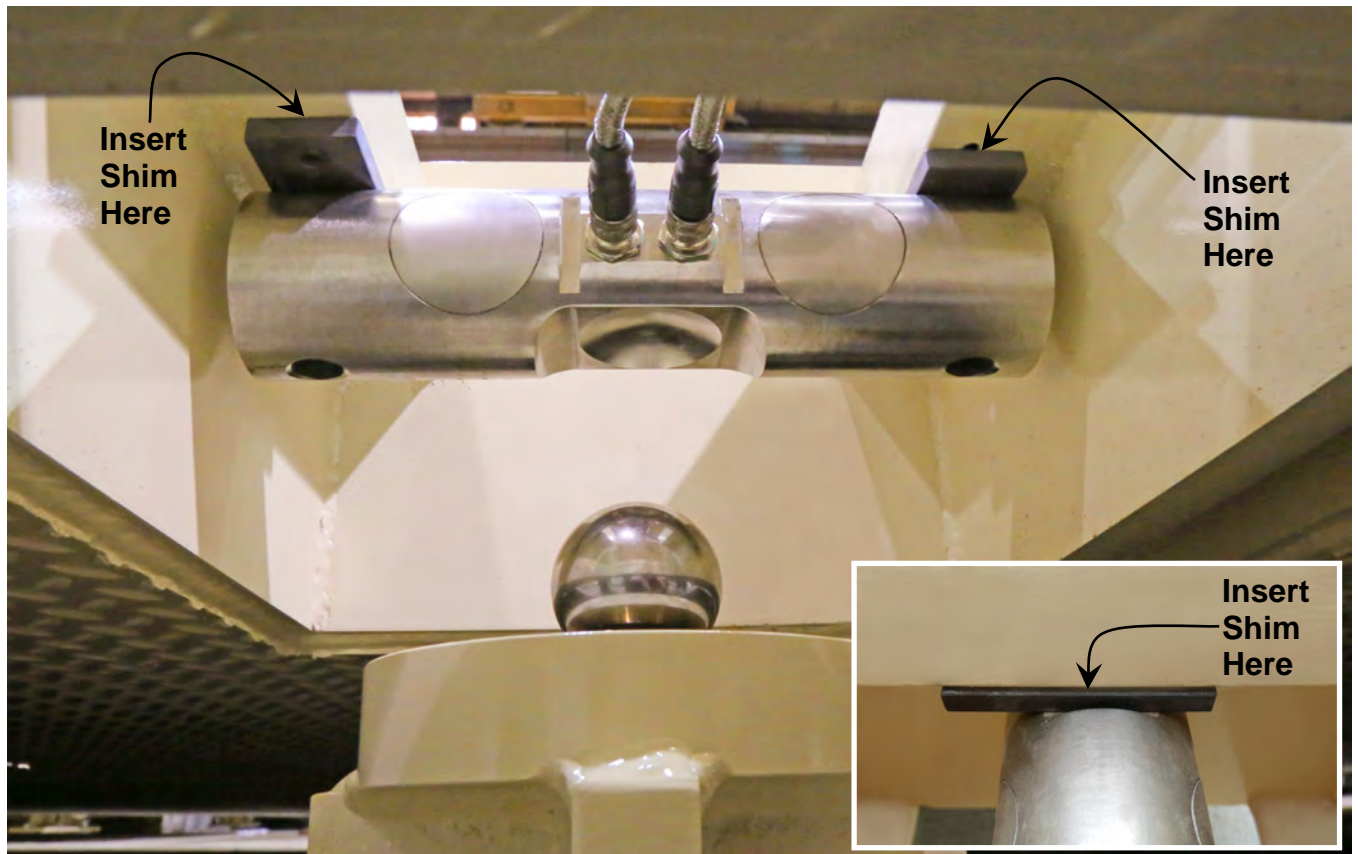

DIGITAL SCALE DIAGNOSTICS

225D Digital Scale Diagnostics

There are four main components to the 225D Digital Scale Diagnostics:

- On Screen Diagnostics – Critical errors that alert the operator from the main screen of setup issues or hardware problems.
- Diagnostic Menu – A set of diagnostic tools that give a technician more information about each load cell.
- iSite – Web-based repository for historical load cell data that will be tracked for slow degradation of load cell integrity (for example a single load cell that is drifting away from zero). iSite will also receive all the hardware errors found by the indicator.
- Hardware Diagnostics – LEDs on the 225DLC Controller (Digital Scale) Card alert technicians of communications status.

On Screen Diagnostics

The following messages will be shown to the operator on the main weight screen in real-time when an error happens.

COMMUNICATION ERROR BETWEEN INDICATOR AND SCALE

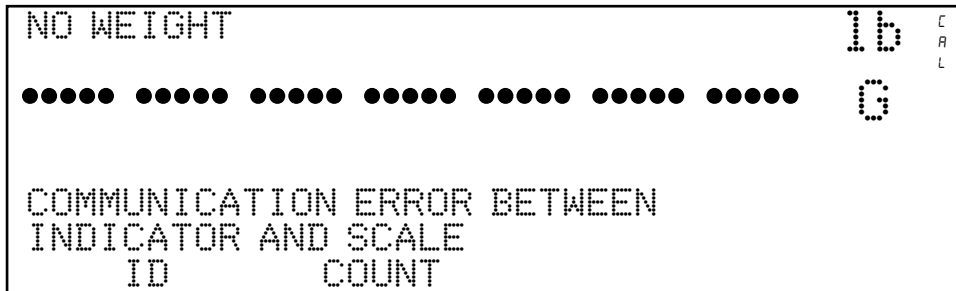

Probable Cause	Items to Check
The homerun cable is damaged or disconnected.	<ul style="list-style-type: none"> • Check that cable is connected correctly. • Check cable for damage. • Use caution on the amount of insulation stripped for the connector. Center wires could short. Must be shorter than the center connector. • Check connector for random strands of wire. • Verify that connector is clear of debris

COMMUNICATION ERROR BETWEEN LOAD CELLS X AND Y

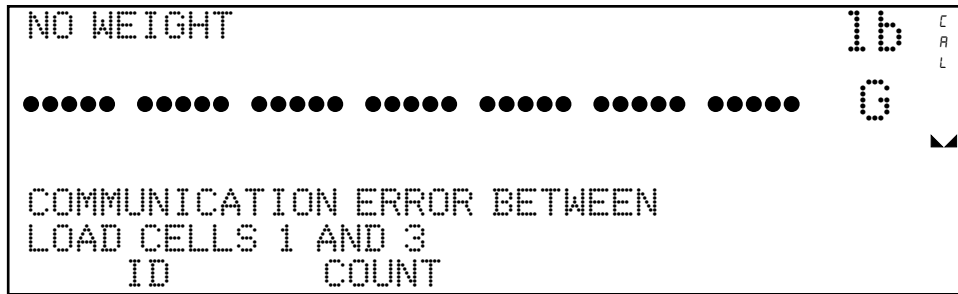

Probable Cause	Items to Check
There is a loss of communication between load cells.	<ul style="list-style-type: none"> • Check that cable is connected correctly. • Check cable for damage. • Verify that connector is clear of debris. • Check load cell COM ports on both load cells.

LOAD CELL X, Y, Z NOT RESPONDING

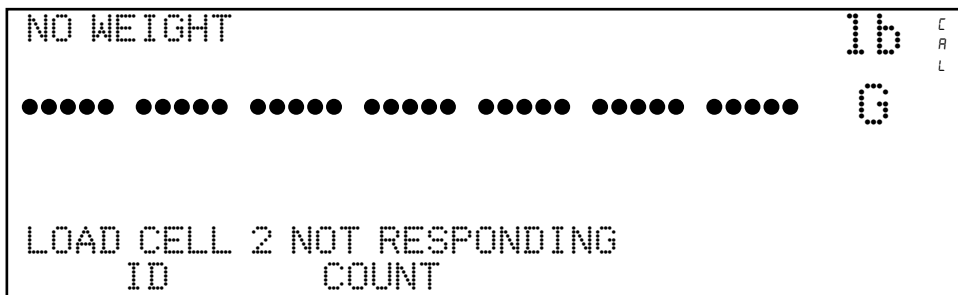

Probable Cause	Items to Check
The 225D cannot detect the exact communication problem with the unresponsive load cell.	<ul style="list-style-type: none"> • Check that cable is connected correctly. • Check cable for damage. • Verify that connector is clear of debris. • Potentially dead load cell.

LOAD CELL X DAMAGED

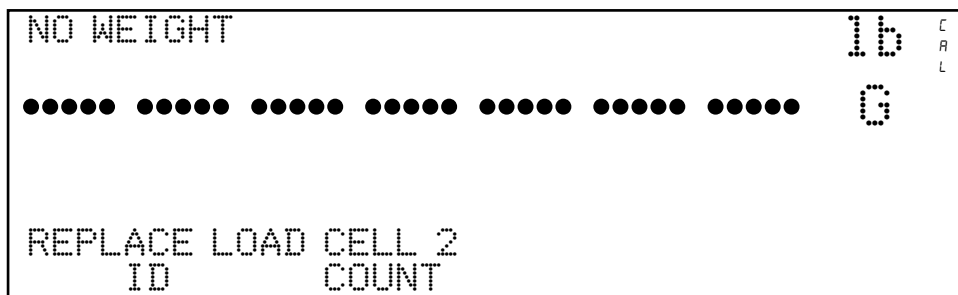

Probable Cause	Items to Check
There is irreparable internal damage to the load cell.	Replace load cell.

LOAD CELL X HAS BEEN REPLACED

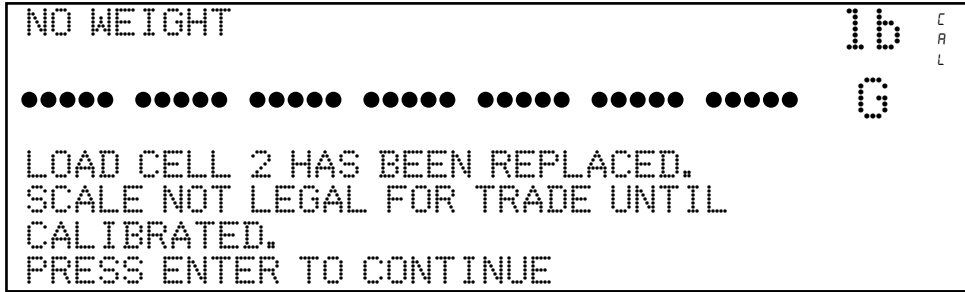

Probable Cause	Items to Check
A load cell has been replaced.	Replaced load cells are automatically detected as long as only one load cell was replaced. Once a load cell has been replaced, the 225D will auto-detect the new load cell and display the message that the scale is not Legal-For-Trade and will need to be calibrated.

MORE LOAD CELLS THAN EXPECTED

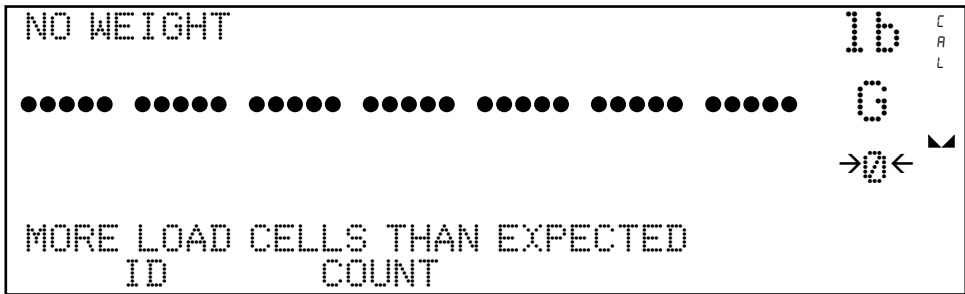

Probable Cause	Items to Check
There are more load cells than expected connected to the 225D. For example, the number of load cells in the indicator is set to 8, but the controller detects there are actually 12 load cells.	Confirm and configure the number of load cells the scale should have.

LOAD CELL ID 8F07E8F HAS NO ADDRESS

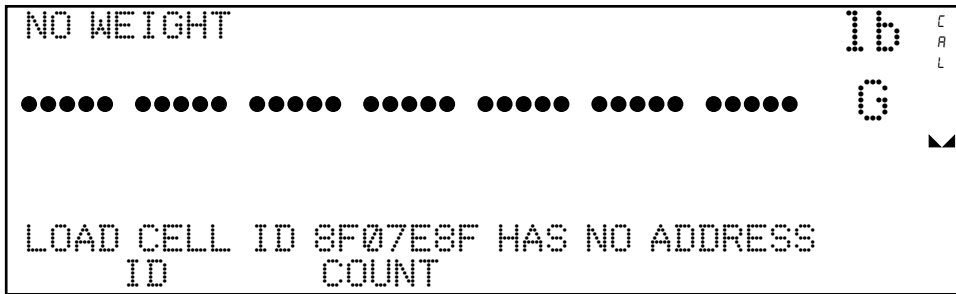

Probable Cause	Items to Check
A load cell is responding but it is not addressed in the system.	Go to the addressing menu and assign the load cell ID to an address.

LOAD CELL ADDRESS 1 NOT ASSIGNED TO SCALE

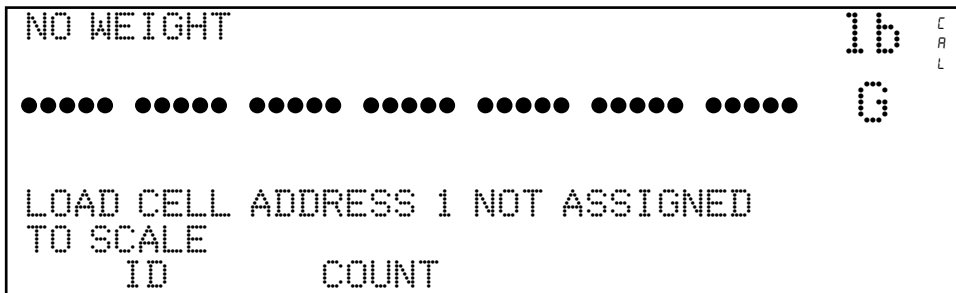

Probable Cause	Items to Check
A load cell has not been assigned to a scale.	Go to the addressing menu and assign a scale to the load cell.

LOW VOLTAGE DETECTED ON LOAD CELL X, Y, Z

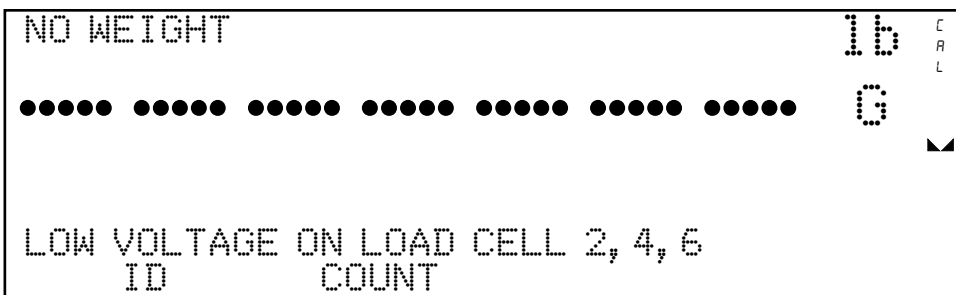

Probable Cause	Items to Check
Low power on a load cell. Load cells at the end of the CAN daisy-chain are most susceptible to low voltage errors because of voltage drop along the cable.	<ul style="list-style-type: none"> • Too many load cells on the chain. • Check that cable is connected correctly. • Check cable for damage. • Verify that connector is clear of debris • Check 225D indicator power supply.

DIGITAL SCALE BOARD NOT DETECTED

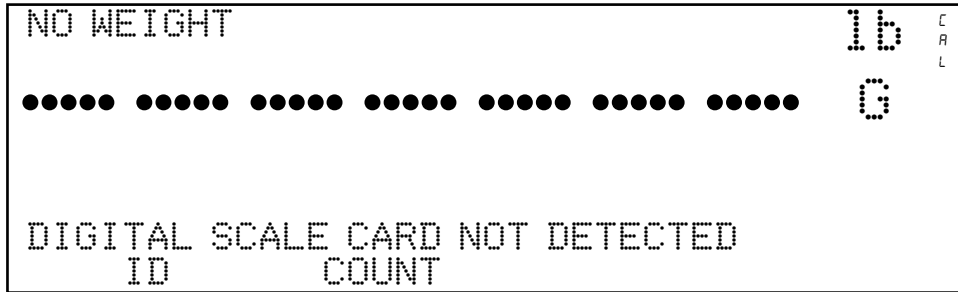

Probable Cause	Items to Check
<p>The 225D cannot communicate with the option card or the option card is not responding.</p>	<ul style="list-style-type: none"> • Check that the card is seated properly and fastened correctly. • Check that card is seated on the correct row of pins. • Potential of a failed card if occurs after installation and in-service.

Diagnostic Menu

To enter the diagnostic menu press **SHIFT + CELL_DIAG** soft key. All diagnostic information except software version updates once per second.

LIVE LOAD CELL WEIGHTS (*This can be zeroed as needed.*)

LOAD CELL WEIGHTS			
1.	225	6.	779
2.	104	7.	36
3.	-106	8.	50
4.	-120		
5.	639		
PREVIOUS		NEXT	
		EXIT	

MINIMUM AND MAXIMUM WEIGHTS (*This can be zeroed as needed.*)

MAXIMUM / MINIMUM WEIGHTS					
1.	0/	0	6.	0/	0
2.	0/	0	7.	0/	0
3.	0/	0	8.	0/	0
4.	0/	0			
5.	0/	0			
PREVIOUS		NEXT		EXIT	



Zeroing the LIVE LOAD CELL WEIGHTS and MINIMUM AND MAXIMUM WEIGHTS screens is only temporary while in diagnostics. It does not affect the scale weight working zero. If you exit diagnostics and return, the weights will have returned to the previous values.

DEADLOAD SHIFT

DEADLOAD SHIFT		* = CHECK LOAD CELL	
1.	-1	6	0
2.	2	7	2
3.	0	8	-1
4.	0		
5.	-3		
PREVIOUS		NEXT	
		EXIT	

This shows the live shift from the original calibrated deadload. An asterisk (*) indicates that the deadload shift has been exceeded. The scale must be empty for this to be valid.

SOFTWARE VERSION OF CELL

LOADCELL SOFTWARE VERSIONS			
1.	1.0.14	6.	1.0.14
2.	1.0.14	7.	1.0.14
3.	1.0.14	8.	1.0.14
4.	1.0.14		
5.	1.0.14		
PREVIOUS		NEXT	EXIT

NOTE: The controller's version number, in contrast, is displayed upon startup of the 225D indicator.

LOADCELL COMMUNICATION ERROR COUNTS

LOADCELL COMMUNICATION ERROR COUNTS			
1.	1	6.	0
2.	1	7.	0
3.	0	8.	0
4.	1		
5.	1		
PREVIOUS		NEXT	EXIT

DLC CARD COMMUNICATION ERROR COUNTS

DLC CARD COMMUNICATION ERROR COUNTS	
Overflow	0
Bus Off	0
CAN Err	0
PREVIOUS	
NEXT	
EXIT	

Overflow	This is the count of any missed messages from the DLC card buffer that were not kept up with. This should not happen unless too many cells are connected with too high of a sample rate.
Bus Off	This does not happen if you completely disconnect the home run cable but does count up if V+ or V- is disconnected.
CAN Err	This counts for any of the following errors:

WEIGHT ERROR COUNTS

WEIGHT ERROR COUNTS			
1.	0	6.	0
2.	0	7.	0
3.	0	8.	0
4.	0		
5.	0		
PREVIOUS		NEXT	EXIT

LOAD CELL TEMPERATURES

LOAD CELL TEMPERATURES			
1.	-49.00	6.	-49.00
2.	-41.00	7.	-41.00
3.	-41.00	8.	-41.00
4.	-41.00		
5.	-41.00		
PREVIOUS		NEXT	EXIT

CELL POWER SUPPLY VOLTAGES

CELL POWER SUPPLY VOLTAGES *Approx.			
1.	14.355	6.	14.191
2.	13.950	7.	14.530
3.	14.334	8.	14.260
4.	14.211		
5.	14.267 *		
	0.184 Amps		
PREVIOUS		NEXT	EXIT

NOTES:

- The * on cell number 5, indicates the cell voltage measurement was not calibrated but is an approximate value based on the raw counts.
- The 0.184 Amps in this example, shows the approximate current draw from the DLC for all the cells. Unless an external power is being used, the more cells that are connected, the larger this number will be.

CELL SIGNAL MILLIVOLTS

CELL SIGNAL MILLIVOLTS			
1.	7.984	6.	1.601
2.	0.492	7.	0.561
3.	-0.085	8.	0.139
4.	-0.381		
5.	0.869		
PREVIOUS		NEXT	
		EXIT	

SNAP COMMUNICATIONS DIAGNOSTICS

When the SNAP SmartMedia Box communications are enabled, an additional page of the Digital Scale Diagnostics is available.

This will scan and list the IDs of any SmartMedia boxes that it finds on the same channel that the indicator is set to.

This screen shows the ID of the SmartMedia Box, the channel that is being used, and the signal strength detected at the SnapComD and SmartMedia Box.

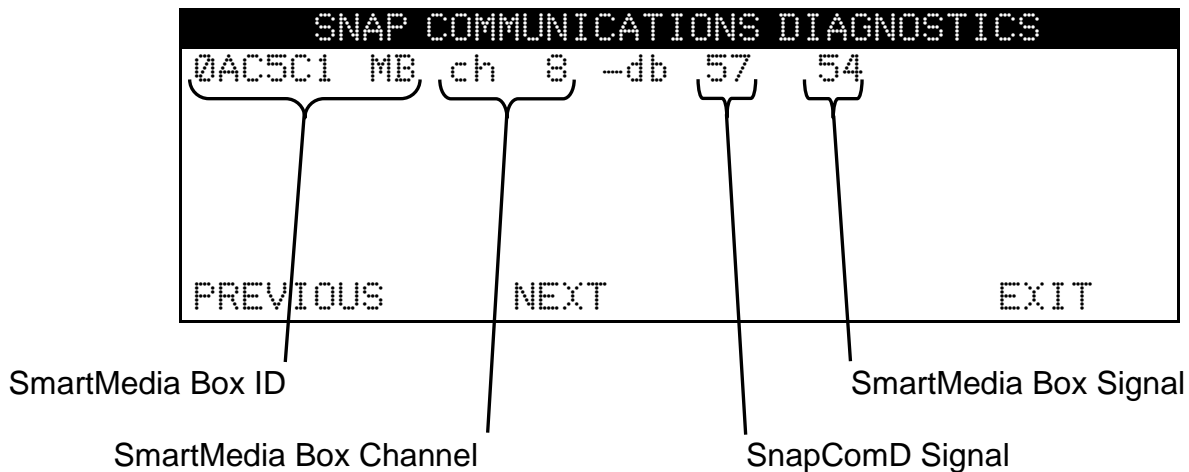

NOTE: The -db numbers are the signal strength detected at the SnapComD and SmartMedia Box. Lower numbers indicate better signal strength.

Hardware Diagnostics

The 225DLC Controller (Digital Scale) Card has four LEDs for diagnostic purposes.

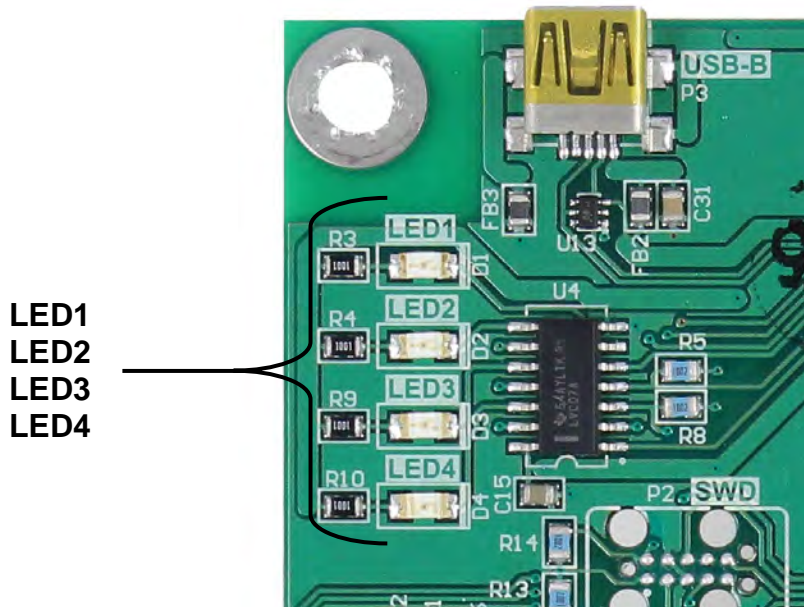

LED1 (RED) – MAIN BOARD TX/RX: Toggles each time the 225DLC controller card and the 225D Mainboard exchange messages.

LED2 (RED) – TX TO LOAD CELL: Toggles each time a message is sent from the 225DLC controller card to the load cells.

LED3 (RED) – RX FROM LOAD CELL: Toggles each time the 225D controller card receives a response from some or all the load cells. Blinking does not mean that it got a response from EVERY load cell. If some load cell does not respond the indicator will drop into INIT MODE.

LED4 (GREEN) – MODE: Indicates the mode of the 225DLC controller card.

INIT MODE – Blinks once per second. If the indicator drops into INIT MODE, it is because the setup is required, or it cannot find all the load cells.

NORMAL MODE – solid ON

DIAGNOSTIC MODE – Blinks twice per second. This should happen when the operator enters the diagnostics menus.

Detecting 225D Board Replacements

The 225D will detect when a 225DLC controller (digital scale) card or 225D mainboard has been replaced using checksums and unique board identification numbers. Based on several parameters it can detect whether the digital scale card was replaced, or the mainboard was replaced and then reconfigure the NEW card or mainboard to the existing scale.

225DLC CONTROLLER (DIGITAL SCALE) CARD REPLACEMENT

If the 225DLC controller (digital scale) card is replaced, the 225D will boot up to this screen:

```
                DLC
              BY CARDINAL
            Revision 0.1.04
NEW CARD FOUND!
WAS DIGITAL SCALE CARD REPLACED?  NO
                YES                      NO
```

The 225D indicator will check whether the digital scale card has been replaced in order to reconfigure the new digital scale card to the existing scale.

If the operator selects YES, then the 225D mainboard will upload the scale configuration to the new digital scale card and the indicator will immediately be able to make weight again.

225D INDICATOR MAINBOARD REPLACEMENT

If a 225D indicator mainboard is replaced, the 225D will boot up to this screen:

```
                DLC
              BY CARDINAL
            Revision 0.1.04
NEW CARD FOUND!
WAS MAINBOARD REPLACED?  NO
                YES                      NO
```

The system will also check whether the mainboard in the 225D indicator has been replaced, so the scale configuration can be downloaded from the 225DLC controller card to the mainboard.

If the operator selects YES, the scale configuration will be downloaded from the 225DLC controller (digital scale) card to the 225D indicator mainboard. Scale configuration includes the number of load cells, all load cell IDs, and individual load cell trim. **NOTE:** Several indicator parameters will need to be entered manually (Interval, Decimal Point Position, Zero Tracking, Filtering, Print Settings, Serial Settings).



NOTE: A dead load calibration will need to be performed (does not require test weights).

225DLC Digital Controller Card Replacement

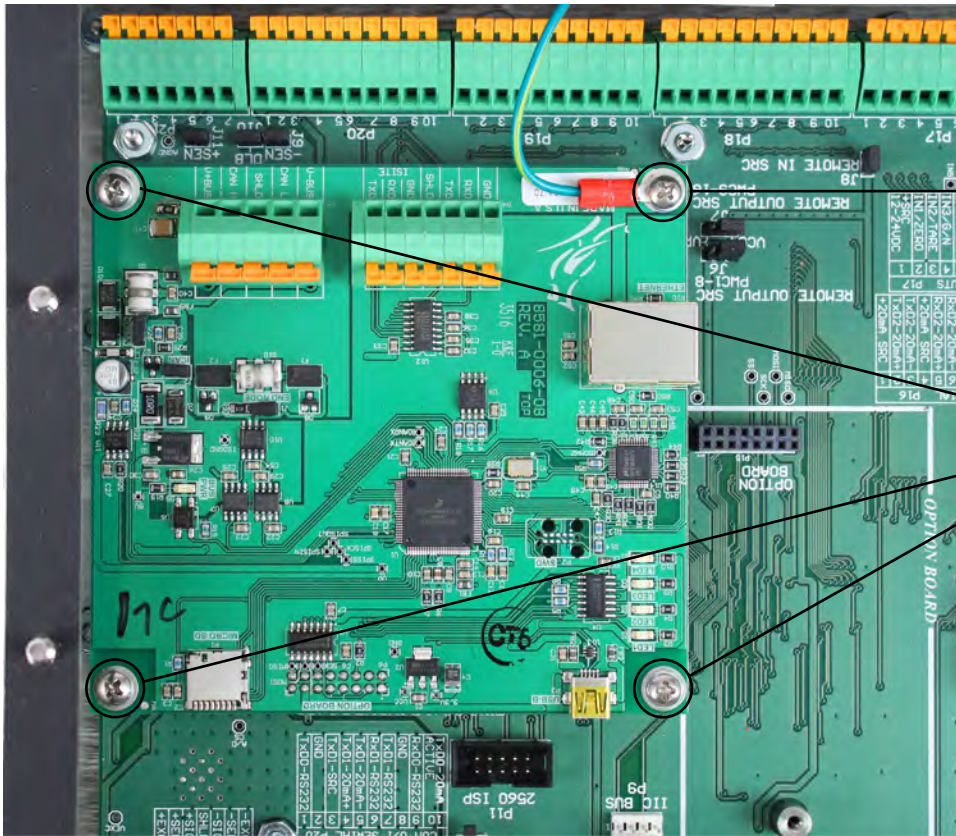

Remove this screw, washer, and the ground wire

Remove the remaining three screws and lock washers

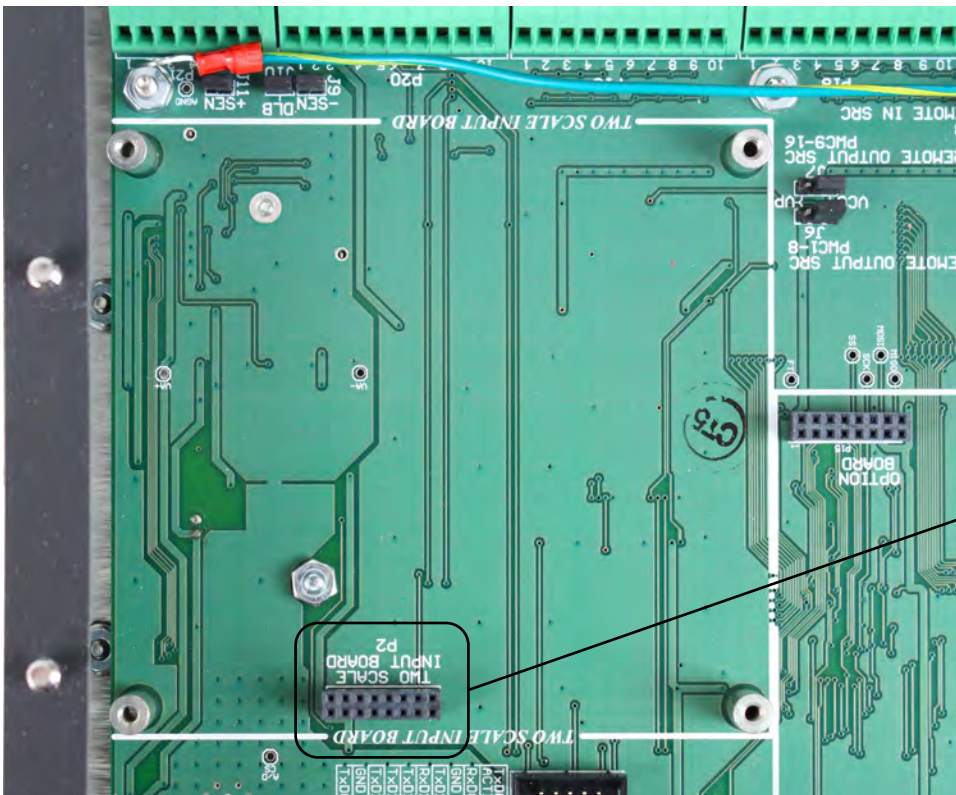

Align pins on 225DLC card with holes in P2.



CAUTION! OBSERVE THE PRECAUTIONS FOR HANDLING STATIC SENSITIVE DEVICES

1. Remove the 225D power cord from the wall outlet.
2. Remove the fourteen acorn nuts securing the rear panel to the main housing.
3. Lift the rear panel from the main housing, taking care not to stretch the cable and wires between the panel and main housing. Lay the rear panel on the workbench/table next to the indicator. **NOTE:** You may need to loosen the gland connectors to allow enough slack in the cable and wires to avoid stretching them.
4. Disconnect the Homerun cable wires from the 225DLC controller card.
5. Remove the four screws and washers securing the 225DLC card to the 225D mainboard. Note that the ground wire for the card is secured by one of these screws.
6. Gently rock the 225DLC card from side to side while pulling up to remove it.
7. To install the new 225DLC card, carefully align the dual row of pins on the top of the 225DLC card (on the trace side of the card) with connector P2 on the mainboard and apply even downward pressure to the edge of the 225DLC card.
8. Align the holes in the 225DLC with the threaded mounting spacers on the mainboard.
9. Secure the 225DLC card to the mainboard, using the four screws and washers removed earlier. Note that one screw and washer should be inserted through the ground wire ring terminal, before using it to secure the card to the mainboard.
10. Reconnect the Homerun cable wires.
11. Ensure that no cables or wires are exposed between the main housing and the rear panel, and then place the rear panel onto the main housing and secure it using the fourteen acorn nuts removed in step 2.
12. Re-insert the 225D power cord into the wall outlet.
13. Press the **ON/OFF** key on the 225D keypad to turn on the indicator.
14. The 225D will boot up to this screen:

```
                DLC
              BY CARDINAL
            Revision 0.1.04
NEW CARD FOUND!
WAS DIGITAL SCALE CARD REPLACED?  NO
                YES                               NO
```

15. The 225D will check whether the digital scale card has been replaced, in order to reconfigure the new digital scale card to the existing scale.
16. If the operator selects YES, then the 225D mainboard will upload the scale configuration to the new digital scale card, and the 225D will immediately be able to make weight again.

225DLC Controller (Digital Scale) Card

USB-B Port

Micro SD Card Slot

LED1
LED2
LED3
LED4

J1
End Node

Ethernet Port for iSite

J2, J3
ICAN Jumpers

Attach Ground wire here

P5
Homerun Cable

P4 P4 – Legacy
Future Use Serial iSite

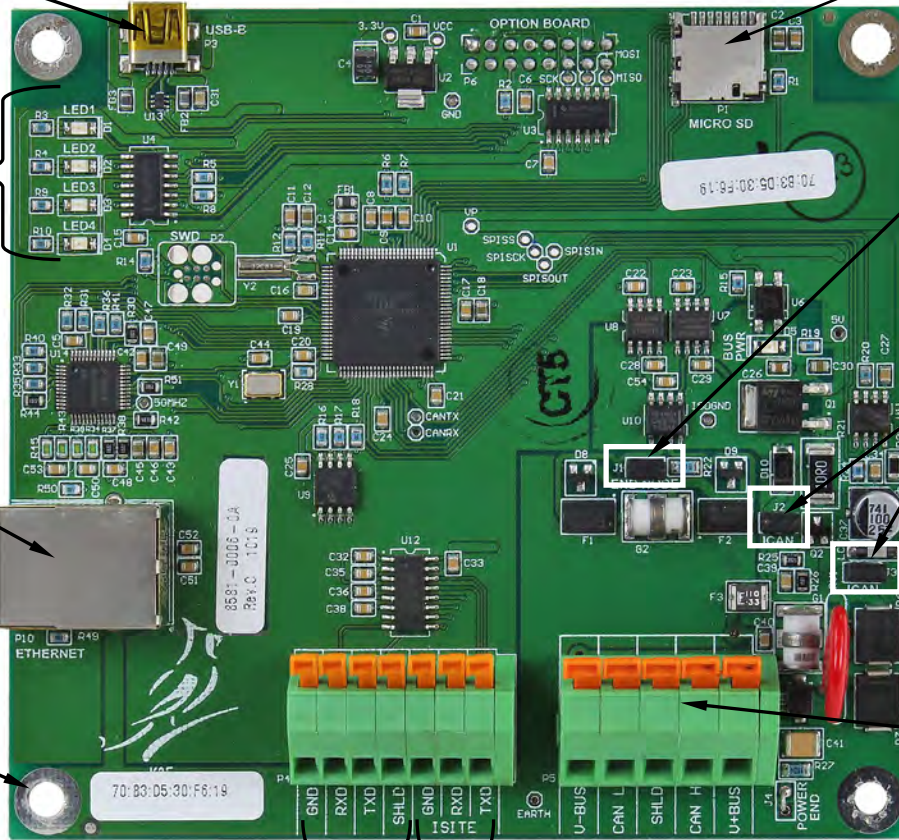

USB-B

This port is used to perform firmware updates to the 225DLC controller card.

Micro SD Card Slot

The Micro SD card slot is not used at this time.

LED 1-4

The LEDs are used for diagnostic purposes. For a complete explanation of their function, refer to the DIGITAL SCALE DIAGNOSTICS, Hardware Diagnostics section of this manual.

Ethernet Port

This port is used to connect the 225D to your network to send information to the cloud for iSite.

J1, End Node Jumper

Jumper J1 is the CAN bus END NODE jumper. **NOTE:** The J1 jumper must be installed for the 225D communications to the scale to operate.

J2, J3 ICAN Jumpers

These jumpers must be OFF (on one pin only or removed) when using the POWER-DLC to power to the digital load cells in the scale. **NOTE:** If these jumpers are ON (installed), the 225D indicator is supplying the power to the digital load cells in the scale, and the POWER-DLC **cannot** be used.



IMPORTANT! The jumpers must be OFF (on one pin only or removed) when the POWER-DLC or an external power source, such as the MB-AC media box is used to power the digital load cells in the scale.

P5, Homerun Cable

The P5 terminal block is used to connect the homerun cable between the 225D indicator and the INDICATOR terminal block in the POWER-DLC. Refer to the table below for terminal connections.

Homerun Cable Connection to P5 Terminal Block

Board Label	Homerun Cable Wire Color	Wire Color if using a Load Cell Cable
SHLD	GRAY	BROWN
V+BUS	RED	WHITE
V-BUS	BLACK	BLUE
CAN H	WHITE	BLACK
CAN L	BLUE or LIGHT BLUE	GRAY

P4, Legacy Serial iSite

This portion of the P4 terminal block is used to connect to Legacy Serial iSite wiring when replacing or updating the indicator in an older system with a 225D.

P4, Future Use

This portion of the P4 terminal block is not used at this time. It is reserved for a future serial connection.

825D Digital Scale Diagnostics

On Screen Diagnostics

The On Screen Diagnostics messages are critical errors that alert the operator from the main screen of setup issues or hardware problems. These messages will be shown to the operator on the main weight screen in real-time when the error happens.

COMMUNICATION ERROR BETWEEN INDICATOR AND SCALE

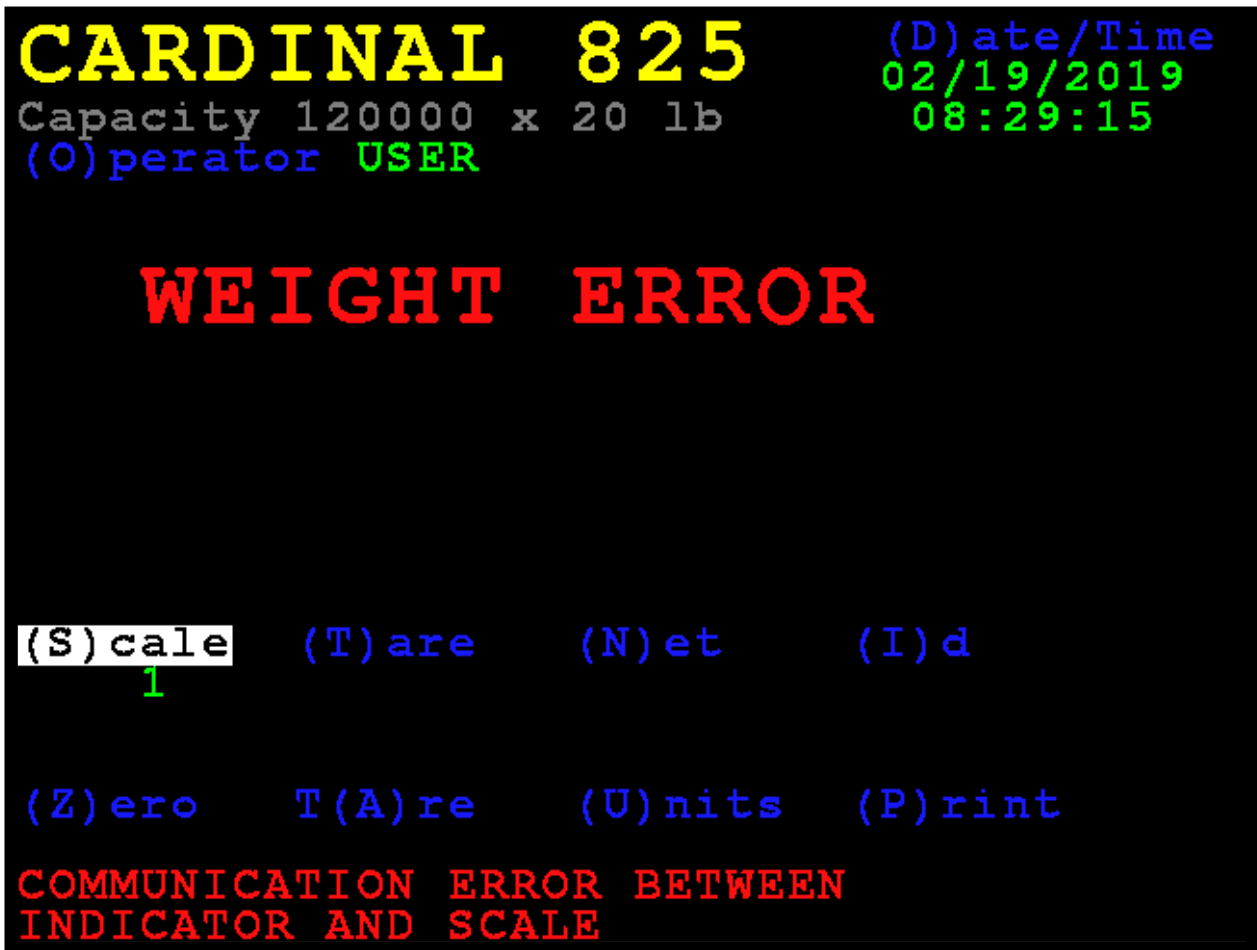

Probable Cause	Items to Check
The homerun cable is damaged or disconnected.	<ul style="list-style-type: none"> • Check that cable is connected correctly. • Check cable for damage. • Use caution on the amount of insulation stripped for the connector. Center wires could short. Must be shorter than the center connector. • Check connector for random strands of wire. • Verify that connector is clear of debris.

COMMUNICATION ERROR BETWEEN LOAD CELLS X AND Y

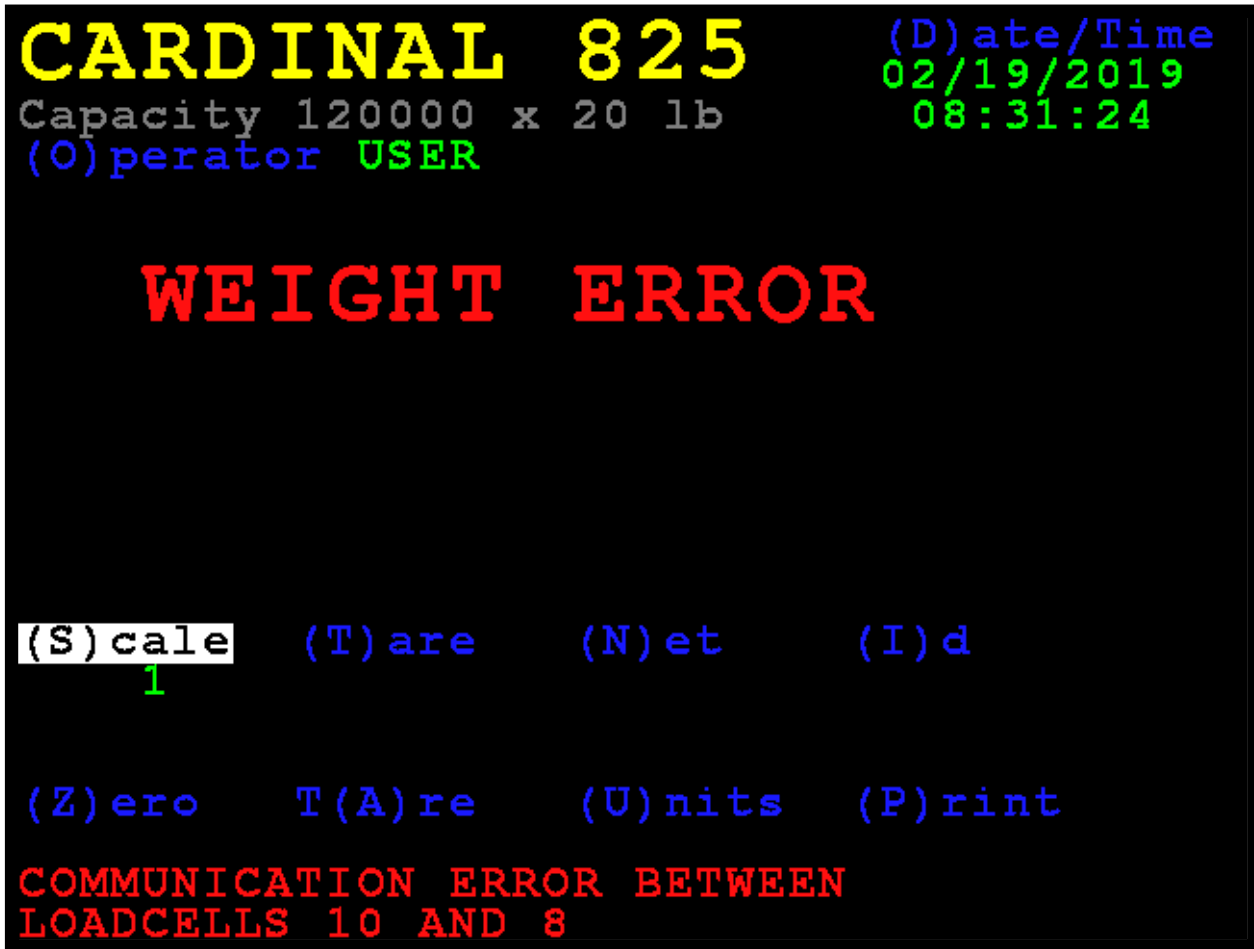

Probable Cause	Items to Check
There is a loss of communication between load cells.	<ul style="list-style-type: none"> • Check that cable is connected correctly. • Check cable for damage. • Verify that connector is clear of debris. • Check load cell COM ports on both load cells.

LOAD CELL X, Y, Z NOT RESPONDING

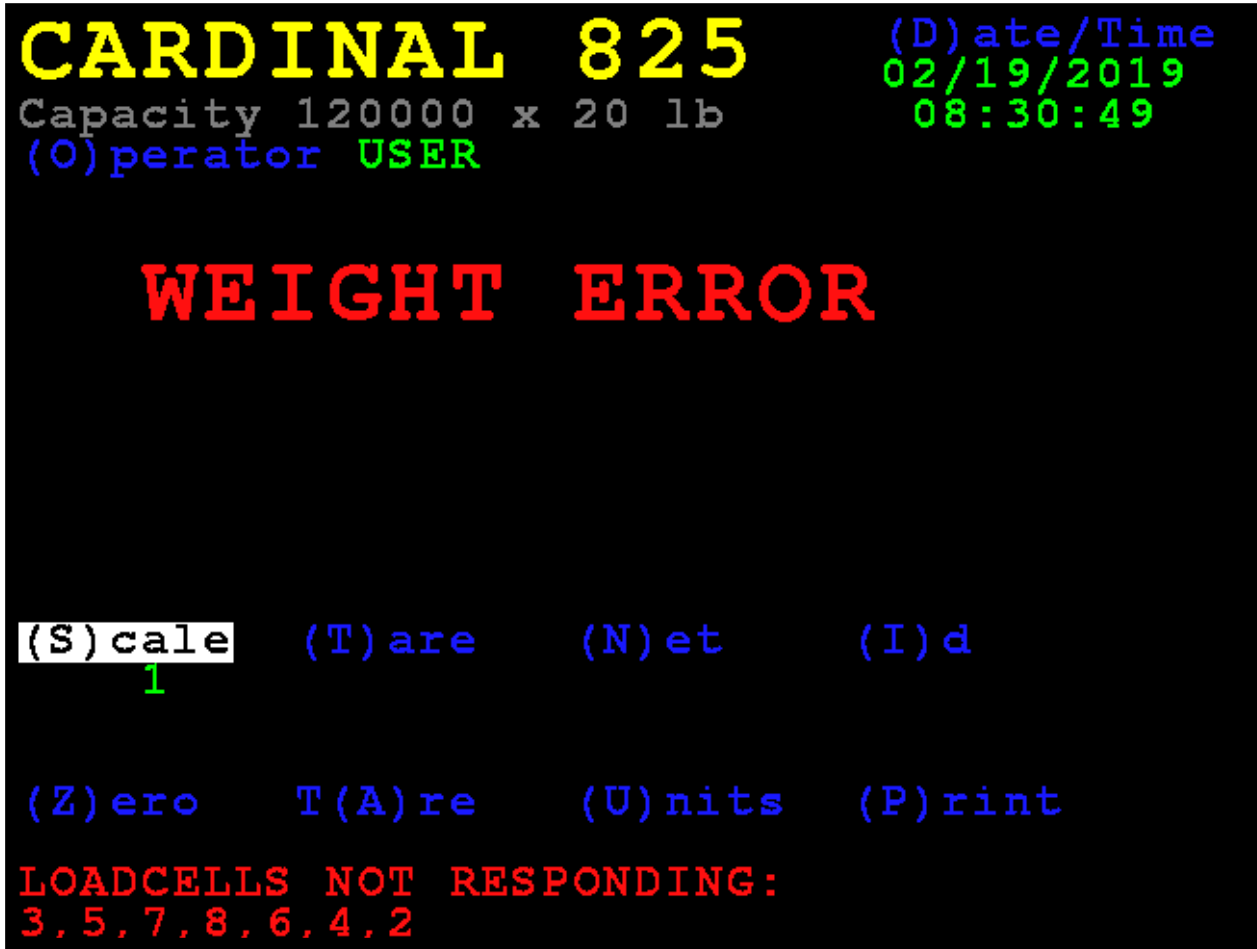

Probable Cause	Items to Check
The 825D cannot detect the exact communication problem with the unresponsive load cell.	<ul style="list-style-type: none"> • Check that cable is connected correctly. • Check cable for damage. • Verify that connector is clear of debris. • Potentially dead load cell.

LOW VOLTAGE DETECTED ON LOAD CELL X, Y, Z

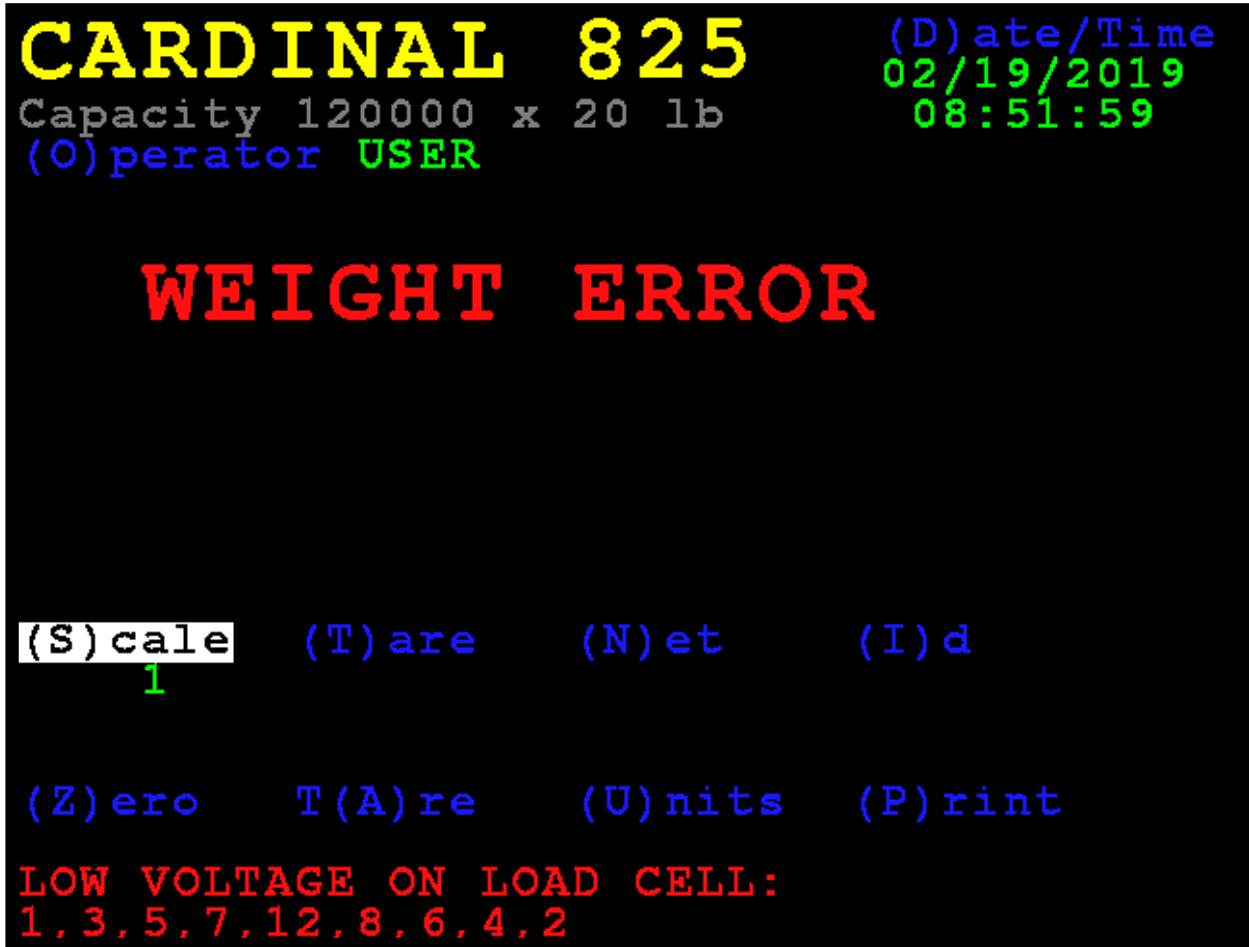

Probable Cause	Items to Check
Low power on a load cell. Load cells at the end of the CAN daisy chain are most susceptible to low voltage errors because of voltage drop along the cable.	<ul style="list-style-type: none"> • Too many load cells on the chain. • Check that cable is connected correctly. • Check cable for damage. • Verify that connector is clear of debris. • Check 825D indicator power supply.

Diagnostic Menu

The Diagnostic Menu is a set of diagnostic tools that give a technician more information about each load cell.

6. DLC Diagnostics

With the **Scale 1 - Calibration Options** screen displayed, press the **6** key, or use the Navigation Keys to select (highlight) **6. DLC Diagnostics**, and then press the **ENTER** key.

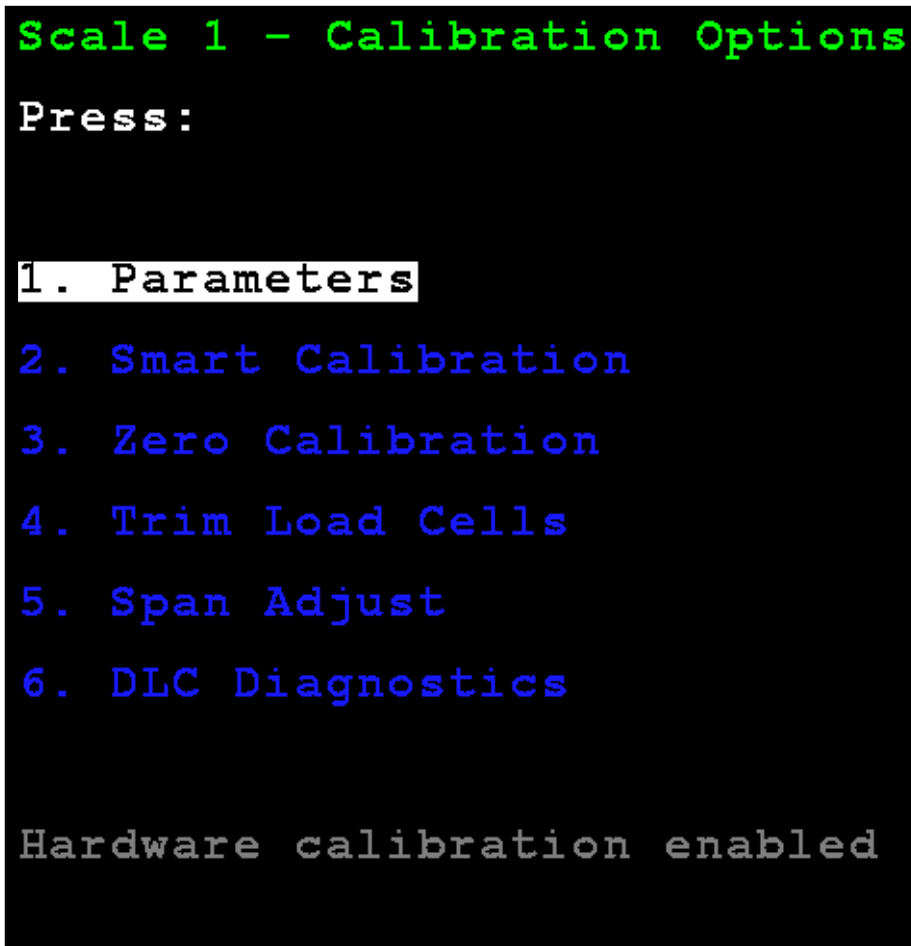

The display will change to show the **Digital Load Cell Diagnostics** screen.

MINIMUM AND MAXIMUM WEIGHTS

Use the Navigation Keys to scroll the display to show all cells.

Press the **X** key to jump to the **Maximum / Minimum Weights** screen from the other diagnostic screens.

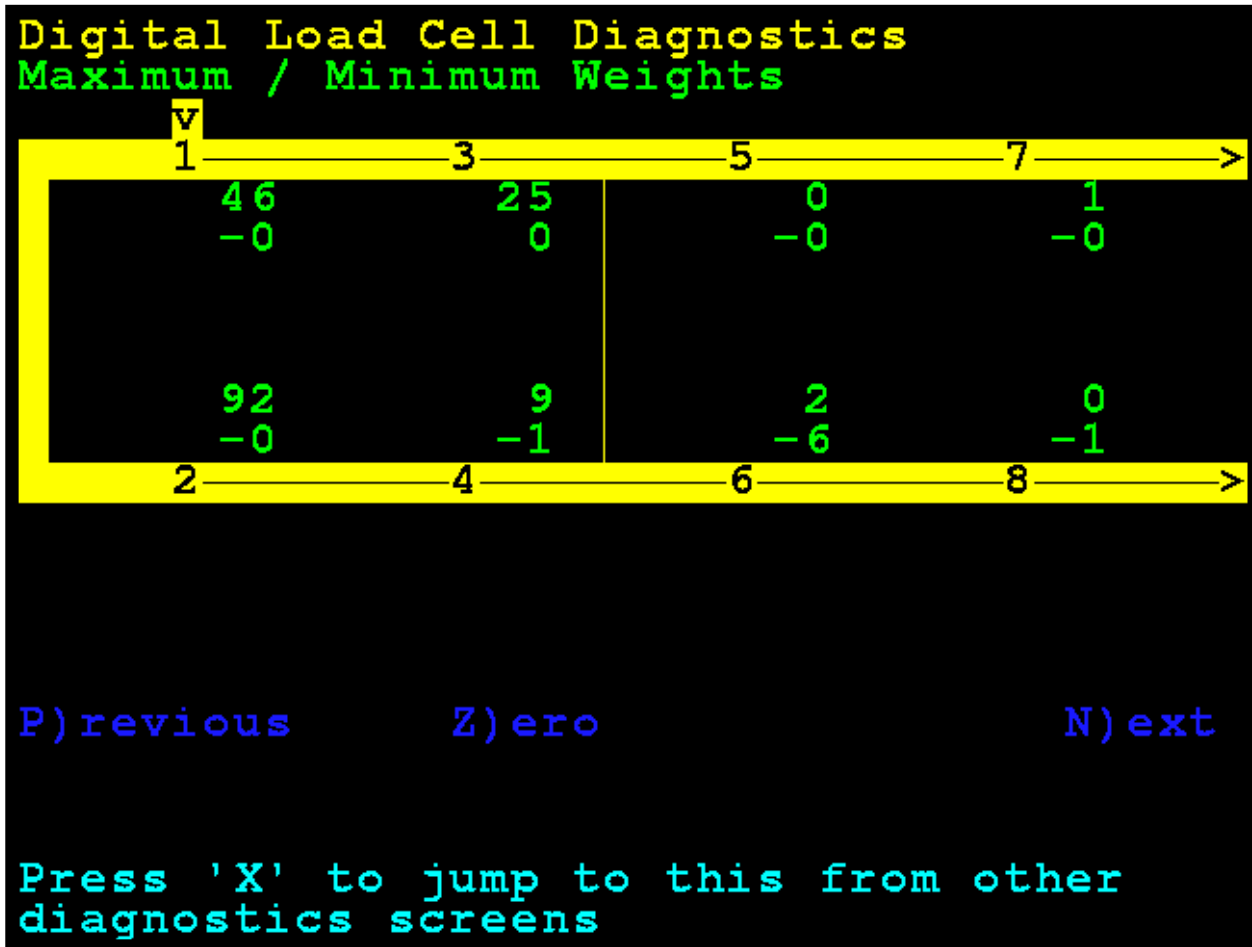

DEADLOAD SHIFT

This shows the live shift from the original calibrated deadload. An asterisk (*) indicates that the deadload shift has been exceeded. The scale must be empty for this to be valid.

Use the Navigation Keys to scroll the display to show all cells.

Press the **D** key to jump to the **Deadload Shift** screen from the other diagnostic screens.

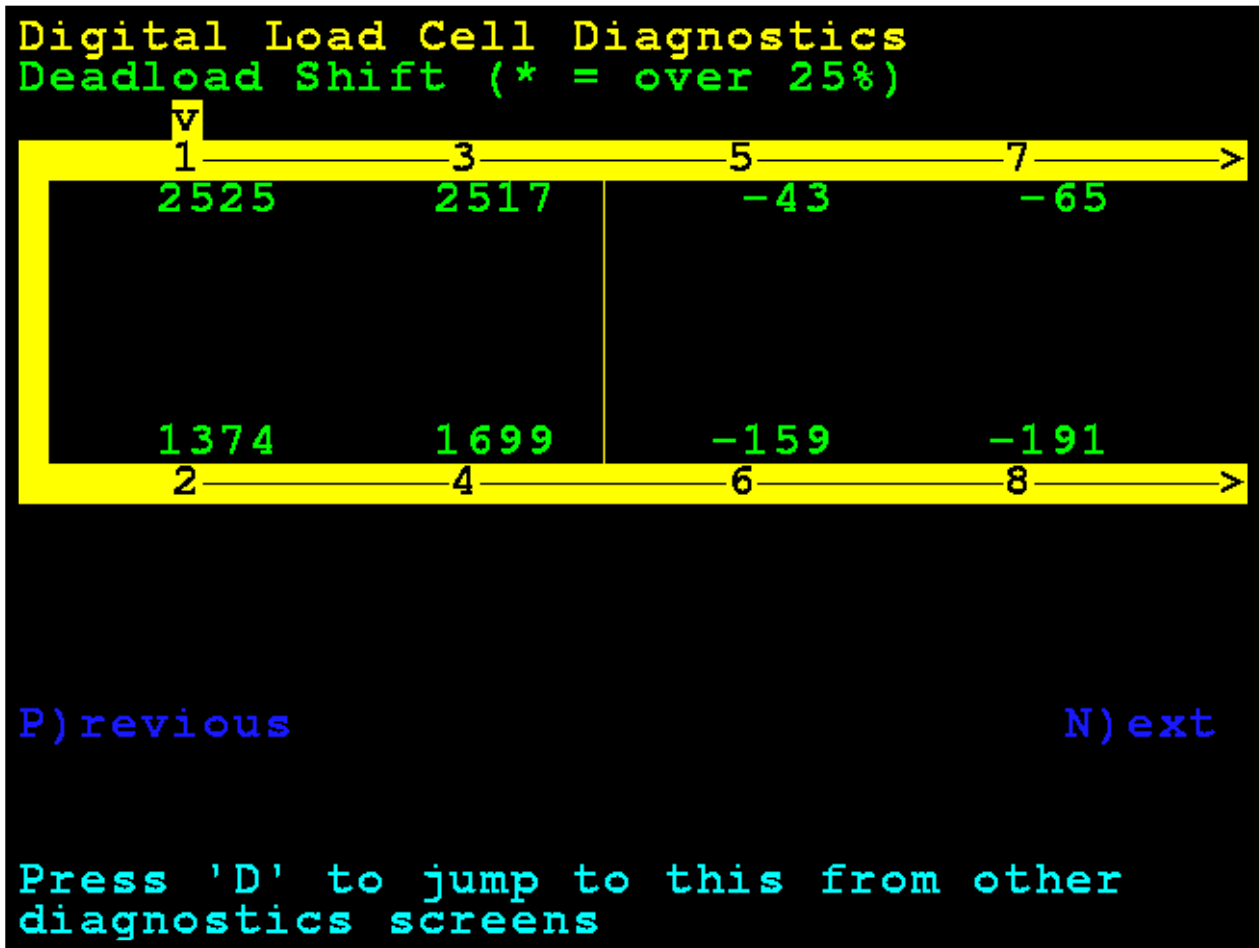

LOAD CELL IDS / SOFTWARE VERSIONS

Use the Navigation Keys to scroll the display to show all cells.

Press the R key to jump to the Load Cell IDs / Software Versions screen from the other diagnostic screens.

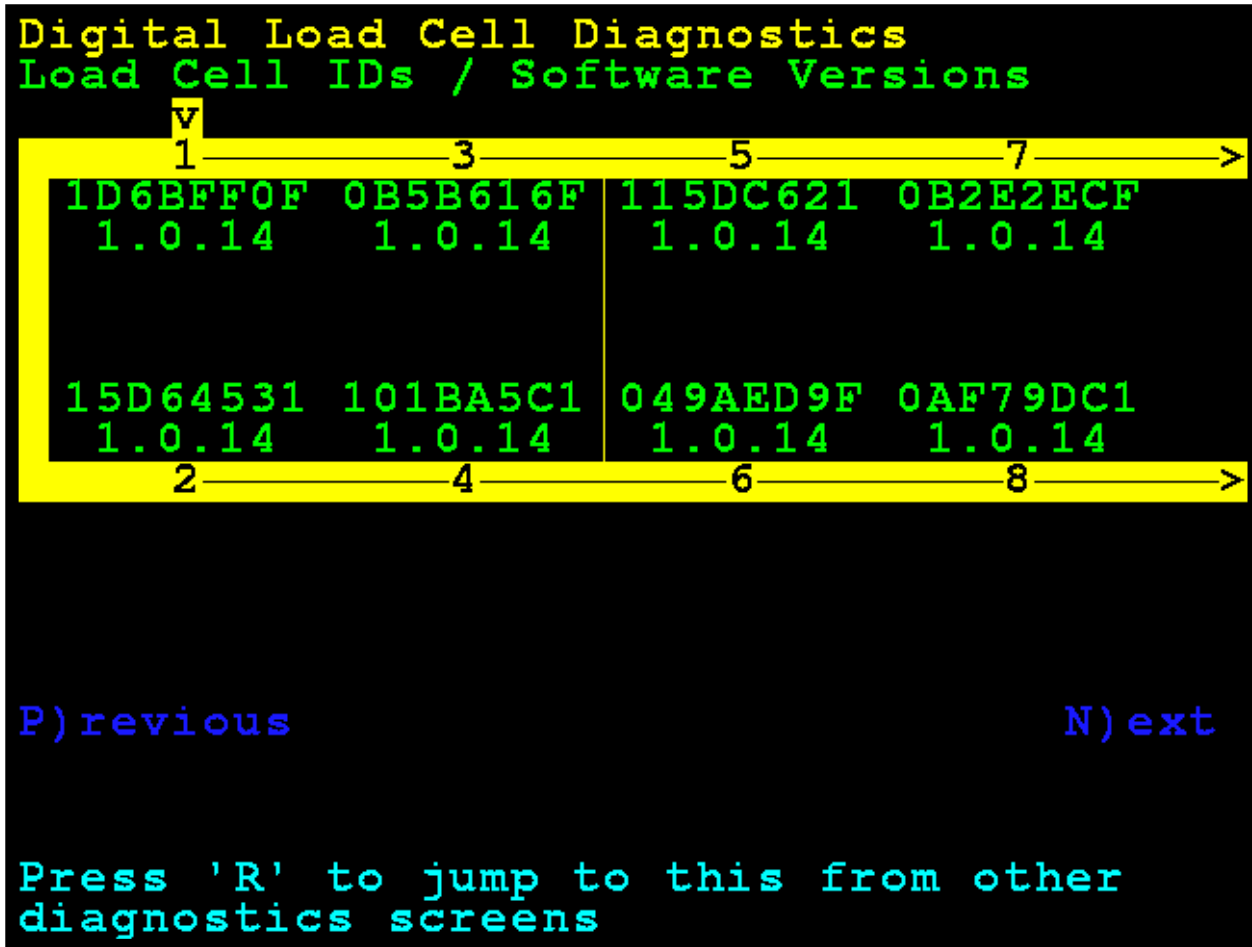

LOAD CELL COMMUNICATION ERROR COUNTS

Use the Navigation Keys to scroll the display to show all cells.

Press the **E** key to jump to the **Load Cell Communication Error Counts** screen from the other diagnostic screens.

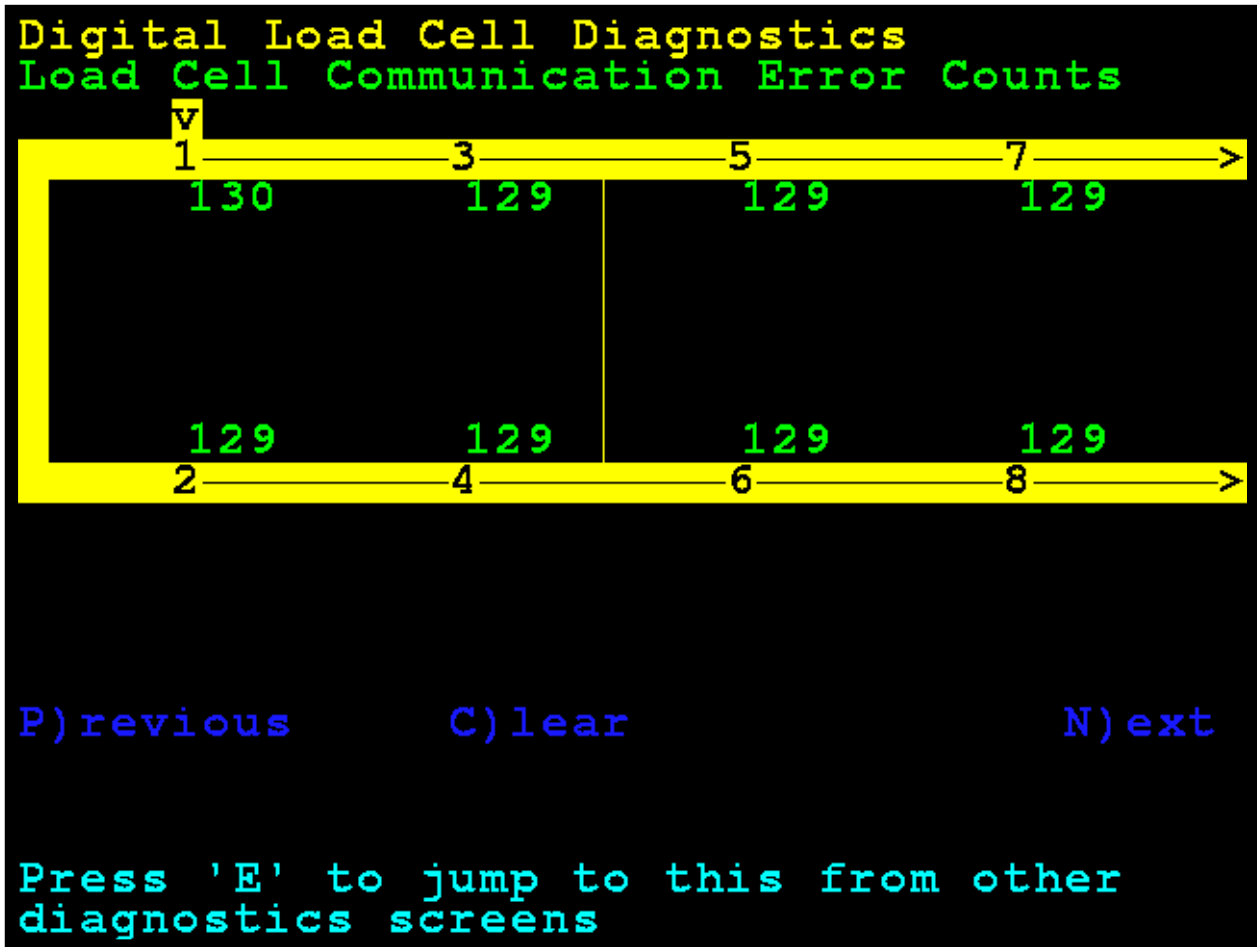

ZERO LOAD CELL COMMUNICATION ERROR COUNTS

Use the Navigation Keys to scroll the display to show all cells.

Press the **C** key to clear the Communication Error Counts.

Press the **E** key to jump to the **Load Cell Communication Error Counts** screen from the other diagnostic screens.

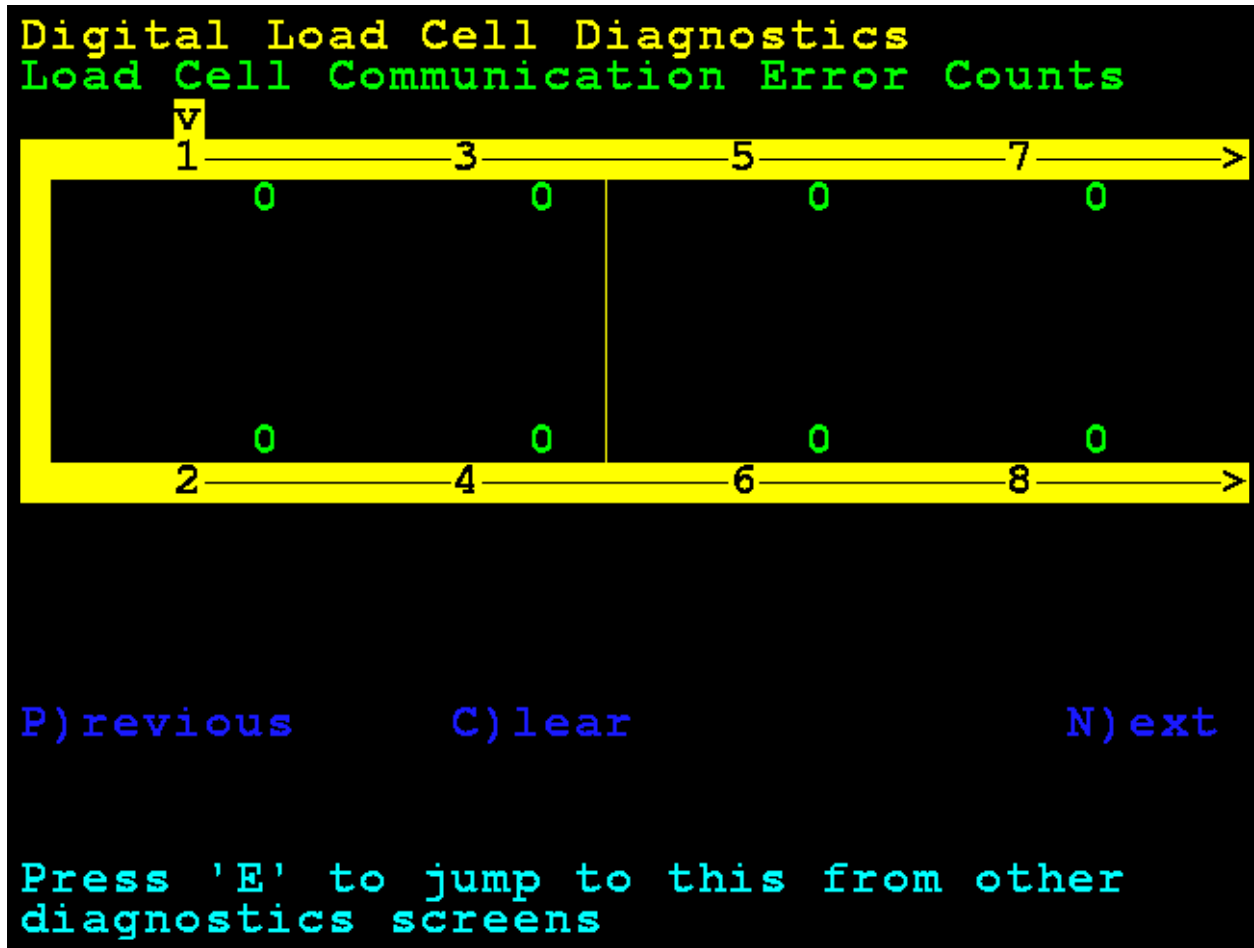

WEIGHT ERROR COUNTS

Weight Error Counts are analog errors that would normally indicate a bad cell.

Use the Navigation Keys to scroll the display to show all cells.

Press the **C** key to clear the Weight Error Counts.

Press the **G** key to jump to the **Weight Error Counts** screen from the other diagnostic screens.

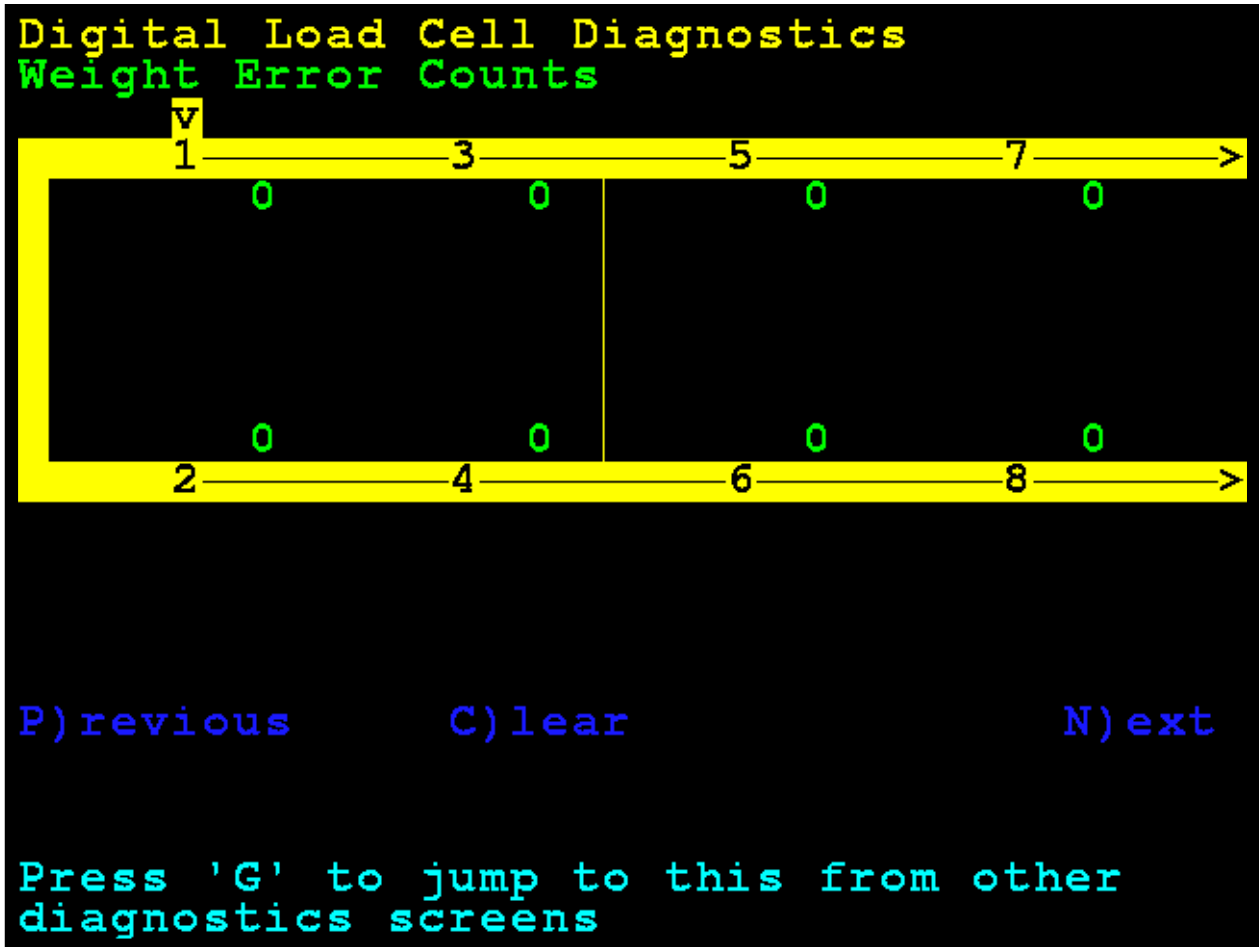

LOAD CELL TEMPERATURES

This is the temperature of the cells in Celsius.

Use the Navigation Keys to scroll the display to show all cells.

Press the **T** key to jump to the **Load Cell Temperatures** screen from the other diagnostic screens.

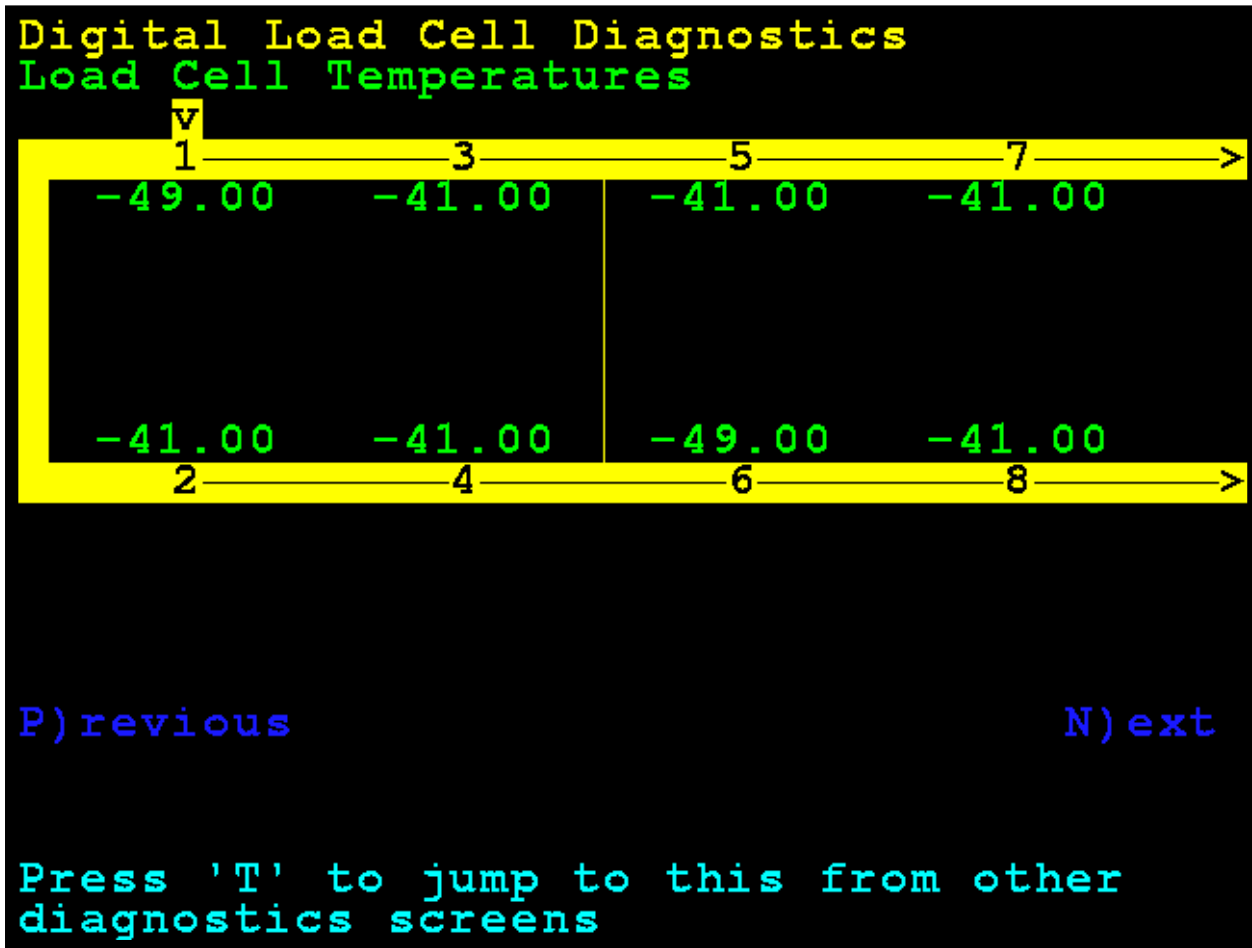

LOAD CELL MILLIVOLTS

Use the Navigation Keys to scroll the display to show all cells.

Press the **M** key to jump to the **Load Cell Millivolts** screen from the other diagnostic screens.

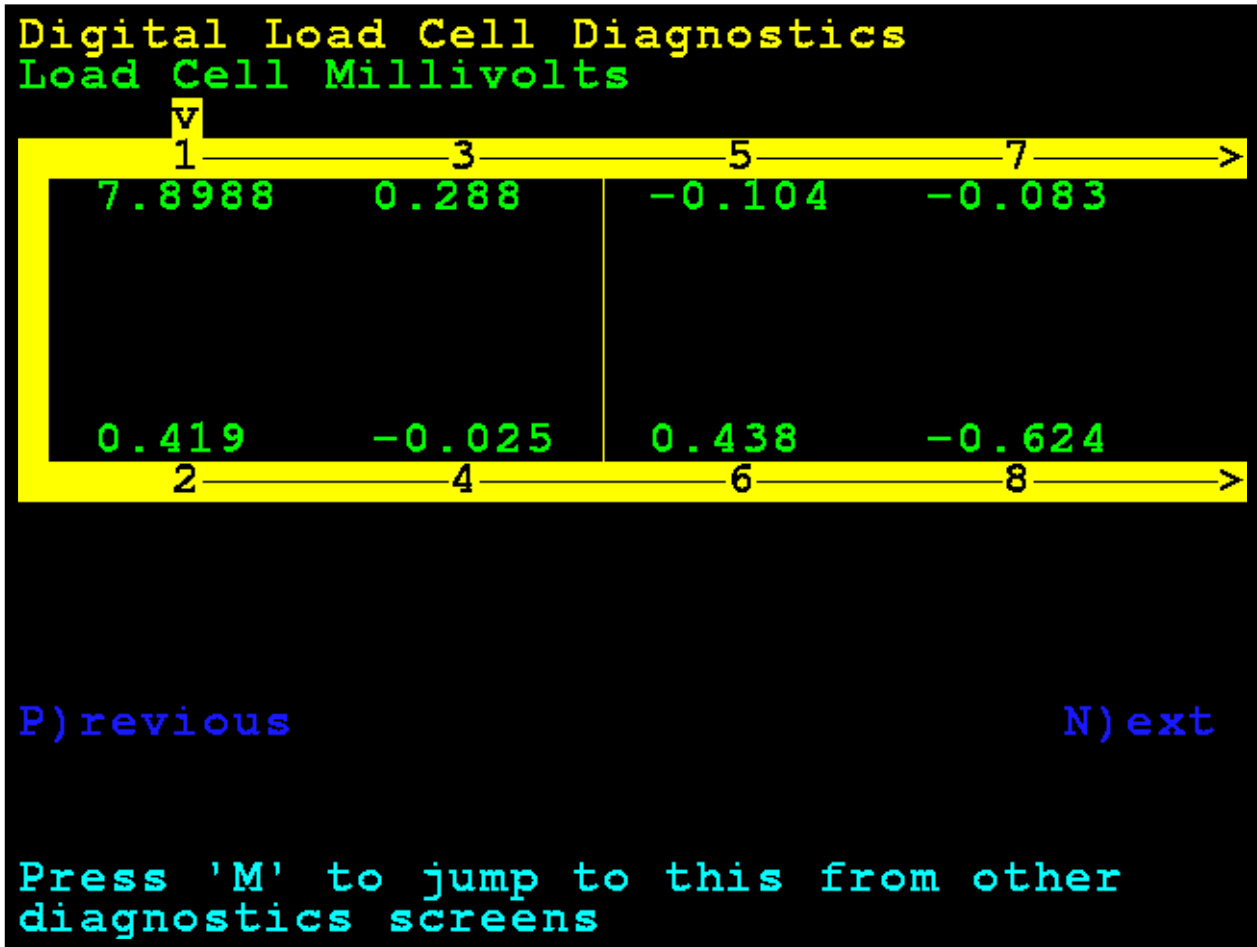

SUPPLY VOLTAGE – RAW COUNT / VOLTAGE

NOTE: An asterisk (*) indicates voltage determination is approximated based on the raw count value.

Use the Navigation Keys to scroll the display to show all cells.

Press the **V** key to jump to the **Supply Voltage – Raw Count / Voltage** screen from the other diagnostic screens.

The screenshot shows a terminal window with the following content:

```
Digital Load Cell Diagnostics
Supply Voltage - Raw Count / Voltage
V
1-----3-----5-----7----->
  1035      1028      1021      1028
 11.268    11.018    11.018    11.080
2-----4-----6-----8----->
  1029      1025      1036      1022
 11.205    11.143    11.105*   10.955
P)revious                                N)ext
Press 'V' to jump to this from other
diagnostics screens
```

Cell	Raw Count	Voltage
1	1035	11.268
2	1029	11.205
3	1028	11.018
4	1025	11.143
5	1021	11.018
6	1036	11.105*
7	1028	11.080
8	1022	10.955

Hardware Diagnostics

The 825-DLC Controller (Digital Scale) Card has four LEDs for diagnostic purposes.

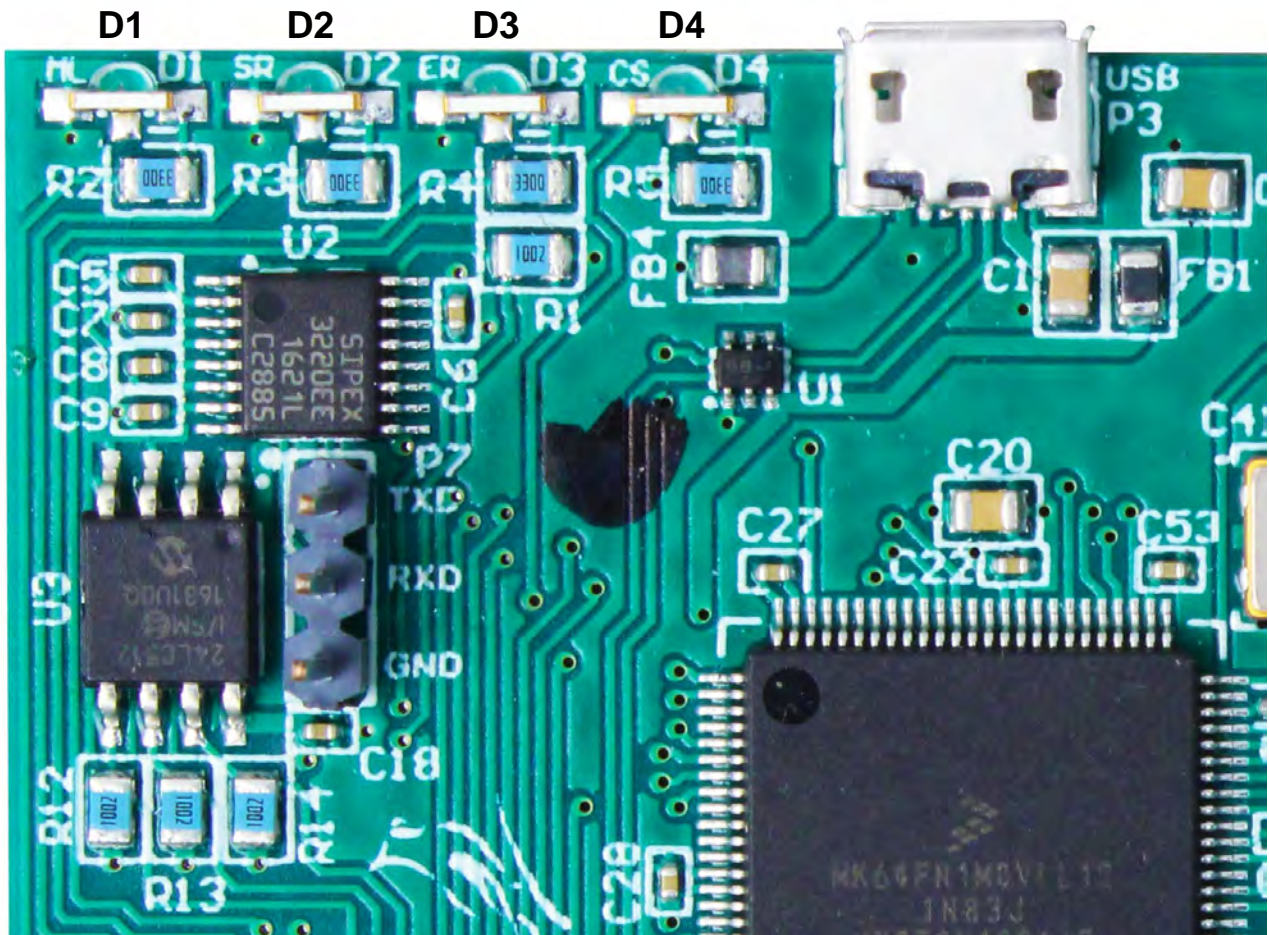

D1 – Blinking = Indicates the 825-DLC card is communicating with the 825D mainboard.

D2 – Blinking = Indicates the 825-DLC card is transmitting messages is to the load cells.

D3 – Blinking = Indicates the 825-DLC card is receiving responses from all assigned load cells.

D4 – Blinking = Indicates 825-DLC card selected from the 825D mainboard.

Detecting 825D Board Replacements

The 825D will detect when an 825-DLC controller (digital scale) card or 825D indicator mainboard has been replaced using checksums and unique board identification numbers. Based on several parameters, it can detect whether the digital scale card or the indicator mainboard was replaced, and then reconfigure the digital scale card or indicator mainboard to the existing scale.

825D-DLC CONTROLLER (DIGITAL SCALE) CARD REPLACEMENT

If the digital scale card is replaced, the 825D will boot up to this screen:

```
CARDINAL 825
Item          Version  01 cards  IEEEEEEEEEE
MnBd DLC      1.21.011 Slot Type  Version
Loader        1.10.013  1    DLC   1.00.001
OS/Std Apps   1.12.021

1. Application program
2. Standard indicator
3. Legal metrology information / Setup
4. Digital Scale Diagnostics
NEW CARD FOUND!
WAS DIGITAL SCALE CARD REPLACED (Y/N)? N
```

The 825D will check whether the digital scale card has been replaced, in order to reconfigure the new digital scale card to the existing scale.

If the operator selects YES, then the 825D indicator mainboard will upload the scale configuration to the new digital scale card, and the 825D will immediately be able to make weight again.

825-DLC Digital Controller Card Replacement



CAUTION! OBSERVE PRECAUTIONS FOR HANDLING STATIC-SENSITIVE DEVICES

17. Remove the 825D power cord from the wall outlet.
18. Remove the fourteen acorn nuts securing the rear panel to the main housing.
19. Lift the rear panel from the main housing, taking care not to stretch the cables and wires between the panel and main housing. Lay the rear panel on the workbench/table next to the indicator.
NOTE: You may need to loosen the gland connectors to allow enough slack in the cable and wires to avoid stretching them.
20. Remove the screw securing the 825-DLC card to the main PC board and then lift the 825-DLC straight up to remove it from the enclosure.
21. Disconnect the Homerun cable wires (and any other wires or cables) from the 825-DLC card.
22. On the new 825-DLC card, connect the Homerun cable wires (and any other wires or cables).
23. To install the new 825-DLC card, carefully align the card edge connector with the PCI Express Bus (PCIe) slot and apply even downward pressure to the edge of the 825-DLC card.
24. Secure the 825-DLC card to the mainboard with the screw removed earlier.
25. Ensure that no cables or wires are exposed between the main housing and the rear panel, and then place the rear panel onto the main housing and secure it using the fourteen acorn nuts removed in step 2.
26. Re-insert the 825D power cord into the wall outlet.
27. Press the **ON/OFF** key on the 825D keypad to turn it on.

28. The 825D will boot up to this screen:

```
CARDINAL 825
Item          Version  01 cards  I[ ]
MnBd DLC      1.21.011 Slot Type  Version
Loader        1.10.013  1   DLC    1.00.001
OS/Std Apps   1.12.021

1. Application program
2. Standard indicator
3. Legal metrology information / Setup
4. Digital Scale Diagnostics
NEW CARD FOUND!
WAS DIGITAL SCALE CARD REPLACED (Y/N)? N
```

29. The 825D will check whether the option card has been replaced, in order to reconfigure the new option card to the existing scale.

30. If the operator selects Y, then the 825D mainboard will upload the scale configuration to the new 825-DLC card, and the 825D will immediately be able to make weight again.

825-DLC Controller (Digital Scale) Card

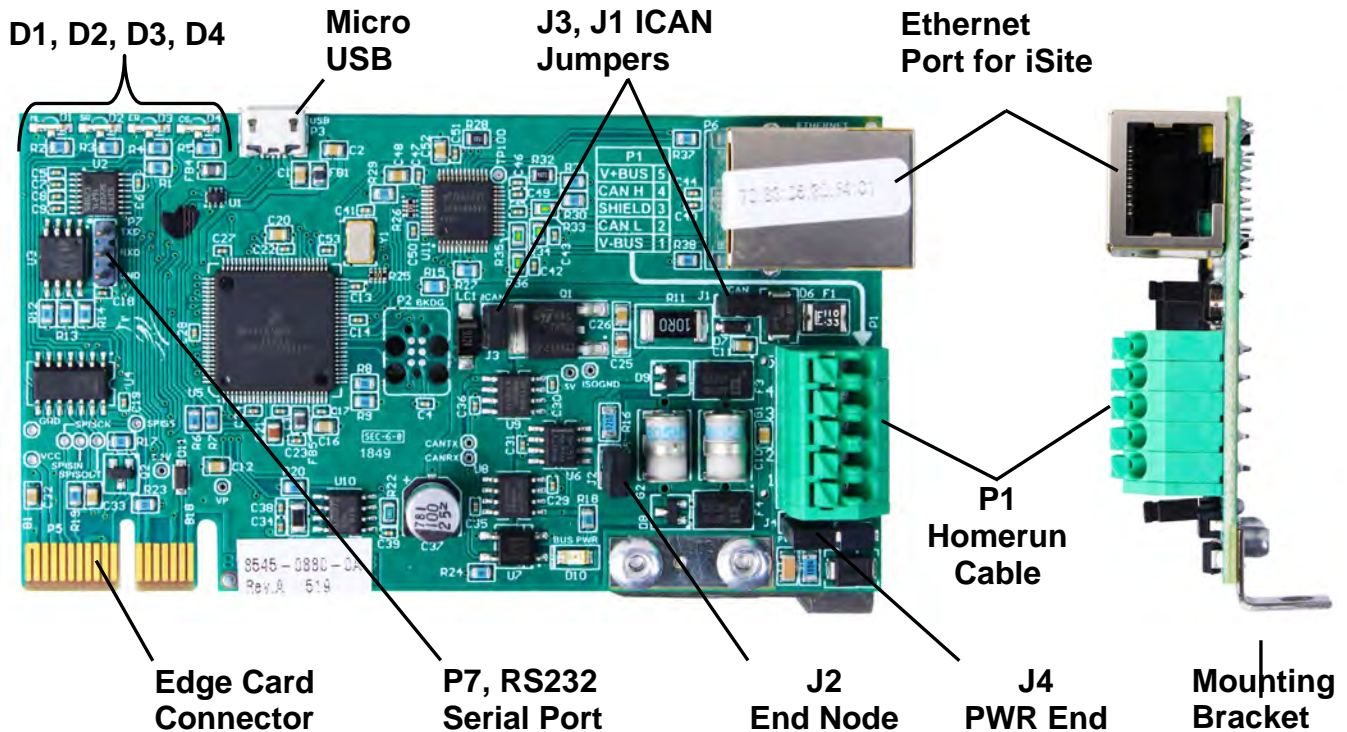

J2, End Node Jumper

Jumper J2 is the CAN bus END NODE jumper and should be ON (installed).

NOTE: The 825D is one end of the CAN bus connections and the J2 jumper must be installed for the 825D communications to the scale to operate.

J1, J3 ICAN Jumpers

These jumpers must be OFF (on one pin only or removed) when using the POWER-DLC to power to the digital load cells in the scale. **NOTE:** If these jumpers are ON (installed), the 825D indicator is supplying the power to the digital load cells in the scale, and the POWER-DLC **cannot** be used.



IMPORTANT! The jumpers must be OFF (on one pin only or removed) when the POWER-DLC or an external power source, such as the MB-AC media box is used to power the digital load cells in the scale.

J4, PWR END

This jumper should be installed if the power to the digital load cells in the scale over the CAN bus cable (Homerun Cable) is provided by the 825D and not the POWER-DLC or an external power source such as the MB-AC media box.

P1, CAN Connection to Scale (Homerun Cable)

The P1 terminal block is used to connect the homerun cable between the 825D indicator and the INDICATOR terminal block in the POWER-DLC. Refer to the table below for terminal connections.

825DLC Controller Card P1 Terminal Connections

Board Label	Homerun Cable Wire Color	Wire Color if using a Load Cell Cable
SHLD	GRAY	BROWN
V+BUS	RED	WHITE
V-BUS	BLACK	BLUE
CAN H	WHITE	BLACK
CAN L	BLUE or LIGHT BLUE	GRAY

Micro USB

This connector is used to perform firmware updates to the 825-DLC controller card.

P6, Ethernet

This connector is used to connect the 825D to your network to send information to iSite.

P7, RS232 Serial Port

The P7 pins are used to connect to Legacy iCAN and for future connections.

LED 1-4

The LEDs are used for diagnostic purposes. For a complete explanation of their function, refer to the DIGITAL SCALE DIAGNOSTICS, Hardware Diagnostics section of this manual.

MAINTENANCE INSTRUCTIONS

Maintenance Instructions for High Usage Weighments

1. A High Usage Weighment Scale is one with 150 or more weighments per day.
2. A weekly maintenance inspection should be performed.
 - A. Check all load cells for and clear debris around load cells.
3. Check beneath the bridge for debris build-up between the foundation and the bridge. Remove debris from each end of the scale.
4. Test the scale with a truck carrying a typical load (i.e., a typical scale weighment).
 - A. Place the truck on the scale and take a reading.
 - B. Remove the truck, turn around and re-enter the scale.
 - C. The readings must repeat within ± 0.2 percent of the applied load.
Example: 80,000 lb truck, the readings should be within ± 8 Grads (160 lb).
5. Structural Bridge Inspection
 - A. Drive a loaded truck slowly across the scale.
 - B. Observe the deck plate at the tandem axles.
 - C. Excessive deflection, under the tandem axle loads, will readily reveal structural damage (i.e., a broken weld, stringer, or cross member).

The above inspection procedure will require less than one hour but will ensure that the scale is well maintained and accurate. Quarterly, have the scale checked with known weights (i.e., a routine scale company test).

TROUBLESHOOTING GUIDE

It can happen sometimes; the truck scale installation has been completed, but the system just doesn't work, or it has been running smoothly and then a problem occurs. Before calling Cardinal Scale for assistance, there are a few things to check first that can be done to get the system back up and running. Remember, that there is a logical explanation for all problems, and for troubleshooting to be successful, it must be approached in a logical and rational manner.

The 225D and 825D indicators used on the ARMOR Digital Truck scales are equipped with software that indicates when an error in the operation takes place. Should a problem be detected, an error message will be displayed alerting the operator to that condition. The following is a list of some of the top system problems and recommended solutions to those problems.

DISPLAYED ERROR MESSAGES

REPLACE LOAD CELL X

SOLUTION:

- A. Using a NEST, test the load cell.
- B. If the load cell fails the test on the NEST, replace the indicated load cell.
- C. Verify calibration on the scale.

LOW VOLTAGE DETECTED CELL X

SOLUTION:

- A. Using a NEST, test the load cell.
- B. If the load cell fails the test on the NEST, replace the indicated load cell.
- C. If the load cell passes the test on the NEST, proceed with the following:
- D. Cut the end off an extra load cell cable and strip back the wires to make a test cable.
- E. Ensure the scale is powered up.
- F. Remove the End Node (terminator) from the last load cell in the loop and connect the test cable to the port on the load cell where the End Node (terminator) was.
- G. Use a DVM to measure the DC voltage between the White wire (V+ Bus) and Blue wire (V- Bus). The voltage should be a minimum of 9 VDC. *Note that the voltage depends on the number of load cells in the loop.*
- H. If the system voltage is above 9 VDC, replace all the load cells indicated in the LOW VOLTAGE error message displayed.

LOW VOLTAGE DETECTED CELL X, Cont.

SOLUTION:

- I. If the system voltage is below 9 VDC, proceed as follows:
- J. First, remove the White (V+ Bus) and Blue (V- Bus) wires from the Homerun cable on the DLC Card, and using a DVM, read the voltage on the connector. This should be a *minimum* of 14 VDC on the 225DLC (11.5 VDC on the 825-DLC). If the voltage is low, replace the DLC card. If it is a minimum of 14 VDC on the 225DLC (or 11.5 VDC on the 825-DLC) proceed as follows:

- K. Measure the current draw on the system. Remove the White (V+ Bus) wire from the DLC card. Put one lead of a DVM in the (V+ Bus) terminal on the DLC card. Attach the other lead of your DVM to the White (V+ Bus) wire going to the scale. Place your DVM in the Milliamps range. Note that on some DVM's, you may have to move the lead position from the normal position to the 0-400 milliamps range.

- L. On the 225D, you should read approximately 200 milliamps of current through an 8-load cell system (each load cell will pull approximately 25 milliamps). A 10-load cell system would read approximately 250 milliamps. Tolerance is +/- 15 milliamps.

On the 825D, you should read approximately 250 milliamps of current through an 8-load cell system (each load cell will pull approximately 30 milliamps). A 10-load cell system would read approximately 300 milliamps. Tolerance is +/- 15 milliamps.

- M. If the value is out of range, disconnect all load cell cables and read the current draw with no cells connected. Now, connect the cables to the load cells one at a time, and make sure that the current draw increases each time a load cell is connected.
- On the 225D, the current draw should increase by approximately 21 milliamps with each load cell connected.
 - On the 825D, the current draw should increase by approximately 25 milliamps with each load cell connected.

If you find that connecting a load cell gives you a suspect reading, try it with a different cable. If the reading is still bad, replace the load cell.

- N. Proceed through testing the current draw on all cables and load cells, then retest the system voltage at the last load cell (End Node) in the loop. If the reading is still below 9 VDC replace the DLC card and check the voltage again.
- O. For a large number of cells and/or a long Homerun cable, an external 24 VDC power supply may be required. Consult the factory for recommendations.

CURRENT DRAW MORE THAN 150% OF CAPACITY

SOLUTION:

- A. Cut the end off an extra load cell cable and strip back the wires to make a test cable.
- B. Ensure the scale is powered up.
- C. Remove the End Node (terminator) from the last load cell in the loop and connect the test cable to the port on the load cell where the End Node (terminator) was.
- D. Use a DVM to measure the DC voltage between the White wire (V+ Bus) and Blue wire (V- Bus). The voltage should be a minimum of 9 VDC. *Note that the voltage depends on the number of load cells in the loop.*
- E. If the system voltage is below 9 VDC, proceed as follows:
- F. Measure the current draw on the system. Remove the White (V+ Bus) wire from the DLC card. Put one lead of a DVM in the (V+ Bus) terminal on the DLC card. Attach the other lead of your DVM to the White (V+ Bus) wire going to the scale. Place your DVM in the Milliamps range. Note that on some DVMs, you may have to move the lead position from the normal position to the 0-400 milliamps range.
- G. On the 225D, you should read approximately 200 milliamps of current through an 8-load cell system (each load cell will pull approximately 25 milliamps). A 10-load cell system would read approximately 250 milliamps. Tolerance is +/- 15 milliamps.

On the 825D, you should read approximately 250 milliamps of current through an 8-load cell system (each load cell will pull approximately 30 milliamps). A 10-load cell system would read approximately 300 milliamps. Tolerance is +/- 15 milliamps.

- H. If the value is out of range, disconnect all load cell cables and read the current draw with no cells connected. Now, connect the cables to the load cells one at a time, and make sure that the current draw increases each time a load cell is connected.
 - On the 225D, the current draw should increase by approximately 21 milliamps with each load cell connected.
 - On the 825D, the current draw should increase by approximately 25 milliamps with each load cell connected.

If you find that connecting a load cell gives you a suspect reading, try it with a different cable. If the reading is still bad, replace the load cell.

- I. Proceed through testing the current draw on all cables and load cells, then retest the system voltage at the last cell (End Node) in the loop. If the reading is still below 9 VDC replace the DLC card and check the voltage again.

LOAD CELL X NOT RESPONDING

SOLUTION:

- A. Using a jack, raise the weighbridge at the load cell location to remove the deadload from the load cell.
- B. Using a NEST, run the automated load cell test.
- C. If the load cell fails the NEST test, replace the load cell.
- D. If the load cell passes the NEST test, proceed to the error message,

COMMUNICATIONS ERROR BETWEEN INDICATOR AND SCALE

- E. If multiple load cells are not responding, confirm that the Start Node and End Node load cells in the loop match the settings in the indicator.

COMMUNICATIONS ERROR BETWEEN INDICATOR AND SCALE

SOLUTION:

- A. Remove power to the indicator and leave it off for a few minutes. Apply power to the indicator. If the indicator displays weight, proceed with normal operations. Otherwise, follow the next steps to determine the problem.

NOTE: If the indicator works for a few minutes, then the error message appears again, install a ground wire between the 225D (825D) and the scale ground rod.

- B. Go to the Load Cell Assignment screen on the indicator and write down all the load cell IDs and their corresponding scale locations (NOT the location in the data loop).
- C. If a Cardinal Digital Load Cell Simulator is available, remove the Homerun cable from the first load cell in the loop and attach it to the simulator.
- D. Go to the Scale Setup screen and change the number of load cells to “1” and assign the simulator ID to that load cell position. The 225D (825D) should display CELL RESPONDED. If NO CELL RESPONSE is displayed, return to the Calibration screen, and perform a **ZERO CAL**. Return to the Weight screen, and cycle power (turn off, then back on) to save the settings. The 225D (825D) should display weight when the slide on the simulator is moved.
- E. If the scale will not function with the simulator, go to the Calibration screen, select SmartCal, and attempt to calibrate the scale.
- F. If the scale will not calibrate with the simulator, using a short test cable, connect the simulator directly to the 225DLC (825-DLC) card, bypassing the Homerun cable. If the 225D (825D) will not recognize and communicate with the simulator, the 225DLC (825-DLC) card is bad and will need to be replaced.
- G. If the scale will calibrate with the simulator connected directly to the 225DLC (825-DLC) card, use a NEST, and perform the cable test on the Homerun cable.

COMMUNICATIONS ERROR BETWEEN INDICATOR AND SCALE, Cont.

SOLUTION:

- H.** If a NEST is not available, proceed with the following instructions to check the Homerun cable for shorts:
1. Disconnect the Homerun cable from the load cell (Start Node).
 2. Starting with one wire, check the resistance between it and each of the other wires one at a time. With a DVM this should always read “OL” to indicate there is no current flow between that pair of wires.
 3. After checking the first wire take the next wire and check it for shorts to the remaining three wires.
 4. Continue this procedure until all wires are tested for shorts to all other wires.
- I.** If the Homerun cable, 225DLC (825-DLC), and 225D (825D) check good with the simulator, we need to test each load cell in the loop by starting with the first load cell.
- Go to the Scale Setup screen and enter “1 Loadcell” to select that cell, assign it to scale one, and enter the ID for the load cell you are connected to. Press ENTER. The 225D (825D) should display CELL RESPONDED, indicating that the load cell is communicating and good. If NO CELL RESPONSE is displayed, return to the Calibration screen, and perform a **ZERO CAL**. Return to the Weight screen, and cycle power (turn off, then back on) to save the settings. If the 225D (825D) displays weight, zero the indicator, then stand on the deck over the load cell to confirm the operation. If the load cell fails to respond, replace the load cell.
- J.** Next, connect the next load cell in the loop. Go to the Scale Setup screen and enter “Number of Cells 2”. Enter the ID for the second load cell. Press ENTER. The 225D (825D) should display CELL RESPONDED, indicating that the second load cell is communicating and good. If NO CELL RESPONSE is displayed, return to the Calibration screen, and perform a **ZERO CAL**. Return to the Weight screen, and cycle power (turn off, then back on) to save the settings. If the 225D (825D) displays weight, zero the indicator, then stand on the deck over the second load cell to confirm the operation. If the load cell fails to respond, replace the load cell.
- K.** Continue adding load cells one at a time until you have a load cell that will not communicate. When that occurs, first replace the cable connecting the last good load cell to the load cell you are testing, to see if a different cable resolves the failure. If it does, proceed to the next load cell to test. If a different cable does not correct the failure, place a new load cell in the current position and input that load cell ID, and see if it responds. If the new load cell does not respond, place the new load cell in the previous position to see if it will communicate through it.
- L.** Continue this process until all load cells are working and making weight. After all load cells are communicating and making weight, go back into the Load Cell Setup and enter the load cell IDs in their correct scale position. Cycle power (turn off, then back on) to save the settings, perform a **ZERO CAL**, and then verify calibration.

LOAD CELL X HAS NO ADDRESS

SOLUTION:

- A. Go to the Scale Setup screen and enter the load cell ID in the correct scale location.

COMMUNICATION ERROR BETWEEN LOADCELLS X AND Y

SOLUTION:

- A. Use the NEST to test the suspect load cell cable for defects.
- B. If the load cell cable tests good, use the NEST to test the two connecting load cells.
- C. If a NEST is not available, replace the suspect load cell cable with a new load cell cable and confirm the operation.
- D. If after replacing the load cell cable, the error still exists, replace the two connecting load cells (one at a time) to confirm the operation.

SCALE WILL NOT RETURN TO ZERO

SOLUTION:

- A. After ensuring the scale deck is clear of any buildup or debris, enter DIAGNOSTICS.
- B. The first screen displays the actual deadload that is on each load cell. If these values look correct, push the ZERO key to get a zero reading for each load cell.
- C. Make multiple passes with a loaded truck and observe which (if any) load cells do not return to zero. Small errors are normal as the deck may not return to exactly its previous position.
- D. If a load cell is not returning to zero, jack up the bridge at that load cell location and check for broken pivot plates, balls, or the hardened cup.
- E. Check for clearance from the corner stand to the main beam flanges. If a stand is not centered and is rubbing the bridge, it will cause zero errors.

SCALE IS UNSTABLE

SOLUTION:

- A. Go to the second diagnostics screen MINIMUM/MAXIMUM WEIGHTS and press ZERO.
- B. Observe the change in the output of the load cells for 10-15 minutes to identify a drifting load cell.

LOAD CELL OR SCALE COMMUNICATIONS PROBLEMS

SOLUTION:

- A. Go to the Diagnostics screen LOAD CELL COMMUNICATIONS ERRORS and observe the historical error counters for each load cell.
- B. Record these numbers.
- C. Press EXIT(?) to zero the counters on the 225D.

For the 825D, press C)lear to zero the counters.

NOTE: Some number of the communications errors are normal, however, they should all be approximately the same.

ISITE CONFIGURATION

225D iSite Configuration

The 225D will periodically send indicator, scale, and cell data to the Cardinal iSite Webserver for diagnostic logging. This information will be used by the server to determine if there are problems with the scale(s) that need to be addressed.

To access the ISITE IP CONFIG menu:

1. Press **SHIFT + RED_KEY** to enter SETUP/REVIEW.
2. Press **ENTER** once and **DOWN** twice to navigate to SETUP MENU #3.
3. Select **#9. ISITE IP CONFIG**

The SO# of the scale is used to match up the scale to the correct iSite dealer account. In many cases, DHCP may be used in which case setup is quite simple:

1. SO# = XXXXXX
2. DHCP = YES

If a static IP address is required (such as to address firewall issues) then set DHCP = NO and prompting will appear to manually set addresses:

1. SO# = XXXXXX
2. DHCP = NO
3. IP = XXX.XXX.XXX.XXX
4. SUBNET = XXX.XXX.XXX.XXX
5. GATEWAY = XXX.XXX.XXX.XXX

To confirm that iSite is working or to diagnose any errors in the connection there is an iSite status page in the diagnostics menu. Some of the information is quite technical but is present in case of a more complicated problem.

To Check the Status of the Last iSite Connection

1. From the main weight screen, go to the diagnostics menu by pressing **SHIFT + CELL_DIAG**.
2. Navigate with the **PREVIOUS/NEXT** soft keys to the page titled "ISITE STATUS OF LAST CONNECTION".

225D iSite Configuration, Cont.

To Check the Status of the Last iSite Connection, Cont.

```
ISITE STATUS OF LAST CONNECTION
IP = 10.1.3.109
ETHERNET DETECTED
WAITING FOR SOCKET INIT

HTTP RESP = 0

PREVIOUS      NEXT      EXIT
```

3. The following information is available:

- A. IP address (if available).
- B. Ethernet cable state – “ETHERNET DETECTED” or “ETHERNET NOT DETECTED”
- C. The status of the connection. The following statuses should occur in order while making a connection after bootup:
 - a. WAITING FOR SOCKET INIT
 - b. IP BINDING
 - c. DNS RESOLVING SERVER IP
 - d. COMM ESTABLISHED – OR—PORT CONNECT FAIL
- D. Once there is a connection to the webserver, the previous HTTP response will be displayed.
 - a. A good response is “HTTP RESP = 200 OKAY”
 - b. Any other response means there is a problem. Many issues are causing the SO# to not be entered in the indicator, “HTTP RESP = 404 CHECK SO# IN 225 SETUP”.

825D iSite Configuration

The 825D will periodically send indicator, scale, and cell data to the Cardinal iSite Webserver for diagnostic logging. This information will be used by the server to determine if there are problems with the scale(s) that need to be addressed.

With the **Scale 1 - Calibration Options** screen displayed, press the **6** key, or use the Navigation Keys to select (highlight) **6. DLC Diagnostics**, and then press the **ENTER** key.

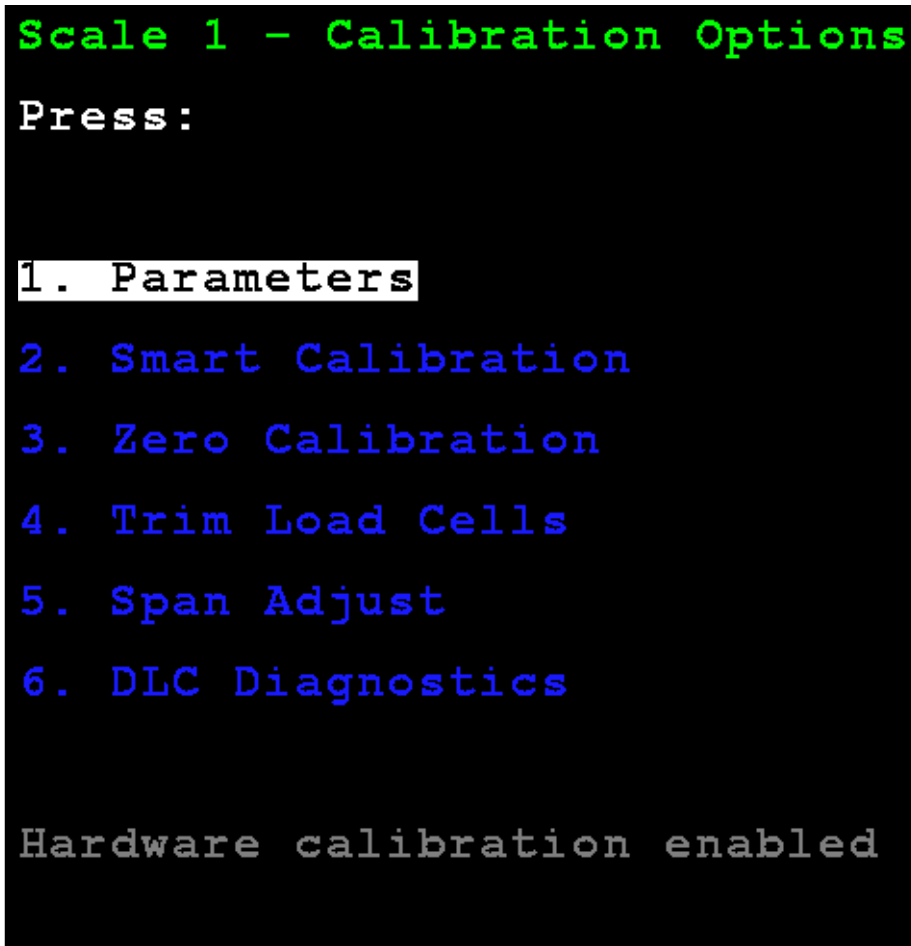

The display will change to the **Digital Load Cell Diagnostics Load Cell Weights** screen.

Press the **I** key to jump to the **iSite Status of Last Connection** screen.

825D iSite Configuration, Cont.

iSite Status of Last Connection

If **IP BINDING** message is displayed for a long time, it may indicate no network connection is present.

WAITING FOR SOCKET INIT

PORT CONNECT FAIL

COMM ESTABLISHED – successful connection

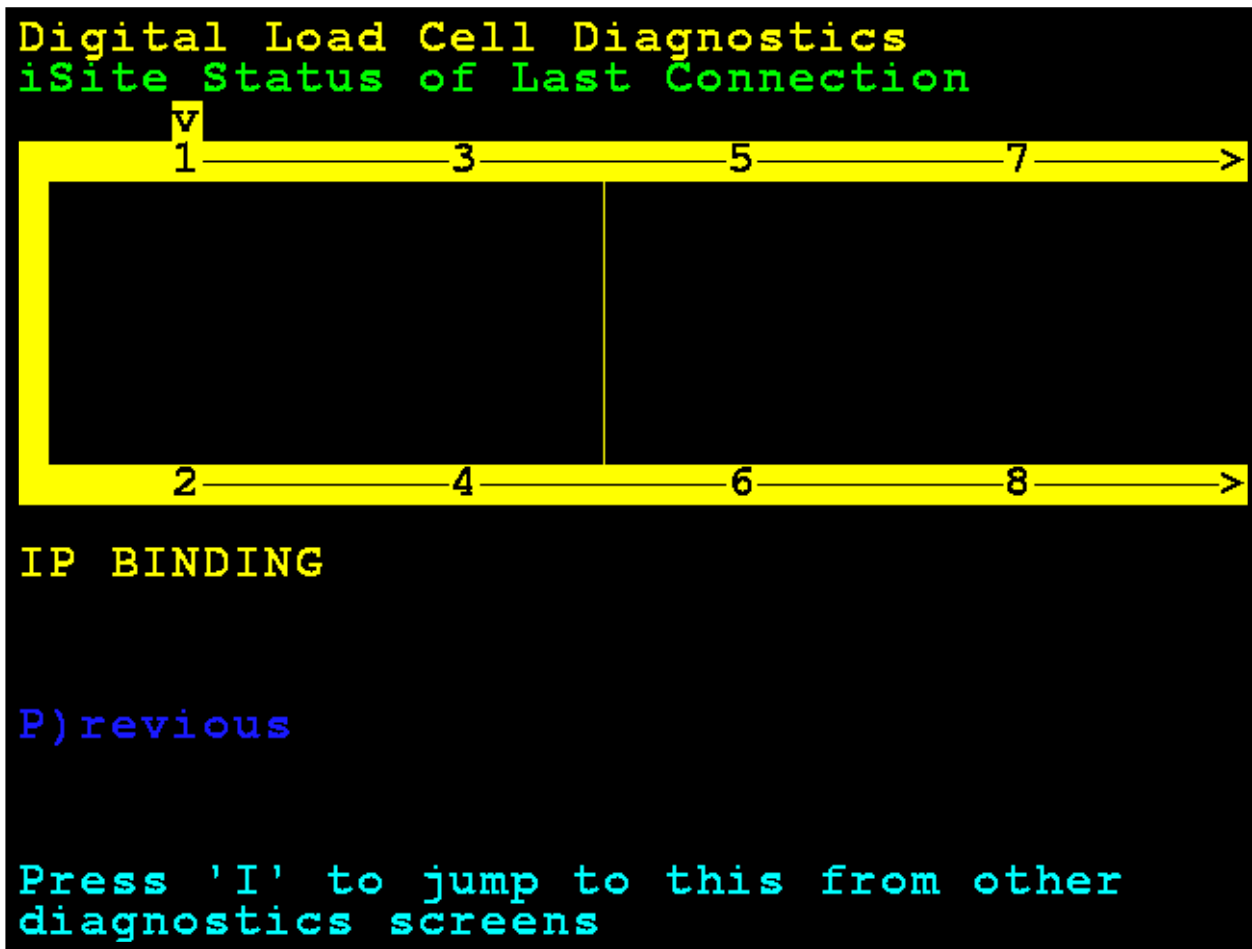

825D iSite Configuration, Cont.

Enter Valid SO Identifier for iSite

Make sure a valid SO identifier is entered for iSite.

```
COMM ESTABLISHED
CHECK SO# IN 825 SETUP
Response 2019-02-18 20:12:48 GMT

P)revious

Press 'I' to jump to this from other
diagnostics screens
```

Successful Comm Establish for iSite

The 825D screen will display **OKAY** when a successful comm has been established.

```
COMM ESTABLISHED
OKAY
Response 2019-02-18 20:14:58 GMT

P)revious

Press 'I' to jump to this from other
diagnostics screens
```

PARTS IDENTIFICATION

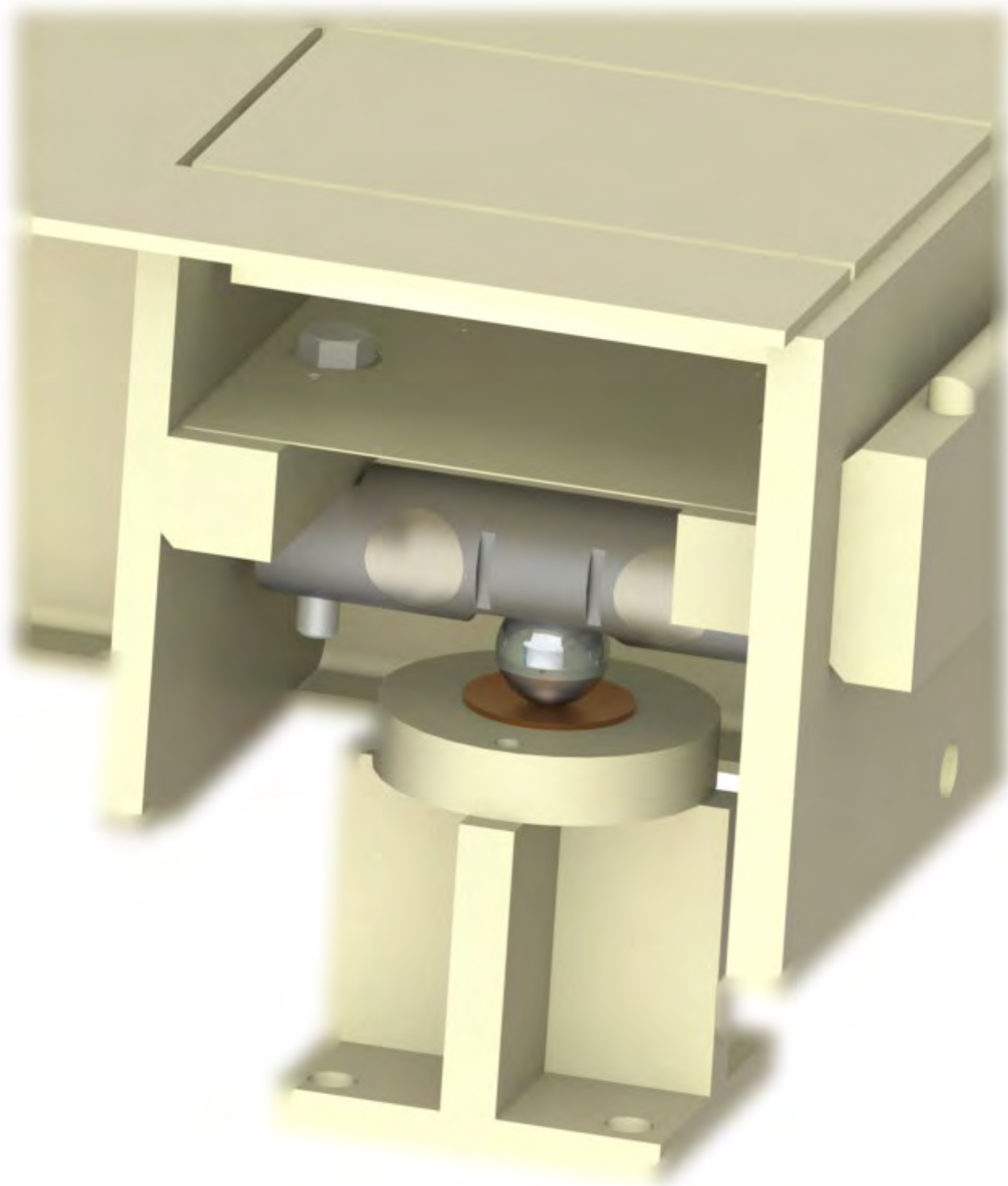

Load Cell Top View Detail

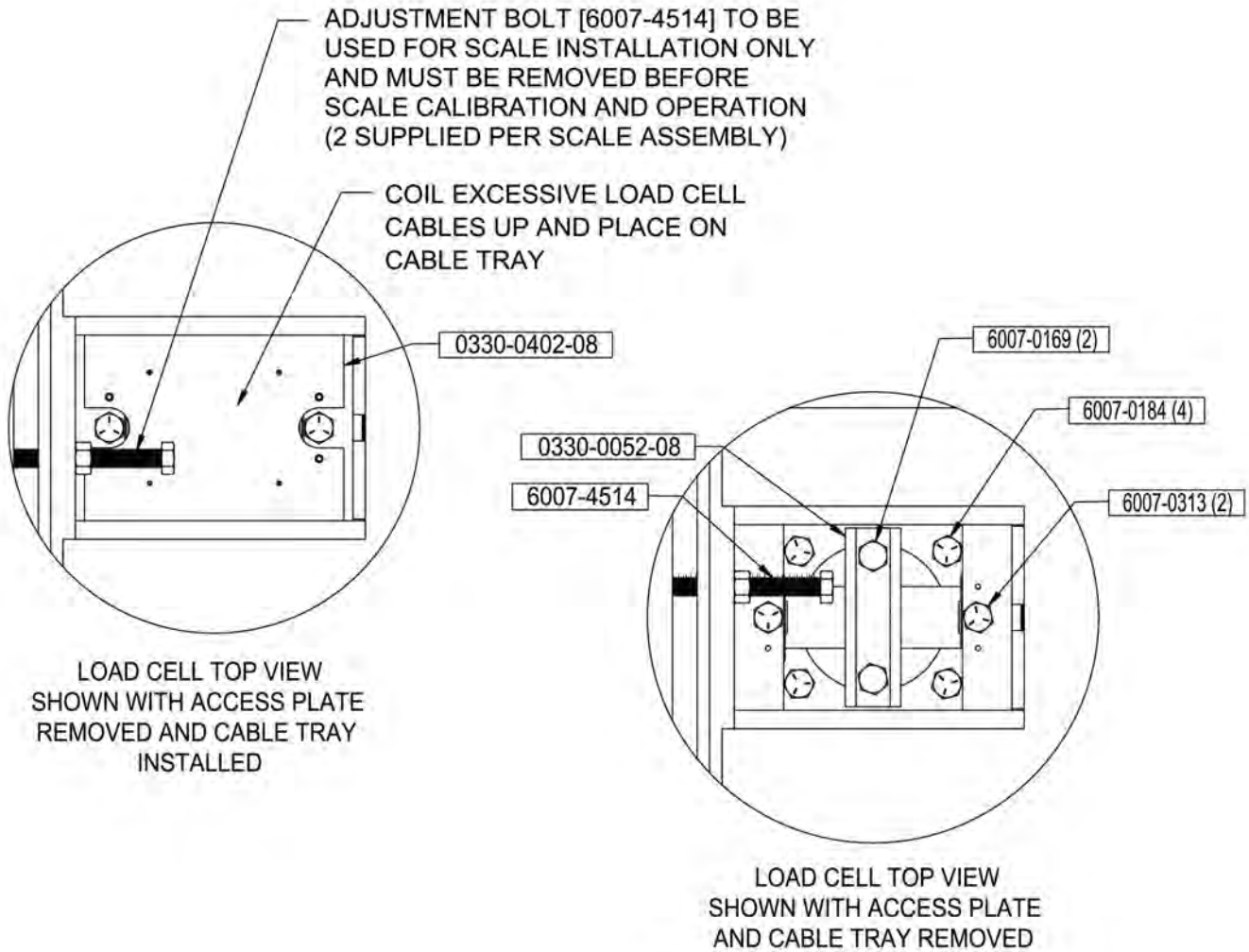

NOTE: Quantity shown is for a 70' x 11' Steel Deck Scale

ITEM	QTY.	DESCRIPTION
0330-0402-08	8	CABLE TRAY
6007-4514	2	BLT HEX HD 3/4-10x6" GRADE 5 ZP TAP BOLT
0330-0052-08	8	SHIPPING BRACKET
6007-0169	16	BLT HEX HD 1/2-13x6" UNC-2A GRADE 5 Z/P
6007-0184	32	BLT CONCRETE ANCHOR 3/4" x 7"
6007-0313	16	BLT HEX HD 3/4-10x4" UNC-2A GRADE 5 ZP

Load Cell Stand and Parts Detail

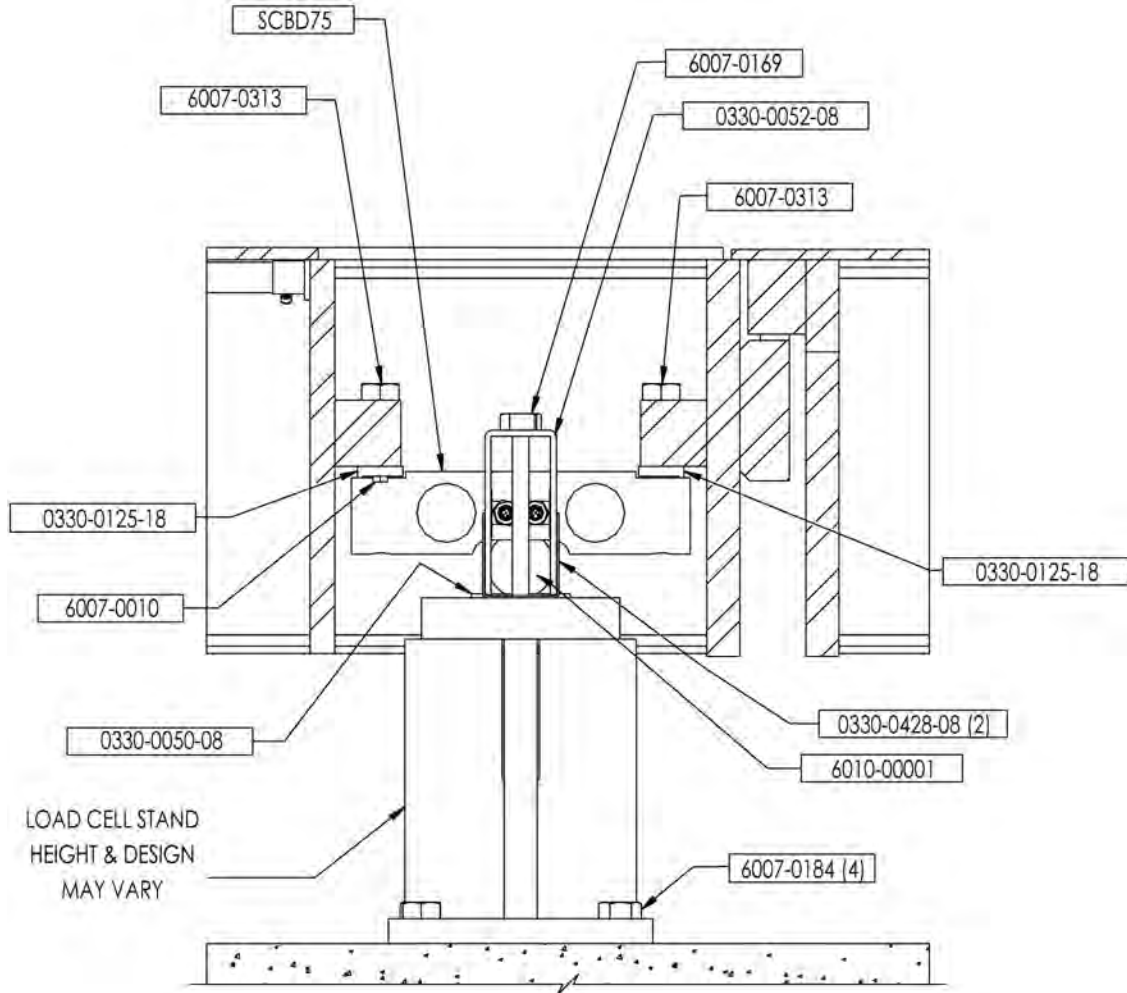

NOTE: Quantity shown is for a 70' x 11' Steel Deck Scale

ITEM	QTY.	DESCRIPTION
SCBD75	8	LOAD CELL, DIGITAL, DOUBLE-ENDED SHEAR BEAM, 34,000 KG/75,000 LB, STAINLESS STEEL
6007-0169	16	BLT HEX HD 1/2-13x6" UNC-2A GRADE 5 Z/P
0330-0052-08	8	SHIPPING BRACKET
0330-0428-08	16	LOWER SHIPPING BRACKET
6007-0313	16	BLT HEX HD 3/4-10x4" UNC-2A GRADE 5 ZP
0330-0125-18	16	PIVOT PLATE
6007-0010	16	BLT HEX HD 1/4-20x3/4" Z/P
6010-00001	8	BALL BEARING, 2.0 DIA GRADE 1000, 52100 CHROME
0330-0050-08	8	BOTTOM CUP
0331-0107-0A	8	5" LOAD CELL STAND WELDMENT (LOAD CELL STAND HEIGHT & DESIGN MAY VARY)
6007-0184	32	BLT CONCRETE ANCHOR 3/4" x 7"

Load Cell Interconnect Cables

NOTE: Quantity shown is for a 70' x 11' Steel Deck Scale

ITEM	QTY.	DESCRIPTION
0330-0065-08	2	LOAD CELL INTERCONNECT CABLE, 15' (4572mm), 22AWG
0330-0066-08	5	LOAD CELL INTERCONNECT CABLE, 27', (8230mm), 22AWG
0330-0067-08	1	LOAD CELL END TERMINATOR
3502-0681-0A	1	BAGGED CONNECTOR AND INSTRUCTION SHEET (INCLUDES 5-PIN ACTUATION LEVER-TYPE CONNECTOR, 6610-1308)
6540-1618	8	CAP VINYL .375 ID x .50" LONG, BLACK
6540-1619	7	CAP VINYL FOR 1/2"-9/16" OD x 3/4" LONG, BLACK
6600-1237	1	OPTION: SURGE SUPPRESSOR, 120V AC

Components Included in 3502-0681-0A

6610-1308	1	CONN 05 PIN CIRCULAR, M12 A-CODED FEMALE CONNECTOR, ACTUATION LEVER, 4 - 8mm CABLE O.D. <i>(For Homerun Cable)</i>
6050-3056	1	DIELECTRIC GREASE, 0.5 OUNCE TUBE
0330-0408-0M	1	SMARTCELL DIGITAL LOAD CELL HOMERUN CABLE CONNECTOR INSTALLATION INSTRUCTIONS

Load Cell Shims

NOTE: Quantity shown is for a 70' x 11' Steel Deck Scale

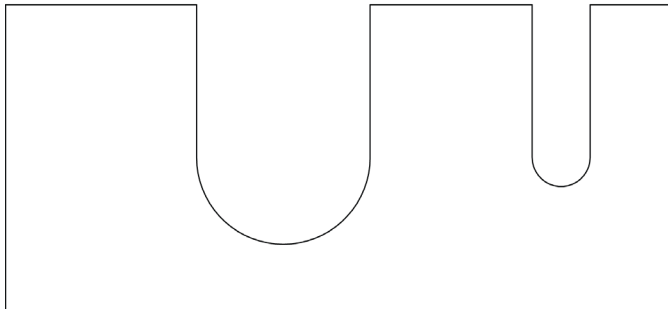

ITEM	QTY.	DESCRIPTION
0330-0148-08	8	7 GA. (3/16") LOAD CELL SHIM
0330-0149-08	8	10 GA. (1/8") LOAD CELL SHIM

Included Grounding Components

ITEM	QTY.	DESCRIPTION
6980-0054	1	GROUND ROD .625" DIAMETER X 10 FEET.
6980-0036	1	GROUND CABLE, 1 1/2" FLAT BRAID #3 AWG
6980-0035	1	WIRE #10 AWG STRANDED, GREEN
6610-5023	2	GROUNDING CLAMP

Optional Lifting Lug

Lifting lugs are available for steel deck scales for the lifting of scale modules. Note that the lifting lugs are shipped on the last module loaded on the truck at the factory.



Modifications at the factory to the steel deck are required to attach lifting lugs. Lifting lugs cannot be used on an unmodified steel deck. If using lifting lugs is desired, the scale order must clearly state that liftings lugs are to be used and the lifting lugs ordered with the scale.

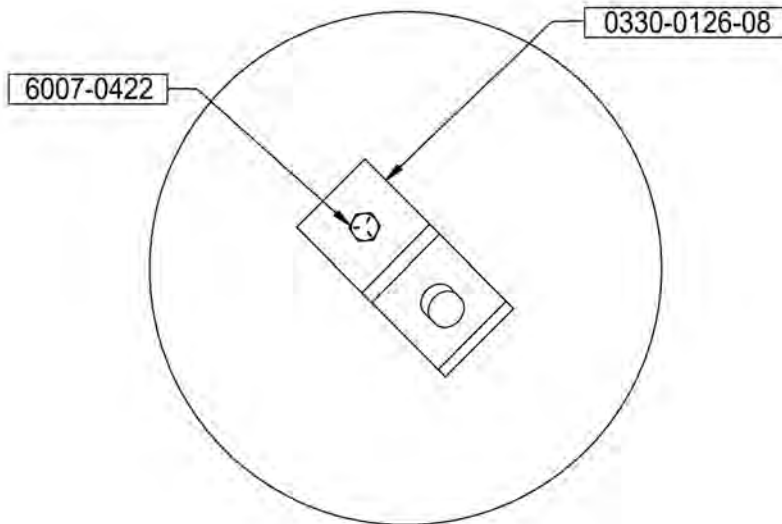

ITEM	QTY.	DESCRIPTION
6007-0422	4	HEX HEAD BOLT, 3/4"-10 X 3" GRADE 8 Z/P
0330-0126-08	4	LIFTING LUG, HR PL 3/4" X 4" X 8 11/16"

Rodent Guard Sub-Assemblies for 12-inch Beam Steel Deck

NOTE: Quantities listed are for one Load Cell

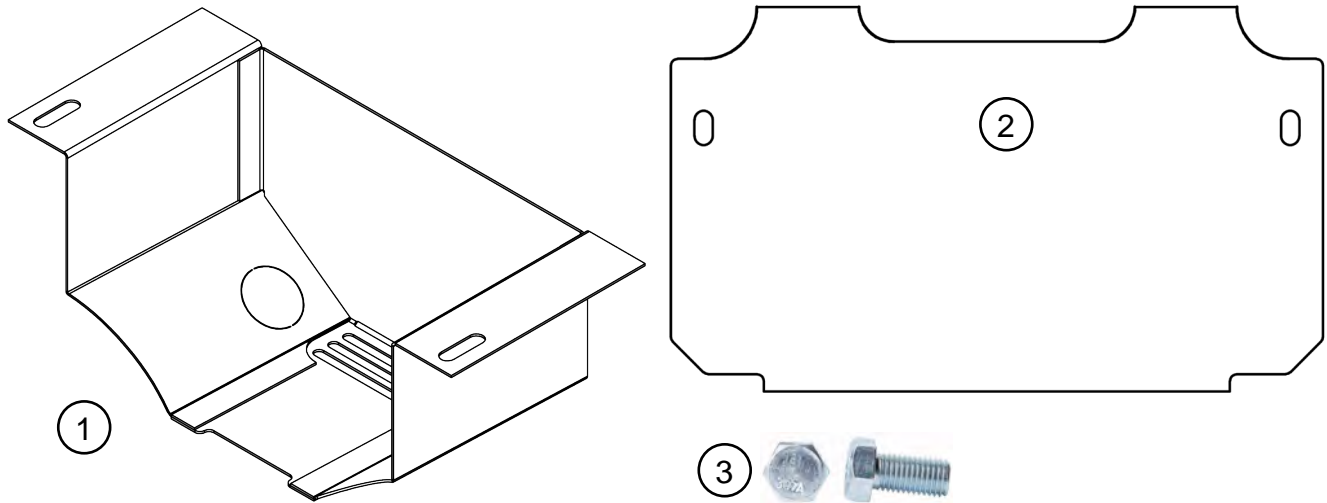

Rodent Guard 12-inch Beam Steel Deck Cross Section View

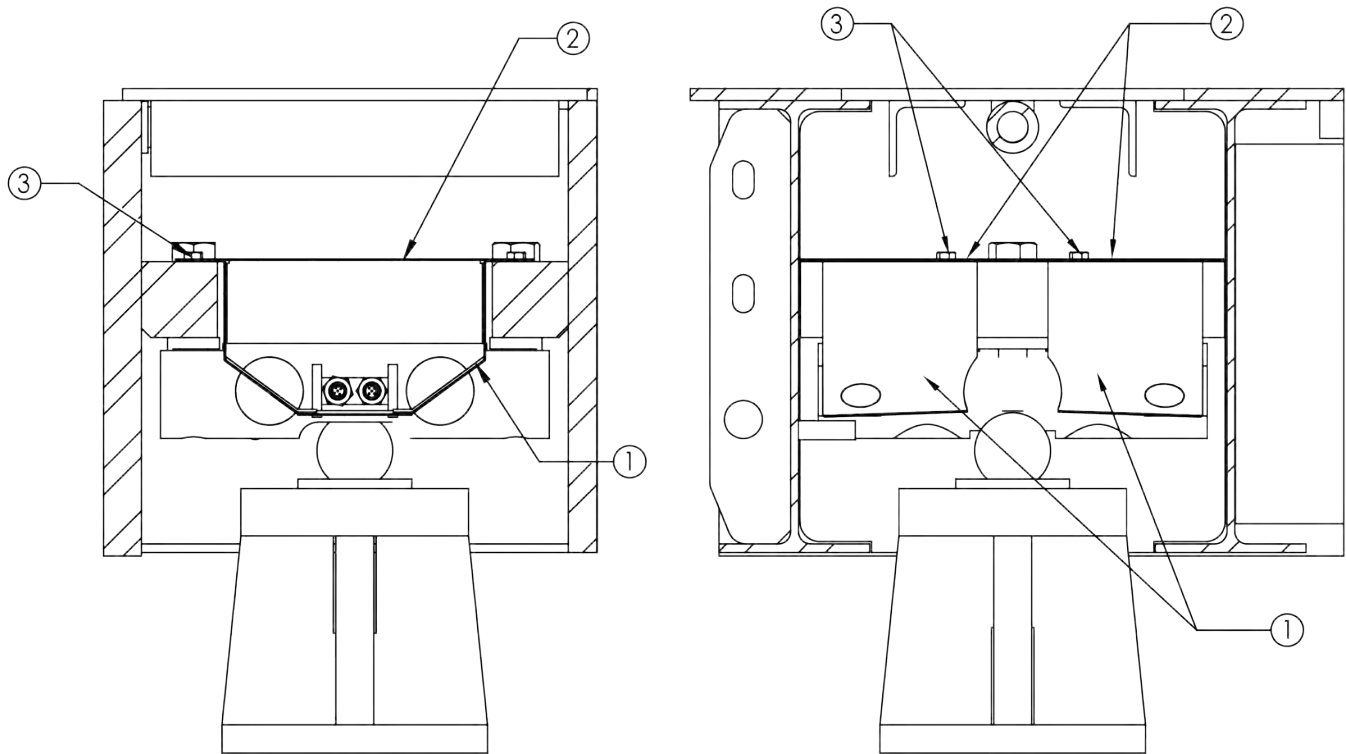

Item	Qty.	Part Number	Description
1	2	0330-2569-0A	LC GUARD WELDMENT, 12-INCH BEAM
2	2	0330-2570-08	LC GUARD COVER
3	4	6007-0010	BLT HEX HD 1/4-20 X 3/4 INCH Z/P

Rodent Guard Sub-Assemblies for 8-inch Beam Concrete Deck

NOTE: Quantities listed are for one Load Cell

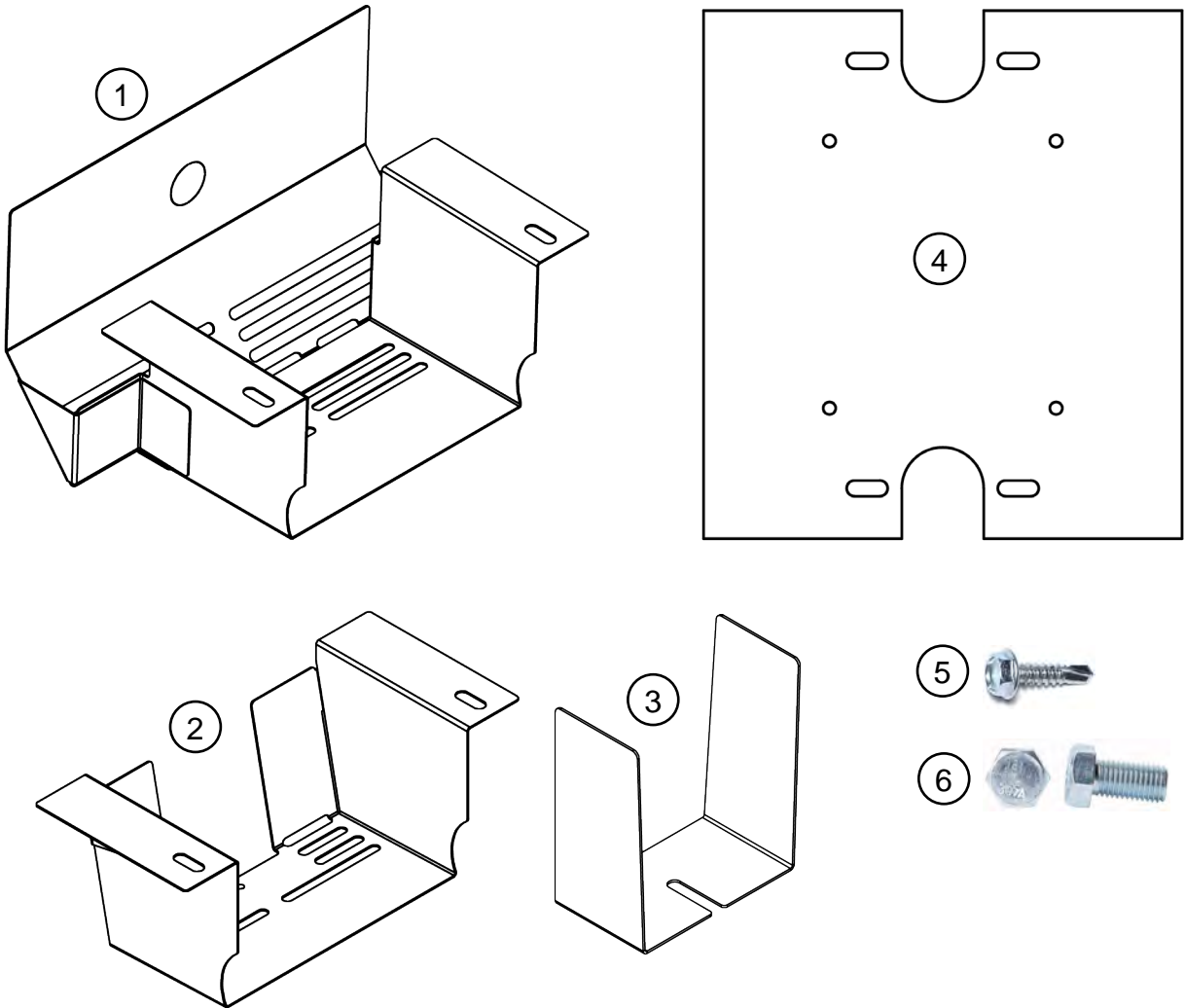

Item	Qty.	Part Number	Description
1	1	0330-2736-0A	8-INCH CONCRETE DECK OUTER RODENT GUARD
2	1	0330-2738-08	CONCRETE DECK INNER RODENT GUARD
3	1	0330-2739-08	CONCRETE DECK INNER RODENT GUARD PLATE
4	1	0330-2901-08	CONCRETE DECK CABLE TRAY
5	1	6021-0981	#10 X .75 IN HEX-HEAD, INDENTED HEX WASHER, SELF-TAPPING SCREW
6	4	6007-0010	BOLT HEX-HEAD 1/4-20 X 3/4 IN ZINC PLATED

Rodent Guard Sub-Assemblies for 10-inch Beam Concrete Deck

NOTE: Quantities listed are for one Load Cell

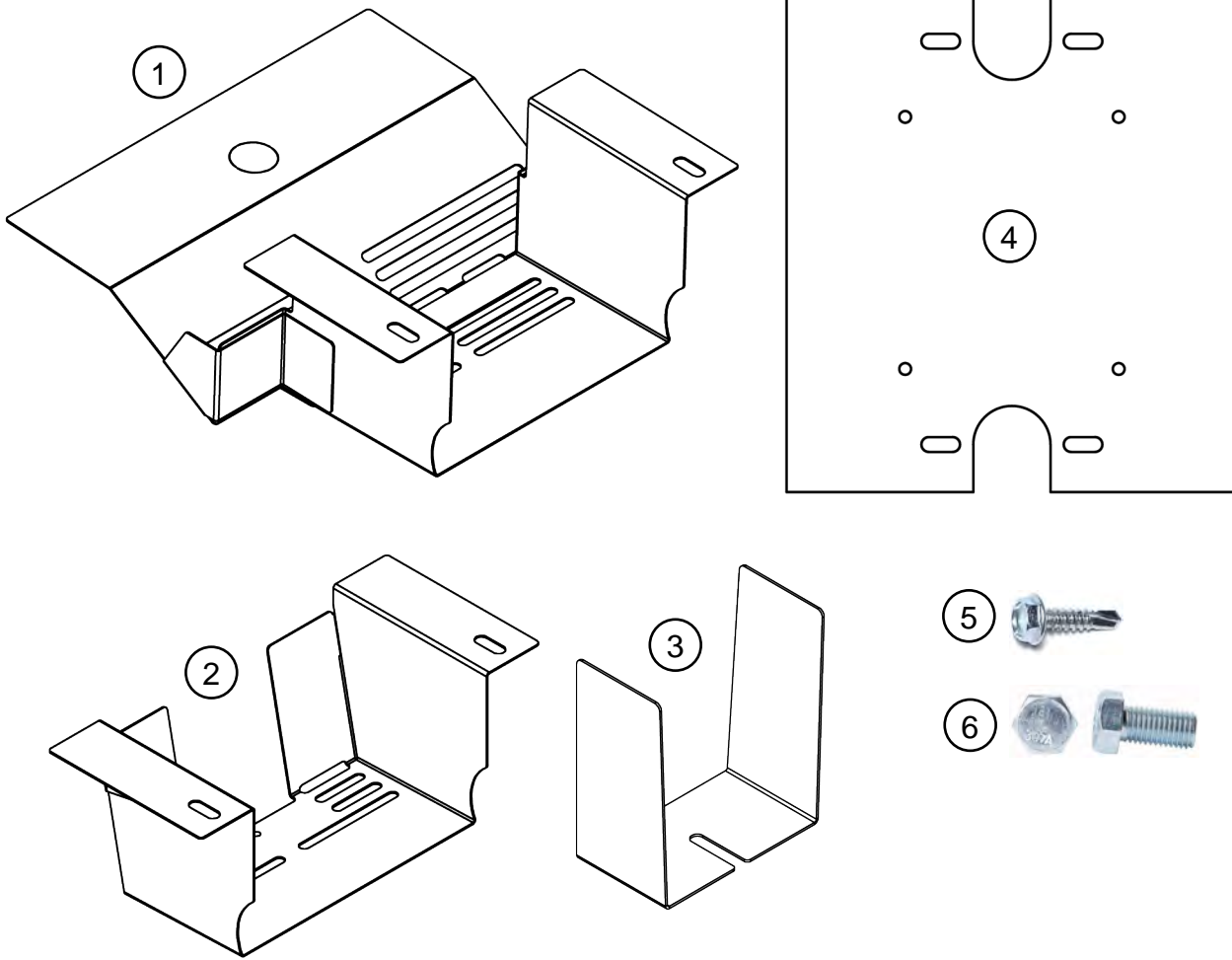

Item	Qty.	Part Number	Description
1	1	0330-2737-0A	10 INCH CONCRETE DECK OUTER RODENT GUARD
2	1	0330-2738-08	CONCRETE DECK INNER RODENT GUARD
3	1	0330-2739-08	CONCRETE DECK INNER RODENT GUARD PLATE
4	1	0330-2901-08	CONCRETE DECK CABLE TRAY
5	1	6021-0981	#10 X .75 IN HEX-HEAD, INDENTED HEX WASHER, SELF-TAPPING SCREW
6	4	6007-0010	BOLT HEX-HEAD 1/4-20 X 3/4 IN ZINC PLATED

Rodent Guard 8-inch and 10-inch Beam Concrete Deck Cross Section View

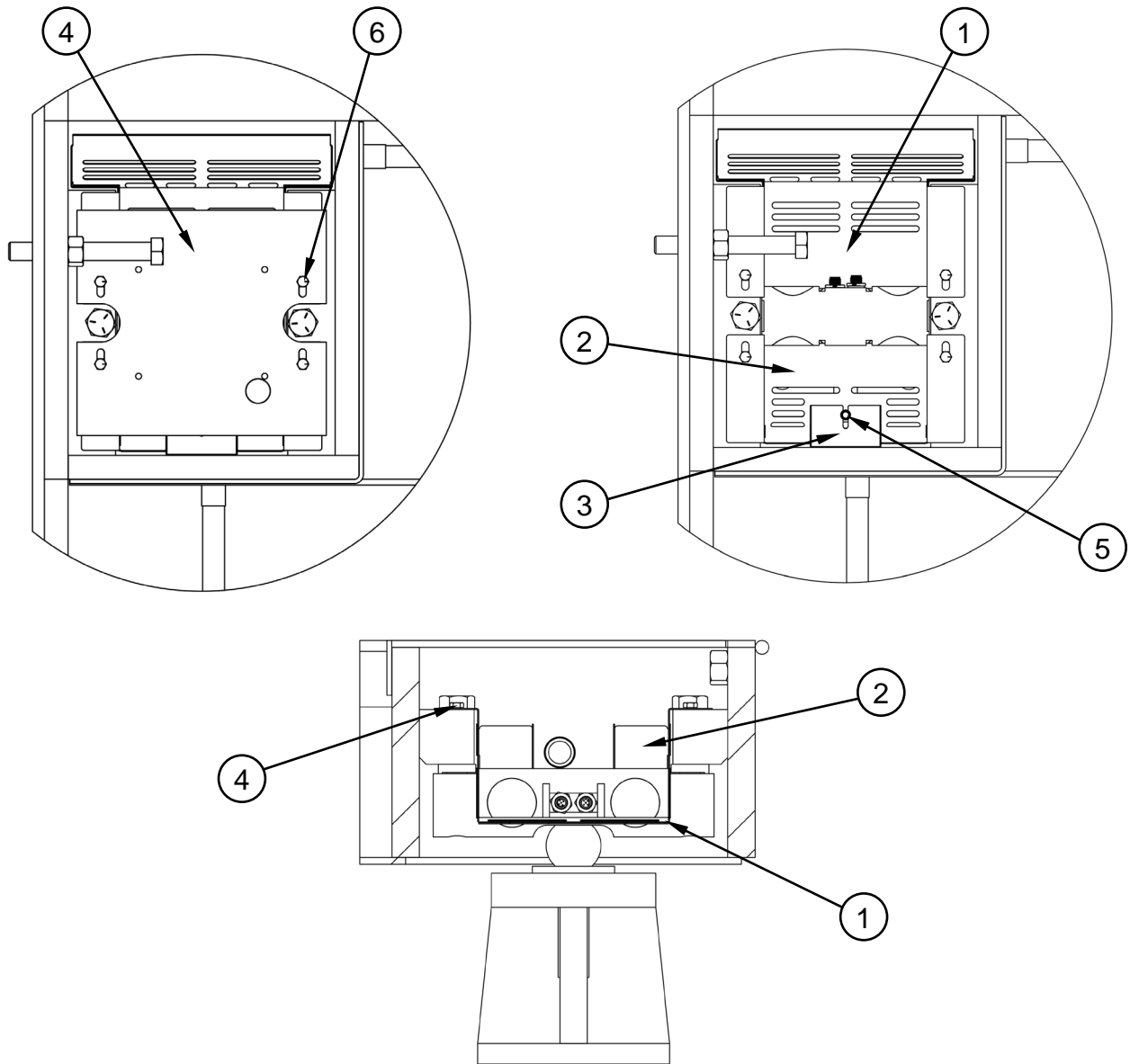

Item	Qty.	Part Number	Description
1	1	0330-2736-0A	8-INCH CONCRETE DECK OUTER RODENT GUARD
1	1	0330-2737-0A	10-INCH CONCRETE DECK OUTER RODENT GUARD
2	1	0330-2738-08	CONCRETE DECK INNER RODENT GUARD
3	1	0330-2739-08	CONCRETE DECK INNER RODENT GUARD PLATE
4	1	0330-2901-08	CONCRETE DECK CABLE TRAY
5	1	6021-0981	#10 X .75 IN HEX-HEAD, INDENTED HEX WASHER, SELF-TAPPING SCREW
6	4	6007-0010	BOLT HEX-HEAD 1/4-20 X 3/4 IN ZINC PLATED



STATEMENT OF LIMITED WARRANTY

WARRANTY TERMS

Cardinal Scale Manufacturing Company warrants the equipment we manufacture against defects in material and workmanship. The length and terms and conditions of these warranties vary with the type of product and are summarized below:

PRODUCT TYPE	TERM	MATERIAL AND WORKMANSHIP	LIGHTNING DAMAGE See note 9	WATER DAMAGE See note 7	CORROSION See note 4	ON-SITE LABOR	LIMITATIONS AND REQUIREMENTS
WEIGHT INDICATORS	90 DAY REPLACEMENT ----- 1 YEAR PARTS	YES	YES	YES	YES	NO	1, 2, 3, 5, 6 A, B, C, D
LOAD CELLS (Excluding Hydraulic)	1 YEAR	YES	YES	YES	YES	NO	1, 2, 3, 5, 6 A, B, C, D
HYDRAULIC LOAD CELLS (When purchased with Guardian Vehicle Scale)	LIFE	YES	YES	YES	YES	90 DAYS	1, 5, 6, 8 A, B, C, D
HYDRAULIC LOAD CELLS (When purchased separately)	10 YEARS	YES	YES	YES	YES	NO	1, 5, 6, 8, 9 A, B, C, D
VEHICLE SCALE (Deck and Below Excl. PSC Series)	5 YEARS	YES	YES	YES	YES	90 DAYS	1, 2, 3, 5, 6 A, B, C, D, E
PSC and LSC SCALE STRUCTURES (Deck and Below)	3 YEARS	YES	YES	YES	YES	90 DAYS	1, 2, 3, 5, 6, 11 A, B, C, D
GUARDIAN FLOOR SCALES	10 YEARS	YES	YES	YES	YES	NO	1, 2, 3, 5, 6, 9, 10 A, B, C, D
ALL OTHER CARDINAL PRODUCTS	1 YEAR	YES	YES	YES	YES	NO	1, 2, 5, 6 A, B, C, D, E
REPLACEMENT PARTS	90 DAYS	YES	YES	YES	YES	NO	1, 2, 4, 5, 6 A, B, C, D
IN-MOTION and 760 SERIES VEHICLE SCALES	1 YEAR	YES	YES	YES	YES	90 DAYS	1, 2, 5, 6 A, B, C, D
SOFTWARE	90 DAYS	YES	N/A	N/A	N/A	NO	1, 6 B, C, D
CONVEYOR BELT SCALES (Including Belt-Way)	1 YEAR	YES	YES	YES	YES	NO	1, 2, 3, 5, 6 A, B, C, D, E, F

APPLICABLE LIMITATIONS AND REQUIREMENTS

1. This warranty applies only to the original purchaser. The warranty does not apply to equipment that has been tampered with, defaced, damaged, or had repairs or modifications not authorized by Cardinal or has had the serial number altered, defaced or removed.
2. This warranty is not applicable to equipment that has not been grounded in accordance with Cardinal's recommendations.
3. This equipment must be installed and continuously maintained by an authorized Cardinal / Belt-Way dealer.
4. Applies only to components constructed from stainless steel.
5. This warranty does not apply to equipment damaged in transit. Claims for such damage must be made with the responsible freight carrier in accordance with freight carrier regulations.
6. Warranty term begins with date of shipment from Cardinal.
7. Only if device is rated NEMA 4 or better or IP equivalent.
8. Lifetime warranty applies to damages resulting from water, lightning, and voltage transients and applies only to the hydraulic load cell structure itself (does not include pressure transducers, rubber seals, o-rings, and associated wiring).
9. 10 Year prorated warranty on hydraulic load cells.
10. 1 Year warranty for scale structure.
11. PSC models' warranty coverage applies only to agricultural installations on farms up to 3,000 acres (LSC models not limited in this manner).
12. Load cell kits MUST be installed in accordance with Cardinal Scale instructions. Failure to follow these instructions will void the warranty.

EXCLUSIONS

- A.) This warranty does not include replacement of consumable or expendable parts. The warranty does not apply to any item that has been damaged due to unusual wear, abuse, improper line voltage, overloading, theft, fire, water, prolonged storage or exposure while in purchaser's possession or acts of God unless otherwise stated herein.
- B.) This warranty does not apply to peripheral equipment not manufactured by Cardinal. This equipment will normally be covered by the equipment manufacturer's warranty.
- C.) This warranty sets forth the extent of our liability for breach of any warranty or deficiency in connection with the sale or use of our product. Cardinal will not be liable for consequential damages of any nature, including but not limited to loss of profit, delays or expenses, whether based on tort or contract. Cardinal reserves the right to incorporate improvements in material and design without notice and is not obligated to incorporate said improvements in equipment previously manufactured.
- D.) This warranty is in lieu of all other warranties expressed or implied including any warranty that extends beyond the description of the product including any warranty of merchantability or fitness for a particular purpose. This warranty covers only those Cardinal products installed in the forty-eight contiguous United States and Canada.
- E.) This warranty does not cover paint coatings due to the variety of environmental conditions.
- F.) Do not cut load cell cables on load cells returned for credit or warranty replacement. Cutting the cable will void the warranty.
- G.) Software is warranted only for performance of the functions listed in the software manual and/or the Cardinal proposal.
- H.) The software warranty does not cover hardware. Warranties on hardware are provided from the hardware vendor only.
- I.) The software warranty does not cover interfacing issues to non-Cardinal supplied hardware.
- J.) The software warranty does not include automatic software upgrades unless purchased separately.



Cardinal Scale Mfg. Co.

102 E. Daugherty, Webb City, MO 64870 USA

Ph: 417-673-4631 or 1-800-641-2008

Fax: 417-673-2153

www.cardinalscale.com

Technical Support: 1-866-254-8261

E-mail: tech@cardet.com

Printed in USA

0330-0153-0M Rev L 03/23