



CARDINAL®

SCA Series

Compression Weighing Load Cells

- **Capacity: 120,000 lb/54,430 kg**
- **Environmentally-sealed (IP68)**
- **Stainless steel construction**
- **35'/10m integral shielded cable**

These heavy-capacity compression load cells are ideal for multi-cell applications including truck scales, railroad track scales, and heavy-duty tank/hopper weighing systems.

The SCA load cells are fabricated from stainless steel to provide the ultimate in protection when caustic, corrosive or wet environments are encountered.

Load cells are environmentally-sealed for absolute water protection. Each load cell is furnished with stainless steel load buttons on each end, and an integral multi-conductor cable secured by a strain relief seal.



MECHANICAL DATA

Rated Capacity, (R.C.) E_{max}	120,000 lb / 54,430 kg
Minimum Dead Load	1,000 lb / 454 kg
Safe Load Limit	150% R.C.
Ultimate Load	300% R.C.
Deflection at R.C.	0.01 in / 0.33 mm
Net Weight	11 lb / 5 kg

ELECTRICAL DATA

Rated Output	2mV/V
Excitation Voltage, Minimum	10 VDC
Excitation Voltage, Maximum	15 VDC
Cable Length	35 ft / 10 m
Terminal Resistance	
Excitation	1,150 ± 60 ohms
Signal	1,050 ± 15 ohms
Zero Load Output	>2% R.C.
Insulation Resistance	>5,000 megohms at 50 VDC

CERTIFICATE DATA

ISSUING BODY	NTEP	OIML
Certificate Number	89-042A4	R60/1991-DK-97.04 rev 1
Accuracy Class	IIIIL	C3
Maximum Number of Load Cell Intervals, n_{max}	10,000	3,000
Single/Multiple	M	
Humidity Symbol		CH
Minimum Load Cell Verification Interval V_{min}	3.6 lb/1.63 kg	2.4 lb/1.09 kg

ENVIRONMENTAL DATA

Temperature Compensation Range	-10 to +40°C
Operating Temperature Range	-29 to +93°C
Construction & Protection Code	CP-67 HU, IP68
Barometric Pressure Effect on Zero Load Output	<1 v (min)/1kPa

SCALE

SCA

SCA Series

Compression Weighing Load Cells

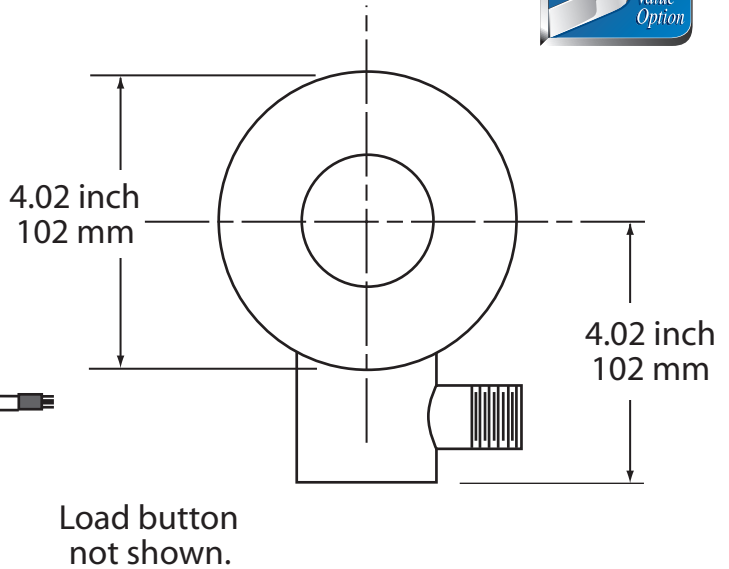
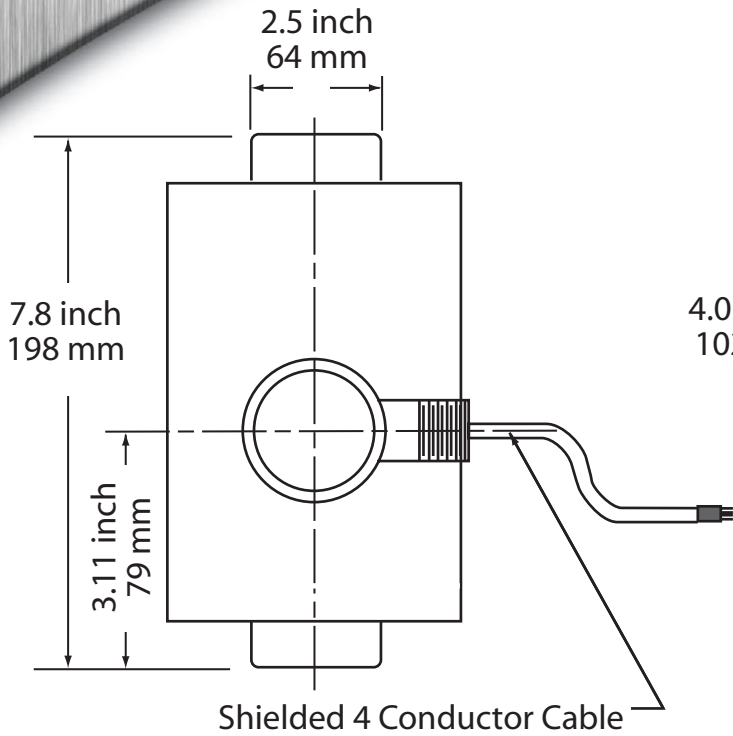

ELECTRICAL INFORMATION

- Green + excitation
- Black - excitation
- Shield - Yellow
- White - signal
- Red + signal

State-of-the-Art Load Cell Manufacturing Facility ISO 9001 Quality Environment



CERTIFICATIONS

The Model SCA Load Cell meets or exceeds Class III, 10,000 division accuracy requirements in accordance with NIST Handbook 44. A Certificate of Conformance (Number 89-042A4) has been issued under the National Type Evaluation Program (NTEP) of the National Conference on Weights and Measures.



VCAP CERTIFIED

Cardinal Scale has been found to fully comply with the Verified Conformity Assessment Program (VCAP) administered by the National Type Evaluation Program (NTEP) of the National Conference on Weights and Measures (NCWM).

Cardinal Scale reserves the right to improve, enhance or modify features and specifications without prior notice. All registered trademarks are the property of their respective owners.



SOLD BY:



102 East Daugherty St., Webb City, MO 64870 USA
Toll-Free: (800) 441-4237 E-mail: cardinal@cardet.com
www.CardinalScale.com