



CARDINAL®



**The GUARDIAN®
Hydraulic Floor Stand
Tank/Hopper Assemblies
Owner's Manual**

Technical Support: Ph: 866-254-8261 • tech@cardet.com

TABLE OF CONTENTS

Introduction	Page 1
Site Preparation	Page 1
Installation	Page 2
Gauging SST Hydraulic Load Cells	Page 5
Gauging H2.5K and H5K Hydraulic Load Cells	Page 7
Final Assembly	Page 9
Indicator Installation	Page 11
Conformal Coating	Page 13
Maintenance	Page 13
Troubleshooting	Page 14
SST Hydraulic Load Cells	Page 14
H2.5K and H5K Hydraulic Load Cells	Page 15
PTG-3K Transducer Shooting	Page 16
Recommended Sealing Procedure	Page 17
Parts Identification	
H2.5K Load Cell Assembly	Page 18
H2.5K Load Cell Stand	Page 20
(HBC2.5, Mild Steel and HBCS2.5, Stainless Steel)	
H5K Load Cell Assembly	Page 24
H5K Load Cell Stand	Page 26
(HBC5, Mild Steel and HBCS5, Stainless Steel)	
SST10 Load Cell Assembly	Page 30
SST10 Load Cell Stand	Page 32
(HBC10, Mild Steel and HBCS10, Stainless Steel)	
SST25 Load Cell Assembly	Page 36
SST25 Load Cell Stand	Page 38
(HBC25, Mild Steel and HBCS25, Stainless Steel)	
SST50 Load Cell Assembly	Page 42
SST50 Load Cell Support Assembly	Page 44
SST75 Load Cell Assembly	Page 46
SST75 Load Cell Support Assembly	Page 48
SST100 Load Cell Assembly	Page 50
SST100 Load Cell Support Assembly	Page 52
3 & 4-Cell Totalizer Enclosure	Page 54
Cell Output Calibration Worksheet	Page 58

PRECAUTIONS

Before using this product, read this manual and pay special attention to all "NOTIFICATION" symbols:



IMPORTANT



**ELECTRICAL
WARNING**



**STATIC
SENSITIVE**

INTRODUCTION

The Guardian® System is a unique hydraulic based weighing system that utilizes Stainless Steel hydraulic load cells as a load receiving element. The load cells are coupled by copper or stainless steel tubing to a totalizer enclosure. The totalizer enclosure contains a simple manifold assembly and a Cardinal PTG-3K Pressure Transducer for each load cell. The Pressure transducers convert the hydraulic pressure generated by the load cell to an analog signal that is easily trimmed and summed.

The Guardian® has no electronic components at the scale. All components at the scale are highly resistant to water, moisture, lightning damage, and vibration.



IMPORTANT! This manual must be used in conjunction with certified drawings of the particular weighing system being installed. *In case of conflict, the certified drawings will govern.* We recommend that you read this manual in its entirety before starting the installation.

SITE PREPARATION

Site preparation is consistent with any other scale installation. Conduit, if required, should be stubbed up at each load cell stand and run to the location of the totalizer enclosure. Any deviation from this should be noted since extra tubing may be required. Tubing length may not exceed 125 feet from the load cell to the totalizer, and no splices are allowed. Consideration should be given to avoid tight radius bends in the conduit that would make it difficult to pull the tubes to the totalizer enclosure. The totalizer enclosure should be located in a protected area close to the scale and the indicator cable run in conduit to the weight indicator if long tube runs need to be avoided. The totalizer enclosure may be located near the weight indicator if it is convenient to the scale.

INSTALLATION

In most installations it is advisable to locate and install the cells before the vessel or weighbridge is set in place. If the cell stand assemblies are installed with the vessel or weighbridge in place, extreme care should be taken to ensure that the stability of the vessel or weighbridge is maintained during installation of the load cell stands.

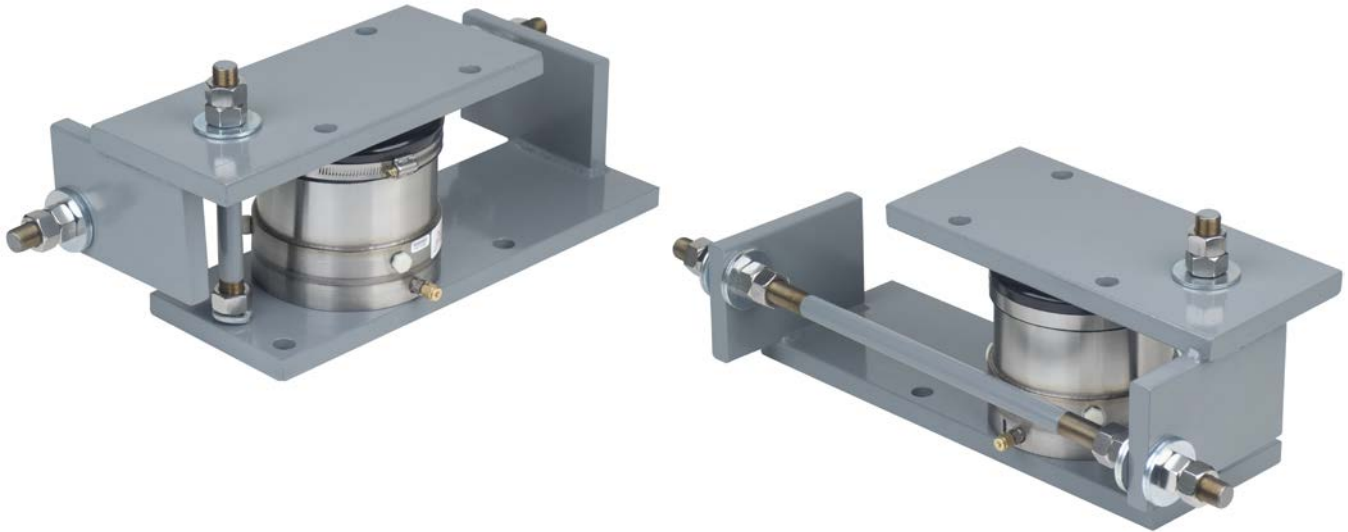

Figure No. 1 – Load Cell and Stand



Figure No. 2 – 3 & 4-Cell Totalizer

INSTALLATION, CONT.

Next, mount the totalizer enclosure on a wall as close to the digital weight indicator as possible. The totalizer enclosure should be mounted with at least 24 inches of clearance below it to allow room to connect the hydraulic tubes running from the cells to the bulkhead fittings. The 2 inch conduit from the scale should be stubbed up directly under the left side of the totalizer enclosure for the easiest installation. The totalizer should be located such that it is exposed to the same temperatures as the load cells. This ensures the proper operation of the temperature compensation circuits.

After the cells and the totalizer enclosure have been located, the hydraulic tubes must be cut to length and installed. Always start with the longest runs first and be aware that the drops from some of the longer runs may be used for shorter runs.



Be sure to leave a loop of tube at each load cell so that the cell can be moved a bit if necessary and also to allow a tube to be cut off and a new ferrule set installed if necessary. **NEVER** attach the tube to the scale weighbridge as the vibration will lead to fatigue and failure of the tube to load cell connection.

1. Using a sharp tube cutter, cut about one inch off of the end of each tube.
2. Cut only half way through the tube then gently bend the tube back and forth to finish the cut. This keeps the inside diameter of the tube from collapsing when the cutter breaks through the tube wall. Use a jeweler's file to remove any burrs from the end of the tube.
3. Place the nut and inner and outer ferrule over the tube and then assemble it finger tight onto the load cell or totalizer fitting.
4. Mark the nut so that you can tell where you began tightening the fitting and tighten $\frac{3}{4}$ to 1 turn.
5. Swagelok makes a simple gage to check the connection, so that if it will slide in between the fitting and nut, it needs tightend more.
6. If you must remove a fitting, they recommend you mark the nut and fitting so that when you reassemble the connection you go back to exactly the same place, and then an additional $\frac{1}{8}$ to $\frac{1}{4}$ turn.



Figure No. 3 – Swagelok Gap Inspection Gauge

INSTALLATION, CONT.

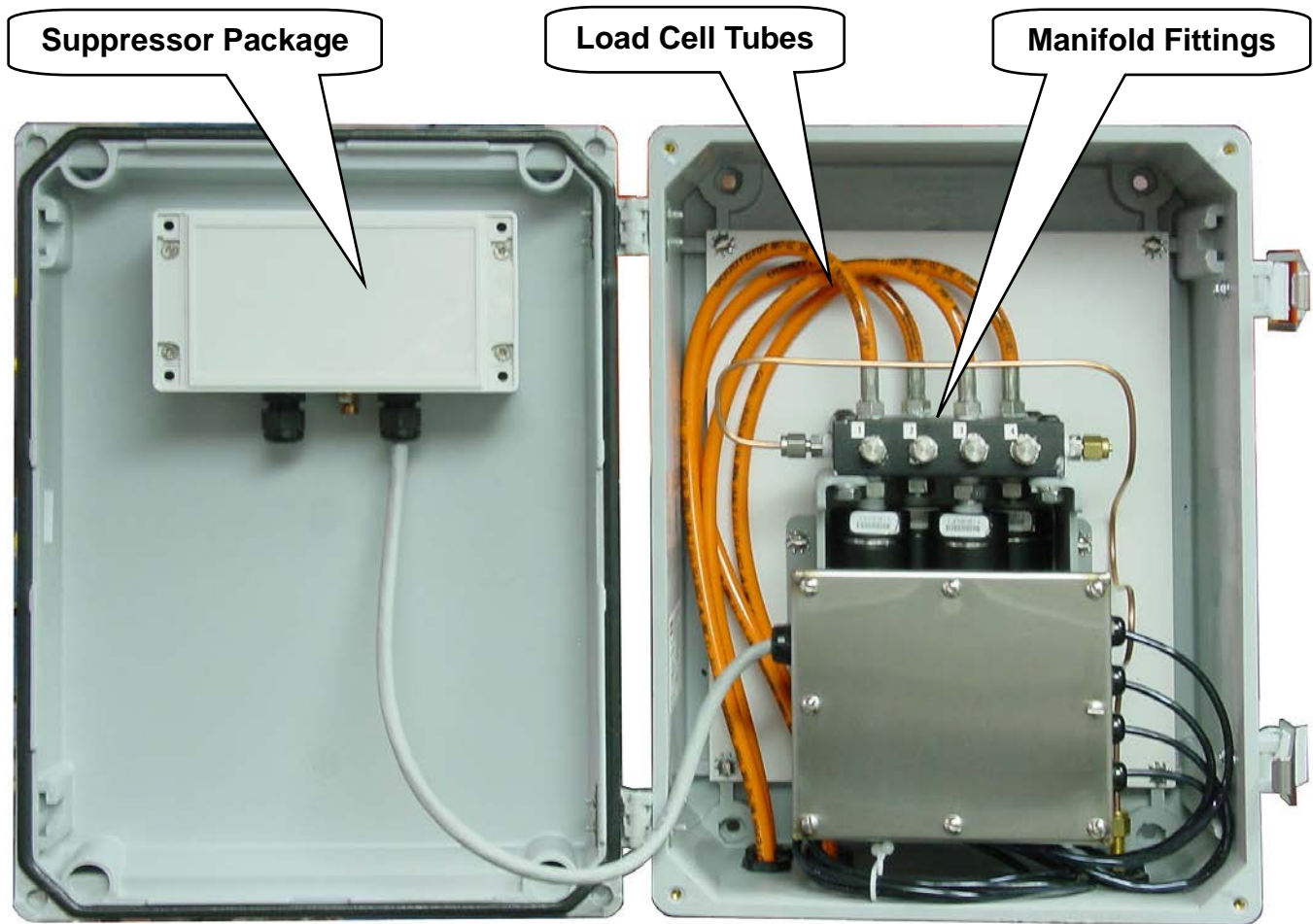

Figure No. 4
(3 & 4-Cell Totalizer Enclosure with Suppressor Package)

Connect the load cell tubes to the totalizer enclosure bulkhead fittings. The tubes are normally installed with the tube for cell #1 being installed toward the front of the enclosure with the odd cells on the left and even cells on the right. The tube caps should be installed finger tight then tightened an additional 1/8 to 1/4 of a turn to lock the fitting in place. All of the cell tubes should be installed at this time.

INSTALLATION, CONT.

Gauging SST Hydraulic Load Cells

Filling and bleeding the system is a very simple procedure. Begin by filling the pressure pump with oil and attaching it to the inlet port located on the outside, bottom right side of the totalizer enclosure. This pump is used to push oil through the system for bleeding purposes.

1. Next, remove the plastic gauge port plugs from load cell number one and place a .026 inch thick shim in each of the three gauge ports.
2. Place a container under the tube at the load cell to catch oil as air is purged from the line.



IMPORTANT! It should be noted that a load should **NEVER** be applied to a load cell unless the circuit for that cell is sealed and the cell has the correct amount of oil in it. Placing a load on a load cell with no oil, or the incorrect level of oil in it can damage the pressure diaphragm in the cell.

Figure No. 5
(Load Cell with 0.26 Shim in Gauge Port)

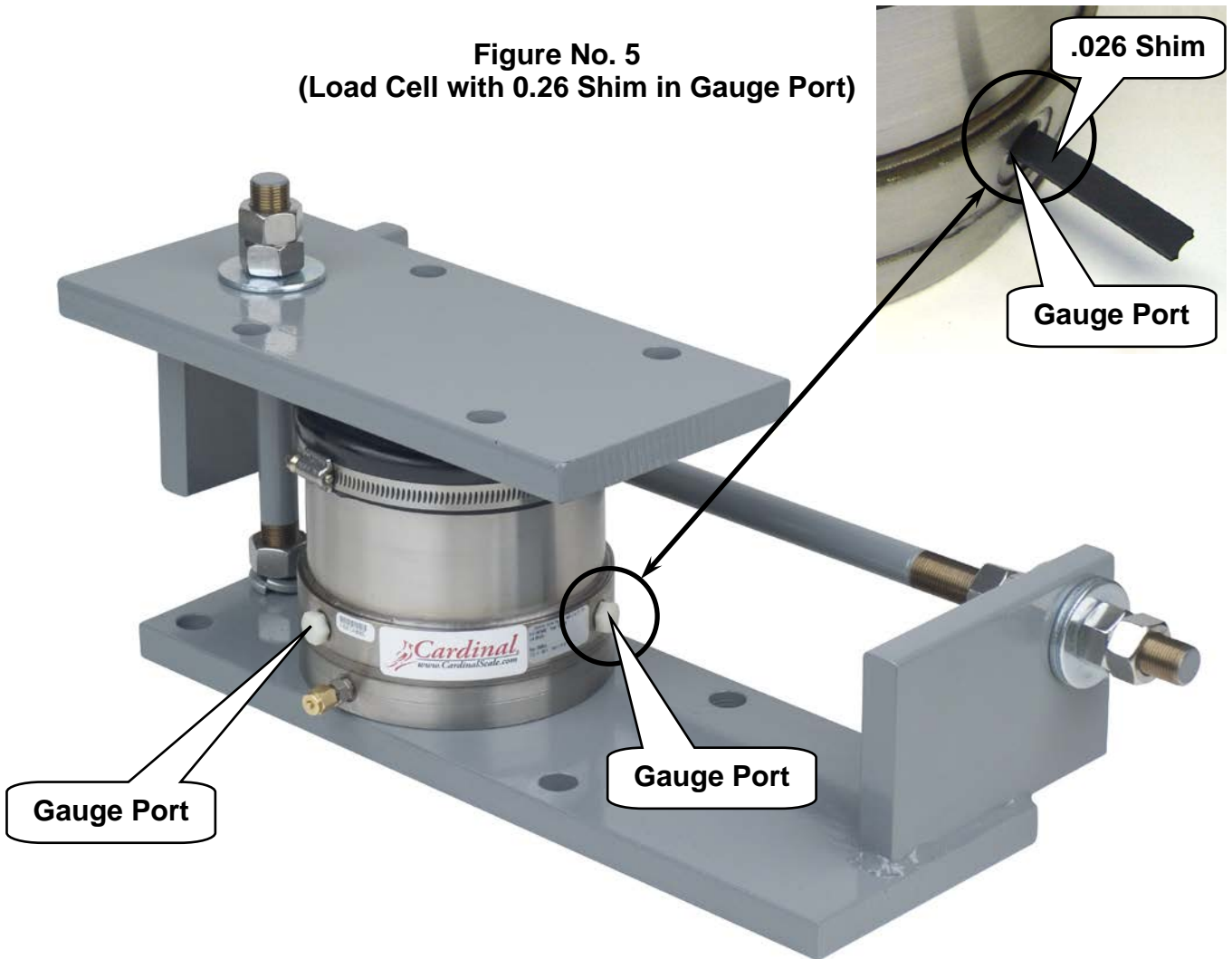

Figure No. 6 – Load Cell Gauge Ports

INSTALLATION, CONT.

Gauging SST Hydraulic Load Cells, Cont.

3. Open Manifold valve number one and pump oil through circuit number one until no air bubbles are seen coming out of the load cell end of the line.
4. Now remove the plug at the load cell inlet fitting and install the tube.
5. Tighten the tube nut finger tight, then an additional 1/8 to 1/4 turn.
6. Next remove the cap from the bleed port on the cell and attach a plastic bleed hose placing the end in a clean glass container.
7. Now pump 10 to 12 strokes of oil through the cell to ensure the cell has no trapped air inside it. If air bubbles are still visible coming from the plastic line continue pumping oil through the system until no further air remains.
8. Next, remove the plastic bleed tube and replace and snug the bleed port cap. After the cap is installed stroke the pump one more time and close the manifold valve for cell number one.
9. See if the three gauge shims are tight in the cell. If not open the bleed valve and pump another stroke of oil into the cell.
10. Continue this procedure until the shims in the cell are snug.
11. At this point tighten the bleed screw in the manifold.
12. Now carefully open the bleed cap and let a few drops of oil out of the load cell until the shims can be pulled free and tighten the bleed cap.
13. At this point the cell's gauge gap, at the tube connection "gauge port" (it is not necessary to gauge the other two ports) should be very close to the .027 +/- .001 gap that is necessary for operation.
14. Repeat this procedure on all cells in the system until all cells are bled and filled to the correct level.
15. Double check the gap after the weighbridge or vessel has been placed on the load cells.
16. Replace the gauge port caps on the cells.

INSTALLATION, CONT.

Gauging H2.5K and H5K Hydraulic Load Cells

The procedure for gauging the H2.5K and H5K load cells used in Guardian scales is significantly different than gauging the SST series of load cells. Where the SST series use a simple set of feeler gauges, the H2.5 and H5 load cells use a special gauging pin to gauge the correct amount of oil in the load cell.

The gauge pin is a simple tool that has corresponding diameters to match the gauge port dimensions on the specific load cell (the H2.5 and H5 are different).



Figure No. 7 – H2.5K Gauge

1. When we are setting up a scale using the H2.5 or H5 load cells we always want to start with the cell out of oil and the piston all the way down.
2. Carefully bleed the cell to make sure all air is out of the circuit, and then apply pressure on the top of the cell to force oil out of the bleed port.
3. Remove the bleed tube and install and tighten the port cap.
4. Next remove the gauge port plug and slide the gauge in the port. It will contact the piston before it goes all the way in.

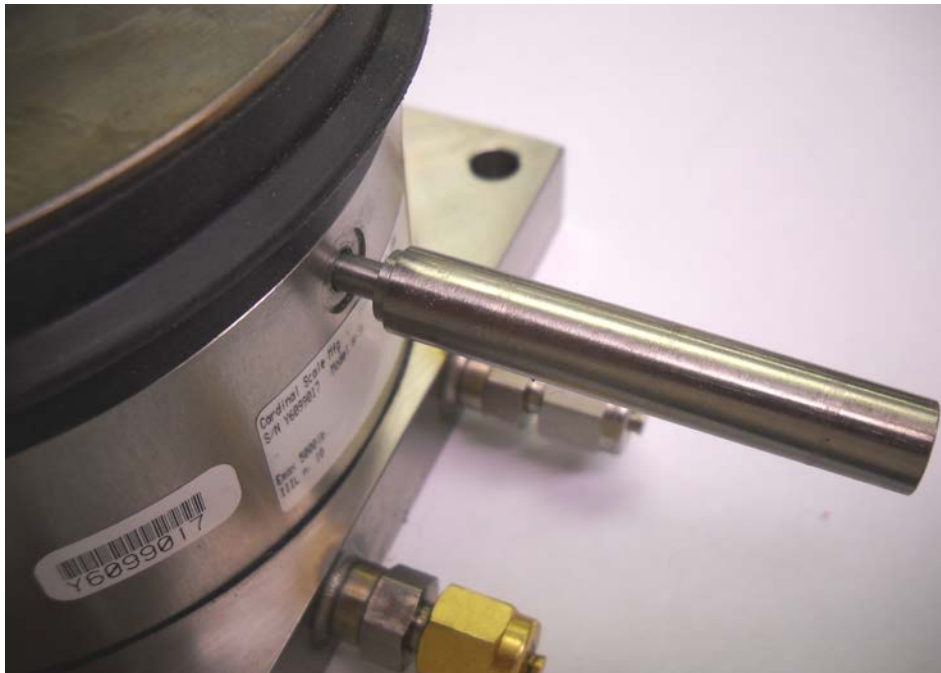

Figure No. 8 – Gauge Pin in Port with Piston Down

INSTALLATION, CONT.

5. Next open the corresponding valve on the manifold, push the gauge into the cell against the piston and apply a bit of pressure. Very slowly add oil to the cell until the gauge snaps into the gauge slot in the piston. This locates the piston at the correct height.



Figure No. 9
(Load Cell with correct amount of oil and Piston at correct height)

6. Tighten the manifold valve; make sure the gauge will slide in out of the gauge slot with Dead Load applied to the cell. Replace the gauge plug.



It is very important that you do not over fill the load cell. Small capacity Cardinal cells contain a diaphragm that can be damaged by over pressure. If the amount of oil in the cell is not known ALWAYS bleed all oil out of the cell to lower the piston and add fluid to bring it up to the correct height.

7. After all cells have been bled and filled, remove the pump from the totalizer and tighten all valves and system fittings.

FINAL ASSEMBLY



IMPORTANT INSTALLATION NOTES!



1. THE PURCHASERS OF FLOOR STAND TANK/HOPPER SCALE COMPONENTS ARE ADVISED TO INSTALL SAFETY STAY RODS. CARDINAL SCALE MANUFACTURING CO. (CSMC) WILL NOT BE RESPONSIBLE FOR THE STABILITY OF THE TANK.
2. IT IS RECOMMENDED THAT ALL PIPE CONNECTIONS TO THE TANK BE FLEXIBLE. (*CONSULT FACTORY FOR PIPING FLEXIBILITY.*)
3. PROVIDE FIRM, LEVEL STABLE AND SMOOTH SURFACE FOR LOAD CELL MOUNTING. LOAD CELLS MAY BE ROTATED TO SUIT CUSTOMER'S SPECIFIC INSTALLATION. SHIM AS REQUIRED.
4. FOR APPLICATIONS WHICH REQUIRE PERIODIC DEAD WEIGHT CALIBRATIONS, WEIGH LIFTING LUGS (*NOT PROVIDED BY CSMC*) ARE TO BE PROVIDED ON TANK.
5. CONSULT FACTORY FOR SPECIAL APPLICATIONS AND/OR INSTALLATIONS.
6. FOR SST10 INSTALLATIONS, REFERENCE DRAWING 1771-B280-GS, HYDRAULIC LOAD CELL STAND DIMENSIONAL OUTLINE DRAWING.

FOR SST25 INSTALLATIONS, REFERENCE DRAWING 1771-B282-GS, HYDRAULIC LOAD CELL STAND DIMENSIONAL OUTLINE DRAWING.

FOR SST50 INSTALLATIONS, REFERENCE DRAWING 1771-B230-0A, HYDRAULIC LOAD CELL STAND DIMENSIONAL OUTLINE DRAWING.

FOR SST75 INSTALLATIONS, REFERENCE DRAWING 1771-B229-0A, HYDRAULIC LOAD CELL STAND DIMENSIONAL OUTLINE DRAWING.

FOR SST100 INSTALLATIONS, REFERENCE DRAWING 1771-C320-0A, HYDRAULIC LOAD CELL STAND DIMENSIONAL OUTLINE DRAWING.
7. THE PURCHASER OF A FLOOR STAND TANK SCALE IS ADVISED TO INSTALL SAFETY PIERS OR OTHER DEVICES BENEATH THE WEIGHBRIDGE/SCALE, TO LIMIT MOVEMENT OF SCALE ASSEMBLY SHOULD ONE OR MORE SUPPORT MEMBERS FAIL.
8. CHECKS (*NOT FURNISHED BY CSMC*) ARE REQUIRED NEAR TOP OF TANKS SUBJECTED TO LATERAL (OVERTURNING) FORCES. CSMC WILL NOT BE RESPONSIBLE FOR THE STABILITY OF THE TANK.

FINAL ASSEMBLY, CONT.

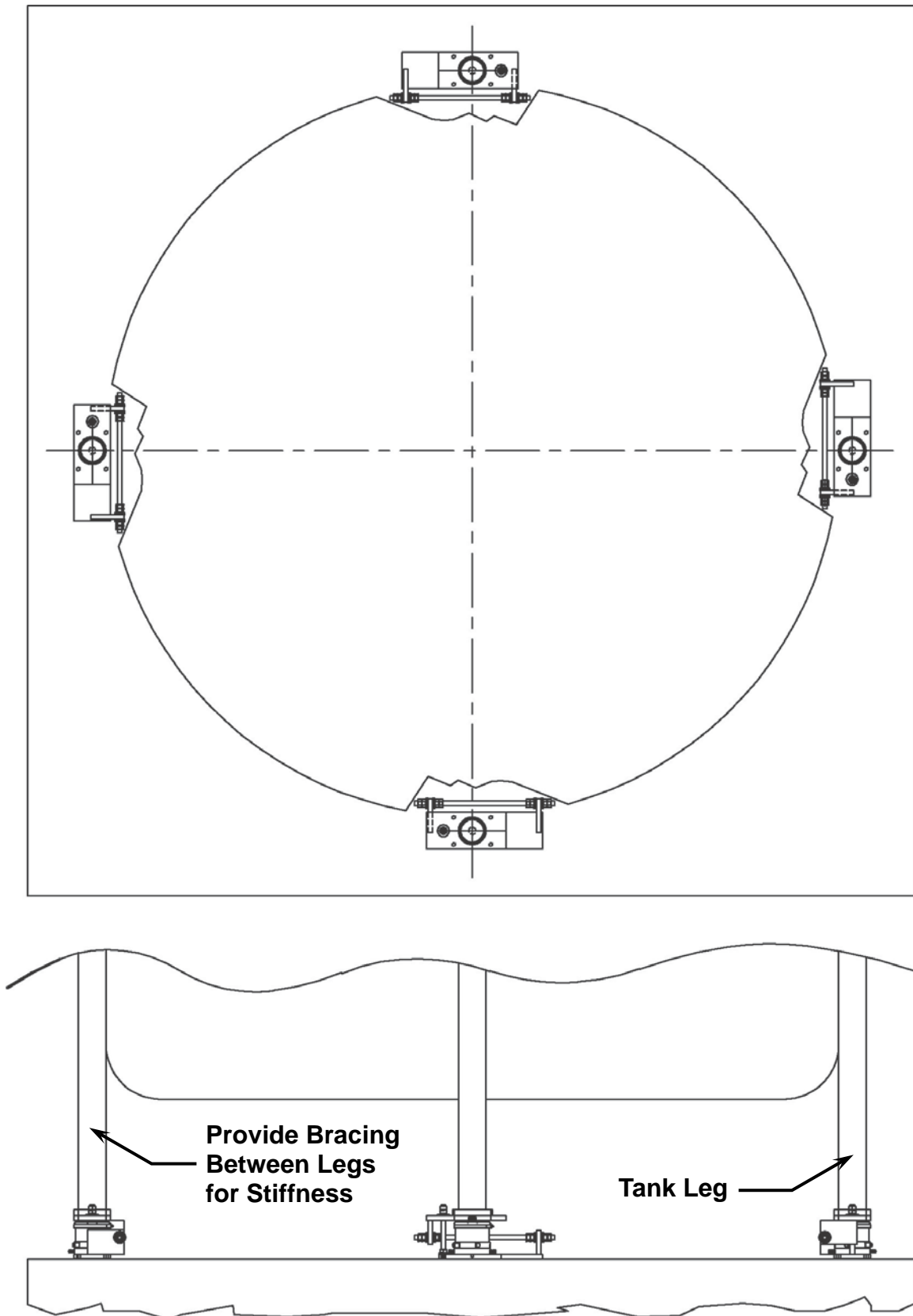

Figure No. 10 – Typical Mounting Configuration for 4-Mount Circular

INDICATOR INSTALLATION

1. Install the digital indicator.
2. The indicator cable is terminated at the Surge Suppression box located in the front door of the Totalizer enclosure. Make sure the surge suppression box is grounded back to the indicator and the AC power ground. Failure to provide a good ground will make the surge suppression inoperative. See Figure No. 11.

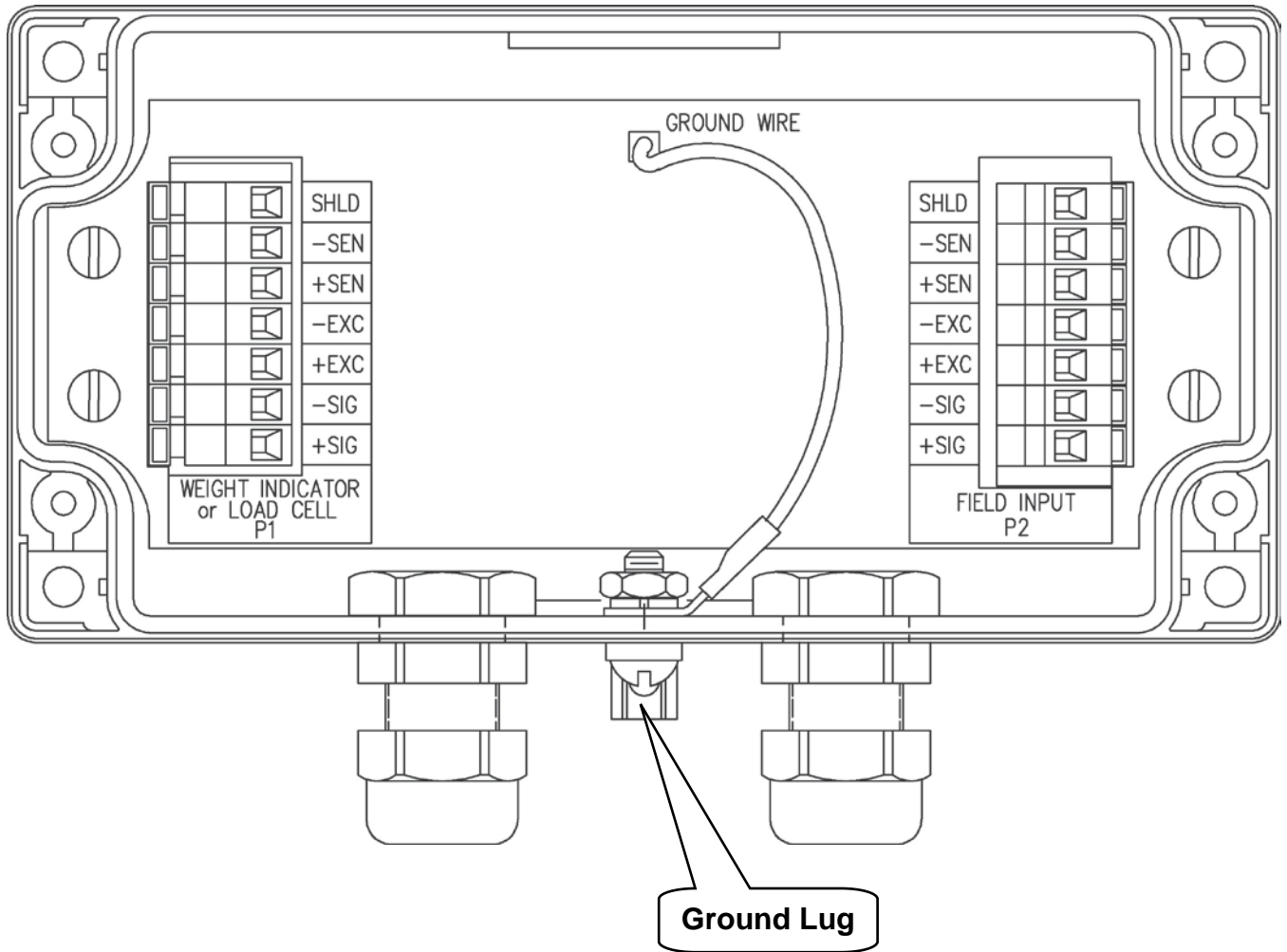

Figure No. 11 – Ground Lug Location



The Ground wire must be attached to the ground lug on the Suppressor Package. It should be run with the indicator cable and terminated to the ground lug on the weight indicator.

3. Power up the indicator, remove the signal lines from the summing card and read the signal from each transducer. Any transducer/cell pair that has a low output should be inspected to make sure it is taking load. If necessary place a small shim under the lower frame cell pad. **DO NOT ADD OIL TO THE CELL!!**

INDICATOR INSTALLATION, CONT.

- Span the indicator and corner seal the scale using the trim pots in the summing box like any other scale. Refer to Figure No. 12.

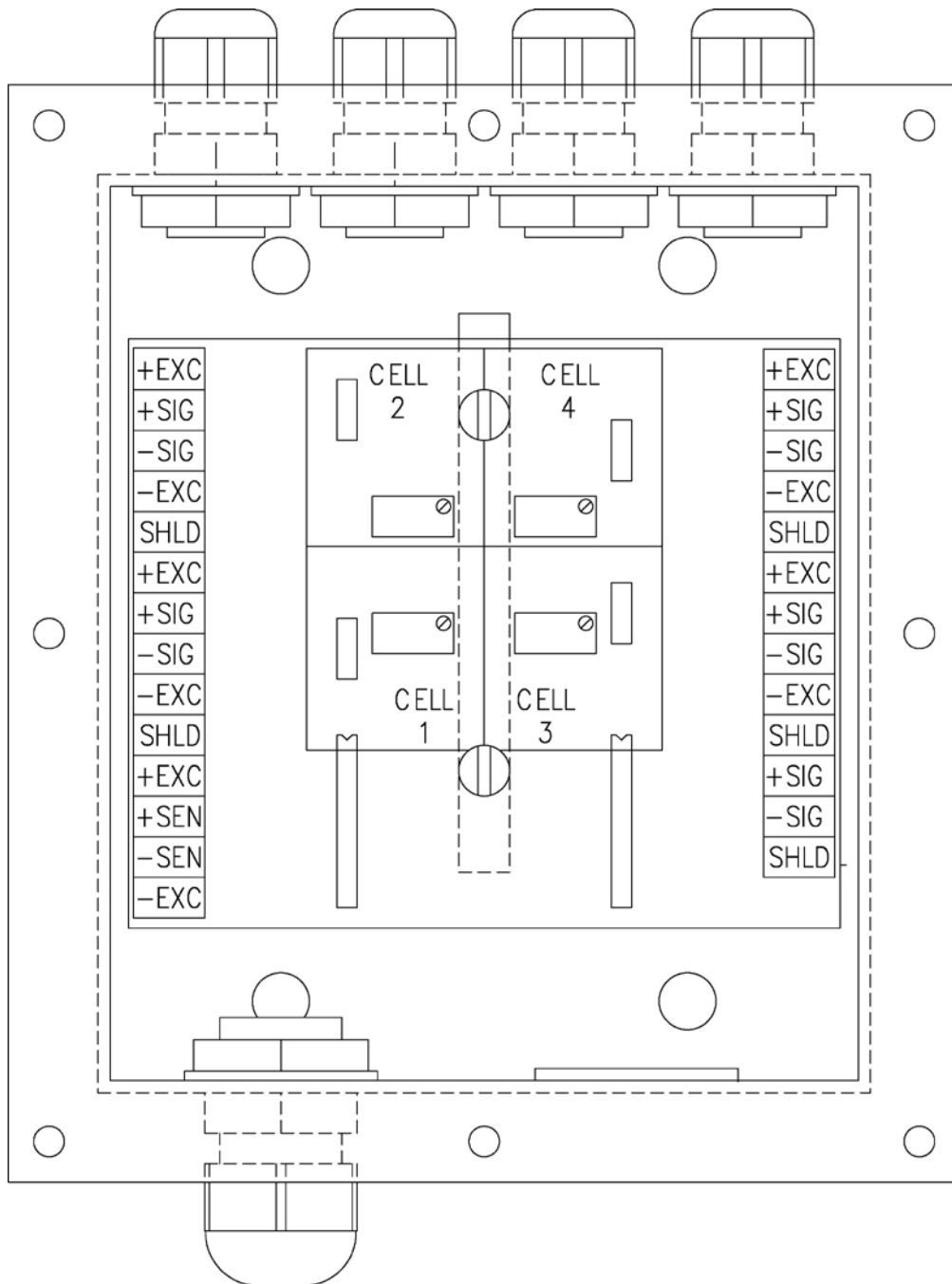

Figure No. 12 – J-Box Trim Assy.

- If necessary the Guardian Linearization software in the indicator can be used to tweak out any small errors.

CONFORMAL COATING

After installation and testing have been completed, the last step is to conformally coat the summing card using Cardinal Part number 6560-0017, CONFORMAL COATING, SILICONE.

Apply the coating by spraying from top to bottom, holding the can 6 to 8 inches from the summing card. It is best to apply 2 to 3 coats changing the angle a little each time for the best coverage.

The coating dries to the touch in 1 hour and cures in approximately 72 hours. The wiring should not be disturbed until after the curing time.

MAINTENANCE

Like any other scale the Guardian system needs routine maintenance to keep it working to its potential. Since there are no electronic components in the scale itself this is simplified on the Guardian.

1. After initial installation it is recommended that gauge gaps on the load cells be checked after the scale has been in use one week, again after one month of use and then every six months. If there is a very small leak in one of the cell circuits it may not be apparent during initial setup and calibration of the scale.
2. The scale should be inspected for dirt and debris under the weighbridge or vessel and cleaned every three (3) months or more often depending on the application.

TROUBLESHOOTING

SST Hydraulic Load Cells

If you are having a problem with a cell losing fluid (it will always be weighing light) remove the gauge port and see if the gauge will go into the cell. If not, we need to determine for sure that the cell has lost oil.

1. On the initial inspection, make sure the .028 feeler gauge will not enter the cell gauge gap. It is very important that if on inspection you find the gap at .035 inch that you find the source of the leak and eliminate it.
2. There is a rubber wear pad inside the cell that may compress slightly with use. A gap that has increased to .029 may just be because of the rubber pad compressing. Any increase in the gap above .029 means that fluid has left that circuit either at a cell, tube, or fitting, or inside the totalizer enclosure in a hose or manifold.
3. If the cell has lost fluid, you must find the source of the leak and fix it. Simply pumping more oil in the cell may get it going again but it will soon fail.
4. Clean all fittings and the area around the cell (spray brake or carb cleaner works well) then wrap the fittings with absorbent tissue and apply a heavy load to the cell that appears to be leaking.
5. After a period of time remove the tissue and inspect it for signs of oil. If no external leaks can be found the cell should be considered suspect.
6. If you are unsure of the level of oil in the cell ALWAYS open the bleed port and let oil out of the cell and add it back until the .028 feeler gauge will not enter the cell gauge gap.
7. After the problem has been found and fixed, remove all load from that cell and bleed and gap it to .027 inch. Then apply load and verify the gauge gap.

TROUBLESHOOTING, CONT.

H2.5K and H5K Hydraulic Load Cells

If you are having a problem with a cell losing fluid (it will always be weighing light) remove the gauge port and see if the gauge pin will go into the cell. If not, we need to determine for sure that the cell has lost oil.

1. Take a stiff piece of wire (.045 welding wire works well) and use it to feel the position of the slot in the load cell. If the cell is low or out of fluid you can feel the top edge of the slot with the wire, and above it the piston.



Figure No. 13 – Probing cell gauge port to determine piston position.

2. If the cell has lost fluid, you must find the source of the leak and fix it. Simply pumping more oil in the cell may get it going again but it will soon fail.
3. Clean all fittings and the area around the cell (spray brake or carb cleaner works well) then wrap the fittings with absorbent tissue and apply a heavy load to the cell that appears to be leaking.
4. After a period of time remove the tissue and inspect it for signs of oil. If no external leaks can be found the cell should be considered suspect.
5. If you are unsure of the level of oil in the cell ALWAYS open the bleed port and let oil out of the cell and add it back until the gauge snaps in the groove in the piston.

TROUBLESHOOTING, CONT.

PTG-3K Transducer

The Cardinal PTG-3K pressure transducer is a simple device to convert hydraulic pressure into a voltage output that can be easily summed and trimmed. It can be checked much the same as a standard strain gauge based load cell.



Figure No. 14 – PTG-3K Pressure Transducer

The PTG-3K is rated at 1mV/V. Because of this you will see exactly half of the output from the transducer that you would normally see out of a 2mV/V load cell. The Transducer uses a modified Wheatstone bridge circuit and uses Balco resistors for span temperature compensation as well as copper alloy for zero temperature compensation.

To troubleshoot the PTG-3K you will first measure the resistance between the red and white signal leads. This value should be from 340 ohms to 360 ohms. Resistance between the black and green excitation leads will be from 402 ohms to 422 ohms.

Resistance from the circuit wires to the transducer body should be 5K Megohms (5 billion ohms) Normally a standard VOM meter is not capable of measuring this resistance. A Megohmmeter (also called an Insulation Resistance Tester) is required.

Since the PTG-3K will always have some amount of pressure on the gauged surfaces, it is impossible to check the absolute zero balance condition of the transducer without removing the transducer from the hydraulic circuit. This is something you normally will not want to do. When the scale is first set up you should record the output of the transducer with the deck jacked up off of the load cell. This value should be recorded and left inside the transducer cabinet so at a later date you can compare the no-load output from the transducer to see if there has been a significant shift in zero. A change of .2mV from the initial reading may indicate a change in the sensor output.

If a sensor must be changed in the scale, first jack up the weighbridge at the corresponding load cell to eliminate pressure from that circuit. Apply 2 wraps of Teflon tape to the new transducer threads and force them all the way into the bottom of the threads. Remove the transducer to be replaced, clean the manifold threads and check for loose Teflon in the manifold and install the new PTG-3K. The sensor should be very tight in the manifold to avoid leaks. Bleed the circuit and set the gauge gap in the cell and the scale should be ready to be calibrated.

RECOMMENDED SEALING PROCEDURE

If your Guardian Hydraulic Scale System is used in a commercial application and your local metrology laws require the use of physical sealing, a lead and wire security seal can be installed to prevent access to the interior components of the Totalizer Enclosure.

To prevent access to the interior components, refer to the illustrations below and seal the enclosure as follows:

1. Install the sealing tab before the "O" ring.
2. Tighten the screw.
3. Bend the tab as shown.
4. Install sealing wire.
5. Pull the wire tight and install the lead seal.
6. The screw can not be removed without damaging the seal.

Note that the sealing tab and screw are available from the Cardinal Scale Mfg. Parts Department.

PARTS LIST

8530-B159-08 SEALING TAB
6021-1708 SCW FILLISTER. MACHINE-SCW 10-32X.75

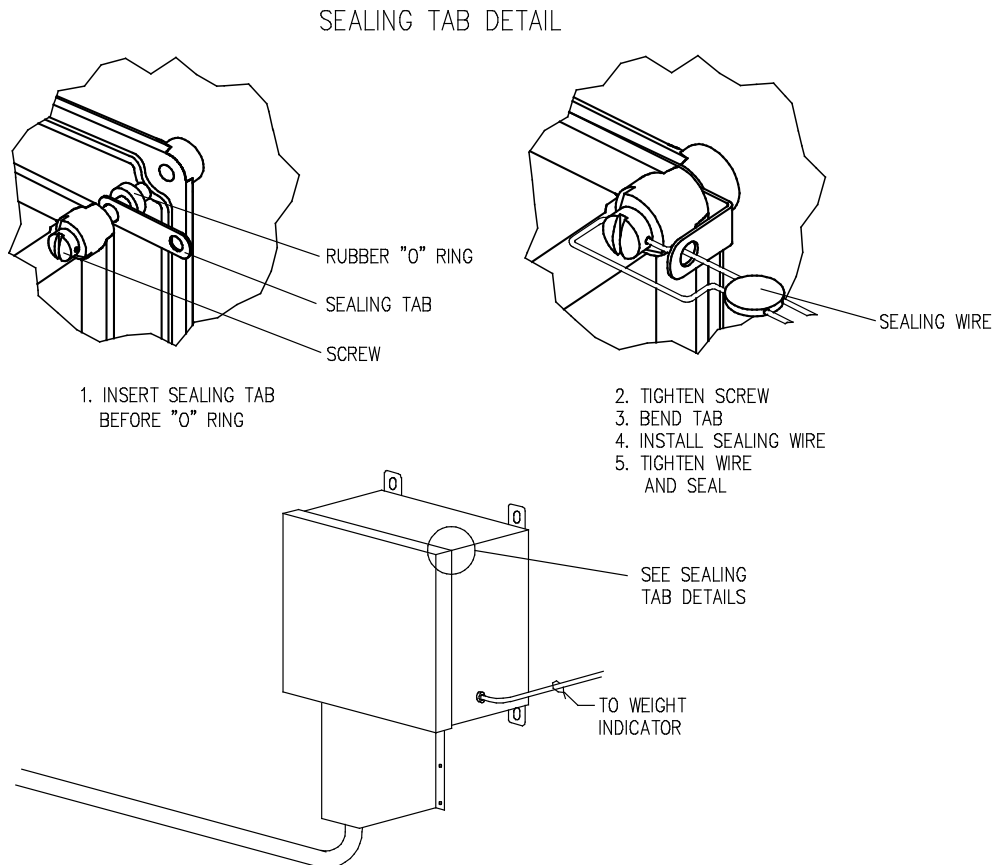

PARTS IDENTIFICATION

H2.5K Load Cell Assembly

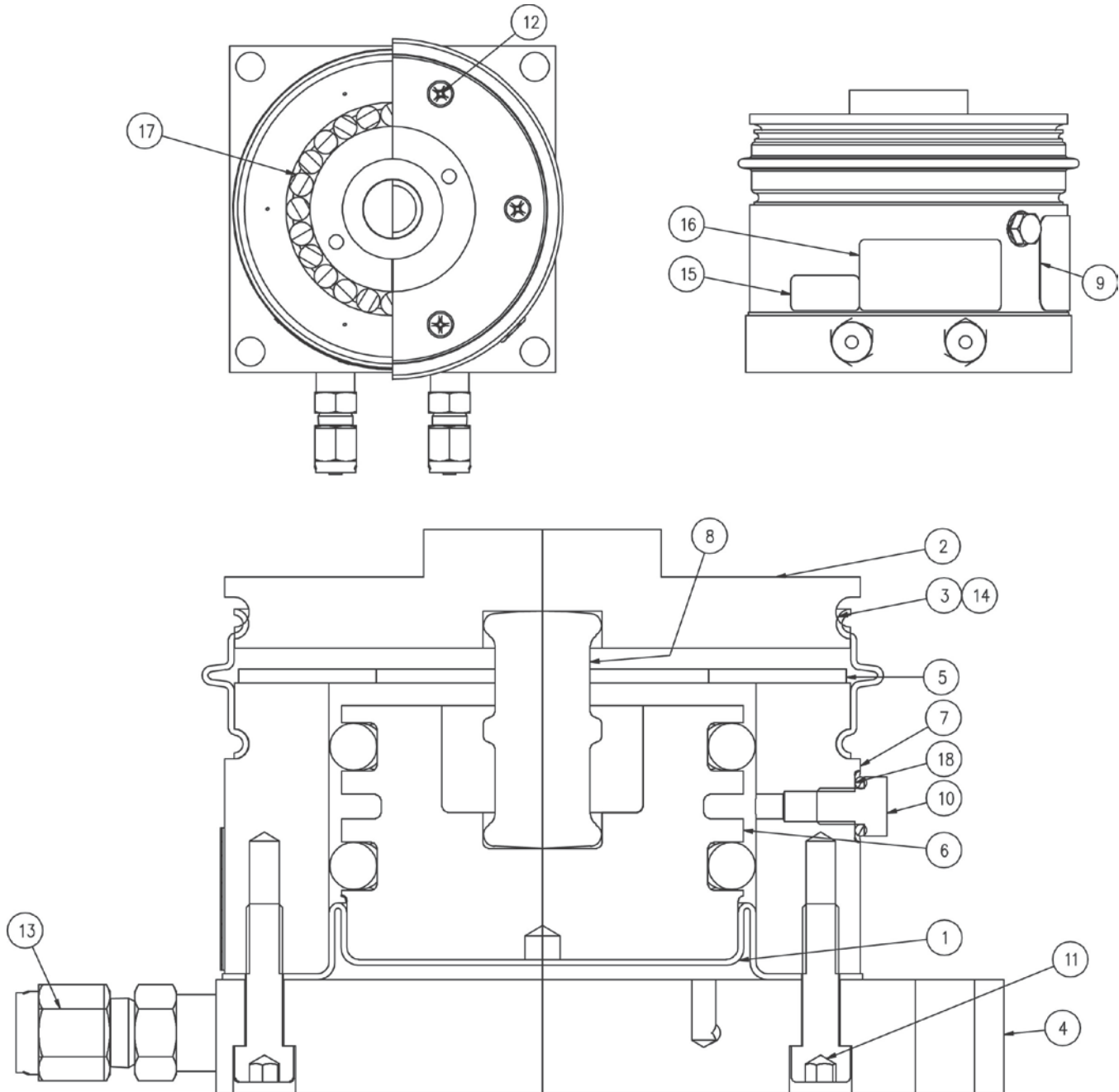

PARTS IDENTIFICATION, CONT.

H2.5K Load Cell Assembly

ITEM NO.	QTY.	PART NUMBER	DESCRIPTION
1	1	1771-B200-08	DIAPHRAGM
2	1	1771-B201-08	HEAD
3	1	1771-B234-08	BOOT
4	1	1771-B235-0A	BASE WELDMENT
5	1	1771-B237-08	RETAINER
6	1	1771-C202-08	PISTON
7	1	1771-C203-08	CYLINDER
8	1	1932-B015-08	ROCKER
9	1	5930-B106-08	LABEL: CARDINAL LOGO W/WEB ADDRESS
10	1	6021-0452	SCW HEX HEAD MACHINE SCW 10-32x.25
11	8	6021-0567	SCW UN-BRAKO SOCKET-HD. CAP-SCREW.. 10-32X.750
12	6	6021-1130	SCW FLAT HEAD MACHINE SCW 06-32x.250
13	2	6031-0521	FITTING, STAINLESS 1/8" PLUG
14	.05	6560-1120	ADHESIVE LOCTITE 380 INSTANT ADHSVE 1 OZ
15	1	6600-0650	LABEL HI-TEMP INVENTORY TRACKING .37x.9"
16	1	6600-0653	SER. TAG 3/4 x 1 1/2 SILVER MYLAR
17	48	6650-1031	BALL BEARING, 0.250 DIA GRADE 25
18	1	6650-1056	O-RING .187ID x .312OD x .062 THICK

PARTS IDENTIFICATION, CONT.
H2.5K Load Cell Stand
(HBC2.5, Mild Steel and HBCS2.5, Stainless Steel)

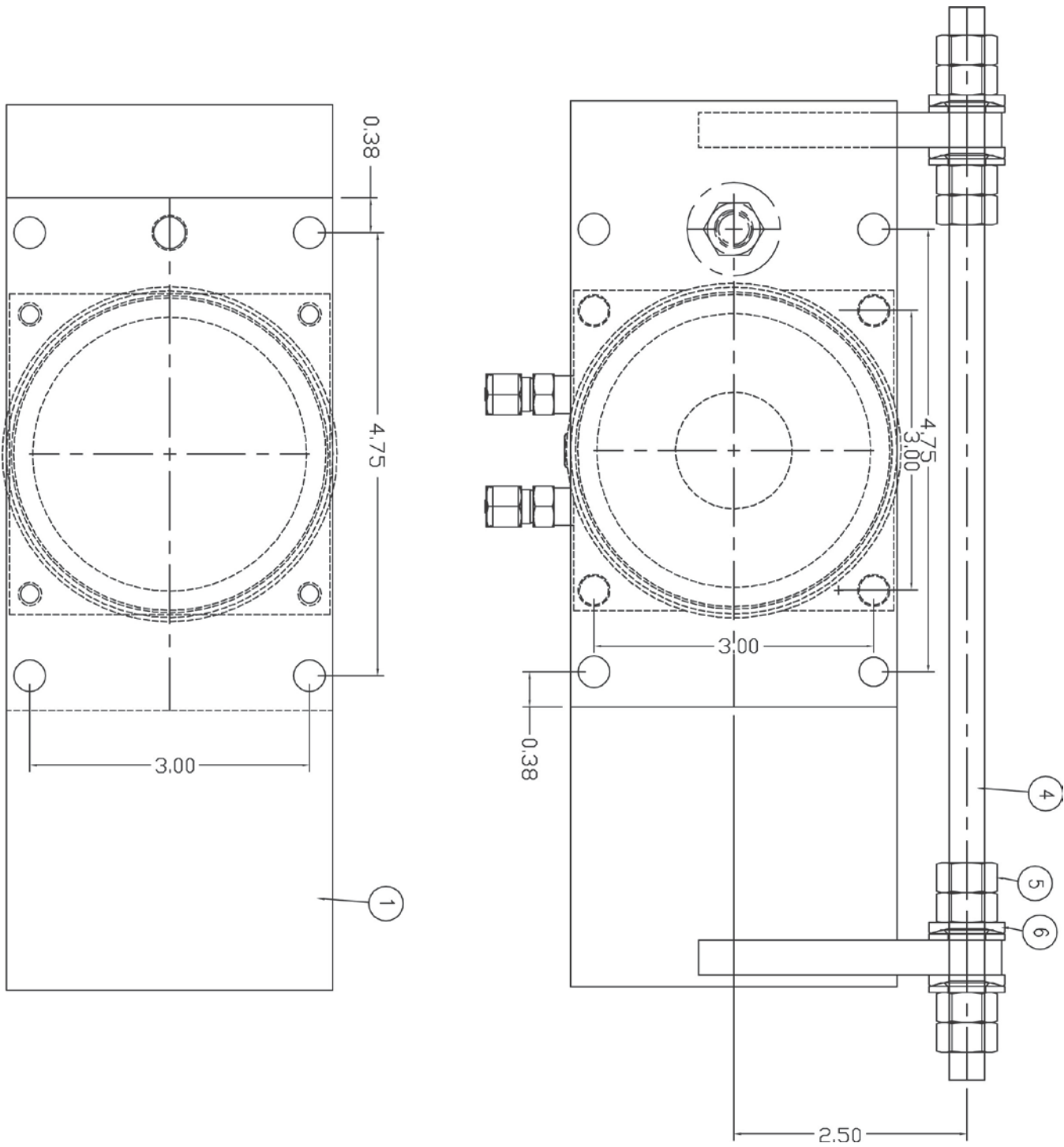

PARTS IDENTIFICATION, CONT.

H2.5K Load Cell Stand (HBC2.5, Mild Steel and HBCS2.5, Stainless Steel)

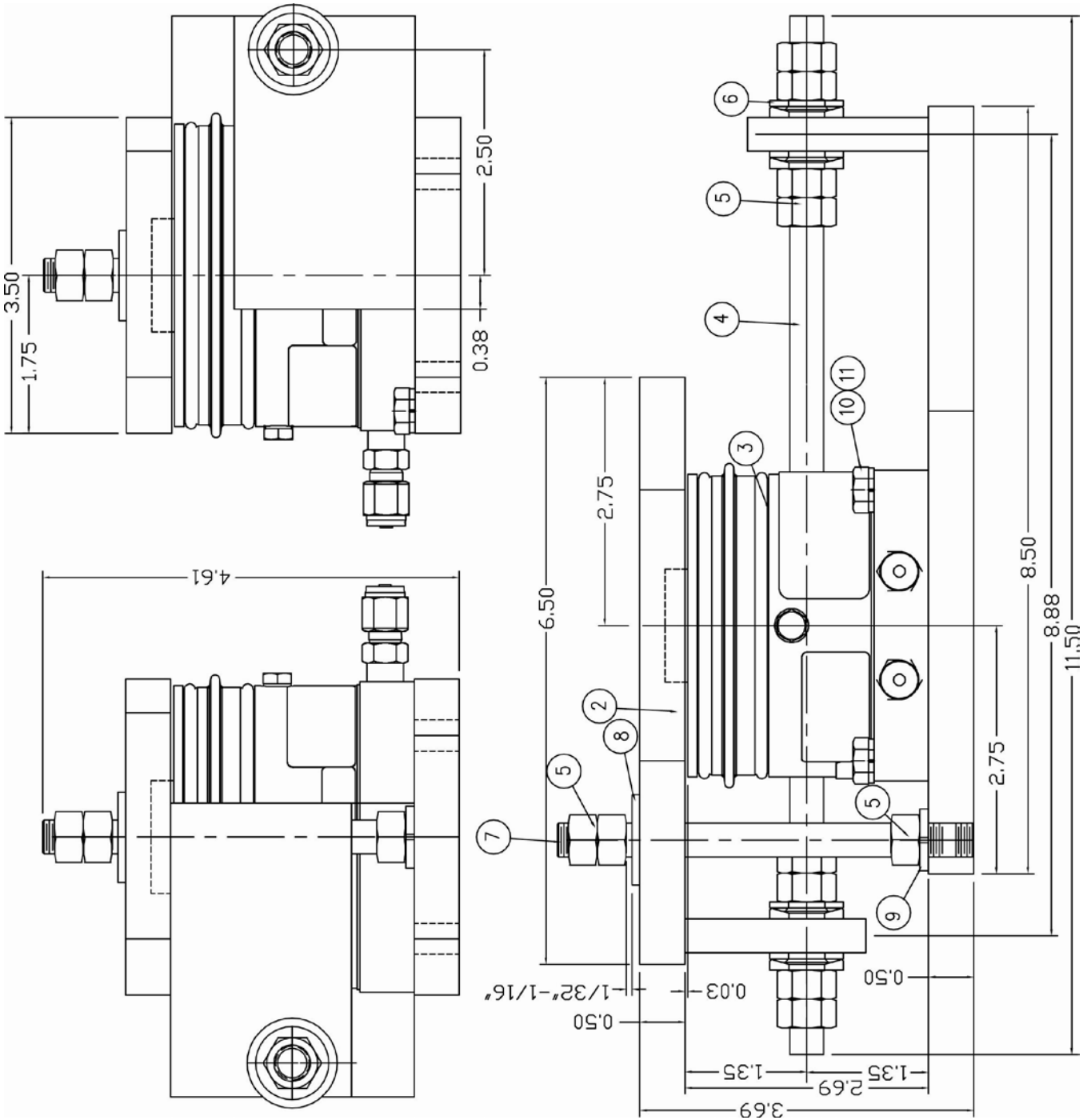

PARTS IDENTIFICATION, CONT.
H2.5K Load Cell Stand (HBC2.5, Mild Steel)

ITEM NO.	QTY.	PART NUMBER	DESCRIPTION
1	1	1771-B284-0A	BASE PLATE
2	1	1771-B286-0A	TOP PLATE
3	1	H2.5K	LOAD CELL
4	1	1771-B288-08	CHECK ROD HORIZ. 3/8-24UNF X 11 1/2" W/3 1/2" THD BOTH ENDS
5	11	6013-0400	NUT HEX 3/8-24 UNF Z/P
6	4	6024-0130	WASHER SPHERICAL .406
7	1	1771-B287-08	CHECK BOLT VERT. 3/8-24 UNF X 4 5/8" FULL THD BOTH ENDS
8	1	1771-B289-08	WASHER FLAT 3/8"
9	1	6024-0054	WASHER LOCK 3/8" Z/P
10	4	6024-0039	WASHER LOCK 1/4"
11	4	6007-0006	BLT HEX HEAD 1/4-20UNC X 1"

PARTS IDENTIFICATION, CONT.
H2.5K Load Cell Stand (HBCS2.5, Stainless Steel)

ITEM NO.	QTY.	PART NUMBER	DESCRIPTION
1	1	1771-B284-1A	BASE PLATE
2	1	1771-B286-1A	TOP PLATE
3	1	H2.5K	LOAD CELL
4	1	1771-B288-18	CHECK ROD HORIZ. 3/8-24UNF X 11 1/2" W/3 1/2" THD BOTH ENDS
5	11	6013-0001	NUT HEX 3/8-24 UNF S.S.
6	4	6024-0131	WASHER SPHERICAL .406 S.S.
7	1	1771-B287-18	CHECK BOLT VERT. 3/8-24 UNF X 4 5/8" FULL THD BOTH ENDS S.S.
8	1	1771-B289-18	WASHER FLAT 3/8" S.S.
9	1	6024-0046	WASHER LOCK 3/8" S.S.
10	4	6024-0040	WASHER LOCK 1/4" S.S.
11	4	6007-0012	BLT HEX HEAD 1/4-20UNC X 1" S.S.

PARTS IDENTIFICATION, CONT.

H5K Load Cell Assembly

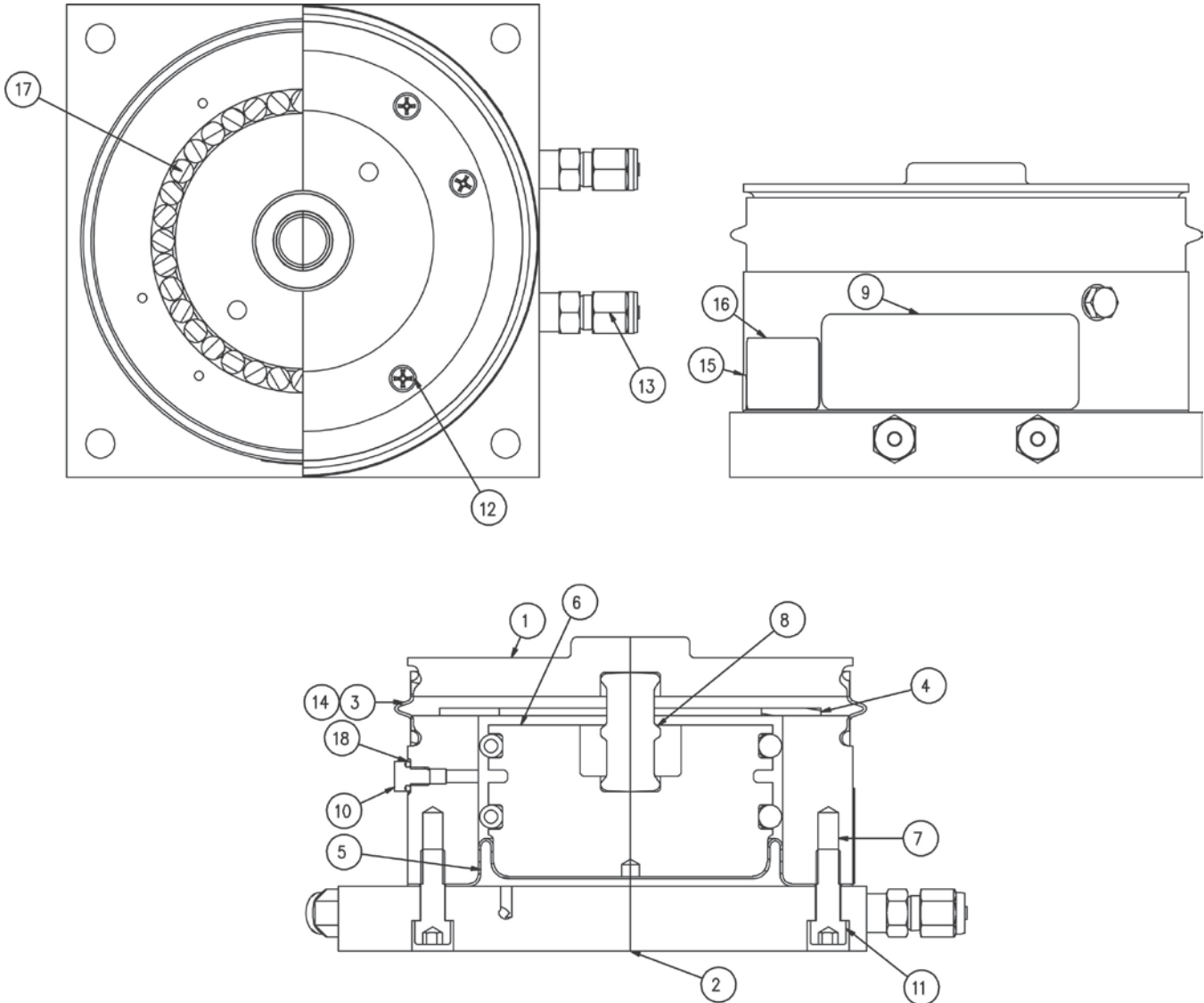

PARTS IDENTIFICATION, CONT.

H5K Load Cell Assembly

ITEM NO.	QTY.	PART NUMBER	DESCRIPTION
1	1	1771-B251-08	HEAD
2	1	1771-B255-0A	BASE WELDMENT
3	1	1771-B257-08	BOOT, H5K
4	4	1771-B350-08	RETAINER
5	1	1771-B250-08	DIAPHRAGM-H5K
6	1	1771-C252-08	PISTON
7	1	1771-C253-08	CYLINDER
8	1	1932-B015-08	ROCKER
9	1	5930-B106-08	LABEL: CARDINAL LOGO W/WEB ADDRESS
10	1	6021-0452	SCW HEX HEAD MACHINE SCW 10-32x.25
11	10	6021-1111	SCW UN-BRAKO SOCKET-HD. CAP-SCREW.. .25-28x.750
12	6	6021-1130	SCW FLAT HEAD MACHINE SCW 06-32x.250
13	2	6031-0521	FITTING, STAINLESS 1/8" PLUG
14	.05	6560-1120	ADHESIVE LOCTITE 380 INSTANT ADHSVE 1 OZ
15	1	6600-0650	LABEL HI-TEMP INVENTORY TRACKING .37x.9"
16	1	6600-0653	SER. TAG 3/4 x 1 1/2 SILVER MYLAR
17	72	6650-1031	BALL BEARING, 0.250 DIA GRADE 25
18	1	6650-1056	O-RING .187ID x .312OD x .062 THICK

PARTS IDENTIFICATION, CONT.
H5K Load Cell Stand
(HBC5, Mild Steel and HBCS5, Stainless Steel)

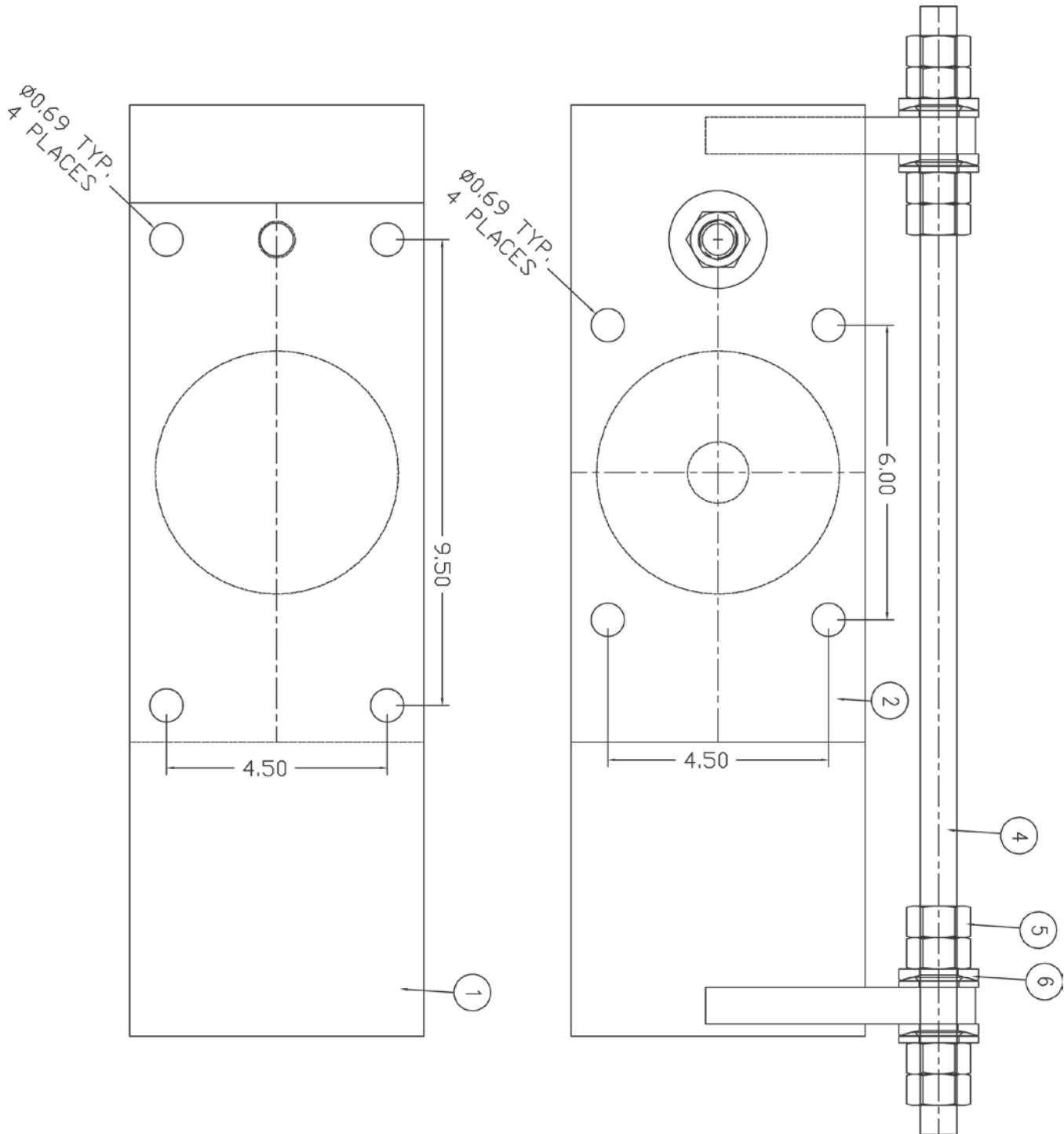

PARTS IDENTIFICATION, CONT.

H5K Load Cell Stand (HBC5, Mild Steel and HBCS5, Stainless Steel)

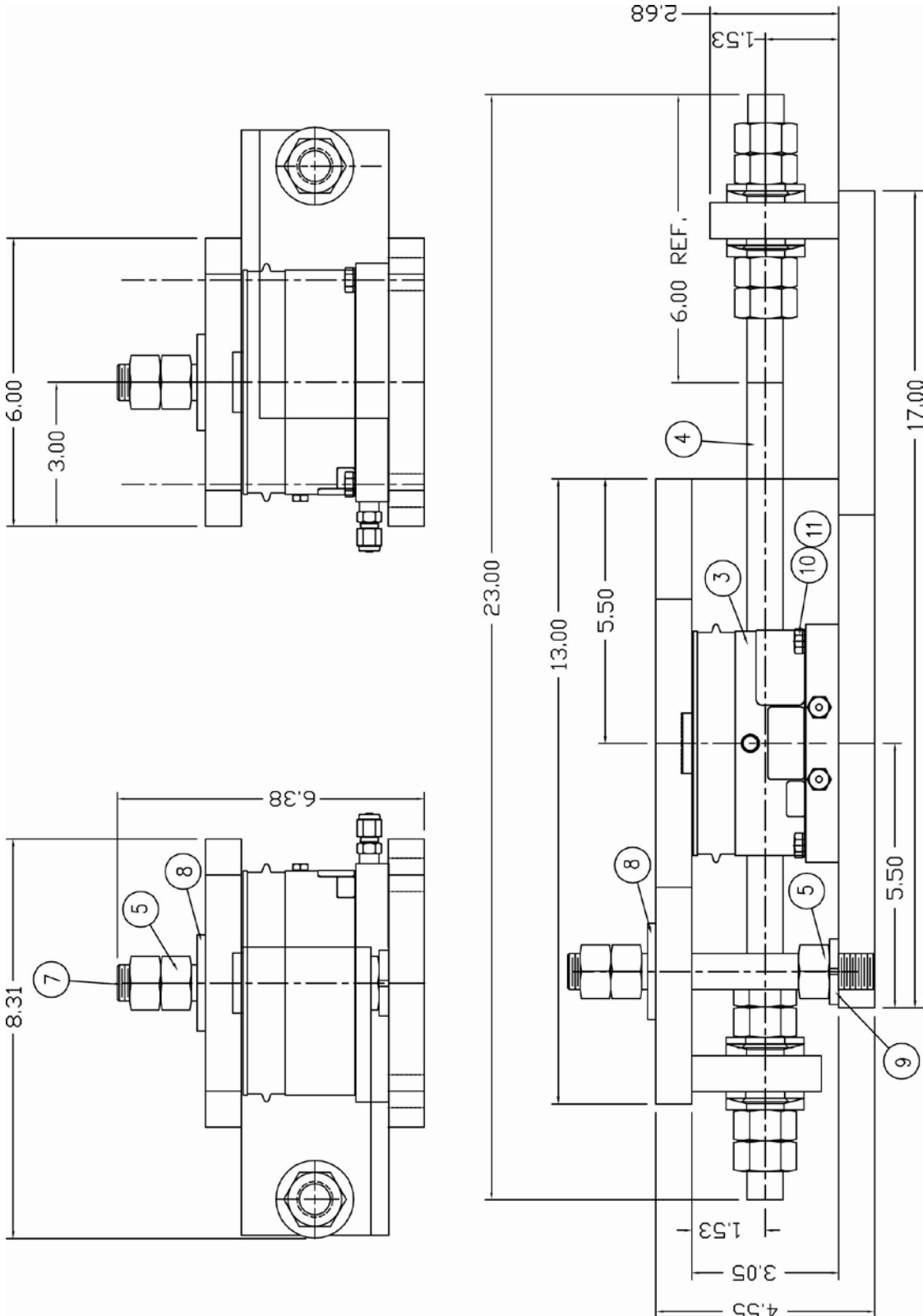

PARTS IDENTIFICATION, CONT.
H5K Load Cell Stand (HBC5, Mild Steel)

ITEM NO.	QTY.	PART NUMBER	DESCRIPTION
1	1	1771-B293-0A	BASE PLATE
2	1	1771-B294-0A	TOP PLATE
3	1	H5K	LOAD CELL
4	1	1771-B271-18	CHECK ROD HORIZ. 3/4-16UNF X 23" W/6" THD BOTH ENDS
5	11	6013-0188	NUT HEX 3/4-16 UNF Z/P
6	4	3501-B107-0A	WASHER SPHERICAL .781
7	1	1771-B292-18	CHECK BOLT VERT. 3/4-16 UNF X 7" W/2" THD BOTH ENDS
8	1	6024-0018	WASHER FLAT 3/4" Z/P
9	1	6024-0054	WASHER LOCK 3/4" Z/P
10	4	6024-0039	WASHER LOCK 1/4"
11	4	6007-0006	BLT HEX HEAD 1/4-20UNC X 1"

PARTS IDENTIFICATION, CONT.
H5K Load Cell Stand (HBCS5, Stainless Steel)

ITEM NO.	QTY.	PART NUMBER	DESCRIPTION
1	1	1771-B293-1A	BASE PLATE S.S.
2	1	1771-B294-1A	TOP PLATE S.S.
3	1	H5K	LOAD CELL
4	1	1771-B271-08	CHECK ROD HORIZ. 3/4-16UNF X 23" W/6" THD BOTH ENDS S.S.
5	11	6013-0186	NUT HEX 3/4-16 UNF S.S.
6	4	3501-B272-0A	WASHER SPHERICAL .781 S.S.
7	1	1771-B292-18	CHECK BOLT VERT. 3/4-16 UNF X 7" W/2" THD BOTH ENDS S.S.
8	1	6024-1499	WASHER FLAT 3/4" S.S.
9	1	6024-1489	WASHER LOCK 3/4" S.S.
10	4	6024-0040	WASHER LOCK 1/4" S.S.
11	4	6007-0012	BLT HEX HEAD 1/4-20UNC X 1" S.S.

PARTS IDENTIFICATION, CONT.

SST10 Load Cell Assembly

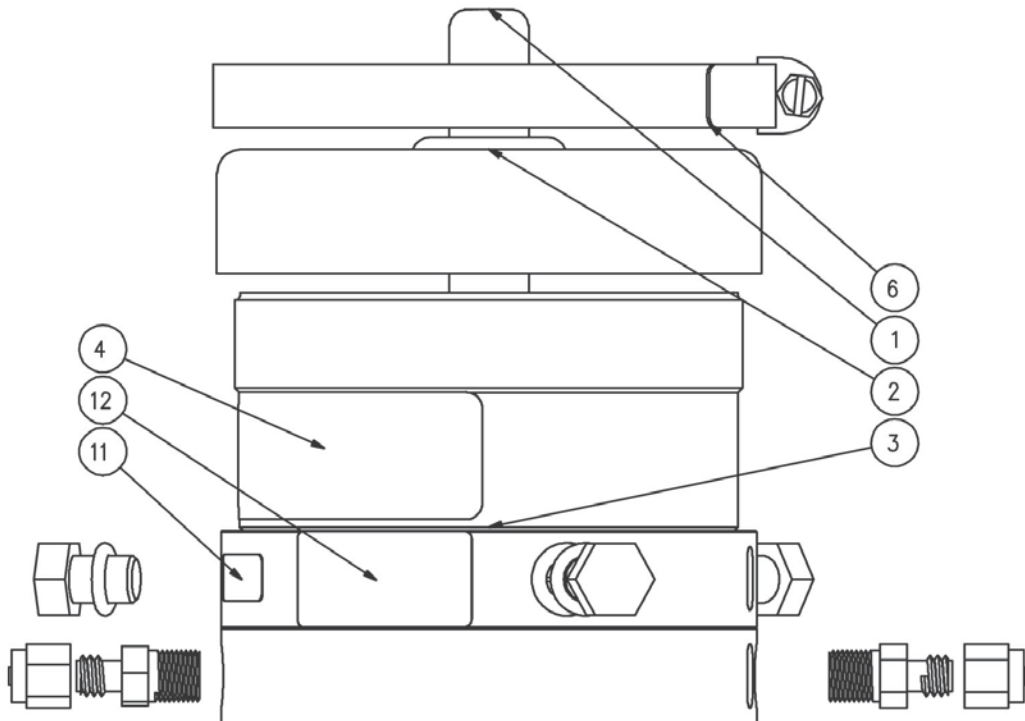
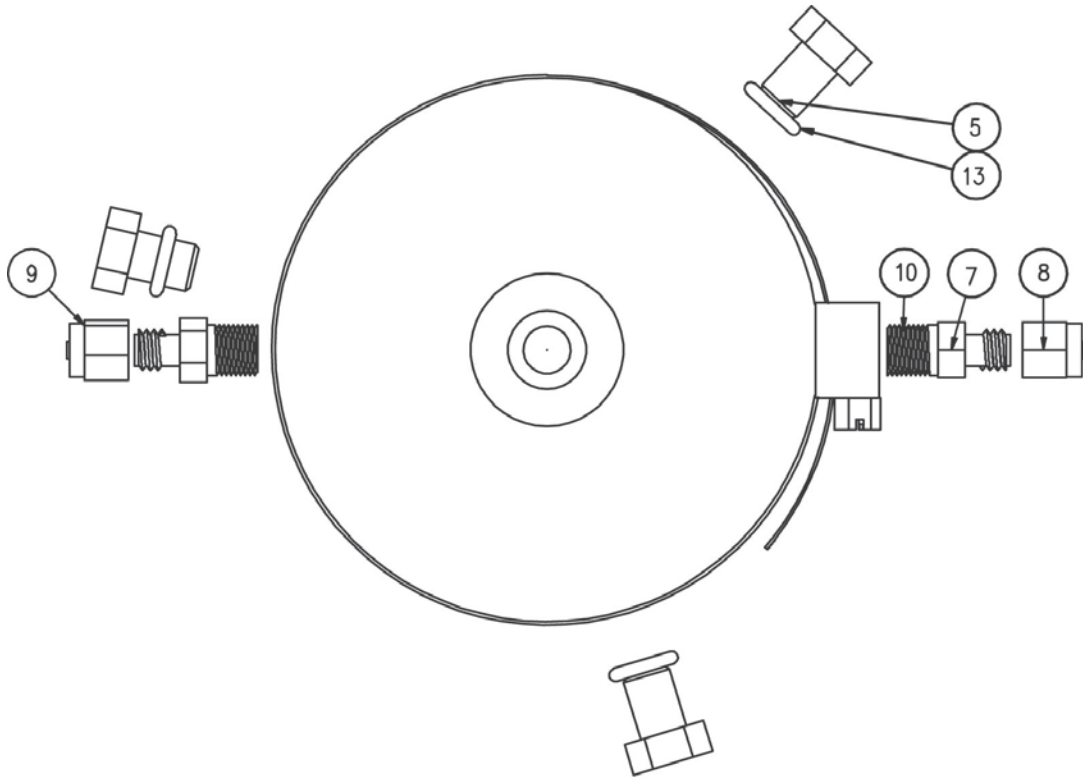

PARTS IDENTIFICATION, CONT.

SST10 Load Cell Assembly

ITEM NO.	QTY.	PART NUMBER	DESCRIPTION
1	1	1771-C140-08	LOAD POST
2	1	1771-C143-08	RUBBER BOOT, SST10
3	1	1771-D142-0A	LOAD CELL WELDMENT FOR SST10
4	1	5930-B106-08	LABEL: CARDINAL LOGO W/WEB ADDRESS
5	3	6007-0175	BLT HEX HD 3/8-16 X 1/2" NYLON
6	1	6028-0104	HOSE CLAMP, 3 5.8 – 6 1/2
7	2	6031-0500	CONNECTOR, MALE 1/8" OD – 1/8" MNPT S.S.
8	2	6031-0502	PLUG FITTING 1/8" BRASS
9	1	6031-0521	FITTING, STAINLESS 1/8" PLUG
10	.01	6560-1127	ADHESIVE LOCTITE 545 THREAD SEALANT
11	1	6600-0650	LABEL HI-TEMP INVENTORY TRACKING .37 X .9"
12	1	6600-0653	SER. TAG 3/4 X 1 1/2 SILVER MYLAR
13	3	6650-1088	O-RING .364 ID X .572 OD X .104 THK

PARTS IDENTIFICATION, CONT.
SST10 Load Cell Stand
(HBC10, Mild Steel and HBCS10, Stainless Steel)

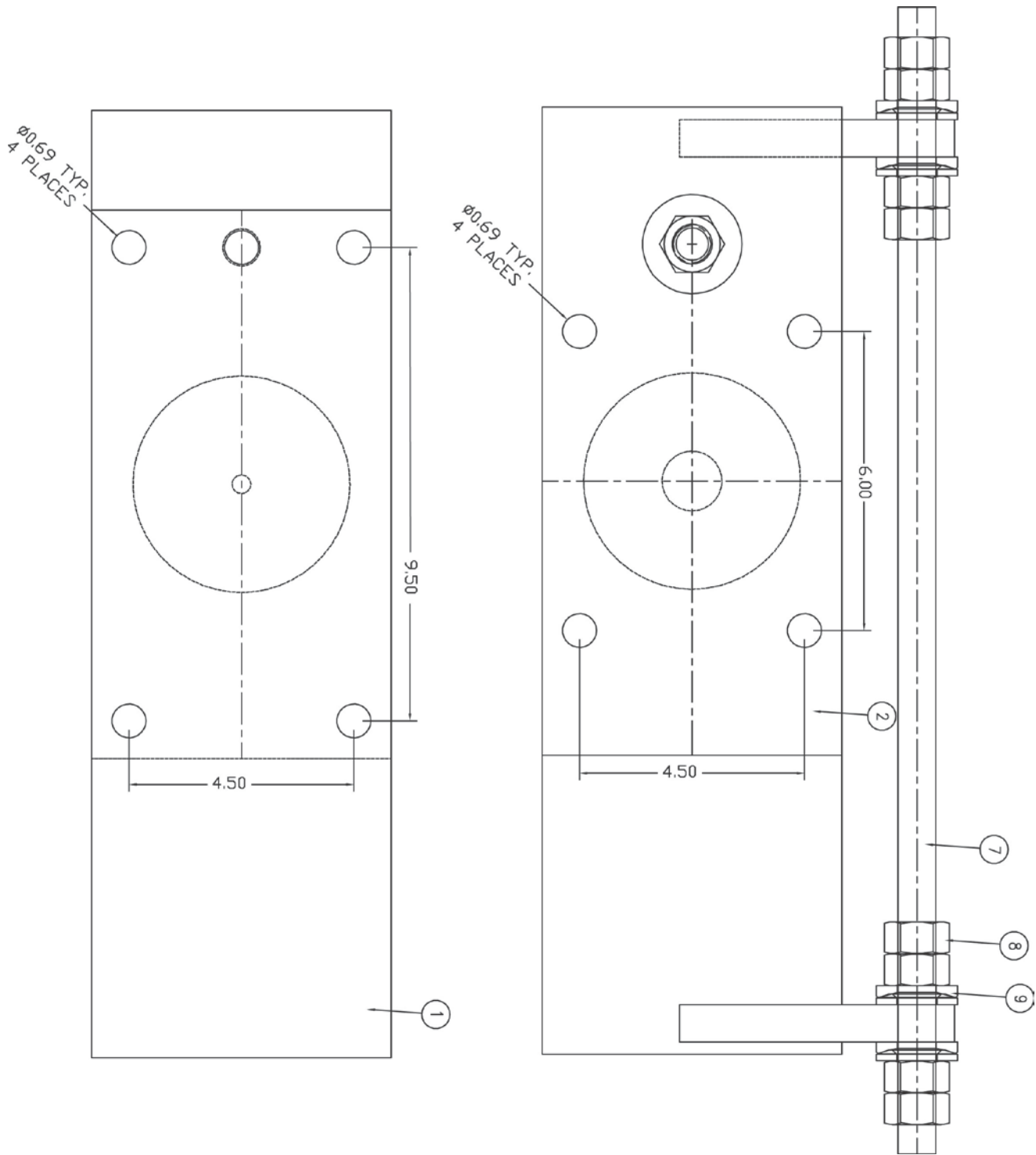

PARTS IDENTIFICATION, CONT.

SST10 Load Cell Stand (HBC10, Mild Steel and HBCS10, Stainless Steel)

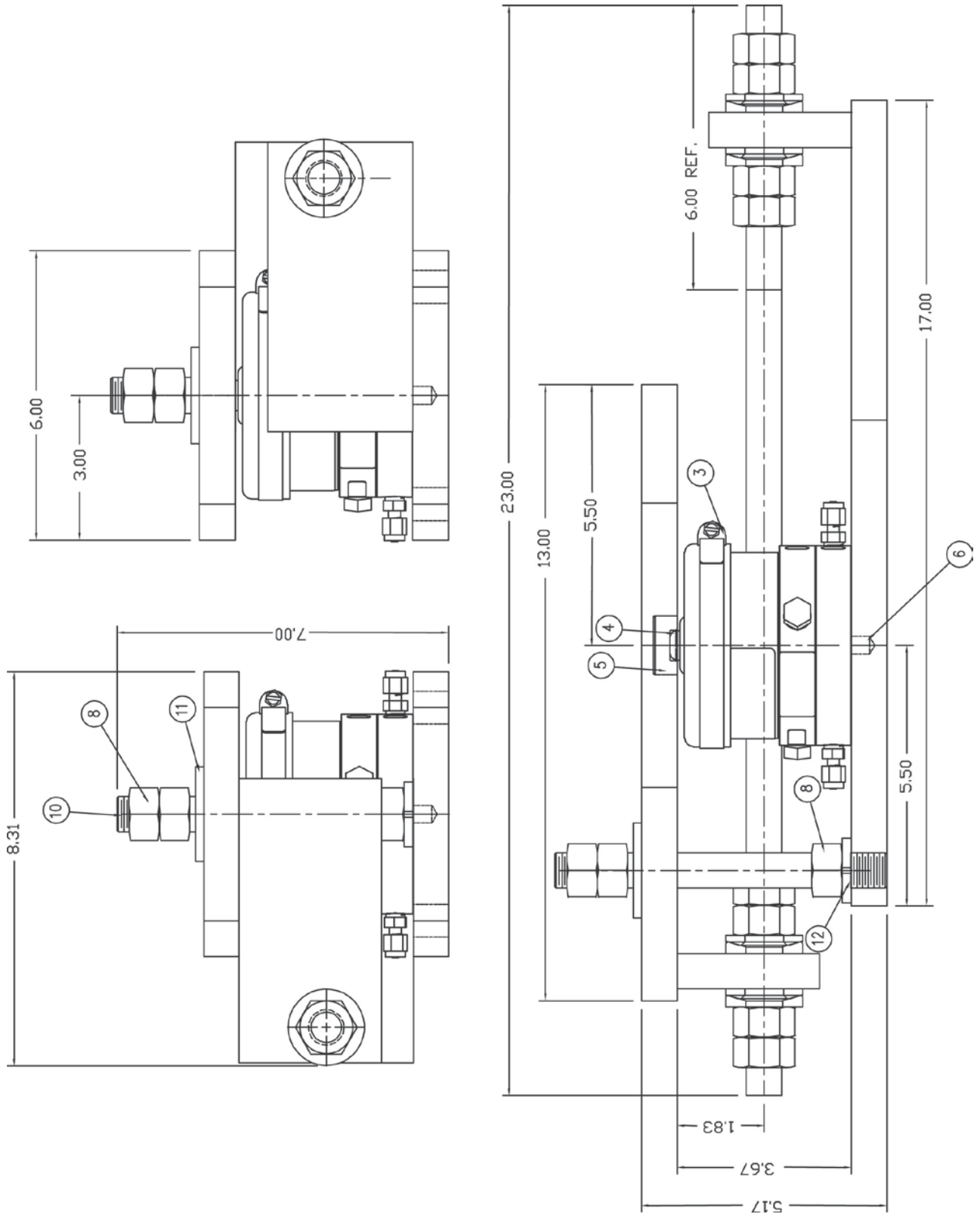

PARTS IDENTIFICATION, CONT.
SST10 Load Cell Stand (HBC10, Mild Steel)

ITEM NO.	QTY.	PART NUMBER	DESCRIPTION
1	1	1771-B269-1A	BASE PLATE
2	1	1771-B270-1A	TOP PLATE
3	1	SST10	LOAD CELL
4	1	1771-C140-08	LOAD PIN, 5/8" DIA X 4.06 LONG
5	1	1771-B214-08	LOAD BUTTON, 1 1/4 DIA
6	1	6020-0517	DOWEL PIN, 3/8 DIA X 3/4 LONG
7	1	1771-B271-18	CHECK ROD HORIZ. 3/4-16UNF X 23" W/6" THD BOTH ENDS
8	11	6013-0188	NUT HEX 3/4-16 UNF Z/P
9	4	3501-B107-0A	WASHER SPHERICAL .781
10	1	1771-B273-18	CHECK BOLT VERT. 3/4-16 UNF X 7" W/2" THD BOTH ENDS
11	1	6024-0018	WASHER FLAT 3/4" Z/P
12	1	6024-0054	WASHER LOCK 3/4" Z/P

PARTS IDENTIFICATION, CONT.
SST10 Load Cell Stand (HBCS10, Stainless Steel)

ITEM NO.	QTY.	PART NUMBER	DESCRIPTION
1	1	1771-B269-0A	BASE PLATE
2	1	1771-B270-0A	TOP PLATE
3	1	SST10	LOAD CELL
4	1	1771-C140-08	LOAD PIN, 5/8" DIA X 4.06 LONG
5	1	1771-B214-08	LOAD BUTTON, 1 1/4 DIA 17-4 S.S.
6	1	6020-0517	DOWEL PIN, 3/8 DIA X 3/4 LONG (S.S.)
7	1	1771-B271-08	CHECK ROD HORIZ. 3/4-16UNF X 23" W/6" THD BOTH ENDS (S.S.)
8	11	6013-0188	NUT HEX 3/4-16 UNF (S.S.)
9	4	1771-B272-0A	WASHER SPHERICAL .781
10	1	1771-B273-08	CHECK BOLT VERT. 3/4-16 UNF X 7" W/2" THD BOTH ENDS (S.S.)
11	1	6024-1499	WASHER FLAT 3/4" S.S.
12	1	6024-1489	WASHER LOCK 3/4" S.S.

PARTS IDENTIFICATION, CONT.

SST25 Load Cell Assembly

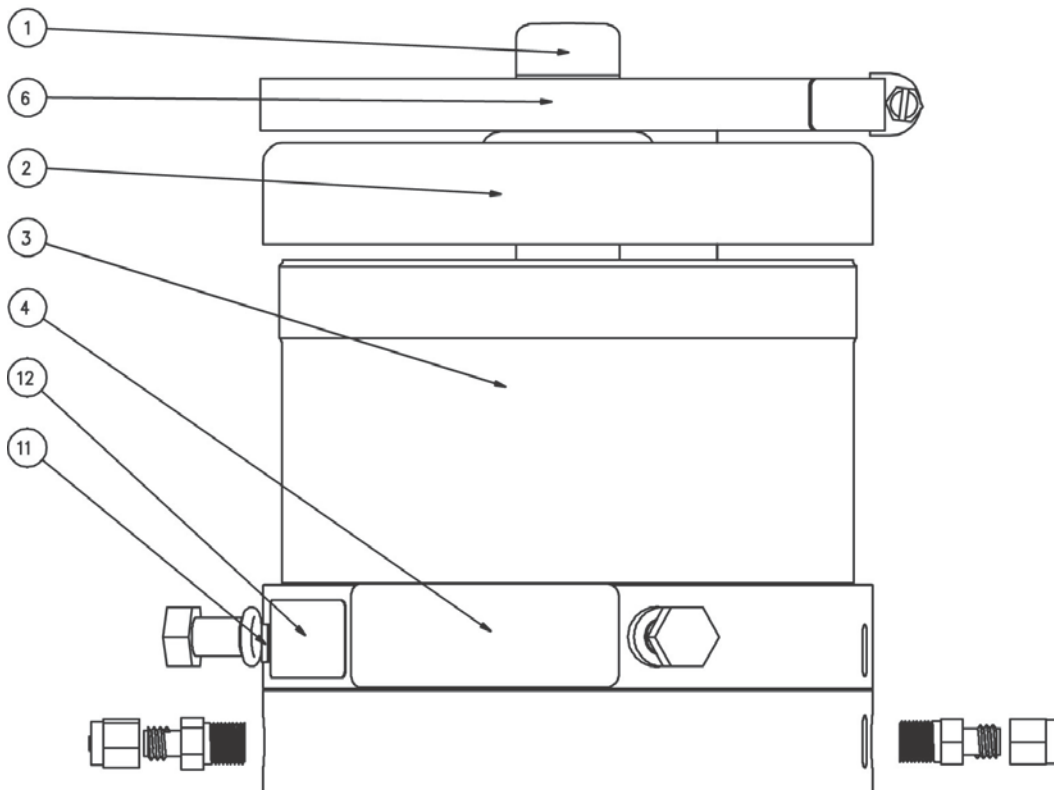
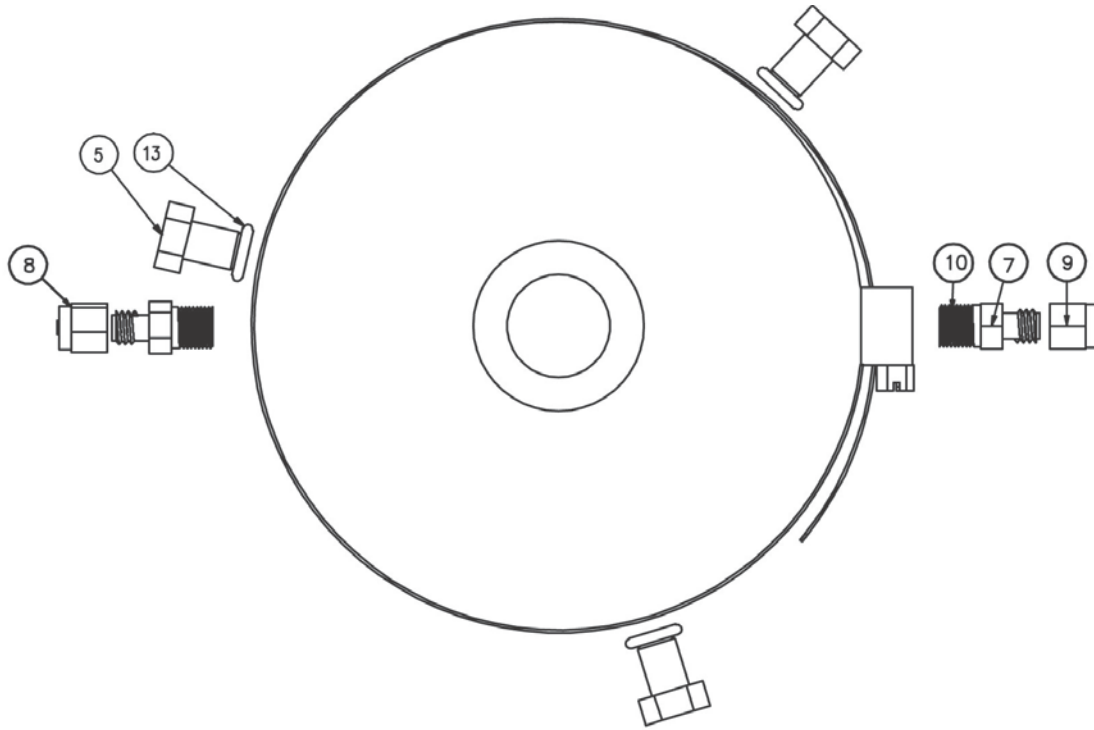

PARTS IDENTIFICATION, CONT.

SST25 Load Cell Assembly

ITEM NO.	QTY.	PART NUMBER	DESCRIPTION
1	1	1771-C161-08	LOAD POST
2	1	1771-C163-08	RUBBER BOOT, SST25
3	1	1771-D162-0A	LOAD CELL WELDMENT FOR SST25
4	1	5930-B106-08	LABEL: CARDINAL LOGO W/WEB ADDRESS
5	3	6007-0175	BLT HEX HD 3/8-16 X 1/2" NYLON
6	1	6028-0104	HOSE CLAMP, 3 5.8 – 6 1/2
7	2	6031-0500	CONNECTOR, MALE 1/8" OD – 1/8" MNPT S.S.
8	2	6031-0502	PLUG FITTING
9	1	6031-0521	FITTING, STAINLESS 1/8" PLUG
10	.01	6560-1127	ADHESIVE LOCTITE 545 THREAD SEALANT
11	1	6600-0650	LABEL HI-TEMP INVENTORY TRACKING .37 X .9"
12	1	6600-0653	SER. TAG 3/4 X 1 1/2 SILVER MYLAR
13	3	6650-1088	O-RING .364 ID X .572 OD X .104 THK

PARTS IDENTIFICATION, CONT.
SST25 Load Cell Stand
(HBC25, Mild Steel and HBCS25, Stainless Steel)

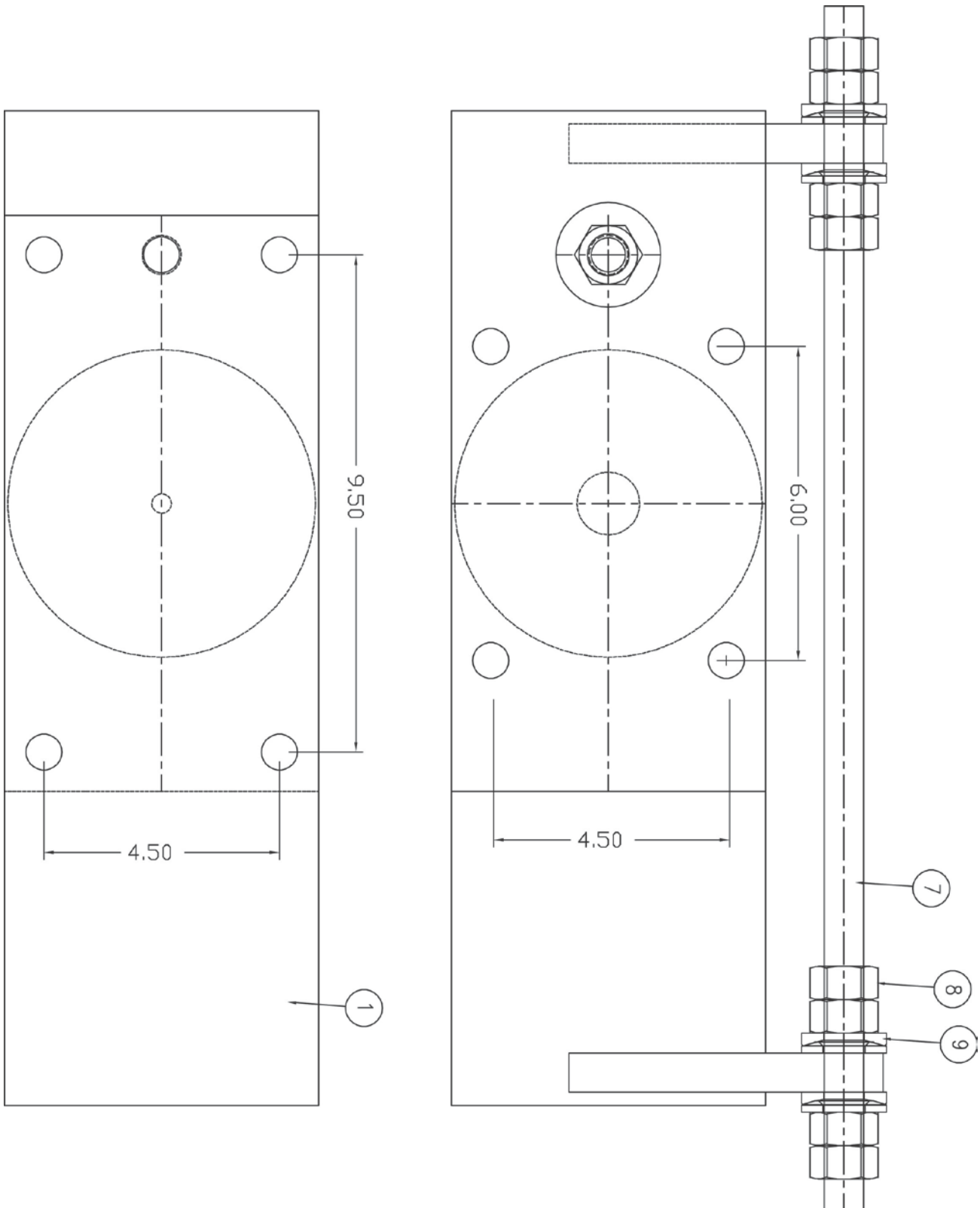

PARTS IDENTIFICATION, CONT.

SST25 Load Cell Stand (HBC25, Mild Steel and HBCS25, Stainless Steel)

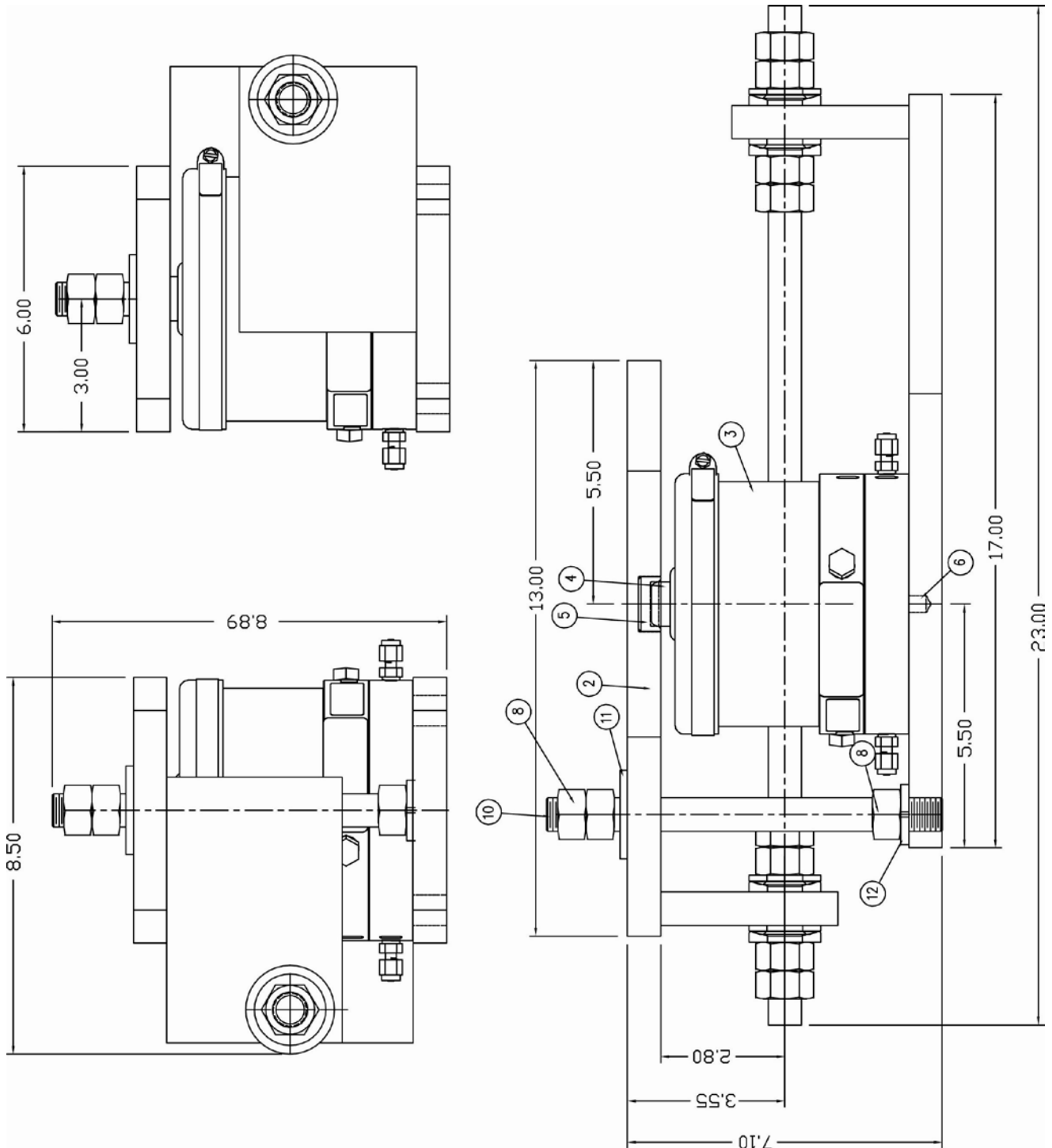

PARTS IDENTIFICATION, CONT.
SST25 Load Cell Stand (HBC25, Mild Steel)

ITEM NO.	QTY.	PART NUMBER	DESCRIPTION
1	1	1771-B277-1A	BASE PLATE
2	1	1771-B278-1A	TOP PLATE
3	1	SST25	LOAD CELL
4	-	-	-
5	1	1771-B219-08	LOAD BUTTON, 1 1/4 DIA 17-4 S.S.
6	1	6020-0517	DOWEL PIN, 3/8 DIA X 3/4 LONG (S.S.)
7	1	1771-B271-18	CHECK ROD HORIZ. 3/4-16UNF X 23" W/6" THD BOTH ENDS
8	11	6013-0188	NUT HEX 3/4-16 UNF Z/P
9	4	3501-B107-0A	WASHER SPHERICAL .781
10	1	1771-B275-18	CHECK BOLT VERT. 3/4-16 UNF X 9" W/2" THD BOTH ENDS
11	1	6024-0018	WASHER FLAT 3/4" Z/P
12	1	6024-0054	WASHER LOCK 3/4" Z/P

PARTS IDENTIFICATION, CONT.
SST25 Load Cell Stand (HBCS25, Stainless Steel)

ITEM NO.	QTY.	PART NUMBER	DESCRIPTION
1	1	1771-B277-0A	BASE PLATE
2	1	1771-B278-0A	TOP PLATE
3	1	SST25	LOAD CELL
4	-	-	-
5	1	1771-B219-08	LOAD BUTTON, 1 1/4 DIA 17-4 S.S.
6	1	6020-0517	DOWEL PIN, 3/8 DIA X 3/4 LONG (S.S.)
7	1	1771-B271-08	CHECK ROD HORIZ. 3/4-16UNF X 23" W/6" THD BOTH ENDS (S.S.)
8	11	6013-0186	NUT HEX 3/4-16 UNF (S.S.)
9	4	1771-B272-0A	WASHER SPHERICAL .781
10	1	1771-B275-08	CHECK BOLT VERT. 3/4-16 UNF X 9" W/2" THD BOTH ENDS (S.S.)
11	1	6024-1499	WASHER FLAT 3/4" S.S.
12	1	6024-1489	WASHER LOCK 3/4" S.S.

PARTS IDENTIFICATION

SST50 Load Cell Assembly

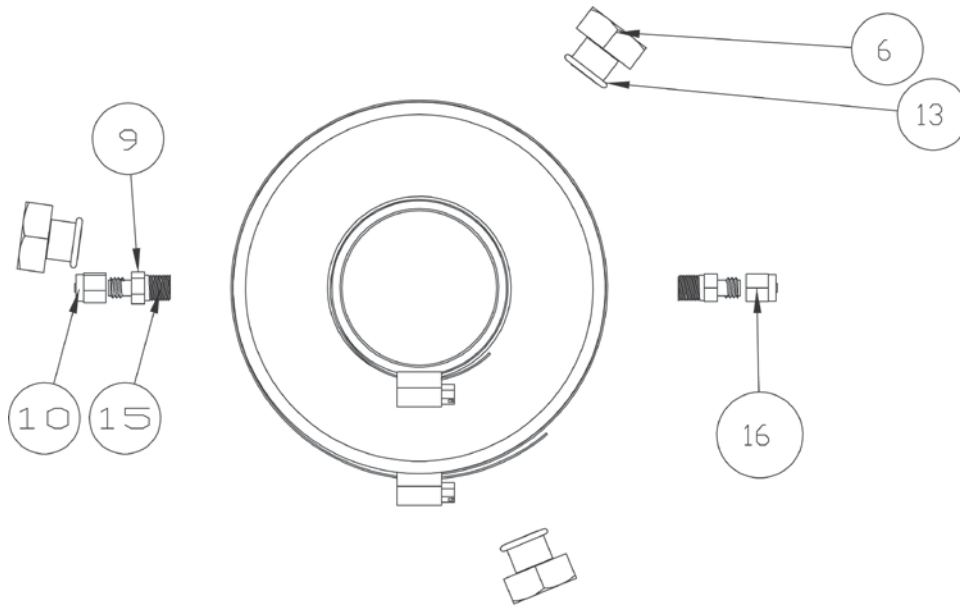

EXPLODED TOP VIEW

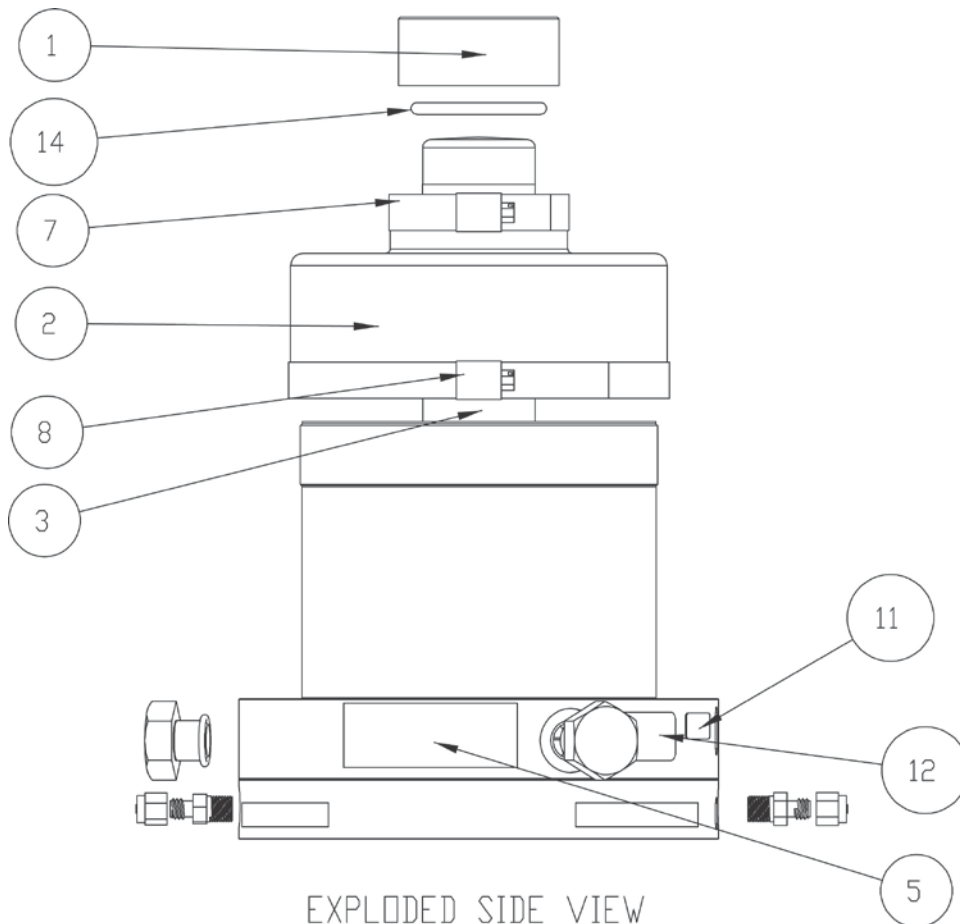

EXPLODED SIDE VIEW

PARTS IDENTIFICATION, CONT.

SST50 Load Cell Assembly

ITEM NO.	QTY.	PART NUMBER	DESCRIPTION
1	2	1771-B109-08	LOAD CUP
2	1	1771-B115-08	RUBBER BOOT
3	1	1771-C110-08	LOAD POST
4	1	1771-D116-0A	LOAD CELL WELDMENT FOR SST50
5	1	5930-B106-08	CARDINAL LOGO
6	3	6007-0115	BOLT HEX HD 5/8 X 0.5 NYLON
7	1	6028-0072	HOSE CLAMP, 1 13/16" – 2 3/4"
8	1	6028-0073	HOSE CLAMP, 5 5/8" – 8 1/2"
9	2	6031-0500	CONNECTOR, MALE 1/8" OD – 1/8" MNPT S.S.
10	1	6031-0502	PLUG FITTING 1/8" BRASS
11	1	6600-0650	LABEL HIGH TEMP INVENTORY TRACKING .37 X .90
12	1	6600-0653	SER. TAG 3/4 X 1 1/2" SILVER MYLAR
13	3	6650-0114	O-RING 5/8 ID X 13/16 OD X 3/32 THK VITON
14	2	6650-1055	O-RING 1.75 ID X 2.125 OD X .187 DIA BUNA-
15	.01	6560-1127	ADHESIVE LOCTITE 545 THREAD SEALANT
16	1	6031-0521	FITTING, STAINLESS 1/8" PLUG

PARTS IDENTIFICATION, CONT.

SST50 Load Cell Support Assembly

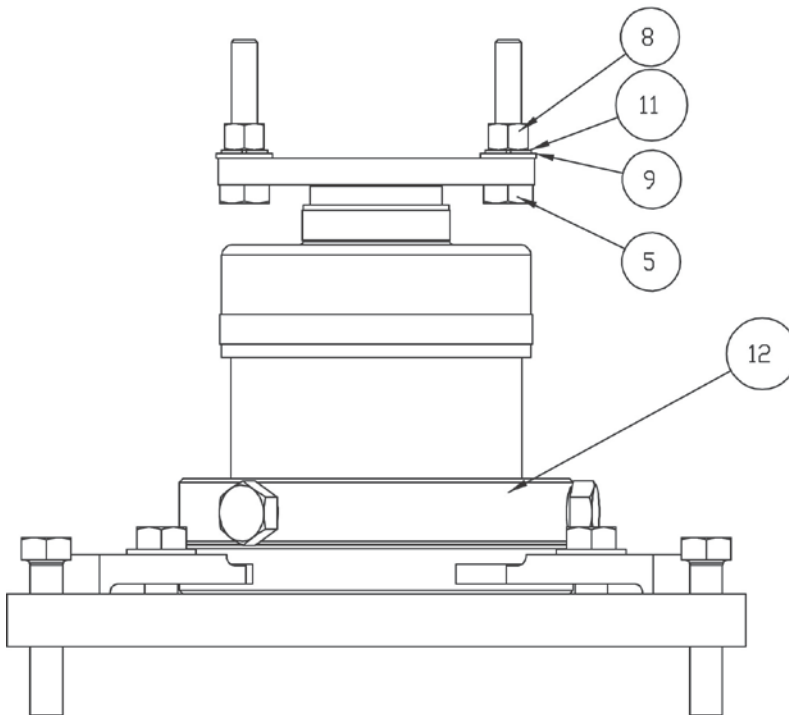
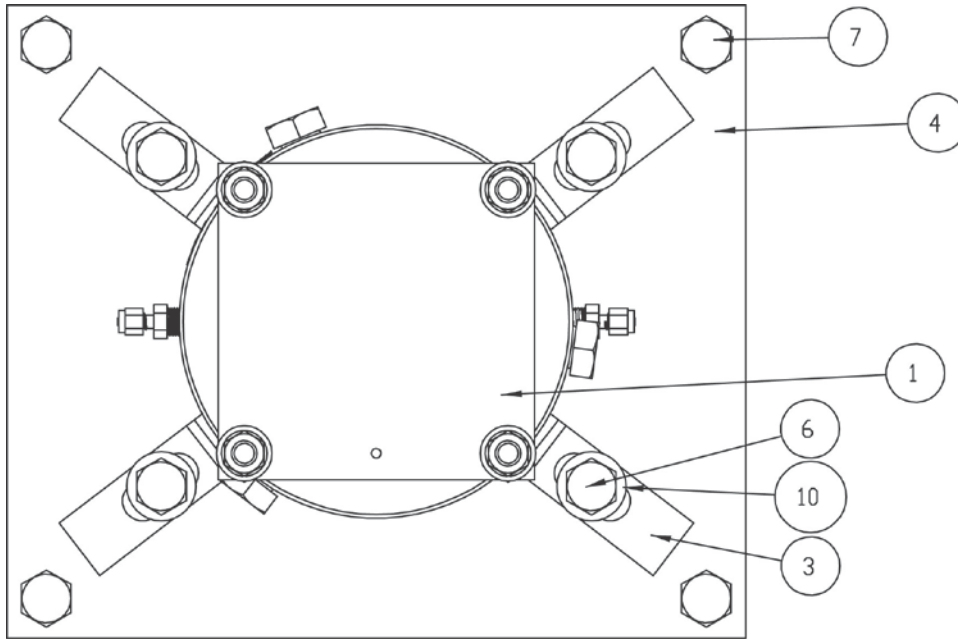

PARTS IDENTIFICATION, CONT.

SST50 Load Cell Support Assembly

ITEM NO.	QTY.	PART NUMBER	DESCRIPTION
1	1	0143-B004	TOP PLATE
2			
3	4	1771-B043-08	CLAMP
4	1	1771-C094-08	GROUT PLATE
5	4	6007-0020	BOLT HEX HD 1/2-13 X 2 3/4" UNC-2A GRADE 5
6	4	6007-0159	BLT HEX HD 5/8-11 X 1 1/2"UNC-2A G2 Z/P
7	4	6007-0230	BLT HEX HD 5/8-11 X 3" TAP BOLT GRADE 5
8	4	6013-0085	1/2-13 HEX STD NUT
9	4	6024-0012	1/2 FLAT WASHER
10	4	6024-0015	5/8 FLAT WASHER
11	4	6024-0048	1/2 SPLIT LOCK
12	1	SST50	HYDRAULIC LOAD CELL, 50K LB CAPACITY

PARTS IDENTIFICATION, CONT.

SST75 Load Cell Assembly

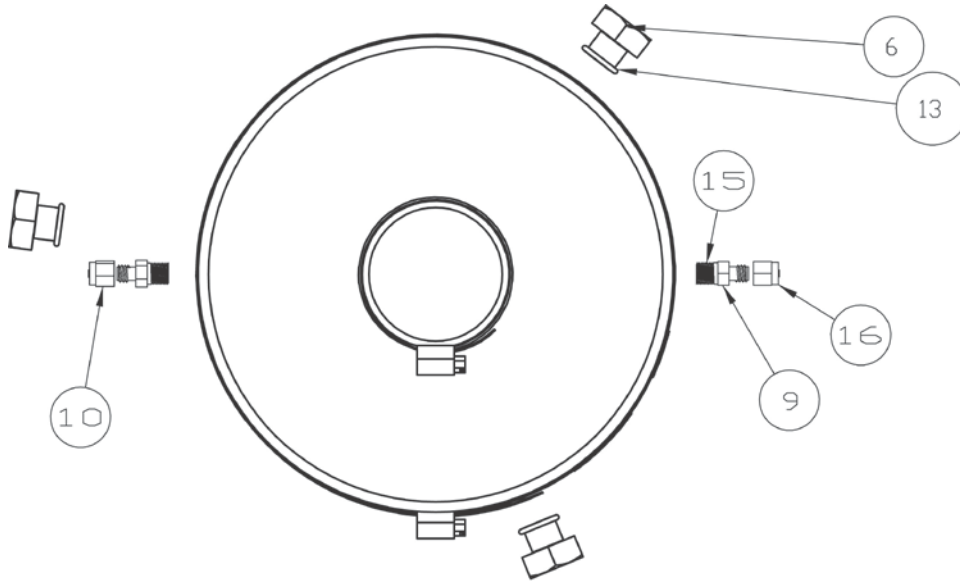

EXPLODED TOP VIEW

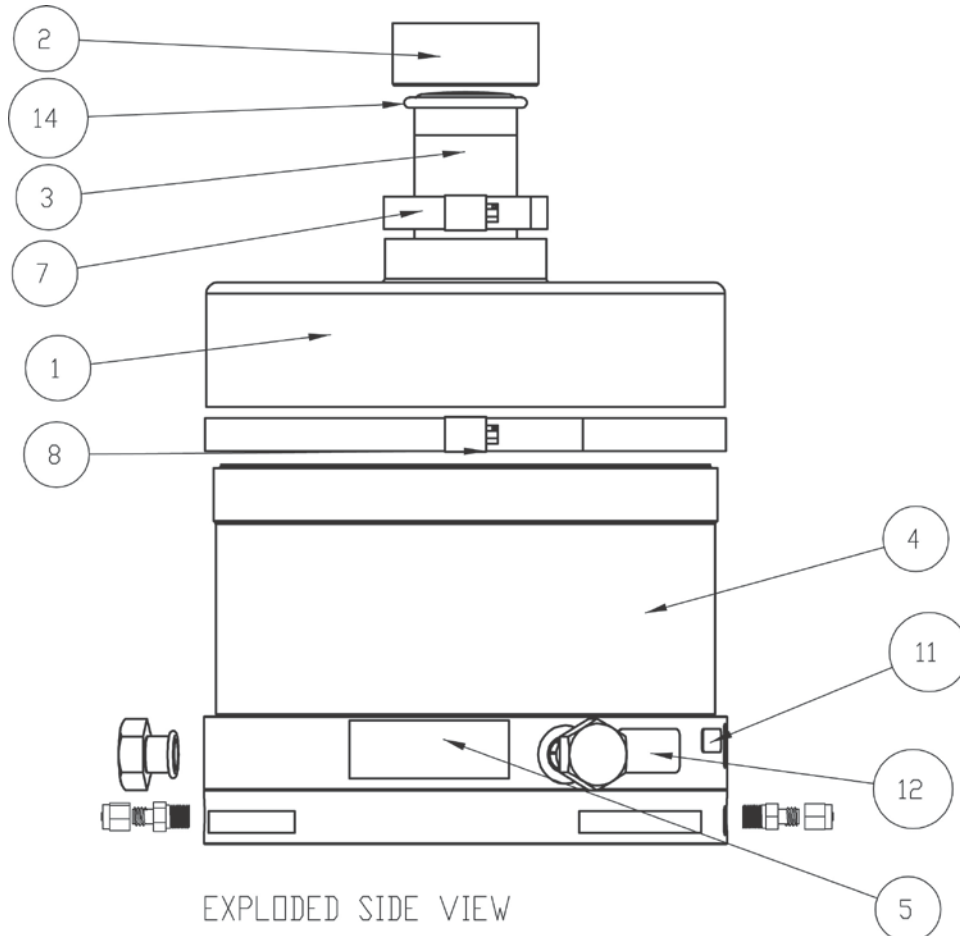

EXPLODED SIDE VIEW

PARTS IDENTIFICATION, CONT.

SST75 Load Cell Assembly

ITEM NO.	QTY.	PART NUMBER	DESCRIPTION
1	1	1771-B106-18	RUBBER BOOT FOR SST75/100
2	2	1771-B109-08	LOAD CUP
3	1	1771-C110-08	LOAD POST
4	1	1771-D040-0A	LOAD CELL WELDMENT FOR SST75
5	1	5930-B106-08	CARDINAL LOGO
6	3	6007-0115	BOLT HEX HD 5/8-11 X 0.5 NYLON
7	1	6082-0072	HOSE CLAMP, 1 13/16" – 2 3/4"
8	1	6028-0074	HOSE CLAMP, 7 1/8" – 10"
9	2	6031-0500	CONNECTOR, MALE
10	2	6031-0502	PLUG FITTING 1/8" BRASS
11	1	6600-0650	LABEL HIGH TEMP INVENTORY TRACKING .37 X .90
12	1	6600-0653	SER. TAG 3/4 X 1 1/2" SILVER MYLAR
13	3	6650-0114	O-RING 5/8 ID X 13/16 OD X 3/32 THK VITON
14	2	6650-1055	O-RING 1.75 ID X 2.125 OD X .187 DIA BUNA-
15	.01	6560-1127	ADHESIVE LOCTITE 545 THREAD SEALANT
16	1	6031-0521	FITTING, STAINLESS 1/8" PLUG

PARTS IDENTIFICATION, CONT.

SST75 Load Cell Support Assembly

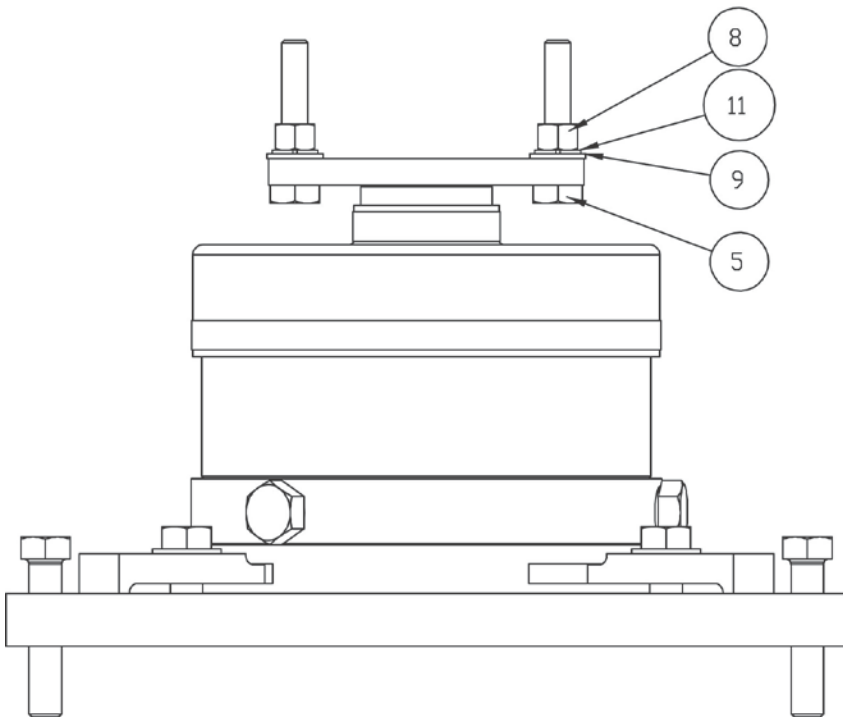
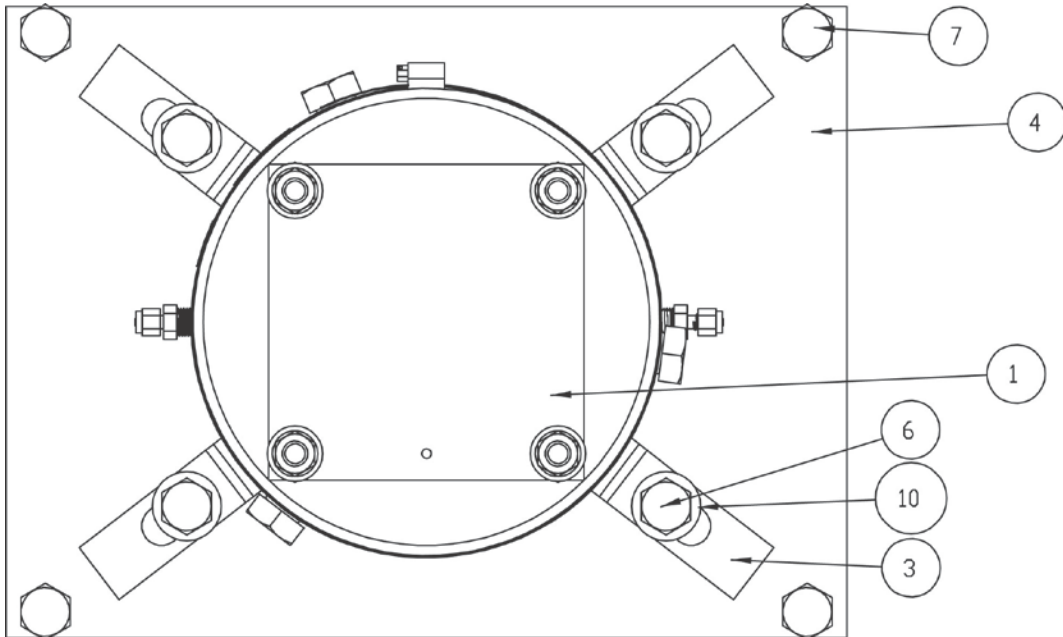

PARTS IDENTIFICATION, CONT.

SST75 Load Cell Support Assembly

ITEM NO.	QTY.	PART NUMBER	DESCRIPTION
1	1	0143-B004	TOP PLATE
2			
3	4	1771-B043-08	CLAMP
4	1	1771-C042-08	GROUT PLATE
5	4	6007-0020	BOLT HEX HD 1/2-13 X 2 3/4" UNC-2A GRADE 5
6	4	6007-0159	BLT HEX HD 5/8-11 X 1 1/2"UNC-2A G2 Z/P
7	4	6007-0230	BLT HEX HD 5/8-11 X 3" TAP BOLT GRADE 5
8	4	6013-0085	1/2-13 HEX STD NUT
9	4	6024-0012	1/2 FLAT WASHER
10	4	6024-0015	5/8 FLAT WASHER
11	4	6024-0048	1/2 SPLIT LOCK
12	1	SST75	HYDRAULIC LOAD CELL, 75K LB CAPACITY

PARTS IDENTIFICATION

SST100 Load Cell Assembly

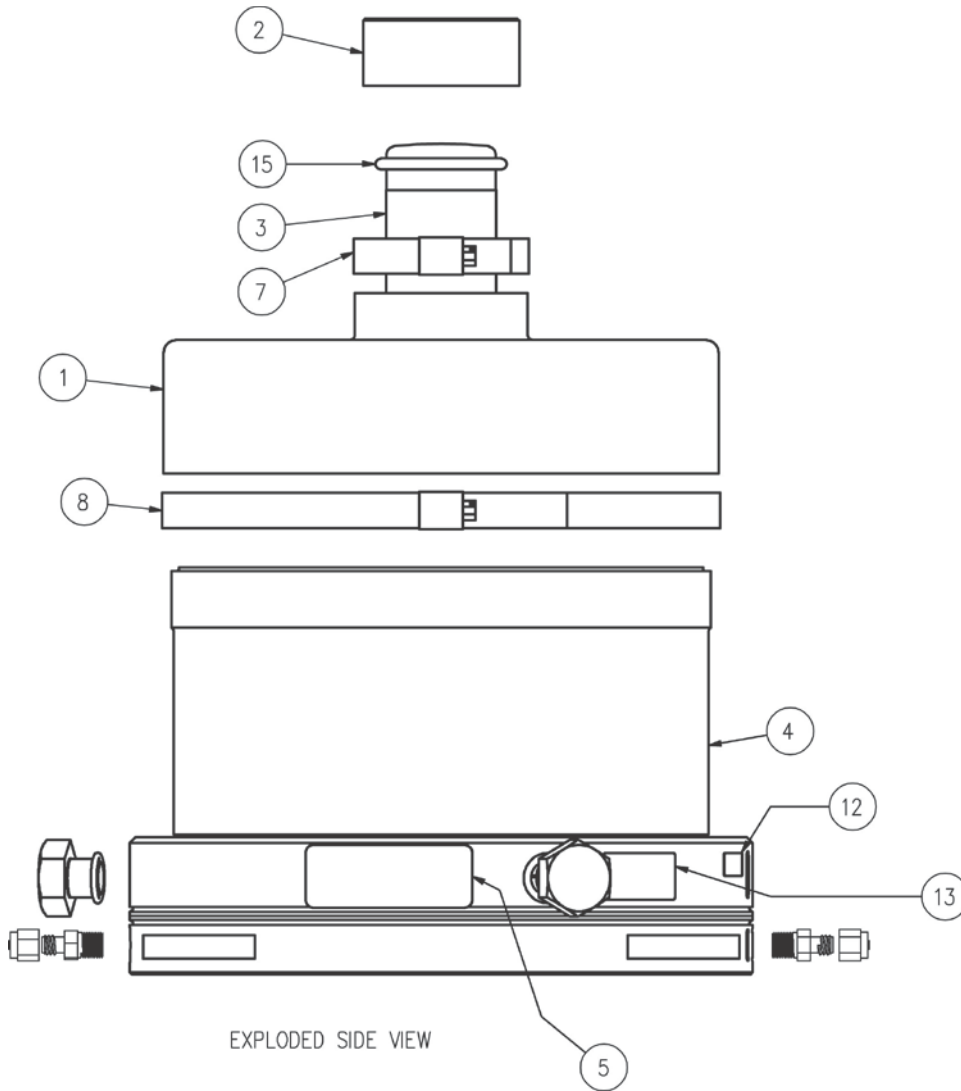

PARTS IDENTIFICATION, CONT.

SST100 Load Cell Assembly

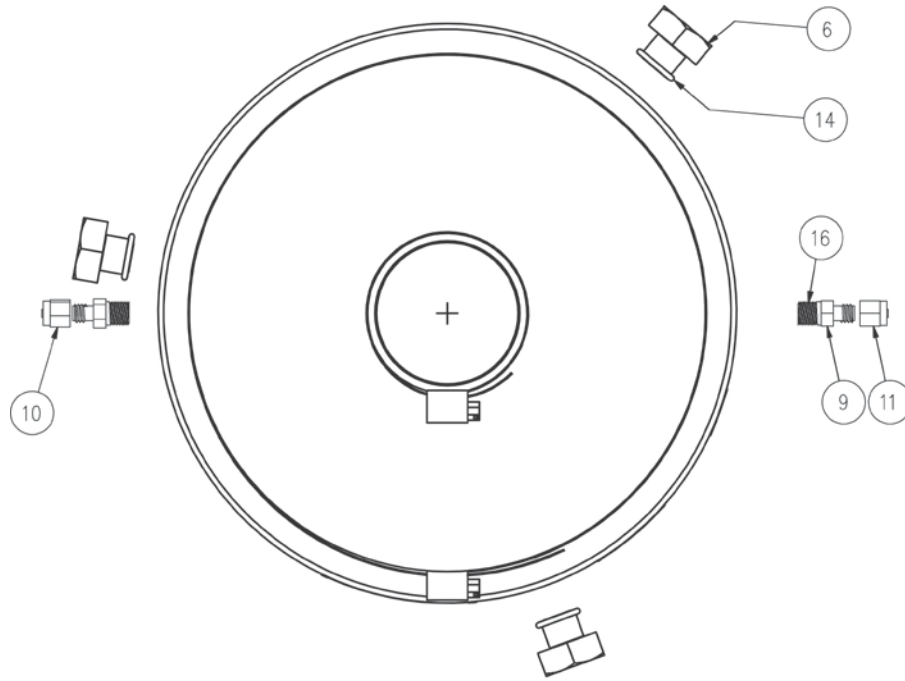

EXPLODED TOP VIEW

ITEM NO.	QTY.	PART NUMBER	DESCRIPTION
1	1	1771-B106-18	RUBBER BOOT NEOPRENE 0.131 THICK DURO.
2	2	1771-B109-08	LOAD CUP
3	1	1771-C110-08	LOAD POST
4	1	1771-D330-0A	LOAD CELL WELDMENT FOR SST100
5	1	5930-B106-08	LABEL: CARDINAL LOGO W/WEB ADDRESS
6	3	6007-0115	BOLT HEX HD 5/8-11 X 0.5 NYLON
7	1	6082-0072	HOSE CLAMP, 1 13/16" – 2 3/4"
8	1	6028-0074	HOSE CLAMP, 7 1/8" – 10"
9	2	6031-0500	CONNECTOR, MALE
10	1	6031-0502	PLUG FITTING 1/8" BRASS
11	1	6031-0521	FITTING, STAINLESS 1/8" PLUG
12	1	6600-0650	LABEL HIGH TEMP INVENTORY TRACKING .37 X .90
13	1	6600-0653	SERIAL TAG 3/4 X 1 1/2" SILVER MYLAR
14	3	6650-0114	O-RING
15	2	6650-1055	O-RING
16	.01	6560-1127	ADHESIVE LOCTITE 545 THREAD SEALANT

PARTS IDENTIFICATION, CONT.

SST100 Load Cell Support Assembly

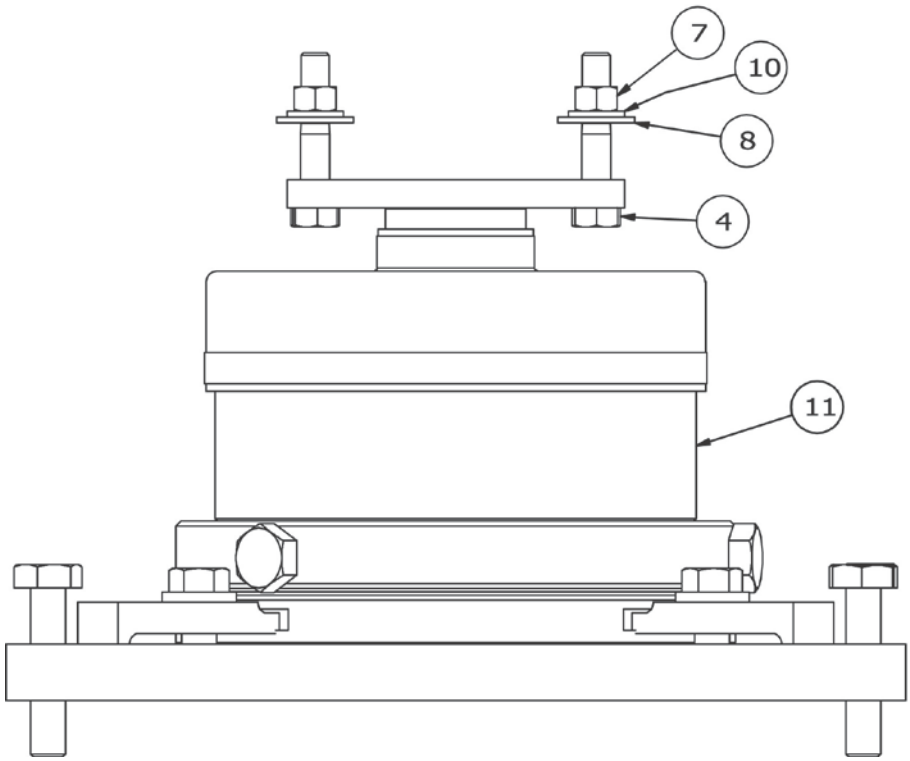
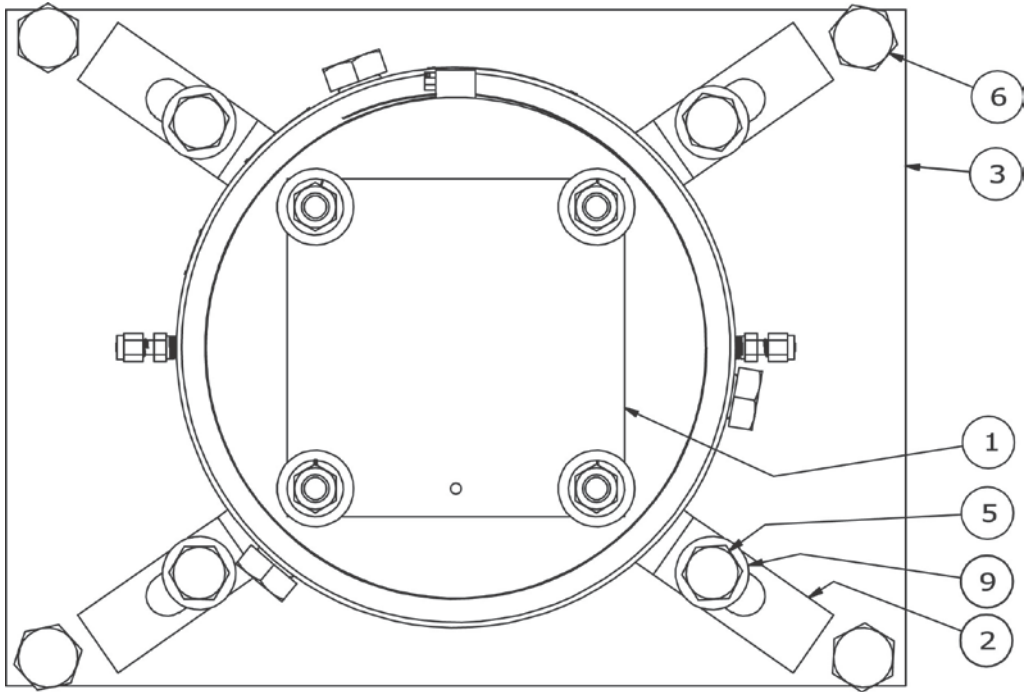

PARTS IDENTIFICATION, CONT.

SST100 Load Cell Support Assembly

ITEM NO.	QTY.	PART NUMBER	DESCRIPTION
1	1	0143-B004	TOP PLATE
2	4	1771-B043-08	CLAMP
3	1	1771-C042-08	GROUT PLATE
4	4	6007-0020	BOLT HEX HD 1/2-13 X 2 3/4" UNC-2A GRADE 5
5	4	6007-0159	BLT HEX HD 5/8-11 X 1 1/2"UNC-2A G2 Z/P
6	4	6007-0230	BLT HEX HD 5/8-11 X 3" TAP BOLT GRADE 5
7	4	6013-0085	1/2-13 HEX STD NUT
8	4	6024-0012	1/2 FLAT WASHER
9	4	6024-0015	5/8 FLAT WASHER
10	4	6024-0048	1/2 SPLIT LOCK
11	1	SST100	HYDRAULIC LOAD CELL, 100K LB CAPACITY

PARTS IDENTIFICATION, CONT.

3 & 4 Cell Totalizer Enclosure

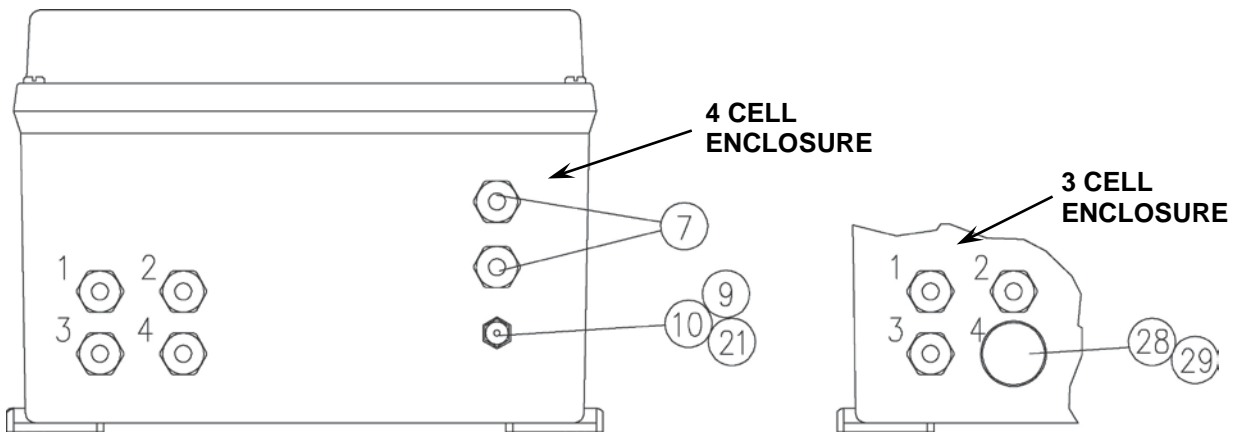
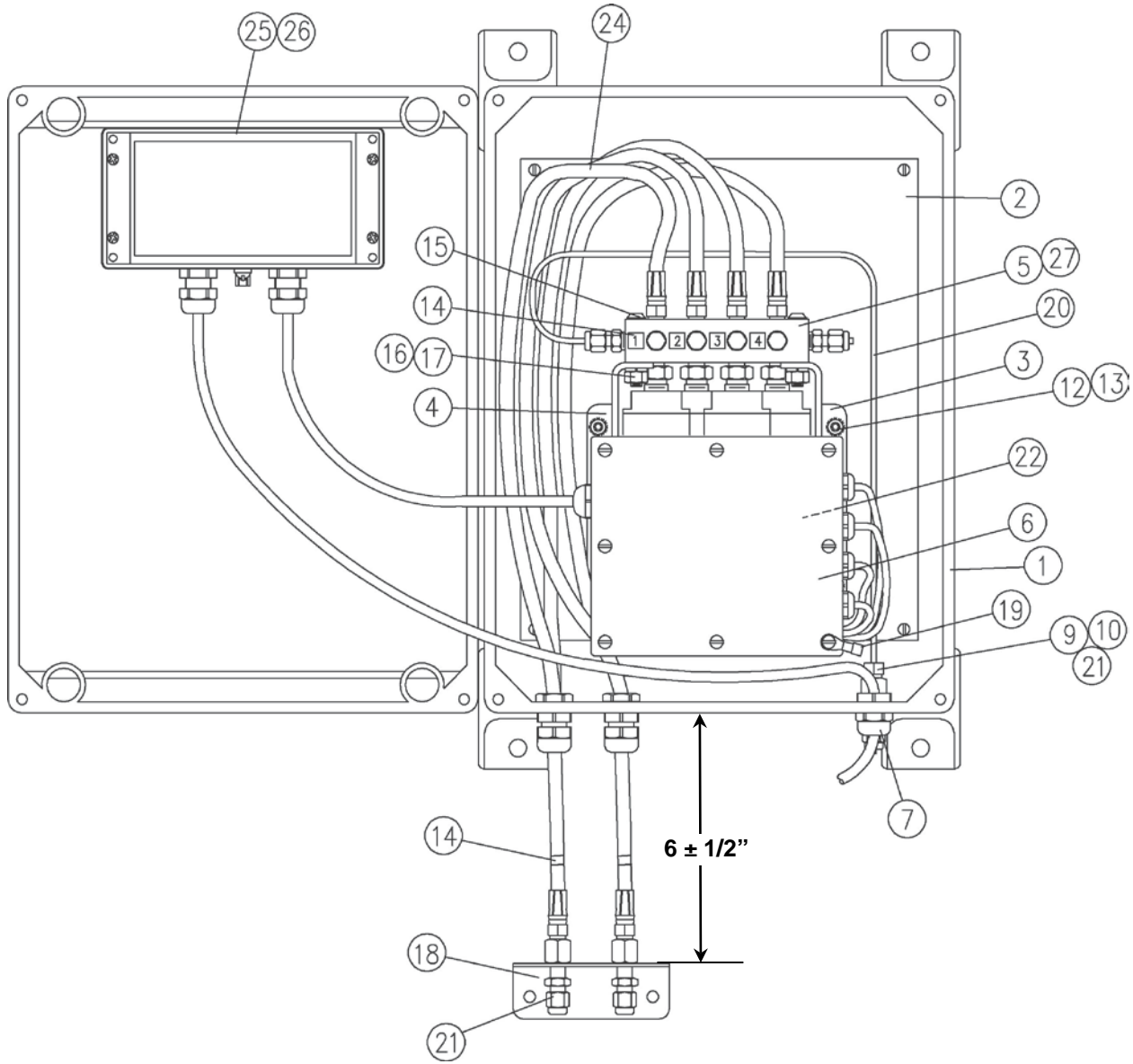

PARTS IDENTIFICATION, CONT.

3 & 4 Cell Totalizer Enclosure

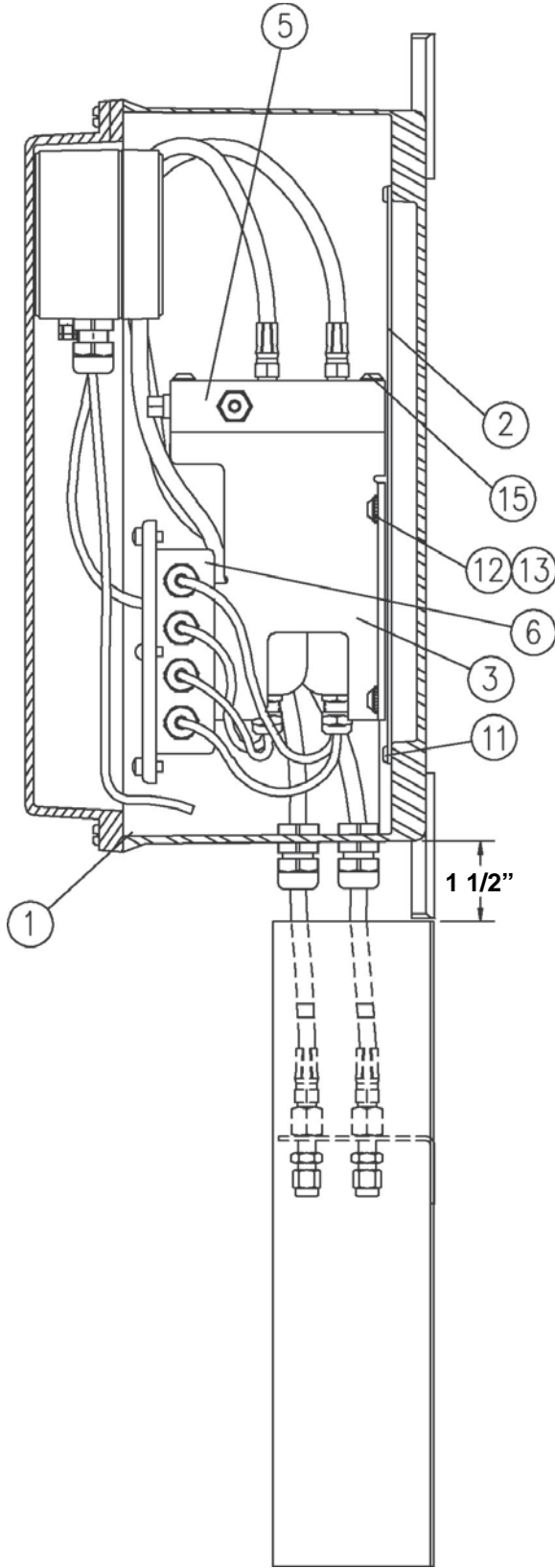

PARTS IDENTIFICATION, CONT.

3 & 4 Cell Totalizer Enclosure

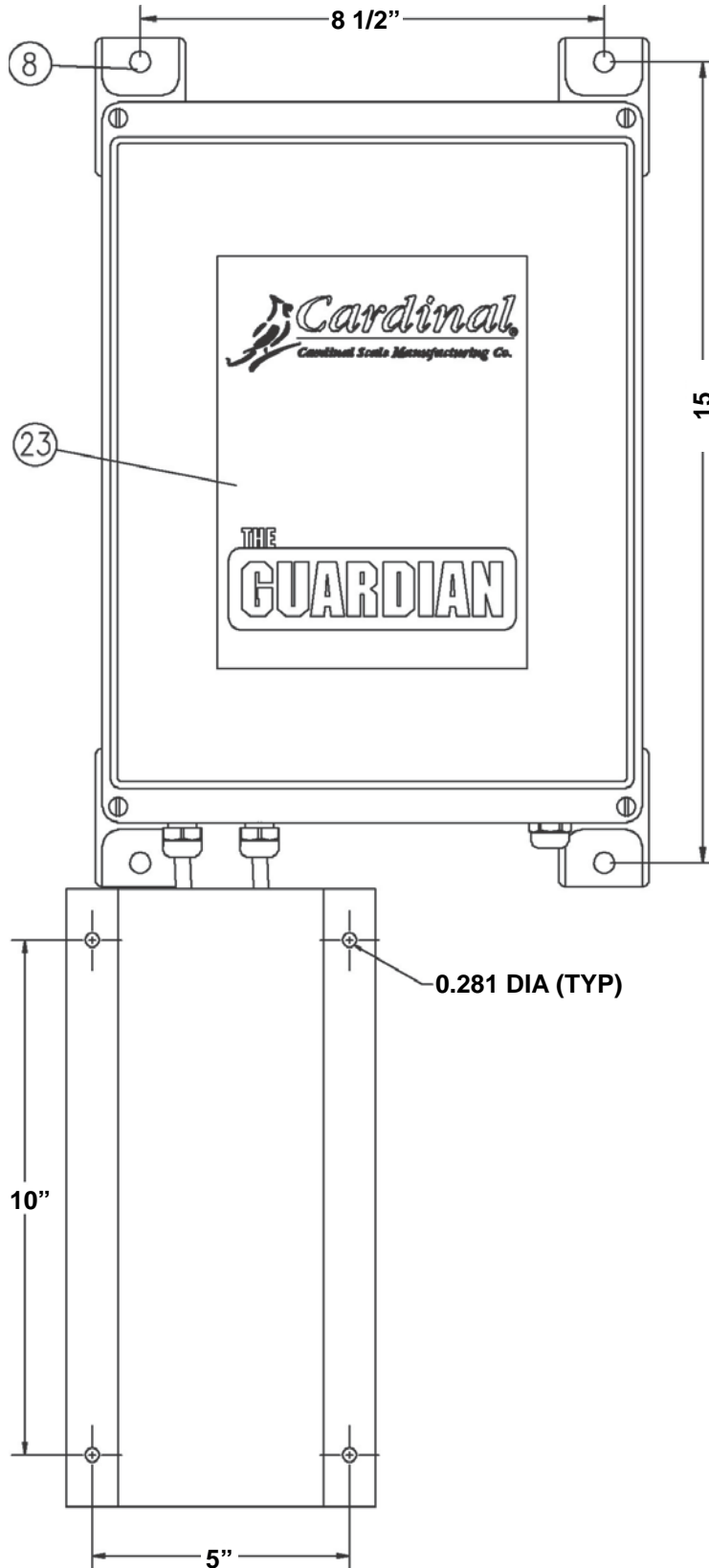

PARTS IDENTIFICATION, CONT.

3 & 4 Cell Totalizer Enclosure

ITEM NO.	QTY.	PART NUMBER	DESCRIPTION
1	1	1780-D049-08	ENCLOSURE
2	1	1780-C051-08	SUBPANEL - TOTALIZER
3	1	1780-D050-08	BRACKET
4	1	1780-D050-18	BRACKET
5	1	1772-C014-0A	VALVE BLOCK ASSY, 4 CELL SYSTEM
6	1	1780-C052-0A	J-BOX TRIM ASSY
7	2	6610-2248	GLAND CONNECTOR
8	1	6540-0331	MOUNTING FEET
9	1	6031-0515	FITTING, BRASS
10	1	6031-0507	JAM NUT, BRASS
11	4	6021-1020	RHMS, #10-32UNF-2A X 3/8"
12	4	6021-1004	BHCS, #10-32 X 1/2"
13	4	6024-0049	WASHER LOCK, EXT TOOTH #10 TYPE A Z-PL
14	.2	6980-0139	WIRE MARKER #1-45 (10 SHEETS/BOOKLET)
15	4	6021-1533	BHCS, 1/4-20UNC-2A X 1 1/2"
16	4	6024-0039	WASHER LOCK, HELICAL 1/4"
17	4	6013-0045	HEX NUT, 1/4-20UNC-2B
18	1	1780-C042-18	BULKHEAD BRACKET (4 CELL)
19	1	6610-2449	RING TERMINAL, 1/4 STUD 12-10 AWG
20	3'	6031-0506	COPPER TUBING
21	5	6031-0502	PLUG, BRASS
22	4	6021-1707	FHSCS, 1/4-28 X 1/2"
23	1	1780-B028-18	LABEL: LOGO & GUARDIAN
24	4	1780-B053-0A	SHORTER HYD. HOSE (4 CELL SYSTEM)
	3	1780-B053-0A	SHORTER HYD. HOSE (3 CELL SYSTEM)
25	1	3502-C520-0A	TRANS SUPP. BOX
26	A/R	6710-1017	TAPE (AS REQUIRED)
27	1	1772-C014-1A	VALVE BLOCK ASSY, 3 CELL SYSTEM
28	1	3502-B217-0A	HOLE PLUG
29	A/R	6560-0041	SILICON SEALER (AS REQUIRED)

CELL OUTPUT CALIBRATION WORKSHEET

Cell #	Dead Load Output	-	Zero Balance Output	=	Circuit Gain
Cell #1	_____	-	_____	=	_____
Cell #2	_____	-	_____	=	_____
Cell #3	_____	-	_____	=	_____
Cell #4	_____	-	_____	=	_____

STATEMENT OF LIMITED WARRANTY

WARRANTY TERMS

Cardinal Scale Manufacturing Company warrants the equipment we manufacture against defects in material and workmanship. The length and terms and conditions of these warranties vary with the type of product and are summarized below:

PRODUCT TYPE	TERM	MATERIAL AND WORKMANSHIP	LIGHTNING DAMAGE See note 9	WATER DAMAGE See note 7	CORROSION See note 4	ON-SITE LABOR	LIMITATIONS AND REQUIREMENTS
WEIGHT INDICATORS	90 DAY REPLACEMENT ----- 1 YEAR PARTS	YES	YES	YES	YES	NO	1, 2, 3, 5, 6 A, B, C, D
LOAD CELLS (Excluding Hydraulic)	1 YEAR	YES	YES	YES	YES	NO	1, 2, 3, 5, 6 A, B, C, D
HYDRAULIC LOAD CELLS (When purchased with Guardian Vehicle Scale)	LIFETIME	YES	YES	YES	YES	90 DAYS	1, 5, 6, 8 A, B, C, D
HYDRAULIC LOAD CELLS (When purchased separately)	10 YEARS	YES	YES	YES	YES	NO	1, 5, 6, 8, 9 A, B, C, D
VEHICLE SCALE (Deck and Below Excl. PSC Series)	5 YEARS	YES	YES	YES	YES	90 DAYS	1, 2, 3, 5, 6 A, B, C, D, E
LSC SCALE (Deck and Below)	3 YEARS	YES	YES	YES	YES	90 DAYS	1, 2, 3, 5, 6, 11 A, B, C, D
GUARDIAN FLOOR SCALES	10 YEARS	YES	YES	YES	YES	NO	1, 2, 3, 5, 6, 9, 10 A, B, C, D
ALL OTHER CARDINAL PRODUCTS	1 YEAR	YES	YES	YES	YES	NO	1, 2, 5, 6 A, B, C, D, E
REPLACEMENT PARTS	90 DAYS	YES	YES	YES	YES	NO	1, 2, 4, 5, 6 A, B, C, D
SWIM AND 760 SERIES VEHICLE SCALES	1 YEAR	YES	YES	YES	YES	90 DAYS	1, 2, 5, 6 A, B, C, D
SOFTWARE	90 DAYS	YES	N/A	N/A	N/A	NO	1, 6 B, C, D
CONVEYOR BELT SCALES (including Belt-Way)	1 YEAR	YES	YES	YES	YES	NO	1, 2, 3, 5, 6 A, B, C, D, E, F



CARDINAL

Ph. (800) 441-4237
E-mail: cardinal@cardet.com
102 E. Daugherty
Webb City, MO 64870

04/24
Printed in USA
315-WARRANTY-CAR-M

APPLICABLE LIMITATIONS AND REQUIREMENTS

1. This warranty applies only to the original purchaser. The warranty does not apply to equipment that has been tampered with, defaced, damaged, or had repairs or modifications not authorized by Cardinal or has had the serial number altered, defaced or removed.
2. This warranty is not applicable to equipment that has not been grounded in accordance with Cardinal's recommendations.
3. This equipment must be installed and continuously maintained by an authorized Cardinal / Belt-Way dealer.
4. Applies only to components constructed from stainless steel.
5. This warranty does not apply to equipment damaged in transit. Claims for such damage must be made with the responsible freight carrier in accordance with freight carrier regulations.
6. Warranty term begins with date of shipment from Cardinal.
7. Only if device is rated NEMA 4 or better or IP equivalent.
8. Lifetime warranty applies to damages resulting from water, lightning, and voltage transients and applies only to the hydraulic load cell structure itself (does not include pressure transducers, rubber seals, o-rings, and associated wiring).
9. 10-Year prorated warranty on hydraulic load cells.
10. 1-Year warranty for scale structure.
11. PSC models' warranty coverage applies only to agricultural installations on farms up to 3,000 acres (LSC models not limited in this manner).
12. Load cell kits MUST be installed in accordance with Cardinal Scale instructions. Failure to follow these instructions will void the warranty.

EXCLUSIONS

- A.) This warranty does not include replacement of consumable or expendable parts. The warranty does not apply to any item that has been damaged due to unusual wear, abuse, improper line voltage, overloading, theft, fire, water, prolonged storage or exposure while in purchaser's possession or acts of God unless otherwise stated herein.
- B.) This warranty does not apply to peripheral equipment not manufactured by Cardinal. This equipment will normally be covered by the equipment manufacturer's warranty.
- C.) This warranty sets forth the extent of our liability for breach of any warranty or deficiency in connection with the sale or use of our product. Cardinal will not be liable for consequential damages of any nature, including but not limited to loss of profit, delays or expenses, whether based on tort or contract. Cardinal reserves the right to incorporate improvements in material and design without notice and is not obligated to incorporate said improvements in equipment previously manufactured.
- D.) This warranty is in lieu of all other warranties expressed or implied including any warranty that extends beyond the description of the product including any warranty of merchantability or fitness for a particular purpose. This warranty covers only those Cardinal products installed in the forty-eight contiguous United States and Canada.
- E.) This warranty does not cover paint coatings due to the variety of environmental conditions.
- F.) Do not cut load cell cables on load cells returned for credit or warranty replacement. Cutting the cable will void the warranty.
- G.) Software is warranted only for performance of the functions listed in the software manual and/or the Cardinal proposal.
- H.) The software warranty does not cover hardware. Warranties on hardware are provided from the hardware vendor only.
- I.) The software warranty does not cover interfacing issues to non-Cardinal supplied hardware.
- J.) The software warranty does not include automatic software upgrades unless purchased separately.



Ph. (800) 441-4237
E-mail: cardinal@cardet.com
102 E. Daugherty
Webb City, MO 64870

04/24
Printed in USA
315-WARRANTY-CAR-M

Cardinal Scale Mfg. Co.

102 E. Daugherty, Webb City, MO 64870 USA

Ph: 417-673-4631 or 1-800-641-2008

Fax: 417-673-2153

www.cardinalscale.com

Technical Support: 1-866-254-8261

E-mail: tech@cardet.com

Printed in USA

1780-M057-O1 Rev C 11/14