



CARDINAL®

**Floor Hugger
Electronic Low-Profile
Platform Scale
Owner's Manual**

INTRODUCTION

Your low profile platform scale is designed and manufactured with quality and reliability. Optional inclined ramps may be installed for easy approach and exit of scale. Four electronic load cells support the scale platform and are connected at a centrally located junction box where calibration adjustments may be made. These load cells are self-checking and environmentally sealed.

A lifting eye bolt is shipped with selected scales and should be conveniently stored, along with the shipping bolts, after completion of scale installation. The shipping bolts and lifting eye bolt will need to be re-installed if scale is relocated in the future.

Your low profile platform scale has been factory calibrated to perform within the specifications set forth in Handbook #44 issued by the United States Department of Commerce, National Institute of Standards & Technology, as a "legal for trade" weighing device. If re-calibration is required upon completion of installation, such procedures should be performed by a scale technician familiar with calibration and performance requirements of Handbook #44.

This manual provides instruction for unpacking, installing and calibration of your scale. A Trouble Shooting Guide was written so you may isolate or correct a problem before calling a scale technician.

Please read this manual thoroughly and pay special attention to the warning symbols.

COPYRIGHT

All rights reserved. Reproduction or use, without express permission, of editorial or pictorial content, in any manner, is prohibited. No patent liability is assumed with respect to the use of the information contained herein.

TABLE OF CONTENTS

Introduction.....	1
Installation	2
Calibration Procedure.....	3
Trim Adjustment	4
Trouble Shooting Guide	5
Interconnection Diagram	6

FCC COMPLIANCE STATEMENT



This equipment generates uses and can radiate radio frequency energy and if not installed and used in accordance with the instructions in this manual, may cause interference to radio communications. It has been tested and found to comply with the limits for a Class A computing device pursuant to Subpart J of Part 15 of FCC Rules, which are designed to provide reasonable protection against such interference when operated in a commercial environment. Operation of this equipment in a residential area is likely to cause interference in which case the user, at his own expense, will be required to take whatever measures may be required to correct the interference.

DISCLAIMER

While every precaution has been taken in the preparation of this book, we assume no responsibility for errors or omissions. Neither is any liability assumed for damages resulting from the use of the information contained herein. All instructions and diagrams have been checked for accuracy and ease of application; however, success and safety in working with tools depend to a great extent upon the individual accuracy, skill and caution. For this reason, we are not able to guarantee the result of any procedure contained herein. Nor can we assume responsibility for damage to property or injury to persons occasioned from the procedures. Persons engaging the procedures do so entirely at their own risk.

Serial Number _____
Date of Purchase _____
Purchased From _____

RETAIN THIS INFORMATION FOR FUTURE USE

PRECAUTIONS	
Before using this indicator, read this manual and pay special attention to all "WARNING" symbols:	
	
IMPORTANT	ELECTRICAL WARNING

INSTALLATION

The following section outlines procedures for unpacking and installation of your scale.

Read this entire section carefully before attempting to unpack or install this scale.



FIGURE No. 1

Inspect the shipping container for any signs of damage such as exterior dents and scratches. It is the responsibility of the purchaser to file all claims with the shipping company for damages or loss incurred during transit, unless this responsibility has been accepted by the Seller in its proposal. Scale should remain packed until you are ready to install it, protecting it while being stored.



Remove shipping bands and packing material. Make certain "all" packing material is removed. Remove wooden box containing load cell cable from pallet. Place on scale platform until further instructions are given.



BE CERTAIN scale location is level and free of debris.

Using the lifting eye bolt provided, move scale to final location (selected scales).

DO NOT push or slide scale, damage to load cells may result.

Once you have positioned the scale in its final location, shim or grout under each corner plate to level scale. Make certain weight is evenly distributed over each of the four corner plates.

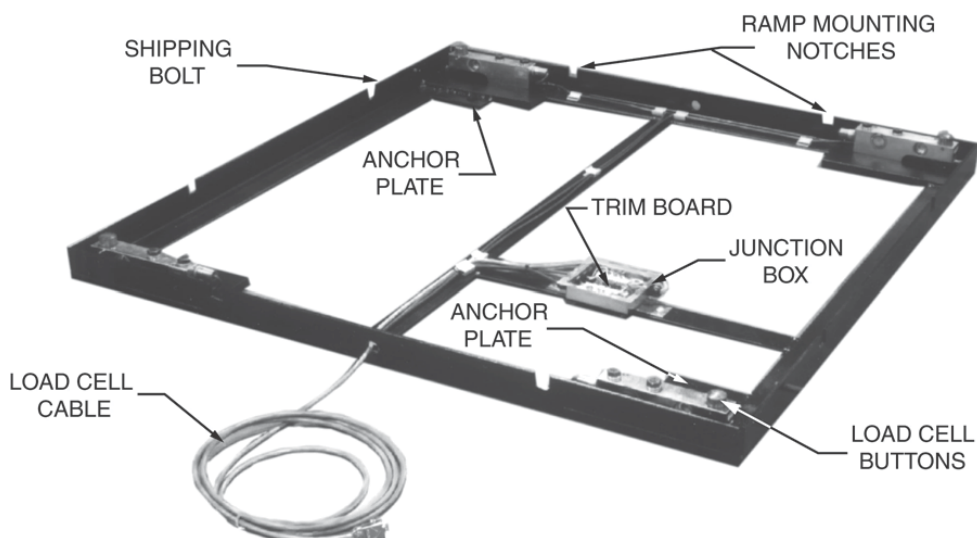

Figure No. 2

INSTALLATION Continued

The lower frame assembly (as seen in Figure No. 2) contains shipping bolts used to keep the platform secure during transit. These shipping bolts must be removed, (either 2 or 4 depending on the model purchased) and conveniently stored for re-installation before moving scale.

We recommend the scale be fastened to the floor using the holes found in the scale anchoring plates. To gain access to the anchoring plates, the weighbridge must be removed. Remove all shipping bolts (if not already removed), and lift the weighbridge off the lower frame using the eye bolt. It is the responsibility of the customer to provide anchoring hardware.



Care should be taken when moving weighbridge so as not to move lower frame, thus requiring leveling of scale again.

Once the scale has been properly anchored, re-install weighbridge by lowering onto lower frame. Place weighbridge bearing plates over load cell buttons.

Ramp mounting notches are provided on all four sides of your scale base, allowing scale ramps to be placed on any or all sides. Insert ramp hooks into their respective mounting holes, making sure ramps rest on floor. Be sure ramps do not touch weighbridge.

Remove load cell cable from wooden box, connect cable to weight indicating instrument, following instructions provided in instrument manual.



Make certain cable is not placed near heating or cooling ducts, relay panels, ovens or other types of electrical equipment. All cables should be routed out of the way of normal traffic and secured to prevent accidental damage to operator and/or instruments.

After connection has been made, power-up and zero weight indicator according to indicator manual directions.

CALIBRATION PROCEDURE

Your scale was factory adjusted to $\pm .05$ percent accuracy at the factory. Minor changes in calibration due to shock and vibration encountered during shipping may necessitate re-calibration.



The following procedures require a known test weight; make certain test weight is accurate.

Place test weight or weights equal to 10 percent of the scales capacity on scale platform. Record the weight displayed. If displayed weight does not fall within this $\pm .05$ percent value of test weight, scale may need re-calibrated.



It should be noted that in addition to the $\pm .05\%$ tolerance $\pm 1/2$ graduation is added when connected to digital display.

Please check the following before proceeding:

Make certain proper installation procedures were followed.

Is debris near or under scale deck (such as packing material) restricting proper scale operation?



Calibration procedures should be performed by a qualified scale technician or someone familiar with scale calibration procedures.

CALIBRATION PROCEDURE Continued

Place test weight equal to ten percent of the scales capacity over each of the four load cells, one at a time. Record each displayed weight. If difference in displayed weight exceeds ± 0.05 percent of the test weight, trimming adjustments for your load cells must be performed. Refer to TRIM ADJUSTMENT Section for further instruction. If all four weight readings are within the allowable tolerance (± 0.05 percent of test weight), weight indicator should be re-calibrated in accordance with the indicator manual.

TRIM ADJUSTMENT

The purpose of adjusting trim is so the same weight reading will be displayed regardless of where the load is placed on the scale deck. All scales are corner trimmed before leaving the factory. In the event of re-calibration or load cell replacement, follow instructions below to re-trim corners. It is assumed the other three load cells are already corner sealed to agree with each other. If not, please refer to next page for further instruction.

1. Remove access plate located on scale deck.
2. Remove junction box access cover.
3. Refer to Figure No. 3 for load cell location reference.
4. Turn trim potentiometer for the load cell needing re-calibration clockwise 25 turns, or until a click is heard indicating the end of the potentiometer adjustment.
5. Place a test weight on each corner, one at a time, and record the displayed weight for each corner.
6. Place test weight on the corner with the highest reading and adjust the appropriate trim potentiometer until the weight reading agrees with the lowest reading obtained in Step 5.
7. Repeat Step 6 until all corners have the same weight reading.
8. Replace screws securing the junction box cover and access plate.

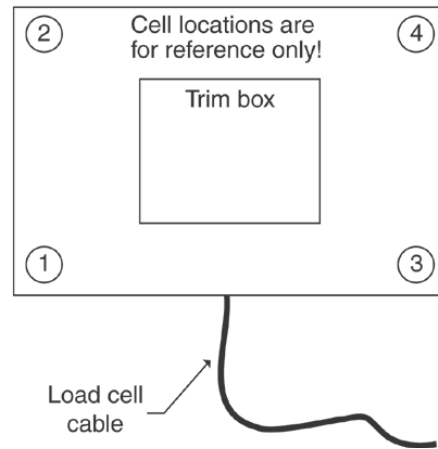

Figure No. 3

If two or more load cells must be replaced or scale needs an over-all resealing of each corner, these procedures should be followed.

1. Remove access plate located on scale deck. Remove junction box access cover.
2. Turn all potentiometers clockwise 25 turns or until a click is heard. Now turn all potentiometers counterclockwise 1 (one) turn.
3. Place test weight of at least 10 percent of scales capacity on each corner, one at a time, and record each displayed weight.
4. Place test weight on corner with the highest displayed weight and adjust appropriate trim potentiometer counter-clockwise until corner reading agrees with lowest weight reading.
5. Repeat Step No. 4 until all corners are equal.
6. Re-calibrate weight indicator following procedures in indicator manual.
7. Replace screws securing the junction box cover and access plate.

EXAMPLE:

	CORNER NO.			
1000 lb TEST WEIGHT	1	2	3	4
DISPLAYED WEIGHT READING	1020	1016	1017	1021

1. Place test weight on each corner, one at a time, and record each displayed weight.
2. Place test weight on corner no. 1 and adjust no. 1 trim potentiometer to reduce displayed weight to the lowest corner reading (No. 2 in example).
3. Repeat step 2 with corners no. 3 and 4 until all corners are in agreement.
4. Calibrate weight indicator following instructions provided in its manual.

TROUBLE SHOOTING GUIDE

If difficulty is encountered with the operation of the scale a visual check of the scale platform should be made to make certain operation is not restricted by foreign material, such as packing material, etc.

The following trouble shooting guide should prove useful in isolating and correcting a problem with the scale. If problem cannot be resolved with the use of this trouble shooting guide, contact a qualified scale technician for service.

PROBLEM	CAUSE	SOLUTION
Scale reads accurate weight to a point, but will not register beyond that point.	Obstruction between floor and bridge.	Remove obstruction.
Cannot obtain repeatable readings.	A. Scale not level B. Bad or improper wiring C. Bad load cell D. Bad trim circuit board	A. Level Scale B. Check wiring & solder connections C. Replace load cell D. Replace trim circuit board
One corner will not register correct weight.	Improper load cell mounting	Align and tighten load cell mounting bolts
Frame deflection observed when capacity loads are applied	Frame mounting plates not properly shimmed or grouted	Shim or Grout frame mounting plates so that the load is uniformly distributed over the area.

INTERCONNECTION DIAGRAM

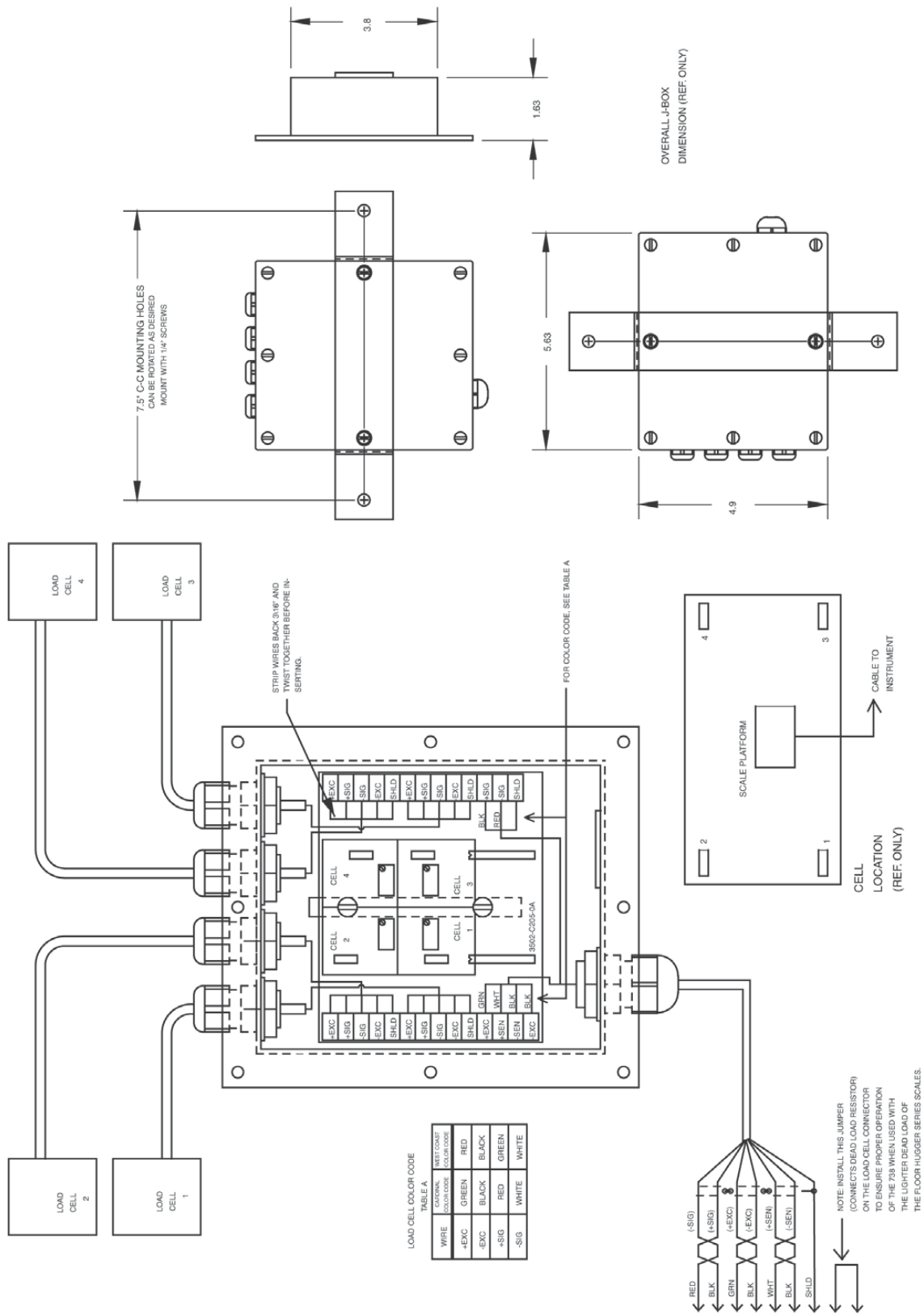

Figure No. 4

STATEMENT OF LIMITED WARRANTY

WARRANTY TERMS

Cardinal Scale Manufacturing Company warrants the equipment we manufacture against defects in material and workmanship. The length and terms and conditions of these warranties vary with the type of product and are summarized below:

PRODUCT TYPE	TERM	MATERIAL AND WORKMANSHIP	LIGHTNING DAMAGE See note 9	WATER DAMAGE See note 7	CORROSION See note 4	ON-SITE LABOR	LIMITATIONS AND REQUIREMENTS
WEIGHT INDICATORS	90 DAY REPLACEMENT ----- 1 YEAR PARTS	YES	YES	YES	YES	NO	1, 2, 3, 5, 6 A, B, C, D
LOAD CELLS (Excluding Hydraulic)	1 YEAR	YES	YES	YES	YES	NO	1, 2, 3, 5, 6 A, B, C, D
HYDRAULIC LOAD CELLS (When purchased with Guardian Vehicle Scale)	LIFETIME	YES	YES	YES	YES	90 DAYS	1, 5, 6, 8 A, B, C, D
HYDRAULIC LOAD CELLS (When purchased separately)	10 YEARS	YES	YES	YES	YES	NO	1, 5, 6, 8, 9 A, B, C, D
VEHICLE SCALE (Deck and Below Excl. PSC Series)	5 YEARS	YES	YES	YES	YES	90 DAYS	1, 2, 3, 5, 6 A, B, C, D, E
LSC SCALE (Deck and Below)	3 YEARS	YES	YES	YES	YES	90 DAYS	1, 2, 3, 5, 6, 11 A, B, C, D
GUARDIAN FLOOR SCALES	10 YEARS	YES	YES	YES	YES	NO	1, 2, 3, 5, 6, 9, 10 A, B, C, D
ALL OTHER CARDINAL PRODUCTS	1 YEAR	YES	YES	YES	YES	NO	1, 2, 5, 6 A, B, C, D, E
REPLACEMENT PARTS	90 DAYS	YES	YES	YES	YES	NO	1, 2, 4, 5, 6 A, B, C, D
SWIM AND 760 SERIES VEHICLE SCALES	1 YEAR	YES	YES	YES	YES	90 DAYS	1, 2, 5, 6 A, B, C, D
SOFTWARE	90 DAYS	YES	N/A	N/A	N/A	NO	1, 6 B, C, D
CONVEYOR BELT SCALES (including Belt-Way)	1 YEAR	YES	YES	YES	YES	NO	1, 2, 3, 5, 6 A, B, C, D, E, F



CARDINAL

Ph. (800) 441-4237
E-mail: cardinal@cardet.com
102 E. Daugherty
Webb City, MO 64870

04/24
Printed in USA
315-WARRANTY-CAR-M

APPLICABLE LIMITATIONS AND REQUIREMENTS

1. This warranty applies only to the original purchaser. The warranty does not apply to equipment that has been tampered with, defaced, damaged, or had repairs or modifications not authorized by Cardinal or has had the serial number altered, defaced or removed.
2. This warranty is not applicable to equipment that has not been grounded in accordance with Cardinal's recommendations.
3. This equipment must be installed and continuously maintained by an authorized Cardinal / Belt-Way dealer.
4. Applies only to components constructed from stainless steel.
5. This warranty does not apply to equipment damaged in transit. Claims for such damage must be made with the responsible freight carrier in accordance with freight carrier regulations.
6. Warranty term begins with date of shipment from Cardinal.
7. Only if device is rated NEMA 4 or better or IP equivalent.
8. Lifetime warranty applies to damages resulting from water, lightning, and voltage transients and applies only to the hydraulic load cell structure itself (does not include pressure transducers, rubber seals, o-rings, and associated wiring).
9. 10-Year prorated warranty on hydraulic load cells.
10. 1-Year warranty for scale structure.
11. PSC models' warranty coverage applies only to agricultural installations on farms up to 3,000 acres (LSC models not limited in this manner).
12. Load cell kits MUST be installed in accordance with Cardinal Scale instructions. Failure to follow these instructions will void the warranty.

EXCLUSIONS

- A.) This warranty does not include replacement of consumable or expendable parts. The warranty does not apply to any item that has been damaged due to unusual wear, abuse, improper line voltage, overloading, theft, fire, water, prolonged storage or exposure while in purchaser's possession or acts of God unless otherwise stated herein.
- B.) This warranty does not apply to peripheral equipment not manufactured by Cardinal. This equipment will normally be covered by the equipment manufacturer's warranty.
- C.) This warranty sets forth the extent of our liability for breach of any warranty or deficiency in connection with the sale or use of our product. Cardinal will not be liable for consequential damages of any nature, including but not limited to loss of profit, delays or expenses, whether based on tort or contract. Cardinal reserves the right to incorporate improvements in material and design without notice and is not obligated to incorporate said improvements in equipment previously manufactured.
- D.) This warranty is in lieu of all other warranties expressed or implied including any warranty that extends beyond the description of the product including any warranty of merchantability or fitness for a particular purpose. This warranty covers only those Cardinal products installed in the forty-eight contiguous United States and Canada.
- E.) This warranty does not cover paint coatings due to the variety of environmental conditions.
- F.) Do not cut load cell cables on load cells returned for credit or warranty replacement. Cutting the cable will void the warranty.
- G.) Software is warranted only for performance of the functions listed in the software manual and/or the Cardinal proposal.
- H.) The software warranty does not cover hardware. Warranties on hardware are provided from the hardware vendor only.
- I.) The software warranty does not cover interfacing issues to non-Cardinal supplied hardware.
- J.) The software warranty does not include automatic software upgrades unless purchased separately.



Ph. (800) 441-4237
E-mail: cardinal@cardet.com
102 E. Daugherty
Webb City, MO 64870

04/24
Printed in USA
315-WARRANTY-CAR-M

Printed in USA

1905-M142-O1 Rev D 05/01

Cardinal Scale Mfg. Co.

102 E. Daugherty, Webb City, MO 64870 USA

Ph: 417-673-4631 or 1-800-641-2008

Fax: 417-673-2153

www.cardinalscale.com

Technical Support: 1-866-254-8261

E-mail: tech@cardet.com