



CARDINAL®



SLS Series

Single Animal Livestock Scale

Owner's Manual

TABLE OF CONTENTS

INTRODUCTION - - - - -	1
Overview - - - - -	1
Features - - - - -	2
Options - - - - -	2
SPECIFICATIONS - - - - -	3
Livestock Pen and Gate Models - - - - -	4
Deck Only Models - - - - -	4
SAFETY - - - - -	5
Safety Symbol Definitions - - - - -	5
GENERAL SAFETY - - - - -	5
ANIMAL SAFETY - - - - -	6
LIFTING AND UNLOADING THE SCALE - - - - -	7
Lift the Scale - - - - -	7
INSTALLATION - - - - -	8
Removing the Shipping Brackets - - - - -	8
Adjust the Support Feet - - - - -	8
OPERATION - - - - -	9
Gate Operation - - - - -	9
Securing the Gate Before Weighing the Animal - - - - -	9
TROUBLESHOOTING - - - - -	10
CALIBRATION PROCEDURE - - - - -	11
TRIM ADJUSTMENT - - - - -	12
Single Load Cell - - - - -	12
Two or More Load Cells - - - - -	13
SCALE INTERCONNECTION DIAGRAM - - - - -	14
PARTS IDENTIFICATION - - - - -	15
Livestock Pen and Gate Models - - - - -	15
Deck Only Models - - - - -	18

COPYRIGHT

All rights reserved. Reproduction or use, without express written permission, of editorial or pictorial content, in any manner, is prohibited. No patent liability is assumed with respect to the use of the information contained herein.

DISCLAIMER

While every precaution has been taken in the preparation of this manual, the Seller assumes no responsibility for errors or omissions. Neither is any liability assumed for damages resulting from the use of the information contained herein. All instructions and diagrams have been checked for accuracy and ease of application; however, success and safety in working with tools depend largely upon individual accuracy, skill, and caution. For this reason, the Seller is not able to guarantee the result of any procedure contained herein. Nor can they assume responsibility for any damage to property or injury to persons occasioned from the procedures. Persons engaging in the procedures do so entirely at their own risk.

FCC COMPLIANCE STATEMENT

This equipment generates uses, can radiate radio frequency, and if not installed and used in accordance with the instruction manual, may cause interference to radio communications. It has been designed within the limits for a Class A computing device pursuant to Subpart J of Part 15 of FCC rules to provide reasonable protection against such interference when operated in a commercial environment. Operation of this equipment in a residential area may cause interference in which case the user will be responsible for taking whatever measures necessary to correct the interference.

You may find the booklet "How to Identify and Resolve Radio-TV Interference Problems" prepared by the Federal Communications Commission helpful. It is available from the U.S. Government Printing Office, Washington, D.C. 20402. Request stock No. 001-000-00315-4.

Serial Number _____
Date of Purchase _____
Purchased Form _____

RETAIN THIS INFORMATION FOR FUTURE USE

<h2>PRECAUTIONS</h2> <p>Before using this scale, read this manual and pay special attention to all "NOTIFICATION" symbols:</p> <p>DANGER! WARNING! CAUTION!</p> 
--

INTRODUCTION

Thank you for selecting and purchasing Cardinal Scale's SLS Series Single Animal Livestock Scale. Your scale was built with quality and reliability and incorporates the latest technology and innovative features for the weighing industry to meet your weighing needs for years to come.

The purpose of this manual is to provide you with a guide through the operation of your SLS series single animal livestock scale. Please read it thoroughly before attempting to use your scale and keep it available for future reference.

Overview

Cardinal Scale's SLS series is an NTEP-certified steel deck single animal livestock scale offering extreme durability and high-quality construction for weighing cattle, swine, horses, sheep, goats, and more. With its adjustable support feet, the SLS can be used on any relatively flat and firm surface. The unique easy-close slide-track gates increase efficiency for the operator and secures the livestock inside the pen while weighing. The SLS series is available in varying widths and lengths, both with and without the livestock pen, and is extremely accurate up to 2,500 lb x 0.5 lb or 5,000 lb x 1 lb capacities.



INTRODUCTION, CONT.

Features

- Accurate to Within 1/2 LB
- Agricultural Products
- Available With or Without Livestock Pen and Dual Slide-Out Gates
- Heavy-Duty 5/8-Inch-Thick Rubber Mat Included
- Mild Steel Construction
- NTEP Legal for Trade
- Stainless Steel Load Cells
- Up to 5000 LB Capacity
- Varying Widths and Lengths Available

Options

- Box Panel Kits
- Remote Displays
- Ticket Printers
- Wi-Fi Connectivity
- Mobile Apps
- Weight Indicators*

* Multiple Cardinal Scale weight indicators can be used with the SLS series scale. For example, the 190, 205, and 212GX. These indicators are all NTEP approved and feature StableSENSE[®] digital filtering that filters out motion on the scale due to animal movement. This digital filtering provides a stable weight display making weighing easier and quicker for the operator.

SPECIFICATIONS

Construction:	Mild steel 1.5-inch-square tubing all welded cage with rugged checkered steel kick panel interior
Gates:	<ul style="list-style-type: none"> • Dual slide-out gates with a large exterior grab handle allow easy loading and unloading • Exterior rotating latch inaccessible to livestock for safety
Paint:	Anti-corrosion, baked-on polyester tan powder paint
Load Cells:	Four model TB 2,500 lb stainless steel specialty shear beam load cells with adjustable support feet
Capacities/Divisions:	Available in either 2,500 x 0.5 lb or 5,000 lb x 1 lb (dual range option also available)
NTEP Certificate of Conformance:	Certificate number 13-083 (legal for trade)
Accuracy Class:	III
Platform Sizes:	30 x 96 in, 36 x 96 in, 36 x 120 in, 48 x 96 in, and 48 x 120 in
Platform Material:	Steel with rubberized non-skid mat
Mat Thickness:	5/8-inch thick high-quality heavy-duty rubber mat for sure footing and noise reduction when weighing (included)
Deck Height:	5-inch step height for easy step-in and exit
Junction Box:	<ul style="list-style-type: none"> • Easy access stainless steel junction box where the load cell wiring merges and connects to the indicator • Stainless steel flex conduit to protect the load cell wiring
Country of Origin:	USA

SPECIFICATIONS, CONT.

Livestock Pen and Gate Models



MODELS	Capacity / Division	Width	Length
2.53096-SLS	2,500 lb x 0.5 lb	30 in	96 in
2.53696-SLS	2,500 lb x 0.5 lb	36 in	96 in
2.536120-SLS	2,500 lb x 0.5 lb	36 in	120 in
2.54896-SLS	2,500 lb x 0.5 lb	48 in	96 in
2.548120-SLS	2,500 lb x 0.5 lb	48 in	120 in

53096-SLS	5,000 lb x 1 lb	30 in	96 in
53696-SLS	5,000 lb x 1 lb	36 in	96 in
536120-SLS	5,000 lb x 1 lb	36 in	120 in
54896-SLS	5,000 lb x 1 lb	48 in	96 in
548120-SLS	5,000 lb x 1 lb	48 in	120 in

Deck Only Models



MODELS	Capacity / Division	Width	Length
2.53096-SLS-D	2,500 lb x 0.5 lb	30 in	96 in
2.53696-SLS-D	2,500 lb x 0.5 lb	36 in	96 in
2.536120-SLS-D	2,500 lb x 0.5 lb	36 in	120 in
2.54896-SLS-D	2,500 lb x 0.5 lb	48 in	96 in
2.548120-SLS-D	2,500 lb x 0.5 lb	48 in	120 in

53096-SLS-D	5,000 lb x 1 lb	30 in	96 in
53696-SLS-D	5,000 lb x 1 lb	36 in	96 in
536120-SLS-D	5,000 lb x 1 lb	36 in	120 in
54896-SLS-D	5,000 lb x 1 lb	48 in	96 in
548120-SLS-D	5,000 lb x 1 lb	48 in	120 in

SAFETY

Safety Symbol Definitions



DANGER! Indicates an imminently hazardous situation that, if not avoided, will result in death or severe injury.



WARNING! Indicates a potentially hazardous situation that, if not avoided could result in severe injury or death.



CAUTION! Indicates a potentially hazardous situation that, if not avoided, may result in minor or moderate injury.

IMPORTANT! Indicates information about procedures that, if not observed, could result in damage to equipment.

GENERAL SAFETY

Do not operate or work on this equipment unless you have read and understood the instructions and warnings in this manual. Failure to follow the instructions or observe the warnings could result in injury or death. Contact Cardinal Scale Tech Support for replacement manuals. Proper care is your responsibility.



WARNING! Failure to follow instructions or observe warnings may result in severe injury or death.

- Do not allow children or inexperienced persons to operate this scale.
- Do not use it for purposes other than weighing.
- Do not place fingers into slots or possible pinch points.
- Do not place hands, feet, or any body part underneath the scale at any time. The scale could be lowered, crushing body parts.
- Do not use this product if any of the components are cracked.
- Do not exceed the rated load limit of the unit.
- Do not make alterations or modifications to the unit.
- Do not remove or obscure warning labels.
- Keep hands, feet, and loose clothing away from moving parts.
- Always be certain when lowering the scale, that everyone is clear of scale.
- Be sure the gates are latched before transporting the scale.
- The weighing platform **must be empty** when the scale is being transported.

ANIMAL SAFETY



WARNING! The Cardinal SLS Single Animal Livestock Scale is not intended for the transportation of animals or storage of any goods. The weighing platform must be empty when the scale is transported. Failure to observe this warning may result in severe injury and/or premature component failure and will void the warranty!



Animal safety is a serious issue and must be observed when handling any type of animal. The scale surface may become slippery during use; a build-up of manure on the scale may reduce traction. It is recommended that you take any necessary precautions to maintain an acceptable level of animal footing.

LIFTING AND UNLOADING THE SCALE

The Cardinal SLS single animal livestock scale can be lifted and transported to any firm surface that is relatively smooth and flat using a forklift.



WARNING! Make sure the forklift forks are long enough to go all the way through under the scale so that the scale rests securely on the forks.



Evenly space forks under scale to maintain balance.



Ensure the forks are completely under the scale.



Carefully lift the scale and proceed to the new location.



IMPORTANT! Make sure both scale gates are closed and both latches are in the locked position when lifting, loading, and transporting the scale.

Gate latch shown in “locked” position.



Lift the Scale

1. Adjust the forks of the forklift to make sure each fork is the same distance from the center of the scale so the scale stays balanced.
2. Carefully approach the scale inserting the forks under the scale.
3. Ensure the forks are fully positioned under the scale before attempting to lift.
4. Carefully lift the scale and proceed to the selected location for the operation. Note that the scale can be used on any firm surface that is relatively smooth and flat.
5. When not using the scale, it should be stored on the same type of surface.



DANGER! The SLS scale is very heavy. Make sure the forks on the forklift used for lifting the scale are adequate and that the scale is resting on them securely before transporting the scale.

Make sure that everyone is clear of the scale (not under, on, or around the scale) when lifting and transporting the scale to the selected location.

INSTALLATION

The following section outlines procedures for installing your scale.

1. Choose a location for the scale that is a firm surface, relatively smooth, flat, and free of debris.
2. Do not push or slide the scale once it is on the ground, damage to the load cells may result.
3. With the scale in its selected location, remove the shipping brackets before lowering the scale completely to the ground. Once the scale is on the ground, adjust the feet to evenly support the scale, and make certain the weight is evenly distributed over the four corners of the scale.
4. Remove the weight indicator from the packing box and connect the cable from the scale to the weight indicator, following the instructions provided in the weight indicator manual.
5. After the connection has been made, power up and zero the weight indicator according to the weight indicator manual directions.

Removing the Shipping Brackets

Before placing the scale in its selected location, the shipping brackets must be removed.

1. At the selected location for the scale, lower it to approximately 6-8 inches above the ground.
2. Remove the four 1/4-20 hex head screws (two on the side and two on the end) securing the shipping bracket to the scale base.
3. Repeat step 2 for each shipping bracket.
4. After the four shipping brackets have been removed, the scale can be lowered to the ground.
5. Once the scale is on the ground, proceed with adjusting the support feet.

Adjust the Support Feet

The load cells used on the SLS scale have adjustable support feet to ensure the scale is evenly supported on the ground. The scale must be evenly supported to prevent it from rocking once the weighing operation has begun. If the scale is rocking during the weighing operation, the indicator will be unable to repeat the weight readings and will show unstable weight.

Once you have positioned the scale in its selected location, check to make sure the scale is not rocking. If necessary, adjust the support feet to ensure the scale is evenly supported on the ground (not rocking) and to make certain the weight is evenly distributed over each of the four corners of the scale.



Remove the four 1/4-20 hex head screws (two on side and two on end) to remove the shipping bracket.



If necessary, adjust the support feet to ensure the scale is evenly supported on the ground and that the weight is evenly distributed over each corner of the scale.

OPERATION

Gate Operation

The gates on the SLS can easily be opened and closed with one hand. Simply grab the large, ergonomic handle and slide the gate open to allow the animal in and out of the scale pen. Closing the gate after the animal is in the scale pen is just as easy requiring only one hand to close it.



The gate can easily be opened and closed with one hand.



The gate is fully opened and ready for the animal to enter or exit the scale pen.

Securing the Gate Before Weighing the Animal

Once the animal is in the scale pen, close the gate and secure the animal in the scale pen by rotating the gate latch located on the exterior of the pen.

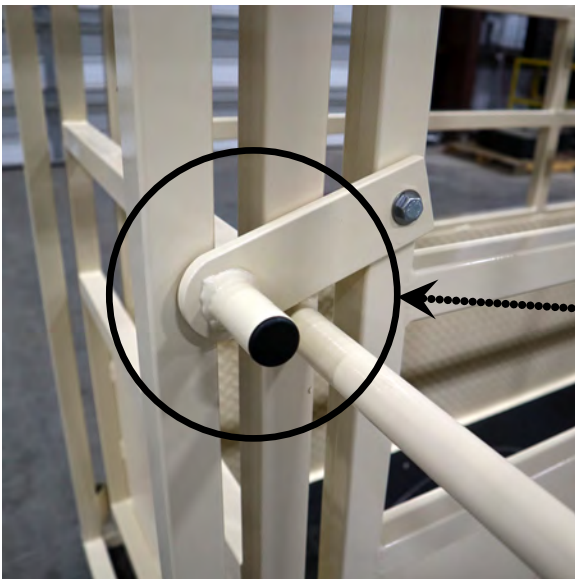

Latch rotated to closed position.



Both gates closed and latched.

TROUBLESHOOTING

If a difficulty is encountered with the operation of the scale a visual check of the scale platform should be made to make certain operation is not restricted by foreign material, such as rocks, branches, and other debris.

The following troubleshooting guide should prove useful in isolating and correcting a problem with the scale. If the problem cannot be resolved with the use of this troubleshooting guide, contact a qualified scale technician for service.

PROBLEM:

The scale reads accurate weight to a point but will not register beyond that point.

CAUSE:

Obstruction between the ground and the bottom of the scale.

SOLUTION:

Check for and remove the obstruction (rocks, branches, or other debris) from under scale.

PROBLEM:

Cannot obtain repeatable readings or weight indicator shows unstable.

CAUSE:

- A. Scale is not stable. This is usually due to scale rocking from uneven support feet.
- B. Bad or improper wiring
- C. Bad load cell
- D. Bad trim circuit board

SOLUTION:

- A. Adjust support feet until the scale is stable and not rocking.
- B. Check wiring & solder connections
- C. Replace load cell
- D. Replace trim circuit board

CALIBRATION PROCEDURE

Your scale was calibrated at the factory. Minor changes in calibration due to shock and vibration encountered during the transportation of the scale may necessitate re-calibration.



IMPORTANT! The following procedures require a known accurate test weight.

Place a test weight or weights equal to 10 percent of the scale's capacity on the scale platform. Record the weight displayed. If the displayed weight does not fall within $\pm .1\%$ percent of the value of the test weight, the scale may need to be re-calibrated.

Please check the following before proceeding:

- Make certain proper installation procedures were followed.
- Is there anything near or under the scale (such as rocks, branches, or other debris) restricting proper scale operation?



IMPORTANT! It is recommended the calibration procedures be performed by a qualified scale technician.

1. Place a test weight equal to 10 percent of the scale's capacity over each of the four load cells (the corner of the scale), one at a time.
2. Record the displayed weight of each corner.
3. If the difference in displayed weight exceeds $\pm .1$ percent of the test weight, trimming adjustments for your load cells must be performed. Refer to the next section, TRIM ADJUSTMENT for further instruction.
4. If all four weight readings are within the allowable tolerance ($\pm .1$ percent of the test weight), the weight indicator should be re-calibrated per the instructions in the weight indicator manual.



Reference Handbook #44, Table 6, for Accuracy Tolerance.

TRIM ADJUSTMENT

The purpose of adjusting trim is so the same weight reading will be displayed regardless of where the load is placed on the scale deck. All scales are corner trimmed before leaving the factory. In the event of re-calibration or load cell replacement, follow the instructions below to re-trim the corners. It is assumed the other three load cells are already corner-sealed to agree with each other. If not, please refer to the next page for further instructions.

Single Load Cell

1. Remove the junction box cover access plate located on the side of the scale.
2. Remove the junction box access cover.
3. Refer to the figure below for load cell location reference.
4. Turn the trim potentiometer for the load cell needing re-calibration clockwise for 25 turns, or until a click is heard indicating the end of the potentiometer adjustment.
5. Place a test weight on each corner, one at a time, and record the displayed weight for each corner.
6. Place a test weight on the corner with the highest reading and adjust the appropriate trim potentiometer until the weight reading agrees with the lowest reading obtained in Step 5.
7. Repeat Step 6 until all corners have the same weight reading.
8. Replace the screws securing the junction box cover and access plate.

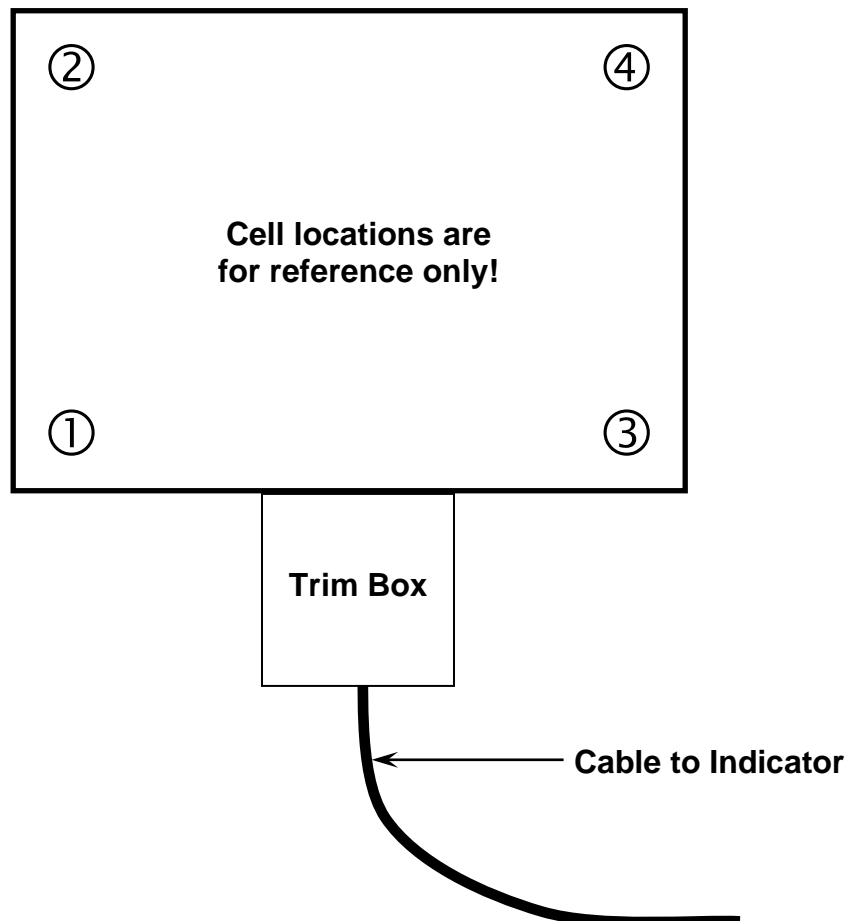

TRIM ADJUSTMENT CONT.

Two or More Load Cells

If two or more load cells must be replaced or the scale needs an overall resealing of each corner, these procedures should be followed.

1. Remove the junction box access plate located on the side of the scale. Remove the junction box access cover.
2. Turn all potentiometers clockwise 25 turns or until a click is heard. Now turn all potentiometers counterclockwise 1 (one) turn.
3. Place a test weight of at least 10 percent of the scale's capacity on each corner, one at a time, and record each displayed weight.
4. Place a test weight on the corner with the highest displayed weight and adjust the appropriate trim potentiometer counterclockwise until the corner reading agrees with the lowest weight reading.
5. Repeat Step No. 4 until all corners are equal.
6. Re-calibrate the weight indicator following the procedures in the indicator manual.
7. Replace the screws securing the junction box cover and access plate.

EXAMPLE

	CORNER #			
1000# TEST WEIGHT	1	2	3	4
DISPLAYED WEIGHT READING	1020	1016	1017	1021

1. Place a test weight on each corner, one at a time, and record each displayed weight.
2. Place a test weight on corner no. 1 and adjust the no. 1 trim potentiometer to reduce the displayed weight to the lowest corner reading (No. 2 in the example).
3. Repeat step 2 with corner no. 3 and 4 until all corners are the same.
4. Calibrate the weight indicator following the instructions provided in the indicator manual.

SCALE INTERCONNECTION DIAGRAM

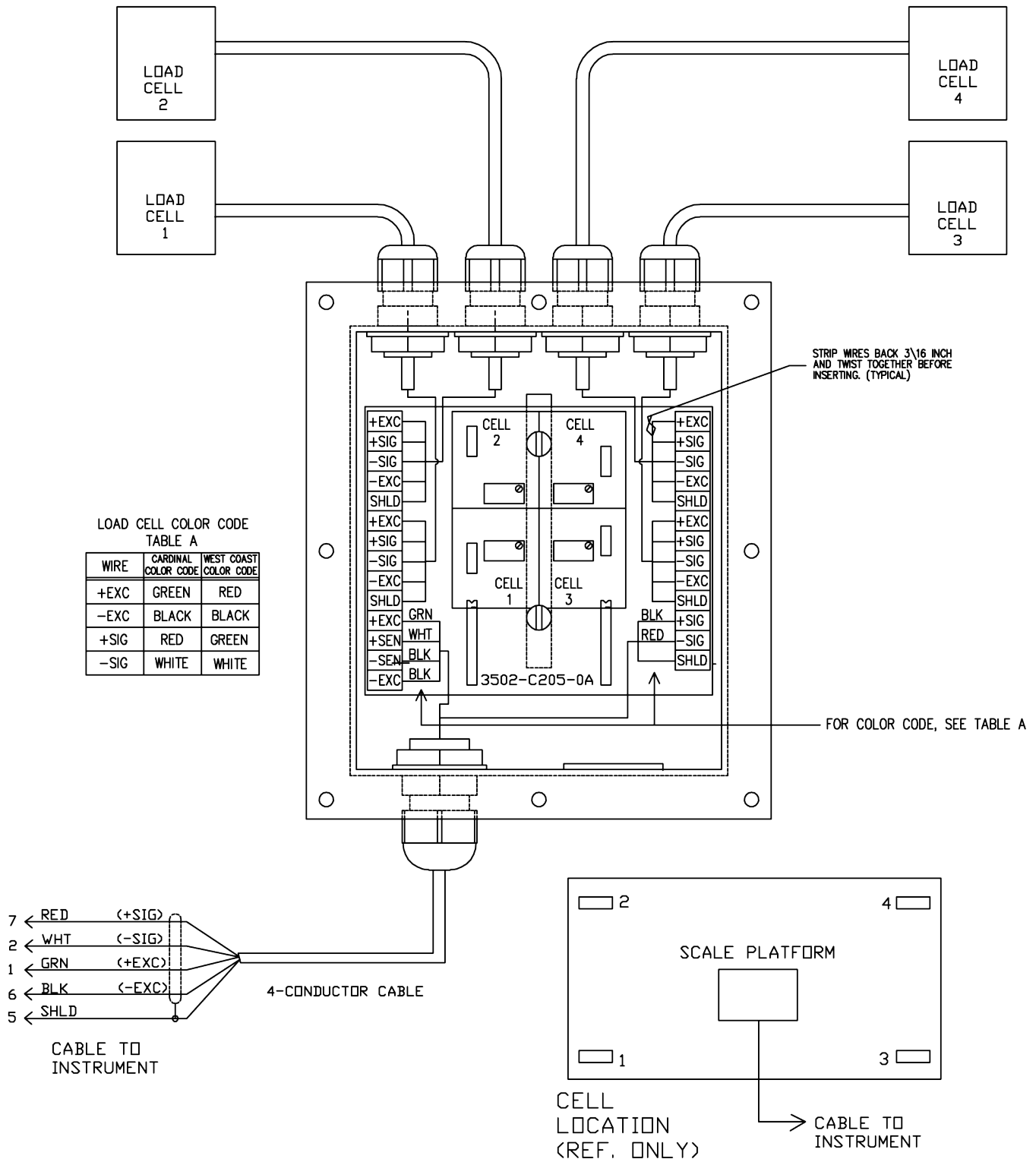

PARTS IDENTIFICATION

Livestock Pen and Gate Models

ITEM	QTY	PART NUMBER	DESCRIPTION
1	1	1913-0315-0A	BASE ASSY. FOR 2.53096-SLS / 53096-SLS
	1	1913-0282-0A	BASE ASSY. FOR 2.53696-SLS / 53696-SLS
	1	1913-0443-0A	BASE ASSY. FOR 2.536120-SLS / 536120-SLS
	1	1913-0331-0A	BASE ASSY. FOR 2.54896-SLS / 54896-SLS
	1	1913-0357-0A	BASE ASSY. FOR 2.548120-SLS / 548120-SLS
2	1	1913-0314-0A	SIDE PANEL ASSY. FOR 2.53096-SLS / 53096-SLS
	1	1913-0262-0A	SIDE PANEL ASSY. FOR 2.53696-SLS / 53696-SLS
	1	1913-0445-0A	SIDE PANEL ASSY. FOR 2.536120-SLS / 536120-SLS
	1	1913-0330-0A	SIDE PANEL ASSY. FOR 2.54896-SLS / 54896-SLS
	1	1913-0354-0A	SIDE PANEL ASSY. FOR 2.548120-SLS / 548120-SLS
3	14	6007-0052	BLT HEX HEAD, 3/8-16 x 2 1/2" ZP
4	34	6024-0009	WASHER FLAT, 3/8" ZP
5	1	1913-0313-0A	GATE ASSY. FOR 2.53096-SLS / 53096-SLS
	1	1913-0258-0A	GATE ASSY. FOR 2.53696-SLS, 53696-SLS, 2.536120-SLS, and 536120-SLS
	1	1913-0329-0A	GATE ASSY. FOR 2.54896-SLS, 54896-SLS, 2.548120-SLS, and 548120-SLS
6	1	0145-B393-08	DECAL – DO NOT WELD
7	2	6007-0054	SCW HEX HEAD, 3/8-16 x 2 1/4" ZP
8	8	6021-1239	SCW SHOULDER, 3/8 x 2 1/4" x 5/16-18 Z/P
9	8	6013-0410	NUT ELASTIC STOP, 5/16-18 Z/P
10	16	6013-0070	NUT ELASTIC STOP, 3/8-16 Z/P
11	1	3502-C208-2A	JUNCTION BOX, 2-4 LOAD CELLS, S.S., w/MOUNTING
12	8	6540-1166	WHEEL, 3" DIA x 1 1/4 WIDE 5/16 HOLE
13	2	6980-1067	CONN. CONDUIT
14	1	3502-B397-0A	LOAD CELL CBL 30 FT. 3-PAIR
15	1	1913-0313-1A	GATE ASSY. FOR 2.53096-SLS / 53096-SLS
	1	1913-0258-1A	GATE ASSY. FOR 2.53696-SLS, 53696-SLS, 2.536120-SLS, and 536120-SLS
	1	1913-0329-1A	GATE ASSY. FOR 2.54896-SLS, 54896-SLS, 2.548120-SLS, and 548120-SLS

PARTS IDENTIFICATION, CONT.

Livestock Pen and Gate Models, Cont.

ITEM	QTY	PART NUMBER	DESCRIPTION
16	1	1913-0247-08	MAT FOR 2.53096-SLS / 53096-SLS
	1	1913-B218-08	MAT FOR 2.53696-SLS / 53696-SLS
	1	1913-0447-08	MAT FOR 2.536120-SLS / 536120-SLS
	1	1913-0328-08	MAT FOR 2.54896-SLS / 54896-SLS
	1	1913-0353-08	MAT FOR 2.548120-SLS / 548120-SLS
17	1	1913-B216-08	CONDUIT HOLDER
18	2ft	6710-0041	CONDUIT
19	REF	190	REFERENCE INDICATOR
20	2	1913-0267-0A	LATCH ASSY.
21	6	6021-1416	SCW HEX/WASHER SHEET-METAL #12X.750
22	1	593M729	SERIAL TAG
23	4	6680-0214	POP RIVET
24	2	5930-0158-08	LABEL, CARDINAL LOGO
26	4	1913-0274-08	SHIPPING BRACKET
27	16	6021-0014	SCW HEX/WASHER/SLOTTED, 1/4-20 x 5/8", TYPE F, Z/P
28	1	1913-0367-08	RAIN HOOD
29	4	TB-2.5KMP	LOAD CELL, BEAM, 2,500 LB, STAINLESS STEEL
30	8	6007-2200	BLT HEX HD, M12 x 1.25 x 45mm, GRADE 8.8 Z/P
31	4	1913-B039-08	LOAD CELL SPACER, SS, TB-XXKMP
32	4	1913-B040-0A	FOOT ASSY.
33	8	6013-0084	NUT, M12 x 1.75, HEX NARROW, JAM, ZP

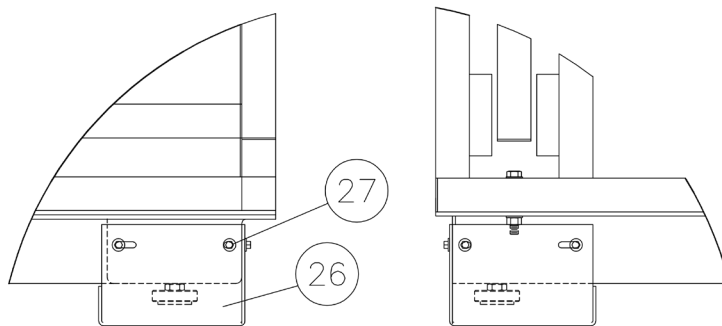

SHIPPING BRACKET DETAIL

ATTACH ITEM 26 WITH ITEM 27 ON ALL 4 CORNERS
REMOVE SHIPPING BRACKETS BEFORE INSTALLING SCALE

PARTS IDENTIFICATION, CONT.

Livestock Pen and Gate Models, Cont.

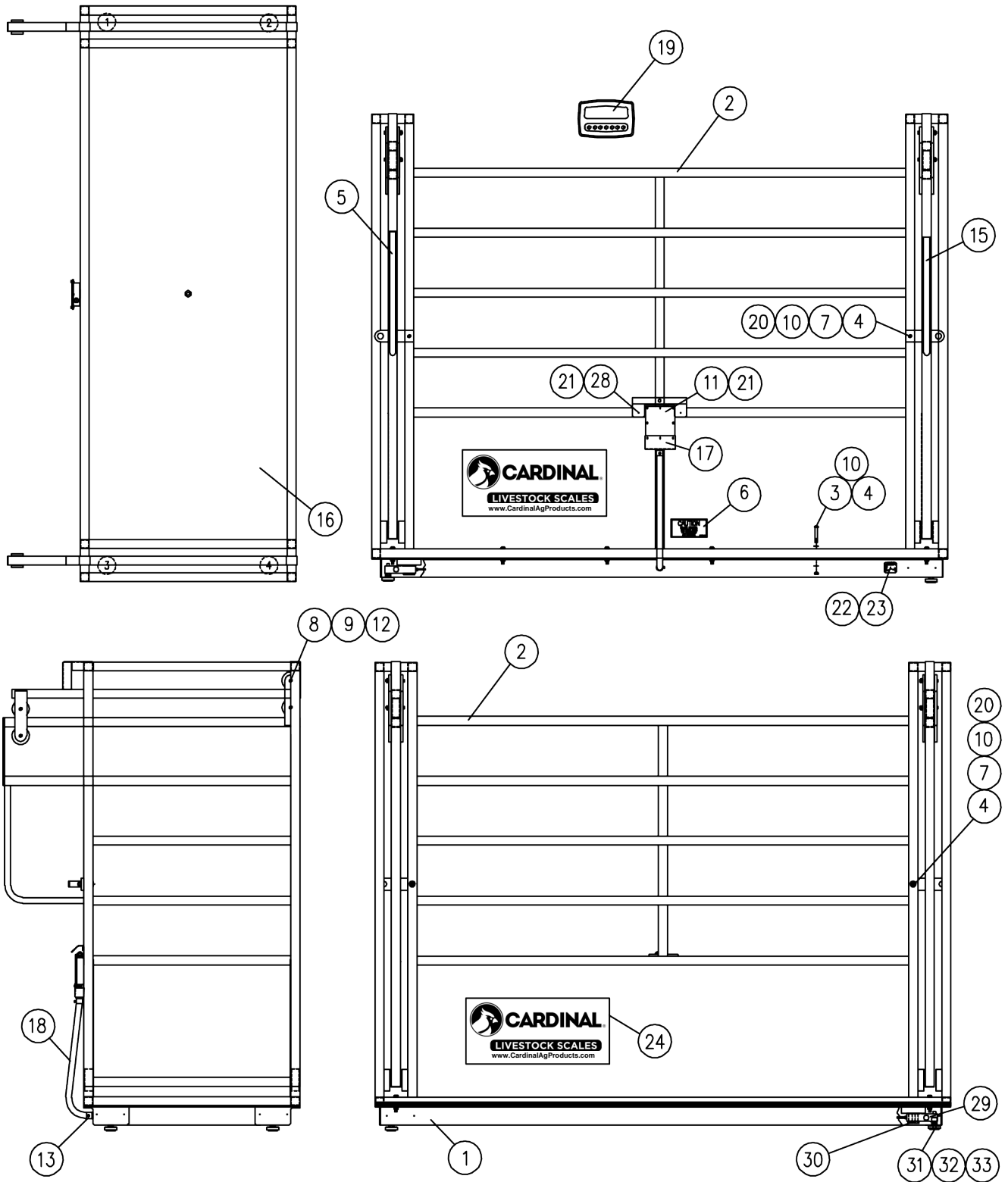

PARTS IDENTIFICATION, CONT.

Deck Only Models

ITEM	QTY	PART NUMBER	DESCRIPTION
1	1	1913-0316-0A	WEIGHBRIDGE FOR 2.53096-SLS-D / 53096-SLS-D
	1	1913-0244-0A	WEIGHBRIDGE FOR 2.53696-SLS-D / 53696-SLS-D
	1	1913-0444-0A	WEIGHBRIDGE FOR 2.536120-SLS-D / 536120-SLS-D
	1	1913-0332-0A	WEIGHBRIDGE FOR 2.54896-SLS-D / 54896-SLS-D
	1	1913-0358-0A	WEIGHBRIDGE FOR 2.548120-SLS-D / 548120-SLS-D
2	4	TB-2.5KMP	LOAD CELL, BEAM, 2,500 LB, STAINLESS STEEL
3	8	6007-2200	BLT HEX HD, M12 x 1.25 x 45mm, GRADE 8.8 Z/P
4	4	1913-B039-08	LOAD CELL SPACER, SS, TB-XXKMP
5	4	1913-B040-0A	FOOT ASSY.
6	8	6013-0084	NUT, M12 x 1.75, HEX NARROW, JAM, ZP
7	REF	190	REFERENCE INDICATOR
8	1	3502-C208-2A	JUNCTION BOX, 2-4 LOAD CELLS, S.S., w/MOUNTING
9	2	6980-1067	CONN. CONDUIT
10	1	6540-1608	MAT FOR 2.53096-SLS-D / 53096-SLS-D
	1	6540-1603	MAT FOR 2.53696-SLS-D / 53696-SLS-D
	1	1913-0496-08	MAT FOR 2.536120-SLS-D / 536120-SLS-D
	1	6540-1623	MAT FOR 2.54896-SLS-D / 54896-SLS-D
	1	6540-1613	MAT FOR 2.548120-SLS-D / 548120-SLS-D
11	1	3502-B397-0A	LOAD CELL CBL 30 FT. 3-PAIR
12	1	1913-B216-08	CONDUIT HOLDER
13	2ft	6710-0041	CONDUIT
14	4	6021-1416	SCW HEX/WASHER SHEET-METAL #12X.750
15	1	593M729	SERIAL TAG
16	4	6680-0214	POP RIVET
17	20	6021-1432	SCW PAN-HEAD, MACHINE-SCW, .25-20 x 1.75
18	20	391RV204	NUT, 1/4-20, ELASTIC STOP, Z/P
19	40	6024-1066	WASHER FLAT, 1/4 x 1 x 1/16, TK, Z-PLATE
20	1	1913-0366-18	MAT CLAMP BAR FOR 2.53096-SLS-D, 53096-SLS-D, 2.53696-SLS-D, and 53696-SLS-D
	1	1913-0448-08	MAT CLAMP BAR FOR 2.536120-SLS-D, 536120-SLS-D, 2.548120-SLS-D, and 548120-SLS-D
	1	1913-0366-08	MAT CLAMP BAR FOR 2.54896-SLS-D / 54896-SLS-D
21	4	1913-0274-08	SHIPPING BRACKET
22	16	6021-0014	SCW HEX/WASHER/SLOTTED, 1/4-20 x 5/8", TYPE F, Z/P

PARTS IDENTIFICATION, CONT.

Deck Only Models

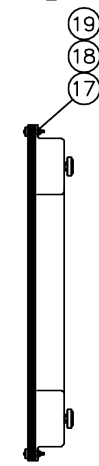
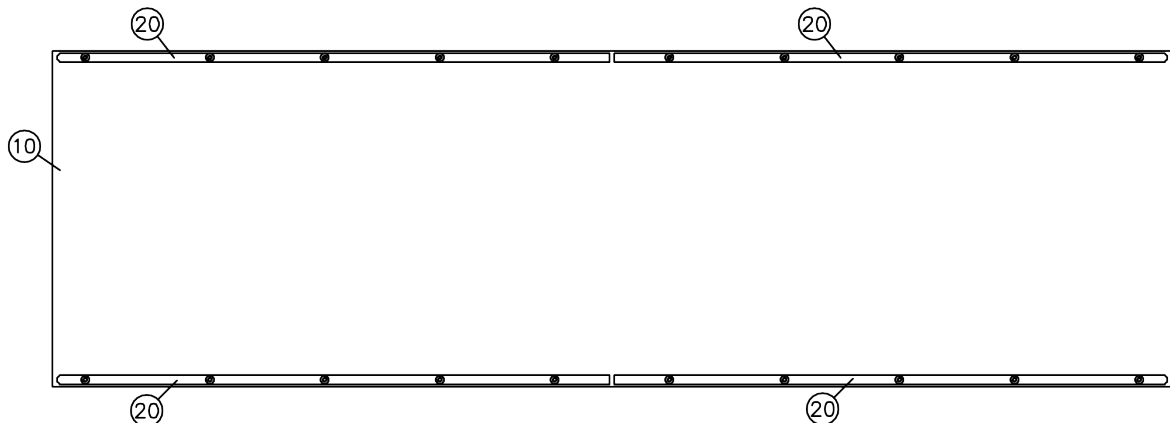
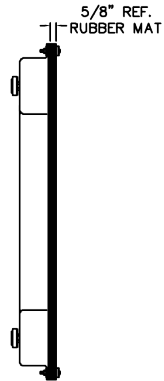
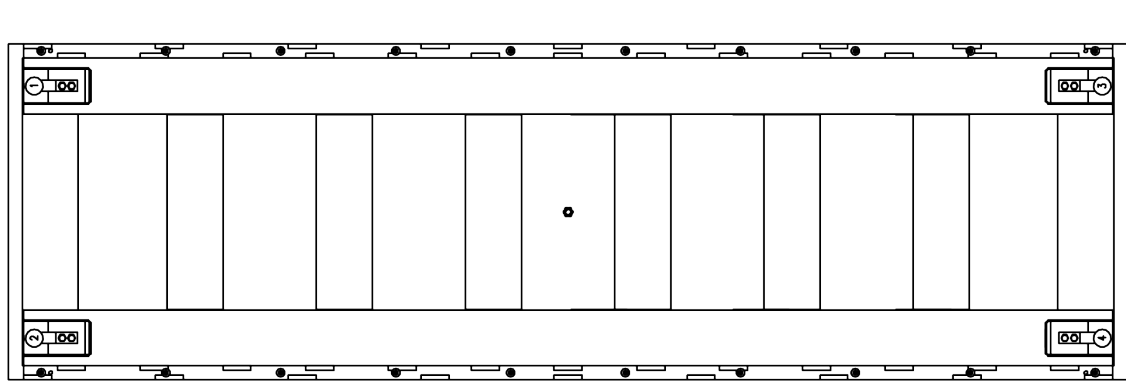
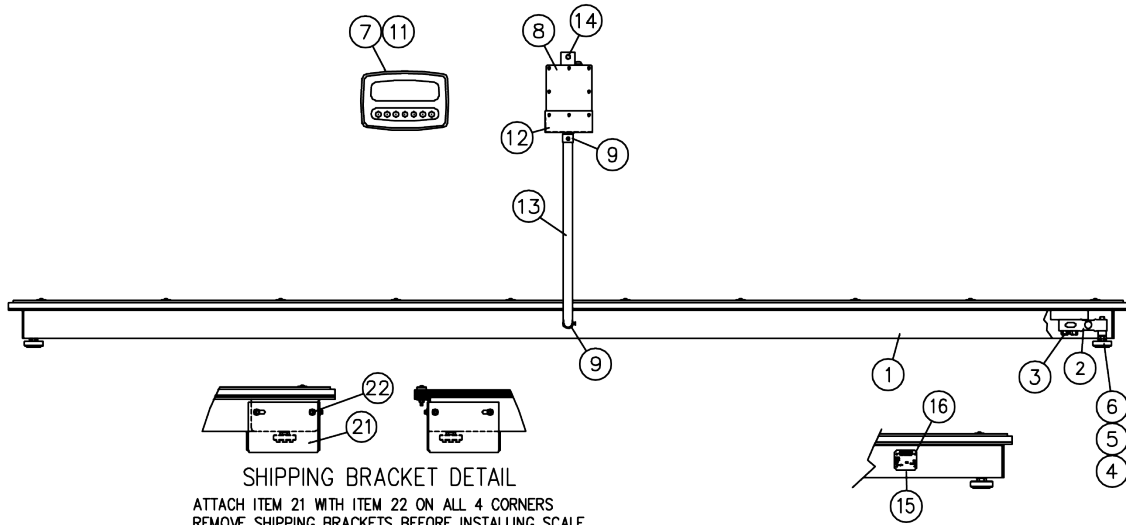

STATEMENT OF LIMITED WARRANTY

WARRANTY TERMS

Cardinal Scale Manufacturing Company warrants the equipment we manufacture against defects in material and workmanship. The length and terms and conditions of these warranties vary with the type of product and are summarized below:

PRODUCT TYPE	TERM	MATERIAL AND WORKMANSHIP	LIGHTNING DAMAGE See note 9	WATER DAMAGE See note 7	CORROSION See note 4	ON-SITE LABOR	LIMITATIONS AND REQUIREMENTS
WEIGHT INDICATORS	90 DAY REPLACEMENT ----- 1 YEAR PARTS	YES	YES	YES	YES	NO	1, 2, 3, 5, 6 A, B, C, D
LOAD CELLS (Excluding Hydraulic)	1 YEAR	YES	YES	YES	YES	NO	1, 2, 3, 5, 6 A, B, C, D
HYDRAULIC LOAD CELLS (When purchased with Guardian Vehicle Scale)	LIFETIME	YES	YES	YES	YES	90 DAYS	1, 5, 6, 8 A, B, C, D
HYDRAULIC LOAD CELLS (When purchased separately)	10 YEARS	YES	YES	YES	YES	NO	1, 5, 6, 8, 9 A, B, C, D
VEHICLE SCALE (Deck and Below Excl. PSC Series)	5 YEARS	YES	YES	YES	YES	90 DAYS	1, 2, 3, 5, 6 A, B, C, D, E
LSC SCALE (Deck and Below)	3 YEARS	YES	YES	YES	YES	90 DAYS	1, 2, 3, 5, 6, 11 A, B, C, D
GUARDIAN FLOOR SCALES	10 YEARS	YES	YES	YES	YES	NO	1, 2, 3, 5, 6, 9, 10 A, B, C, D
ALL OTHER CARDINAL PRODUCTS	1 YEAR	YES	YES	YES	YES	NO	1, 2, 5, 6 A, B, C, D, E
REPLACEMENT PARTS	90 DAYS	YES	YES	YES	YES	NO	1, 2, 4, 5, 6 A, B, C, D
SWIM AND 760 SERIES VEHICLE SCALES	1 YEAR	YES	YES	YES	YES	90 DAYS	1, 2, 5, 6 A, B, C, D
SOFTWARE	90 DAYS	YES	N/A	N/A	N/A	NO	1, 6 B, C, D
CONVEYOR BELT SCALES (including Belt-Way)	1 YEAR	YES	YES	YES	YES	NO	1, 2, 3, 5, 6 A, B, C, D, E, F



CARDINAL

Ph. (800) 441-4237
E-mail: cardinal@cardet.com
102 E. Daugherty
Webb City, MO 64870

04/24
Printed in USA
315-WARRANTY-CAR-M

APPLICABLE LIMITATIONS AND REQUIREMENTS

1. This warranty applies only to the original purchaser. The warranty does not apply to equipment that has been tampered with, defaced, damaged, or had repairs or modifications not authorized by Cardinal or has had the serial number altered, defaced or removed.
2. This warranty is not applicable to equipment that has not been grounded in accordance with Cardinal's recommendations.
3. This equipment must be installed and continuously maintained by an authorized Cardinal / Belt-Way dealer.
4. Applies only to components constructed from stainless steel.
5. This warranty does not apply to equipment damaged in transit. Claims for such damage must be made with the responsible freight carrier in accordance with freight carrier regulations.
6. Warranty term begins with date of shipment from Cardinal.
7. Only if device is rated NEMA 4 or better or IP equivalent.
8. Lifetime warranty applies to damages resulting from water, lightning, and voltage transients and applies only to the hydraulic load cell structure itself (does not include pressure transducers, rubber seals, o-rings, and associated wiring).
9. 10-Year prorated warranty on hydraulic load cells.
10. 1-Year warranty for scale structure.
11. PSC models' warranty coverage applies only to agricultural installations on farms up to 3,000 acres (LSC models not limited in this manner).
12. Load cell kits MUST be installed in accordance with Cardinal Scale instructions. Failure to follow these instructions will void the warranty.

EXCLUSIONS

- A.) This warranty does not include replacement of consumable or expendable parts. The warranty does not apply to any item that has been damaged due to unusual wear, abuse, improper line voltage, overloading, theft, fire, water, prolonged storage or exposure while in purchaser's possession or acts of God unless otherwise stated herein.
- B.) This warranty does not apply to peripheral equipment not manufactured by Cardinal. This equipment will normally be covered by the equipment manufacturer's warranty.
- C.) This warranty sets forth the extent of our liability for breach of any warranty or deficiency in connection with the sale or use of our product. Cardinal will not be liable for consequential damages of any nature, including but not limited to loss of profit, delays or expenses, whether based on tort or contract. Cardinal reserves the right to incorporate improvements in material and design without notice and is not obligated to incorporate said improvements in equipment previously manufactured.
- D.) This warranty is in lieu of all other warranties expressed or implied including any warranty that extends beyond the description of the product including any warranty of merchantability or fitness for a particular purpose. This warranty covers only those Cardinal products installed in the forty-eight contiguous United States and Canada.
- E.) This warranty does not cover paint coatings due to the variety of environmental conditions.
- F.) Do not cut load cell cables on load cells returned for credit or warranty replacement. Cutting the cable will void the warranty.
- G.) Software is warranted only for performance of the functions listed in the software manual and/or the Cardinal proposal.
- H.) The software warranty does not cover hardware. Warranties on hardware are provided from the hardware vendor only.
- I.) The software warranty does not cover interfacing issues to non-Cardinal supplied hardware.
- J.) The software warranty does not include automatic software upgrades unless purchased separately.



Ph. (800) 441-4237
E-mail: cardinal@cardet.com
102 E. Daugherty
Webb City, MO 64870

04/24
Printed in USA
315-WARRANTY-CAR-M

Cardinal Scale Mfg. Co.

102 E. Daugherty, Webb City, MO 64870 USA

Ph: 417-673-4631 or 1-800-641-2008

Fax: 417-673-2153

www.cardinalscale.com

Technical Support: 1-866-254-8261

E-mail: tech@cardet.com

Printed in USA

1913-0609-0M Rev B 01/25