



CARDINAL®



**Admiral Series CA-190
Bench Scale
Owner's Manual**

FCC Compliance Statement

This equipment generates uses, can radiate radio frequency, and if not installed and used in accordance with the instruction manual, may cause interference to radio communications. It has been tested and found to comply with the limits for a Class A computing device pursuant to Subpart J of Part 15 of FCC rules, which are designed to provide reasonable protection against such interference when operated in a commercial environment. Operation of this equipment in a residential area may cause interference in which case the user will be responsible to take whatever measures necessary to correct the interference.

You may find the booklet "How to Identify and Resolve Radio TV Interference Problems" prepared by the Federal Communications Commission helpful. It is available from the U.S. Government Printing Office, Washington, D.C. 20402. Order stock number 001-000-00315-4.

Copyright

All rights reserved. Reproduction or use, without expressed written permission, of editorial or pictorial content, in any manner, is prohibited. No patent liability is assumed with respect to the use of the information contained herein.

Disclaimer

While every precaution has been taken in the preparation of this manual, the Seller assumes no responsibility for errors or omissions. Neither is any liability assumed for damages resulting from use of the information contained herein. All instructions and diagrams have been checked for accuracy and ease of application; however, success and safety in working with tools depend to a great extent upon the individual accuracy, skill and caution. For this reason, the Seller is not able to guarantee the result of any procedure contained herein. Nor can they assume responsibility for any damage to property or injury to persons occasioned from the procedures. Persons engaging the procedures do so entirely at their own risk.

Proper Disposal



When this device reaches the end of its useful life, it must be properly disposed of. It must not be disposed of as unsorted municipal waste. Within the European Union, this device should be returned to the distributor from where it was purchased for proper disposal. This is in accordance with EU Directive 2002/96/EC. Within North America, the device should be disposed of in accordance with the local laws regarding the disposal of waste electrical and electronic equipment.



It is everyone's responsibility to help maintain the environment and to reduce the effects of hazardous substances contained in electrical and electronic equipment on human health. Please do your part by making certain that this device is properly disposed of. The symbol shown to the right indicates that this device must not be disposed of in unsorted municipal waste programs.

Serial Number _____
Date of Purchase _____
Purchased From _____

RETAIN THIS INFORMATION FOR FUTURE USE

PRECAUTIONS	
Before using this scale, read this manual and pay special attention to all "NOTIFICATION" symbols:	
	
IMPORTANT	ELECTRICAL WARNING

INTRODUCTION

The Admiral Series CA-190 Bench Scale is designed for speed and accuracy with an extremely heavy-duty platform that provides a stable base for high-usage food processing applications. Combined with the extreme-duty 190 Storm indicator with both having an IP69K rating, this bench scale is unmatched. In food processing environments where hygiene and cleanliness are required, cleanup can be performed by high pressure, high temperature wash-down procedures with complete confidence against damage to the scale.

This manual is provided to guide you through operation of your new Admiral CA-190 Bench Scale. Please read it thoroughly before using the scale and keep it handy for future reference.

Model Description

CA8-15KGW-190	Bench Scale, Electronic, 8" x 8", 15 Kg Capacity, Stainless Steel, 190 Indicator
CA8-30W-190	Bench Scale, Electronic, 8" x 8", 30 Lb Capacity, Stainless Steel, 190 Indicator
CA12-60KGW-190	Bench Scale, Electronic, 12" x 12", 60 Kg Capacity, Stainless Steel, 190 Indicator
CA12-120W-190	Bench Scale, Electronic, 12" x 12", 120 Lb Capacity, Stainless Steel, 190 Indicator

Specifications

Enclosure Type Indicator: Scale Base:	IP69K-rated polycarbonate Stainless Steel
Operating Temperature:	14 to 104 °F (-10 to +40 °C)
Display:	Six digit, seven segment, 1 in (25 mm) high backlit LCD
Tare Capacity:	Scale capacity
Sample Rate:	1 to 100 samples per second, selectable
Keypad:	Color coded capacitive touch type, 7 keys
Standard I/O:	1 bi-directional RS232
Power Requirements:	100 to 240 VAC (50/60 Hz) at 0.4A Max.
Optional Battery Type (model BP190):	Lithium-Ion Rechargeable
Optional Rechargeable Battery Continuous Operation Run Times:	92 hours with NO backlight 83 hours with BLUE backlight 48 hours with RED backlight or PINK backlight 45 hours with GREEN backlight 41 hours with YELLOW backlight (Battery life will be extended with SLEEP and AUTO-OFF feature enabled)
Optional Battery Charge Time:	6 hours

SITE PREPARATION REQUIREMENTS

The Admiral Series CA-190 Bench Scale is a precision weight-measuring instrument. As with any precision instrument, it requires an acceptable environment to operate at peak performance and reliability. This section is provided to assist you in obtaining such an environment.

Site Requirements

In order to keep cooling requirements to a minimum, the scale should be placed out of direct sunlight and to provide adequate air circulation, keep the area around the scale clear.

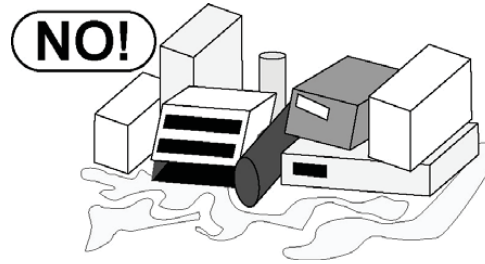

Make certain the scale is not directly in front of a heating or cooling vent. Such a location will subject the scale to sudden temperature changes, which may result in unstable weight readings.

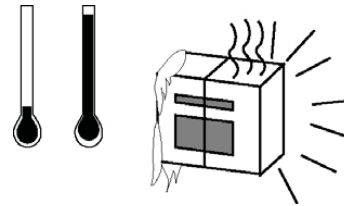

Insure that the indicator has good, clean AC power and is properly grounded. In areas subject to lightning strikes, additional protection to minimize lightning damage, such as surge suppressors, should be installed.

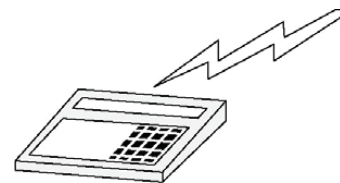
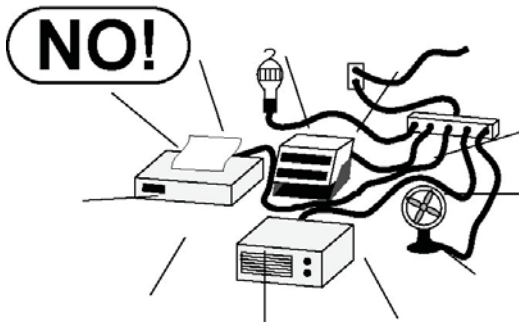

SITE PREPARATION REQUIREMENTS, CONT.

Electrical Power

The scale has been designed to operate from 100 to 240 VAC @ 0.4A Max. at 50/60 Hz. Note that a special order is not required for operation at 230/240 VAC.



WARNING! - To avoid electrical hazard and possible damage to the scale, DO NOT, under any circumstance, cut, remove, alter, or in any way bypass the power cord grounding prong.

- The socket-outlet supplying power to the scale should be on a separate circuit from the distribution panel and dedicated to the exclusive use of the scale.
- The socket-outlet shall be installed near the equipment and shall be easily accessible.
NOTE: The power cord on the scale serves as the power disconnect.
- The wiring should conform to national and local electrical codes and ordinances and should be approved by the local inspector to assure compliance.
- For outdoor operations, the socket-outlet must provide GFCI (ground fault circuit interrupter) protection.
- On installations requiring 230/240 VAC power, **it is the responsibility of the customer** to have a qualified electrician install the proper power cord plug that conforms to national electrical codes and local codes and ordinances.

Electrical Noise Interference

To prevent electrical noise interference, make certain all other wall outlets for use with air conditioning and heating equipment, lighting or other equipment with heavily inductive loads, such as welders, motors and solenoids are on circuits separate from the scale. Many of these disturbances originate within the building itself and can seriously affect the operation of the indicator. These sources of disturbances must be identified and steps must be taken to prevent possible adverse effects on the indicator. Examples of available alternatives include isolation transformers, power regulators, uninterruptible power supplies, or simple line filters.

INSTALLATION

Unpacking the Scale

Before beginning installation of the scale, make certain that it has been received in good condition. Carefully remove it from the shipping carton and inspect it for any evidence of damage (such as exterior dents and scratches) that may have taken place during shipment. Remove the packing material from the scale base and the protective covering from the indicator and commodity tray. *Keep the carton and packing material for return shipment if it should become necessary.* It is the responsibility of the purchaser to file all claims for any damages or loss incurred during transit.

Transporting the Scale

When you need to transport the scale, use the integral carrying handle located on the back of the display column to move the scale to another location.



Placing the Scale

The scale should be placed on a stable, vibration-free, level surface away from direct sunlight and any rapidly moving air source (heating and cooling vents).



CAUTION! DO NOT place the scale on any unstable cart, stand or table. The scale may fall causing injury to the operator, and damage to the unit, or proper operation of the scale may be inhibited.

Level the Scale

The scale must be set up and operated on a level surface. Level the scale by adjusting the four feet on the scale bottom, up or down, until the bubble in the level gauge is centered. After level is achieved, lock the feet in place by tightening the lock nuts against the scale bottom. **NOTE:** To view the level gauge, the commodity tray must not be installed.

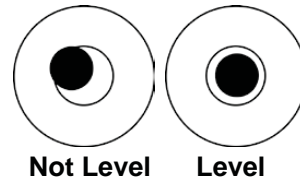

Installing the Commodity Tray

Tilt the tray at an angle and place the hooks on the back of the tray over the edge of the weighbridge. Lower the front of the tray to secure in place.



OPERATION



Keypad

The Admiral Series CA190 Bench Scale indicator is equipped with a 7-key Capacitive Touch keypad. The keypad is used to enter commands and data into the indicator. This section describes each key along with its normal function. It is helpful to refer to the actual indicator while reading this section.





The 190 indicator uses a capacitive touch keypad that requires a “finger touch” to function. The keypad will not operate with other items such as a pen, pencil or tools.



Key	Description
	<p>ON/OFF: The ON/OFF key is used to turn the scale on and off.</p> <p>Press the ON/OFF key when the scale is off to turn the scale ON. The 190 indicator will perform a display test (turn on all segments) and then show the model number and software version.</p> <p>If the scale is already on, press the ON/OFF key and hold for 2 to 3 seconds. When the display shows <i>OFF</i>, release the key to turn the scale OFF.</p>
	<p>ZERO: The ZERO key is used to zero the weight display. Up to the selected limit of 4% or 100% of the scale’s capacity can be zeroed. This limit is selected during the setup and calibration of the scale.</p> <p>Note that the indicator will not respond to pressing the ZERO key unless the weight display is stable.</p> <ul style="list-style-type: none"> • When displaying a Tare weight, pressing the ZERO key will clear the Tare value and set the display to Gross mode. • When displaying the Gross accumulator, pressing the ZERO key will clear the Gross accumulator. • When displaying the Net accumulator, pressing the ZERO key will clear the Net accumulator.

OPERATION, CONT.

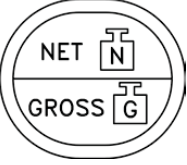
Keypad, Cont.

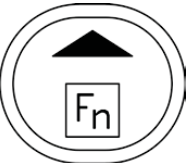
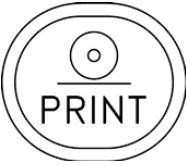
Key	Description
	<p>TARE ← (Enter): The TARE ← key is used during operation to store the current Gross weight as the new Tare weight. The display will change to the Net weight and the Net annunciator will turn on.</p>
	<p>NET/GROSS: The NET/GROSS key is used to toggle between the Gross and Net weight modes. The selected mode is indicated by turning on the appropriate annunciator on the display.</p> <p>Note that if no valid tare weight has been entered, pressing the NET/GROSS key will cause a momentary display error (<i>not RrE</i>) and the indicator will remain in the Gross weight mode.</p> <p>When in Hold, Count, Peak weight, Live weight, or Accumulator display mode, press the NET/GROSS key to return the display to normal weight display mode.</p>
	<p>UNITS/← (Left Arrow): The UNITS/← key is used to select the units in which the weight is to be displayed. The available units of measure ("unit1", "unit2" and "unit3") are selected in setup. The available units include pounds, ounces, kilograms, and grams.</p>
	<p>Fn/▲ (Up Arrow): The Fn/▲ key is used in conjunction with the other keys on the keypad to access additional indicator features.</p> <p>NOTE: Refer to the 190 Technical and Operation Manual, 8400-M022-O1, for more information on the Fn/▲ key functions.</p>
	<p>PRINT: Pressing the PRINT key during a weighing operation, will add the displayed Gross weight, or Net weight to the associated accumulator and send print ticket data to the serial interface selected during setup.</p> <p>NOTE: The indicator will not respond to pressing the PRINT key unless the weight display is stable.</p> <ul style="list-style-type: none"> • If displaying Gross weight, the only weight printed is Gross weight. • If displaying Net weight, the Gross, Tare, and Net weights are printed. • When in Gross weight accumulator display mode, pressing the PRINT key will print the Gross weight accumulator. • When in Net weight accumulator display mode, pressing the PRINT key will print the Net weight accumulator. • When in Peak weight display mode, pressing the PRINT key will print the Peak weight.

OPERATION, CONT.

Fn/▲ Key Functions

The Fn/▲ key is used to select several additional functions that may have been enabled during the setup and calibration of the indicator. Those functions include: Hold, Count, Time and Date, Peak Hold, Checkweigher, Live Weight, Weight Accumulation and Backlight Color.



NOTE: The Hold, Count and Live Weight functions cannot be enabled if the Legal-For-Trade option (*L F t = Y E S*) was selected during setup.

In addition, only one of the functions Hold, Count, Peak Hold, Checkweigher or Live Weight can be enabled at a time.

Description of Fn/▲ Key Functions

Function	Display	Description or Setting
Hold	<i>H o L d X</i>	X will be 1 if enabled, 0 if disabled
Count	<i>C o U n t X</i>	X will be 1 if enabled, 0 if disabled
Time and Date	HH:MM A	HH=hours, MM=minutes, A for AM, P for PM
	MM.DD.YY (<i>u S R = Y E S</i>)	MM=month, DD=day, YY=last two digits of year
	DD.MM.YY (<i>u S R = n o</i>)	
Peak Hold	<i>P h o L d X</i>	X will be 1 if enabled, 0 if disabled
Checkweigher	<i>L o =</i>	Minimum acceptable weight prompt
	<i>X*</i>	= minimum acceptable weight value. * When the value for <i>L o =</i> is greater than 0, the Checkweigher function is enabled.
	<i>H i =</i>	Maximum acceptable weight prompt. This prompt is displayed, when the value for <i>L o =</i> is greater than 0.
	<i>X</i>	= maximum acceptable weight value
Live Weight	<i>R c t X</i>	X will be 1 if enabled, 0 if disabled
Weight Accumulation	<i>R E C U X</i>	X will be 1 if enabled, 0 if disabled
Backlight Color	<i>C o L o r S</i>	Backlight Colors for normal operation and Checkweigher results



NOTE: Refer to the 190 Technical and Operation Manual, 8400-M022-O1, for more information on the Fn/▲ key functions.

OPERATION, CONT.

Annunciators

The Admiral Series CA190 Bench Scale indicator is equipped with annunciators that are turned on to indicate that the display is in the mode corresponding to the annunciator label or that the status indicated by the label is active. This section describes each annunciator.

Symbol	Name	Description
→0←	ZERO	This annunciator is turned on to indicate that the weight displayed is within $\pm 1/4$ division of true zero.
▾	STABLE	This annunciator is turned on when the weight display is stable. When off, it means that the change in successive weight samples is greater than the motion limits selected during setup.
n	NET	This annunciator is turned on when the displayed weight is Net weight (Gross weight less Tare weight).
G	GROSS	This annunciator is turned on to show that gross weight is displayed. Gross weight will be displayed when no tare weight is stored.
T	TARE	This annunciator is turned on to show that the displayed weight is the tare weight.
lb	pounds	This annunciator is located to the right of the weight display and is turned on to show that the displayed weight unit is pounds.
oz	ounces	This annunciator is located to the right of the weight display and is turned on to show that the displayed weight unit is ounces.
kg	kilograms	This annunciator is located to the right of the weight display and is used to indicate that the displayed unit of weight measurement is kilograms.
g	grams	This annunciator is located to the right of the weight display and is used to indicate that the displayed unit of weight measurement is grams.
[COUNT	This annunciator shows that the display is in the Count mode and the value displayed is in pieces (the count quantity) and not weight.
[And A or n And A	ACCUMULATOR	This annunciator shows that the displayed value is the content of the accumulator.
▼ IN1	DIGITAL INPUT	This annunciator is used to signal that a remote key function has been activated. Note that this annunciator is active only when the Digital Input feature has been enabled.
▼ OUT1 <	UNDER	This annunciator is used to signal that the displayed weight is less than the minimum value of acceptable weight used in the Checkweigher feature or that preset 1 is active. Note that this annunciator is active only when the Checkweigher feature or the preset feature has been enabled.

OPERATION, CONT.

Annunciators, Cont.

<p>▼ OUT2 ⊕</p>	<p>ACCEPT</p>	<p>This annunciator is used to signal that the displayed weight is within the acceptable weight limits for the Checkweigher feature.</p> <p>That is, the weight is equal to or greater than the minimum acceptable weight and equal to or less than the maximum acceptable weight.</p> <p>This annunciator is also used to indicate that preset 2 is active.</p> <p>Note that this annunciator is active only when the Checkweigher feature or the preset feature has been enabled.</p>
<p>▼ OUT3 ></p>	<p>OVER</p>	<p>This annunciator is used to signal that the displayed weight is equal to or greater than the minimum value of overweight used in the Checkweigher feature</p> <p>This annunciator is also used to indicate that preset 3 is active.</p> <p>Note that this annunciator is active only when the Checkweigher feature or the preset feature has been enabled.</p>

OPERATION, CONT.

Checkweigher

With the Checkweigher function enabled during setup of the indicator, the function must be activated before it can be used.

Refer to the 190 Technical and Operation Manual, 8400-M022-O1, section 4.14 Function Setup, the *FUNC (FUNC?)* parameter to enable the **Fn/▲** key Checkweigher function.

Target Weight Setup

1. Press and hold the **Fn/▲** key until the display blanks.
2. Once the display blanks, release the **Fn/▲** key
3. The display will change to show the first function prompt.
4. Repeatedly press the **TARE ↵** key until the *L o 1=* prompt is displayed.
5. Press the **TARE ↵** key once again.
6. The display will show the current value for the minimum acceptable weight for ID 1.
7. If the setting displayed is acceptable, press the **TARE ↵** key to save it.
8. Otherwise, use the **Fn/▲** and **UNITS/◀** keys to enter a new value for the minimum acceptable weight for ID 1.
9. When the desired weight value is displayed, press the **TARE ↵** key to save it.
10. The display will change to show the *H i 1=* prompt.
11. Press the **TARE** key again.
12. The display will show the current value for the maximum acceptable weight for ID 1.
13. If the setting displayed is acceptable, press the **TARE** key to save it.
14. Otherwise, use the **Fn/▲** key and **UNITS/◀** key to enter a new value for the maximum acceptable weight for ID 1.
15. When the desired value is displayed, press the **TARE** key to save it.
16. The display will change to show the *L o 2=* prompt.
17. Repeat steps **5-9** above to set the value for the minimum acceptable weight for ID 2.
18. The display will change to show the *H i 2=* prompt.
19. Repeat steps **11-15** above to set the value for the maximum acceptable weight for ID 2.
20. Continue to enter minimum and maximum acceptable weights for the remaining ID's for up to ten (10) ID's, or press the **UNITS/◀** key at the *L o n=* prompt or the *H i n=* prompt to skip the entry of the remaining weights.
21. Repeatedly press the **TARE** key to step through the remaining function prompts until the indicator returns to the weight display.
22. Note that if low weight for ID 1 is set to 0, the Checkweigher function will be *disabled*. The low and high weights must be less than scale capacity and the high weight must be greater than the low weight.

OPERATION, CONT.

Checkweigher, Cont.

Target Weight Selection

1. From the weight display, briefly press and then release the **Fn/▲** key.
2. The display will show the prompt $id =$.
3. Press the **TARE** key.
4. The display will show the ID of the currently selected target weight.
5. If the setting displayed is acceptable, press the **TARE** key to save it.
6. Otherwise, use the **Fn/▲** key to enter a new value for the ID.
7. When the desired value is displayed, press the **TARE** key to save it.
8. The indicator will return to the weight display.

Checkweigher Operation

With the Checkweigher function enabled and activated, during operation the indicator will compare the displayed weight with the preset values and display the results as under, accept, or over.

When the displayed weight is less than the minimum acceptable weight, the arrow over **OUT1 <** (the UNDER annunciator) will turn on and the display will change to the color selected in section 4.15, Display Backlight Color Setup.

When the displayed weight is greater than the maximum acceptable weight, the arrow over **OUT3 >** (the OVER annunciator) will turn on and the display will change to the color selected in section 4.15, Display Backlight Color Setup.

When the displayed weight is within the range from minimum acceptable weight to maximum acceptable weight, the arrow over **OUT2 ⊕** (the ACCEPT annunciator) will turn on and the display will change to the color selected in section 4.15, Display Backlight Color Setup.

BP190 - OPTIONAL BATTERY

The Admiral Series CA190 Bench Scale can operate from an optional rechargeable Lithium Ion battery. If you wish to operate the scale from a battery, you must first obtain and install the BP190 optional battery. The battery can be purchased from the Cardinal Scale Parts Department. Phone: (800) 641-2045 or email: parts@cardet.com.

BP190 Contents:

QTY	PART NUMBER	DESCRIPTION
2	6610-5033	CABLE TIE LARGE 8" SST2SM
1	6800-1072	BATTERY PACK LI-ION 7.2V, 2600 mAH 6" LEADS

Installing the BP190

1. Loosen the 4 Captive screws securing the rear housing to the front housing assembly.
2. Remove the 5-connector terminal block from P2 on the 190 main board.
3. Referring to labels on circuit board for terminal connections, connect each wire to terminal block.
4. To terminate a wire, loosen the screws in the terminal block and then insert the wire into the terminal opening. Tighten the screw to secure the wire in place. Repeat the procedure until both wires are in place.

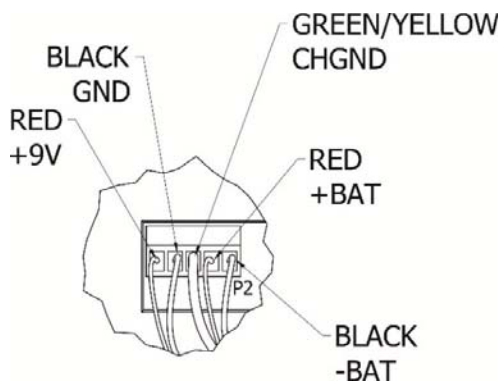

5. Insert two (2) cable ties through slots in the power supply cover as shown on the next page.
NOTE: If your power supply cover does not have two (2) slots, connect two (2) cable ties together and secure battery by sliding cable tie behind power supply cover and over battery pack as shown on the next page. *Make sure the cable tie connections are on the top of batteries and not the front of batteries.*
6. Place the battery pack on the power supply cover.
7. Secure the battery pack to the power supply cover with the cable ties.
8. Insert the 5-connector terminal block removed in step 2 into P2 on the 190 main board.
9. Make certain no cables or wires are exposed between the rear housing and front housing assembly and then place the front housing assembly onto the rear housing.
10. Secure by tightening the 4 Captive screws loosened earlier.
11. The scale is ready for normal operations.

BP190 - OPTIONAL BATTERY, CONT.

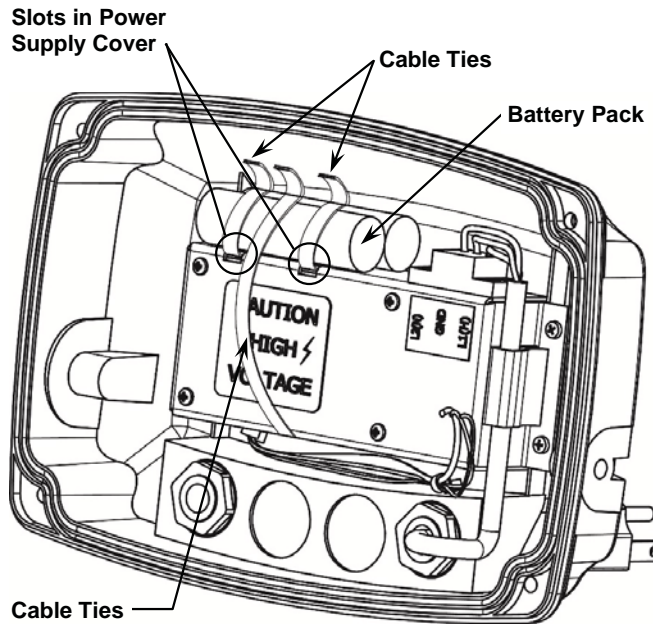

Cable Ties
Connected Together
See Step 5 Note and
Images Below.



CORRECT!
Position Cable Ties
Connection on Top of
Batteries.



WRONG!
Do Not Position Cable
Ties Connection on
Front of Batteries.

Battery Status

The battery status indicator will be displayed when a battery pack is installed. The number of bars indicates the level of charge. Note that as the battery approaches full discharge, the outline of the battery will start to flash.



Number of Bars	Level of Charge
4	100%
3	75%
2	50%
1	25%



NOTE: When the indicator is connected to an external power supply and is charging the battery, the charge level status bars will scroll.

BP190 - OPTIONAL BATTERY, CONT.

Charging

To recharge the battery pack, the AC power adapter must be connected to an AC power outlet and plugged into the indicator. It will take approximately six (6) hours to fully recharge the battery pack in the indicator. While the battery pack is charging the indicator can still be operated. **NOTE:** Charging the battery pack for more than six (6) hours *will not* damage it.

Charging Guidelines

- **DO NOT** charge battery below freezing.
- **DO NOT** charge battery above 40 C.
- Lithium-ion does not need to be fully charged; a partial charge is acceptable.
- Battery does not need to be fully discharge between charging cycles.

Refer to the 190 Technical and Operation Manual, 8400-M022-O1, for more information on battery operation.

CARE AND CLEANING

The Admiral Series CA190 bench scale is comprised of a IP69K rated indicator and a wash-down base that may be cleaned using high pressure, high temperature wash-down procedures or hand cleaned with detergents and water. **NOTE:** The high pressure, high temperature spray should be no closer than 4 to 6 inches, with the pressure between 1160 to 1450 PSI and the temperature limited to 176 °F.



General Cleaning Precautions

Scale and Commodity Tray

While stainless steel is a sturdy and attractive material, it is not incorruptible. Stainless steel is susceptible to rusting. There are three basic things which can break down stainless steel's outer layer and allow corrosion.

1. Mechanical abrasion - those things which will scratch the steel's surface, such as steel pads, wire brushes and scrapers.
Instead, use soft cloths, sponges or plastic scouring pads for cleaning and brush with the polish line or "grain." Clean food equipment frequently to avoid build-up.
2. Water - especially hard water which can leave behind deposits. When possible use treated water - soft water is much gentler on the stainless steel's surface.
3. Chlorides - often found in water, food and table salt. One of the worst perpetrators of chlorides can come from household and industrial cleaners, especially those with quaternary salts. Never use hydrochloric acid (muriatic acid) on stainless steel.

Instead, use non-chloride cleaners. If chlorinated cleaners must be used, rinse several times and wipe dry immediately.

Indicator

- Do not use wire brushes, abrasives, or cleaning tools such as steel pads and scrapers, which will scratch the surface. Instead, use soft cloths, sponges or plastic scouring pads for cleaning. Clean food equipment frequently to avoid build-up.
- Avoid the use of acetone, thinner or other volatile solvents and abrasive type cleaners for cleaning. If required, a mild solvent such as mineral spirits can be used to remove oil, grease, tars, wax, and similar substances. Use a cloth dampened with mineral spirits and apply only to areas that are contaminated. Follow up the use of this mild solvent with detergent cleaning and rinsing.
- When possible use treated water. Hard water can leave behind deposits. Soft water is much gentler on the indicator's surface.

BEFORE YOU CALL FOR SERVICE

The Admiral Series CA190 Bench Scale has been designed to provide you with years of trouble-free operation. However, should you experience a problem, please refer to the troubleshooting guide below before you call for service. The following describes several types of symptoms along with suggested remedies.

PROBLEM	POSSIBLE SOLUTIONS
Display does not turn on	<p>AC operation:</p> <p>Is the AC power cord fully inserted into the wall receptacle?</p> <p>Check wall receptacle for proper AC power.</p> <p>Try another electrical appliance in the same receptacle, does it work?</p> <p>Check the circuit breaker.</p> <p>Has there been power failure?</p> <p>Battery operation:</p> <p>Check if battery is installed correctly.</p> <p>Is battery discharged? Recharge or replace.</p>
Incorrect weight displayed	<p>Has the indicator been calibrated?</p> <p>Insure that the scale platform isn't touching an adjacent object.</p> <p>Have proper operation procedures been followed?</p>
Indicator will not display weight	<p>Refer to Error Codes section and make certain that the "oL R P" message is not displayed. If so, and scale is not loaded, perform the calibration procedure.</p>

ERROR CODES

The indicator used on the Admiral Series CA190 Bench Scale is equipped with software that indicates when an error in the operation takes place. The following lists the error codes displayed along with their meaning. Should you encounter an error code, please refer to this list for the cause.

Error	Cause (A.) and Corrective Action (B.)
<i>CONF 19</i>	<p>A. Calibration required.</p> <p>B. Calibrate the scale with test weights.</p>
<i>ERRRH</i>	<p>A. The analog input is off scale at the upper end of the input range.</p> <p>B. Check wiring and load cell.</p>
<i>ERRRL</i>	<p>A. The analog input is off scale at the lower end of the input range.</p> <p>B. Check wiring and load cell.</p>
<i>Error</i>	<p>A. Attempt to perform an illegal function:</p> <ol style="list-style-type: none"> 1. Performing a hold operation when the weight is invalid (e.g., overcapacity). 2. Attempting to clear Tare with Gross weight greater than zero (<i>LFt = 1, uSR = 0</i>). 3. Attempting to zero scale when there is motion present or the scale is over capacity. 4. Attempting to zero scale when Gross weight is out of zero range (<i>tRL = 4E5</i>). 5. Attempting to print when scale is over capacity. 6. Attempting to do a span adjustment with insufficient load on the scale. 7. Attempting to tare scale when there is motion present or the Gross weight is below zero or over capacity.
<i>Lo bAt</i>	<p>A. This message is used with the battery operation and will turn ON to indicate the battery does not have a sufficient charge and requires recharging.</p> <p>If continued use furthers drains the battery, no change in operation will occur until just before the battery voltage drops to a level where operation is affected. At this level, the indicator will automatically turn off.</p> <p>B. Charge the battery pack or replace it.</p>
<i>no tArE</i>	The NET/GROSS key was pressed when there is no stored tare.
<i>oCAP</i>	<p>A. The load on the scale exceeds the capacity of the scale.</p> <p>B. Remove the excess load.</p>
<i>-oF-</i>	<p>A. The indicator is trying to display a positive number with more than six digits or a negative number with more than five digits.</p> <p>B. Return to Gross weight mode and review the Tare weight. Might indicate incorrect calibration.</p>
<i>UnStb</i>	<p>A. Motion was present when a print was initiated.</p> <p>B. Wait for a stable indication before printing.</p>

PARTS IDENTIFICATION

ITEM NO.	QTY.	PART NUMBER	DESCRIPTION
1	1	1960-0646-0A	BASE/COLUMN
2	1	1960-0647-08	WEIGHBRIDGE
3	1	SSPW-20KG	LOAD CELL, CA8-15KGW-190
	1	SSPW-20KG	LOAD CELL, CA8-30W-190
	1	SSPW-75KG	LOAD CELL, CA12-60KGW-190
	1	SSPW-75KG	LOAD CELL, CA12-120W-190
5	1	1960-D558-08	COMMODITY TRAY
6	2	1960-0650-08	LOAD CELL SPACER
7	4	6540-1202	LEVELER FEET
8	4	6007-0103	BLT HEX HD 5/16-18 UNC X 2 1/2" S.S.
9	4	6021-2085	SCW BUTTON HD M8-1.25 X 14MM S.S.
10	4	6021-2086	BLT SOC HD M8-1.85 X 14MM S.S.
11	4	6013-0020	NUT ELASTIC 3/8-16 UNC S.S.
12	4	6013-0075	NUT HEX JAM 3/8-16 UNC S.S.
13	4	6013-0057	NUT HEX 5/16-18 UNC S.S.
14	1	6690-0001	LEVEL BULLSEYE
15	1	8542-B096-08	GROUND CLIP
16	4	6540-1160	STEM BUMPER
17	2	6024-0083	WASHER
18	2	6540-1053	KNOB ENCL.
19	1	6540-1104	PLUG.
20	2	6024-0140	WASHER
21	A/R	6560-1072	LOCITE #499 OR EQUAL
22	1	593M729	SERIAL TAG
23	4	6680-2101	RIVET POP
24	-	190	INDICATOR SHOWN FOR REFERENCE
25	-	190DC	INDICATOR SHOWN FOR REFERENCE
26	1	6980-0014	CABLE TIE
27	.01	6560-0007	ANTI-SEIZE

PARTS IDENTIFICATION, CONT.

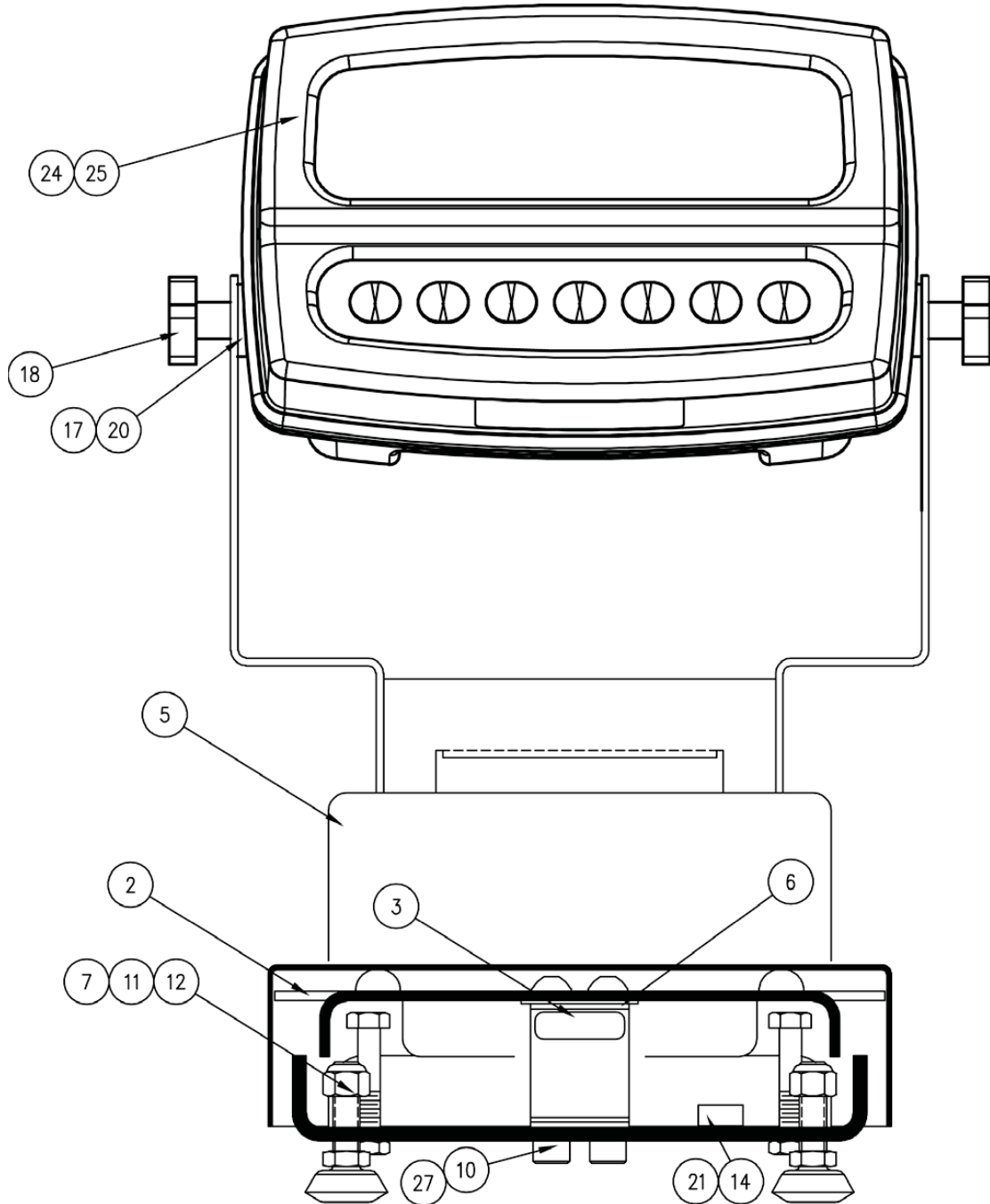

PARTS IDENTIFICATION, CONT.

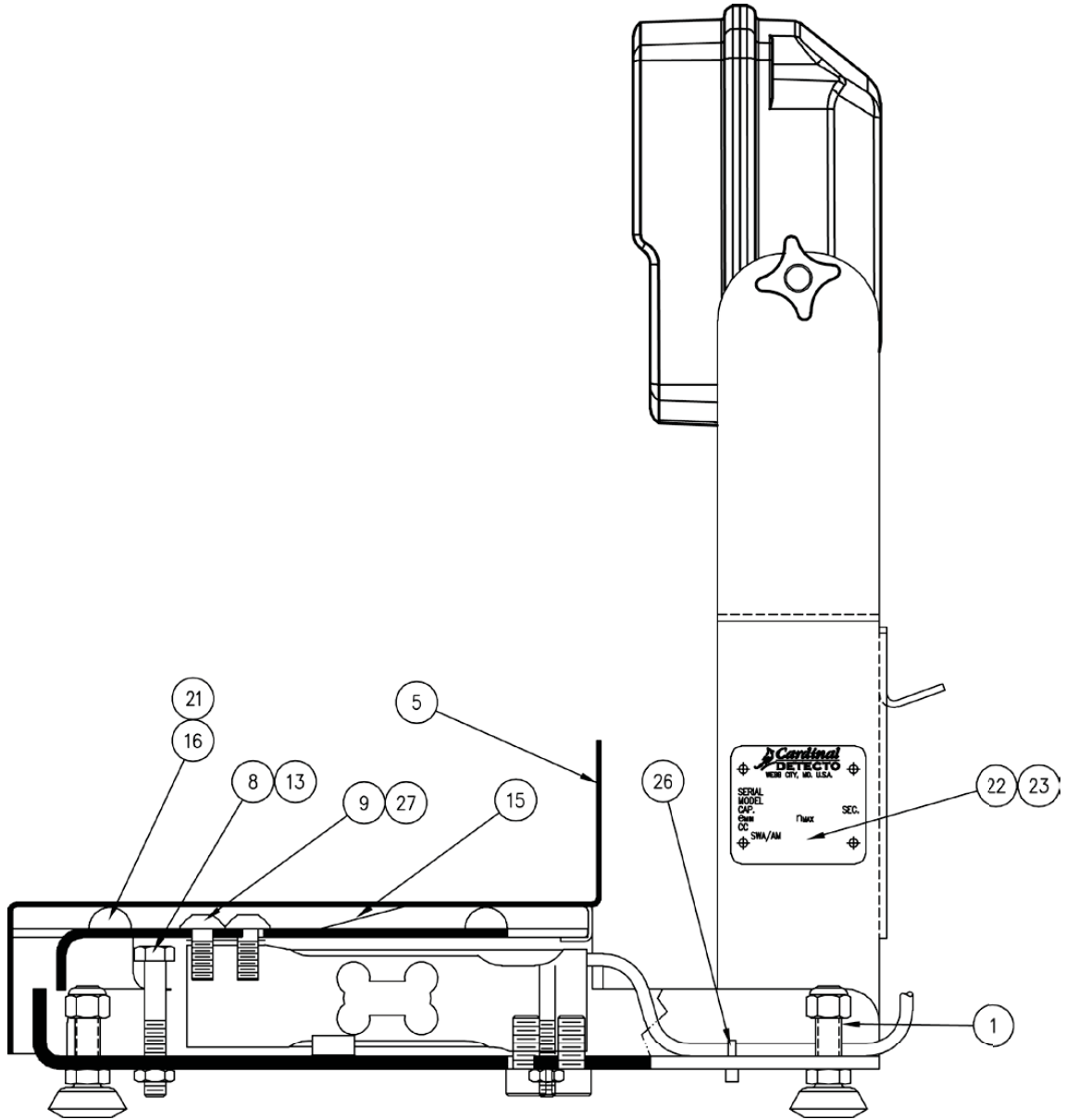

STATEMENT OF LIMITED WARRANTY

WARRANTY TERMS

Cardinal Scale Manufacturing Company warrants the equipment we manufacture against defects in material and workmanship. The length and terms and conditions of these warranties vary with the type of product and are summarized below:

PRODUCT TYPE	TERM	MATERIAL AND WORKMANSHIP	LIGHTNING DAMAGE See note 9	WATER DAMAGE See note 7	CORROSION See note 4	ON-SITE LABOR	LIMITATIONS AND REQUIREMENTS
WEIGHT INDICATORS	90 DAY REPLACEMENT ----- 1 YEAR PARTS	YES	YES	YES	YES	NO	1, 2, 3, 5, 6 A, B, C, D
LOAD CELLS (Excluding Hydraulic)	1 YEAR	YES	YES	YES	YES	NO	1, 2, 3, 5, 6 A, B, C, D
HYDRAULIC LOAD CELLS (When purchased with Guardian Vehicle Scale)	LIFETIME	YES	YES	YES	YES	90 DAYS	1, 5, 6, 8 A, B, C, D
HYDRAULIC LOAD CELLS (When purchased separately)	10 YEARS	YES	YES	YES	YES	NO	1, 5, 6, 8, 9 A, B, C, D
VEHICLE SCALE (Deck and Below Excl. PSC Series)	5 YEARS	YES	YES	YES	YES	90 DAYS	1, 2, 3, 5, 6 A, B, C, D, E
LSC SCALE (Deck and Below)	3 YEARS	YES	YES	YES	YES	90 DAYS	1, 2, 3, 5, 6, 11 A, B, C, D
GUARDIAN FLOOR SCALES	10 YEARS	YES	YES	YES	YES	NO	1, 2, 3, 5, 6, 9, 10 A, B, C, D
ALL OTHER CARDINAL PRODUCTS	1 YEAR	YES	YES	YES	YES	NO	1, 2, 5, 6 A, B, C, D, E
REPLACEMENT PARTS	90 DAYS	YES	YES	YES	YES	NO	1, 2, 4, 5, 6 A, B, C, D
SWIM AND 760 SERIES VEHICLE SCALES	1 YEAR	YES	YES	YES	YES	90 DAYS	1, 2, 5, 6 A, B, C, D
SOFTWARE	90 DAYS	YES	N/A	N/A	N/A	NO	1, 6 B, C, D
CONVEYOR BELT SCALES (including Belt-Way)	1 YEAR	YES	YES	YES	YES	NO	1, 2, 3, 5, 6 A, B, C, D, E, F



CARDINAL

Ph. (800) 441-4237
E-mail: cardinal@cardet.com
102 E. Daugherty
Webb City, MO 64870

04/24
Printed in USA
315-WARRANTY-CAR-M

APPLICABLE LIMITATIONS AND REQUIREMENTS

1. This warranty applies only to the original purchaser. The warranty does not apply to equipment that has been tampered with, defaced, damaged, or had repairs or modifications not authorized by Cardinal or has had the serial number altered, defaced or removed.
2. This warranty is not applicable to equipment that has not been grounded in accordance with Cardinal's recommendations.
3. This equipment must be installed and continuously maintained by an authorized Cardinal / Belt-Way dealer.
4. Applies only to components constructed from stainless steel.
5. This warranty does not apply to equipment damaged in transit. Claims for such damage must be made with the responsible freight carrier in accordance with freight carrier regulations.
6. Warranty term begins with date of shipment from Cardinal.
7. Only if device is rated NEMA 4 or better or IP equivalent.
8. Lifetime warranty applies to damages resulting from water, lightning, and voltage transients and applies only to the hydraulic load cell structure itself (does not include pressure transducers, rubber seals, o-rings, and associated wiring).
9. 10-Year prorated warranty on hydraulic load cells.
10. 1-Year warranty for scale structure.
11. PSC models' warranty coverage applies only to agricultural installations on farms up to 3,000 acres (LSC models not limited in this manner).
12. Load cell kits MUST be installed in accordance with Cardinal Scale instructions. Failure to follow these instructions will void the warranty.

EXCLUSIONS

- A.) This warranty does not include replacement of consumable or expendable parts. The warranty does not apply to any item that has been damaged due to unusual wear, abuse, improper line voltage, overloading, theft, fire, water, prolonged storage or exposure while in purchaser's possession or acts of God unless otherwise stated herein.
- B.) This warranty does not apply to peripheral equipment not manufactured by Cardinal. This equipment will normally be covered by the equipment manufacturer's warranty.
- C.) This warranty sets forth the extent of our liability for breach of any warranty or deficiency in connection with the sale or use of our product. Cardinal will not be liable for consequential damages of any nature, including but not limited to loss of profit, delays or expenses, whether based on tort or contract. Cardinal reserves the right to incorporate improvements in material and design without notice and is not obligated to incorporate said improvements in equipment previously manufactured.
- D.) This warranty is in lieu of all other warranties expressed or implied including any warranty that extends beyond the description of the product including any warranty of merchantability or fitness for a particular purpose. This warranty covers only those Cardinal products installed in the forty-eight contiguous United States and Canada.
- E.) This warranty does not cover paint coatings due to the variety of environmental conditions.
- F.) Do not cut load cell cables on load cells returned for credit or warranty replacement. Cutting the cable will void the warranty.
- G.) Software is warranted only for performance of the functions listed in the software manual and/or the Cardinal proposal.
- H.) The software warranty does not cover hardware. Warranties on hardware are provided from the hardware vendor only.
- I.) The software warranty does not cover interfacing issues to non-Cardinal supplied hardware.
- J.) The software warranty does not include automatic software upgrades unless purchased separately.



Ph. (800) 441-4237
E-mail: cardinal@cardet.com
102 E. Daugherty
Webb City, MO 64870

04/24
Printed in USA
315-WARRANTY-CAR-M

Cardinal Scale Mfg. Co.

102 E. Daugherty, Webb City, MO 64870 USA

Ph: 417-673-4631 or 1-800-641-2008

Fax: 417-673-2153

www.cardinalscale.com

Technical Support: 1-866-254-8261

E-mail: tech@cardet.com

Printed in USA

1960-0652-0M Rev A 09/17