

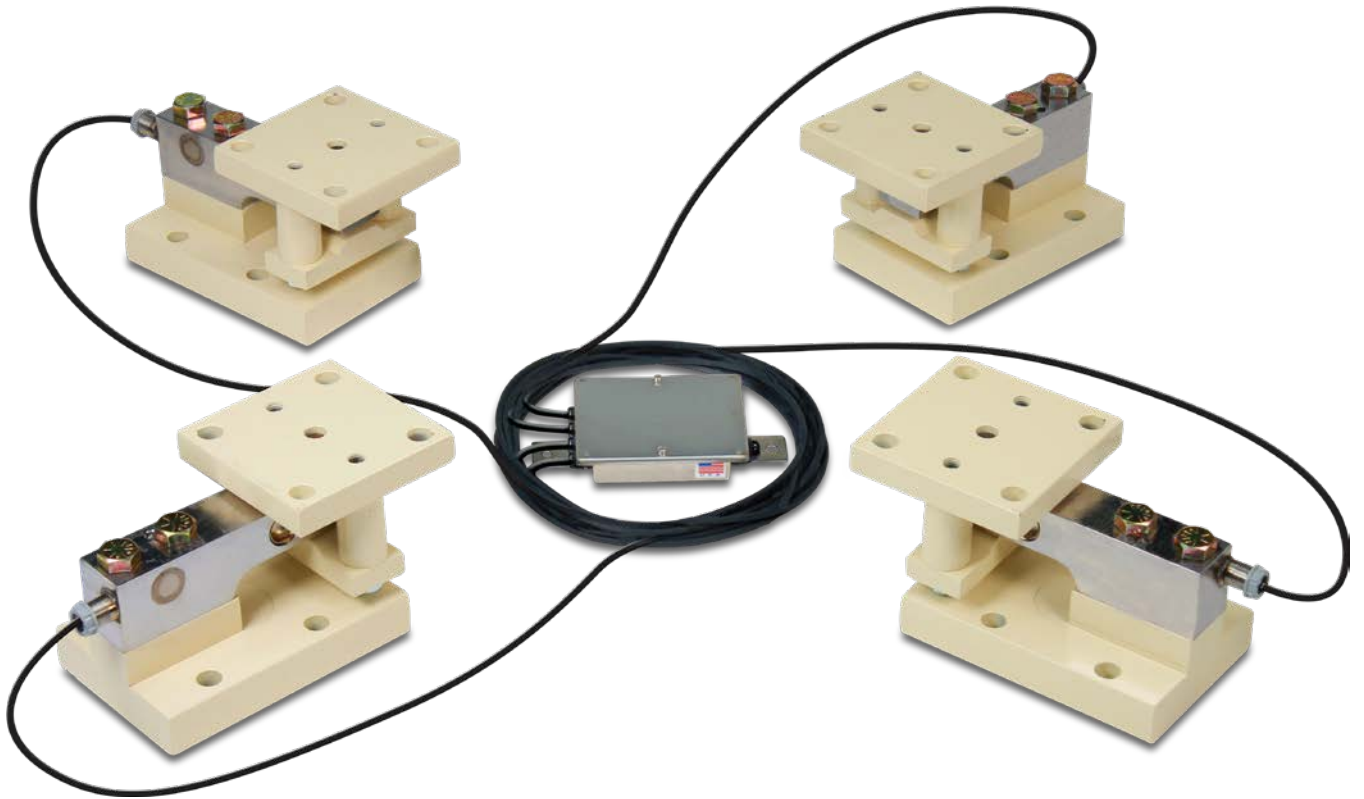

CARDINAL®



THBC
Self-Checking
Load Cell Kits
Technical Manual

TABLE OF CONTENTS

INTRODUCTION	1
SPECIFICATIONS	2
Dimensions	3
Capacities	4
GENERAL INSTALLATION GUIDELINES	5
INSTALLATION	6
LOAD CELL WIRING	7
SB Series Wiring Color Code	7
JUNCTION BOX WIRING	8
Load Cell Wiring Color Code	8
LOAD CELL REPLACEMENT	9
PARTS IDENTIFICATION	11

Serial Number _____
Date of Purchase _____
Purchased From _____

RETAIN THIS INFORMATION FOR FUTURE USE

PRECAUTIONS	
Before using this product, read this manual and pay special attention to all "NOTIFICATION" symbols:	
	DANGER! WARNING! CAUTION!

Copyright

All rights reserved. Reproduction or use, without expressed written permission, of editorial or pictorial content, in any manner, is prohibited. No patent liability is assumed with respect to the use of the information contained herein.

Disclaimer

While every precaution has been taken in the preparation of this manual, the Seller assumes no responsibility for errors or omissions. Neither is any liability assumed for damages resulting from use of the information contained herein. All instructions and diagrams have been checked for accuracy and ease of application; however, success and safety in working with tools depend largely upon the individual accuracy, skill and caution. For this reason, the Seller is not able to guarantee the result of any procedure contained herein. Nor can they assume responsibility for any damage to property or injury to persons occasioned from the procedures. Persons engaging the procedures do so entirely at their own risk.

FCC Compliance Statement

This equipment generates uses, can radiate radio frequency, and if not installed and used in accordance with the instruction manual, may cause interference to radio communications. It has been designed within the limits for a Class A computing device pursuant to Subpart J of Part 15 of FCC rules to provide reasonable protection against such interference when operated in a commercial environment. Operation of this equipment in a residential area may cause interference in which case the user will be responsible to take whatever measures necessary to correct the interference.

You may find the booklet “How to Identify and Resolve Radio TV Interference Problems” prepared by the Federal Communications Commission helpful. It is available from the U.S. Government Printing Office, Washington, D.C. 20402. Request stock No. 001-000-00315-4.

INTRODUCTION

Cardinal Scale's THBC electronic load cell kits are ideal for weighing tanks, hoppers, mixers, and conveyors. These self-checking load cell kits are available with mild steel or stainless steel stands, system capacities ranging from 7,500 lb (3,400 kg) up to 200,000 lb (90,700 kg), and stainless steel waterproof load cells.

The THBC kits are ideal for medium-to-heavy capacity tank and hopper weighing, new or existing installations, and accommodate multi-legged tanks with up to 10 legs. They offer an easy-to-install, low profile, bolt-down design. Each kit comes complete with 3 or 4 stainless steel load cells, self-checking load cell stands, load cell cable, and a stainless steel junction box. Special self-centering load buttons protect against offset side loads.

The rugged, environmentally sealed SB series shear beam load cells, also manufactured by Cardinal Scale, are NTEP, OIML, and VCAP certified.

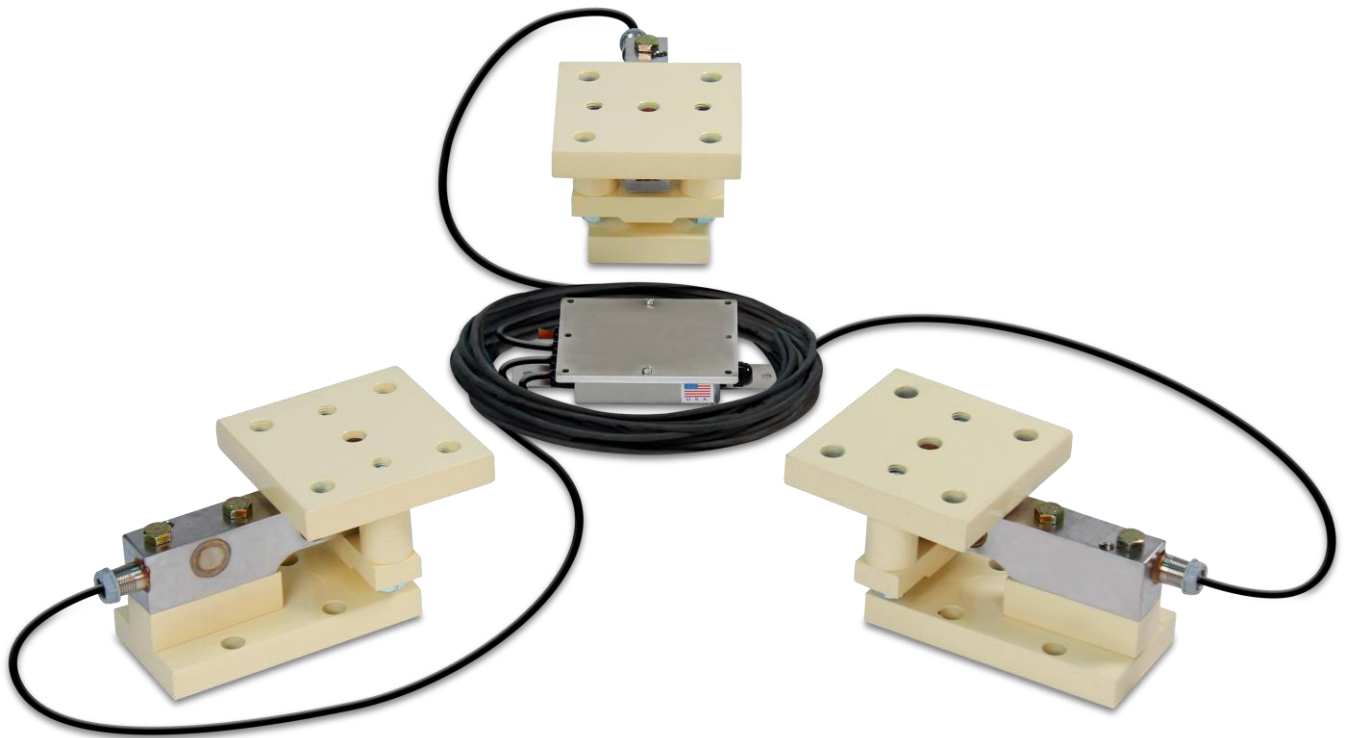

This manual should be studied thoroughly before attempting to install the tank scale kit, and must be used in conjunction with certified drawings of the particular scale being installed.

In case of conflict, the certified drawings will govern.

Safety should always be the prime consideration during all phases of the installation. Failure to comply with the instructions in this manual will void all warranty implied or stated.

By purchase of this tank scale kit, the customer confirms that a qualified engineer has determined that the vessel to be used is structurally sound and capable of being supported by three or four points when filled to capacity.

SPECIFICATIONS

Specification	Description
Model:	THBC series
Standard Model Capacities:	7,500 lb (3,400 kg) up to 80,000 lb (36,000 kg)
Load Cell Type:	Stainless steel SB series shear beam load cells
Load Cell Cable:	20 ft / 6 m
Stand Type:	Self-checking, bolt-down design
Stand Construction:	Stainless steel or powder-painted mild steel
Junction Box Type:	Stainless steel 4 cell trim box
Junction Box Cable Length to Indicator:	30 ft / 9 m with 9-pin D connector
Included:	Each kit consists of 3 or 4 self-checking stand assemblies, 3 or 4 stainless steel load cells, load cell cable, and 1 stainless steel NEMA 4 junction box.
Indicators:	A wide selection of digital weight indicators are also available from Cardinal Scale
Applications:	Load cell assemblies available for tank, hopper, mixer, and conveyor weighing

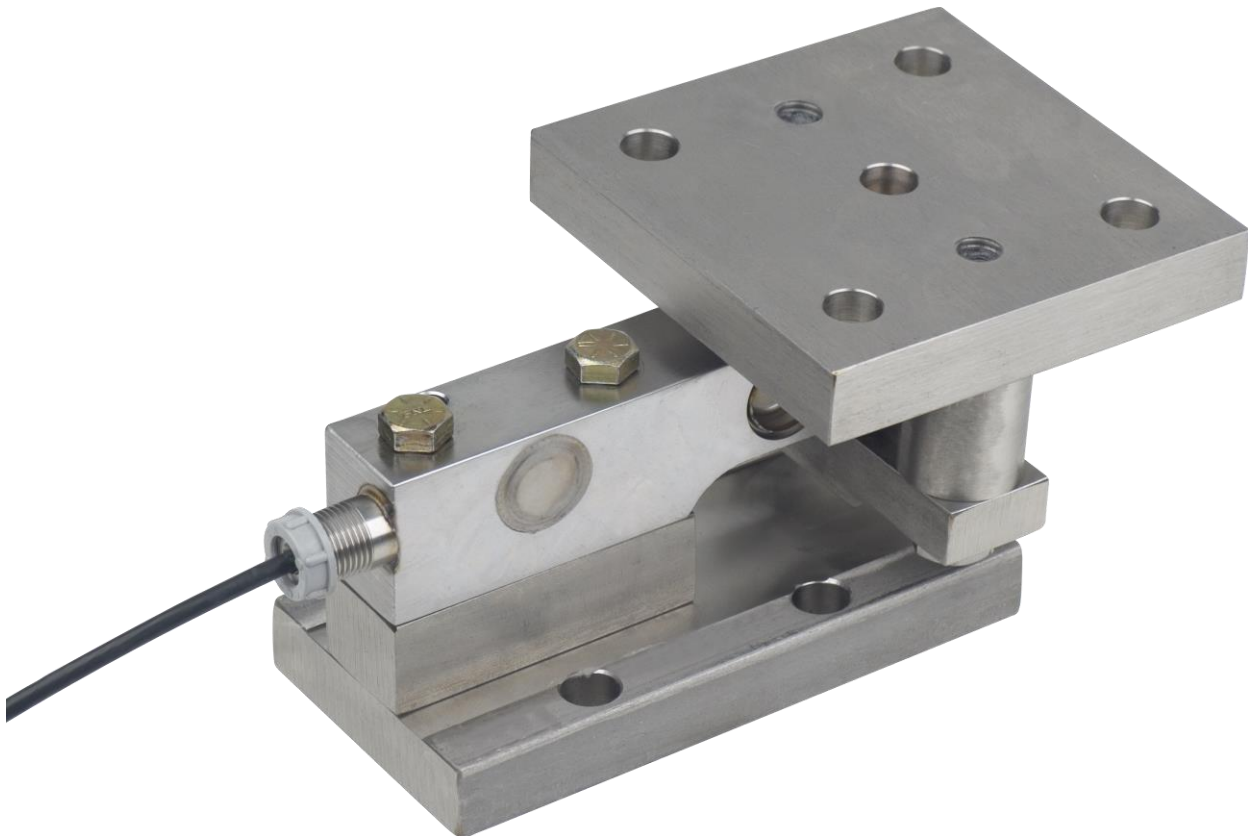

SPECIFICATIONS, CONT.

Dimensions

		THBC Dimensions 2,500 / 5,000-lb (1,134 / 2,268-kg) Capacities		THBC Dimensions 10,000 / 20,000-lb (4,536 / 9,072-kg) Capacities	
		INCHES	MM	INCHES	MM
TOP	A	6.0	152.4	6.0	152.4
	B	4.0	101.6	4.5	114.3
	C	1.0	25.4	0.8	19.1
	D	2.0	50.8	2.0	50.8
	E	∅0.7	∅17.5	∅0.8	∅19.8
	F	4.0	101.6	4.5	114.3
	G	6.0	152.4	6.0	152.4
	H	1.0	25.4	0.8	19.1
BOTTOM	I	8.0	203.2	9.0	228.6
	J	2.1	54.0	2.0	50.8
	K	3.3	82.6	4.0	101.6
	L	4.0	101.6	6.0	152.4
	M	0.5	12.7	0.8	19.1
	N	3.0	76.2	4.5	114.3
	O	∅0.7	∅17.5	∅0.8	∅19.8
SIDE	P	4.8	120.7	6.0	153.2
	Q	10.1	257.2	11.0	279.4
END	R	5.4	138.1	6.4	164.1
	S	1.0	25.4	1.0	25.4
	T	1.0	25.4	1.5	37.8

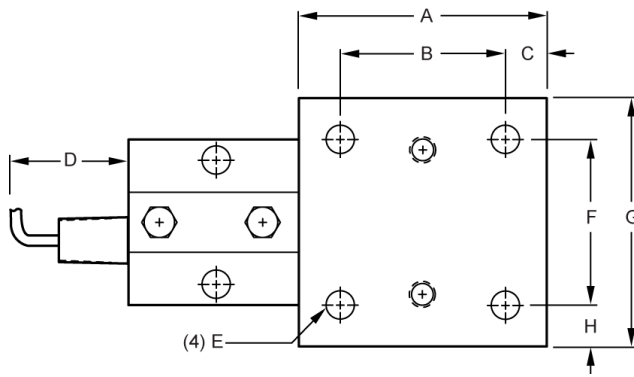

Top View

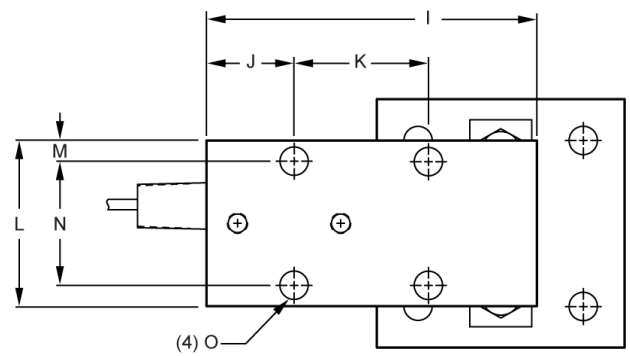

Bottom View

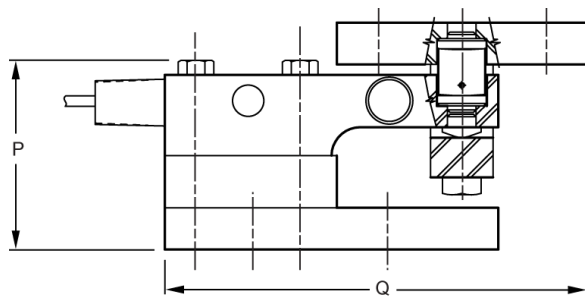

Side View

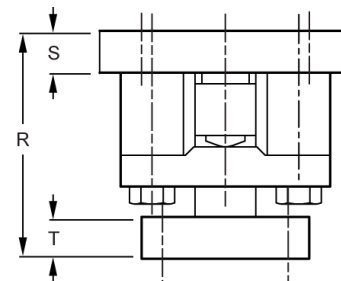

End View

SPECIFICATIONS, CONT.

Capacities

Kits consists of 3 self-checking stand assemblies, 3 stainless steel load cells, 3 mild or stainless steel steel stands and 1 stainless steel, NEMA 4 junction box.

		Model	Cell Capacity	System Capacity	Shipping Weight
3 CELL SYSTEMS	MILD STEEL	THBC2.5-3	2,500 lb - 1,135 kg	7,500 lb - 3,405 kg	120 lb / 54 kg
		THBC5-3	5,000 lb - 2,270 kg	15,000 lb - 6,805 kg	120 lb / 54 kg
		THBC10-3	10,000 lb - 4,535 kg	30,000 lb - 13,610 kg	180 lb / 82 kg
		THBC20-3	20,000 lb - 9,070 kg	60,000 lb - 27,215 kg	190 lb / 86 kg
	STAINLESS STEEL	THBCS2.5-3	2,500 lb - 1,135 kg	7,500 lb - 3,405 kg	120 lb / 54 kg
		THBCS5-3	5,000 lb - 2,270 kg	15,000 lb - 6,805 kg	120 lb / 54 kg
		THBCS10-3	10,000 lb - 4,535 kg	30,000 lb - 13,610 kg	180 lb / 82 kg
		THBCS20-3	20,000 lb - 9,070 kg	60,000 lb - 27,215 kg	190 lb / 86 kg

Kits consists of 4 self-checking stand assemblies, 4 stainless steel load cells, 4 mild or stainless steel steel stands and 1 stainless steel, NEMA 4 junction box.
Load Cell NTEP No. 87-059A1.

		Model	Cell Capacity	System Capacity	Shipping Weight
4 CELL SYSTEMS	MILD STEEL	THBC2.5-4	2,500 lb - 1,135 kg	10,000 lb - 4,540 kg	160 lb / 73 kg
		THBC5-4	5,000 lb - 2,270 kg	20,000 lb - 9,075 kg	160 lb / 73 kg
		THBC10-4	10,000 lb - 4,535 kg	40,000 lb - 18,145 kg	240 lb / 109 kg
		THBC20-4	20,000 lb - 9,070 kg	80,000 lb - 36,290 kg	250 lb / 113 kg
	STAINLESS STEEL	THBCS2.5-4	2,500 lb - 1,135 kg	10,000 lb - 4,540 kg	160 lb / 73 kg
		THBCS5-4	5,000 lb - 2,270 kg	20,000 lb - 9,075 kg	160 lb / 73 kg
		THBCS10-4	10,000 lb - 4,535 kg	40,000 lb - 18,145 kg	240 lb / 109 kg
		THBCS20-4	20,000 lb - 9,070 kg	80,000 lb - 36,290 kg	250 lb / 113 kg

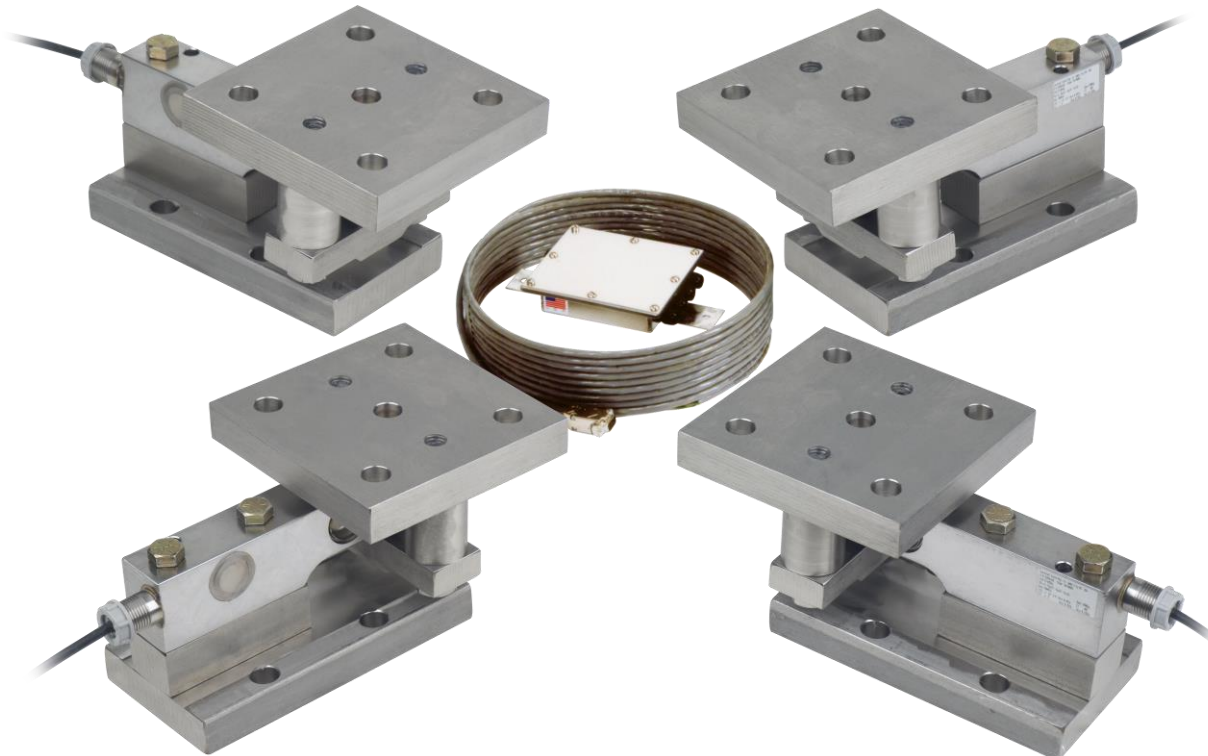

GENERAL INSTALLATION GUIDELINES

The mounting surface for base and top plate must be level, and clear of debris and rough spots. After installation, the top and bottom plates must be level within ± 0.5 degree. If the mounting surfaces are not level, then shims and or grout may be used to level the mount.

1. The mounting surface for base plate and top plate must be level within ± 0.5 degree to minimize side loads and extraneous forces. If the mounting surfaces are not level, then shims or grout may be used to level the module. Because deflections in legs and supporting structures may cause additional side forces that greatly affect accuracy, check if level and plumb again when container is fully loaded. Cross bracing of legs or other support structures may need reinforcement to correct this. Deflections of the module's top or base plate due to loading should not exceed ± 0.5 degree.

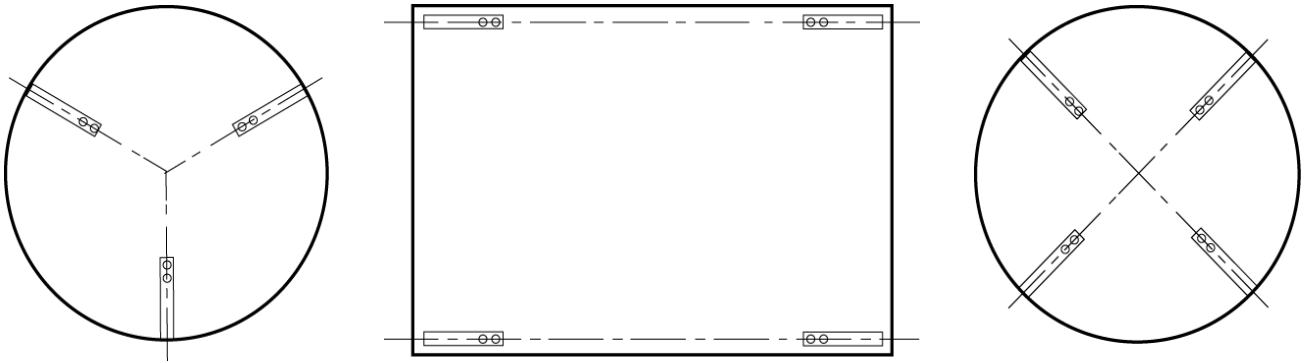

2. Mounting systems use three or four mounts. The load on each mount assembly should vary by no more than 20 percent. Add shims where necessary to achieve correct load distribution.
3. During installation, dummy load cells can be used to prevent overload damage.



NOTE: If the actual load cells are used during the installation, extreme care must be taken to prevent overload damage. A tank or hopper weighing several tons can exert huge forces when dropped only a fraction of an inch.

4. All piping or conduit should be horizontal and flexible. If flexible piping is not used, make sure the distance from tank to the first pipe support is 20-30 times pipe diameter. In smaller, lower capacity tanks and hoppers, isolating resultant forces becomes extremely critical. When possible, flexible conduit piping should be used close to the tank instead of the rigid variety.
5. Load cells should not be installed in the modules until all welding is completed. If possible, use a dummy load cell when welding to maintain finished height. If welding is unavoidable after load cell installation, ground in such a manner as to prevent welding current from passing through the load cell. Ground the welder as closely as possible to the point of welding.

INSTALLATION

The type of installation, structure of the tank supports, and strength of the mounting surface governs the method of locating, attaching, and installing the load cell assembly. Carefully consider three areas that commonly cause accuracy problems:

- Are the supporting legs adequately braced so they will not spread when the system is fully loaded?
 - Does the supporting structure have the necessary strength to prevent flexing when the system is fully loaded?
 - Is there attached equipment such as skirting, venting, or piping which is likely to cause binding or lack of flexibility?
1. Determine where to position the load cell assembly, as well as which direction it should be orientated.
 2. Make necessary preparations to the mounting surfaces.
 3. Lift and block the vessel to the same height as the load cell assembly.
 4. Lift one corner or side of the vessel enough to slide the load cell assembly into place.
 5. If the load cell assembly is being fitted under the leg of the vessel, verify that the leg's centerline passes through the center of the top plate (through the center of the load cell's load hole).
 6. Attach the top plate by bolting. Do not fully tighten because shimming may be necessary to level.
 7. Repeat steps 4, 5, and 6 for the remaining load cell assemblies. The vessel should now be supported on the load cell assemblies alone.
 8. If necessary, move the vessel to its final position. Verify that there is no initial misalignment between the base plate and top plate by lifting the vessel slightly at each support point in turn. This will also indicate if the load is evenly distributed on all load cell assemblies. Install shims if necessary.
 9. Attach the base plates to the foundation using anchor bolts for concrete, or by bolting or welding to a steel structure. Verify that the base plates are no more than ± 0.5 degree out of level. Install shims if necessary.
 10. Check that the top plates are no more than ± 0.5 degree out of level. Shim if necessary and fully tighten the bolts.
 11. The load distribution can be more accurately checked by connecting each load cell to the junction box and indicator and measuring the output with a voltmeter. To verify wiring, check the load cell and junction box wiring section of this manual. The variation in the load among the cells should be no more than 20%. Install shims if necessary.

LOAD CELL WIRING

NOTE: Cardinal Scale Mfg. Co. recommends that the customer install protective conduit/cover for the load cell cables whenever the condition is present that can result in damage or abrasion to the load cell cables.

1. Route the load cell cables so they will not be damaged or cut. Cable should not be routed near heat sources. Do not shorten any load cell cable. The load cell is temperature compensated with the supplied length of cable. Cutting the cable will affect temperature compensation. Coil excess cable and protect it so it will not be damaged or sitting in water.
2. Provide a dip loop in all cables so that water or other liquids will not run directly down the cables onto either the load cells or the junction box. Attach load cell cable to the structure, not the tank.
3. If conduit protection is necessary against mechanical or rodent damage to the load cell cables, use flexible conduit and conduit adapters at the load cells.
4. Connect cables to the summing board in the junction box according to the illustration shown on the next page and the labels on the terminal strips of the junction box. To verify the wiring, refer to the documentation shipped with each load cell.

SB Series Wiring Color Code

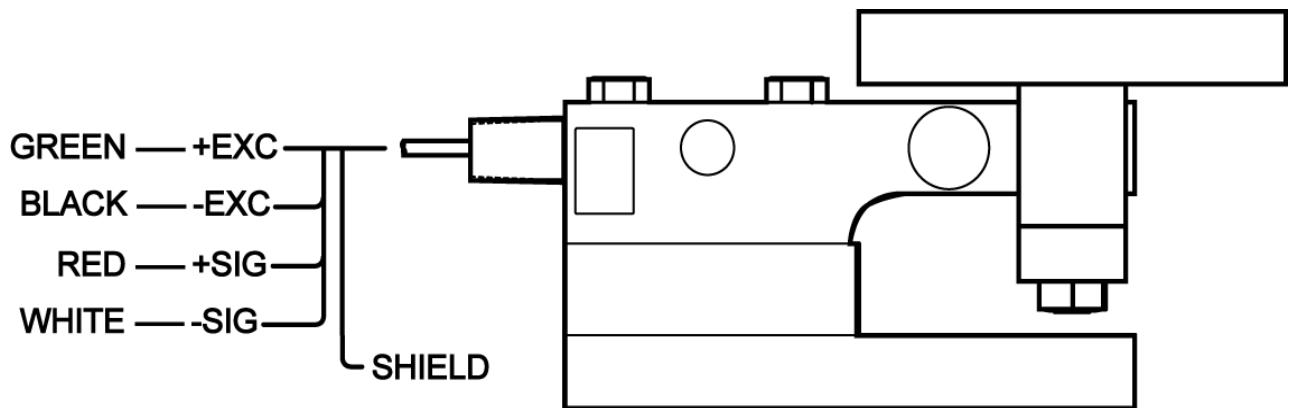

JUNCTION BOX WIRING

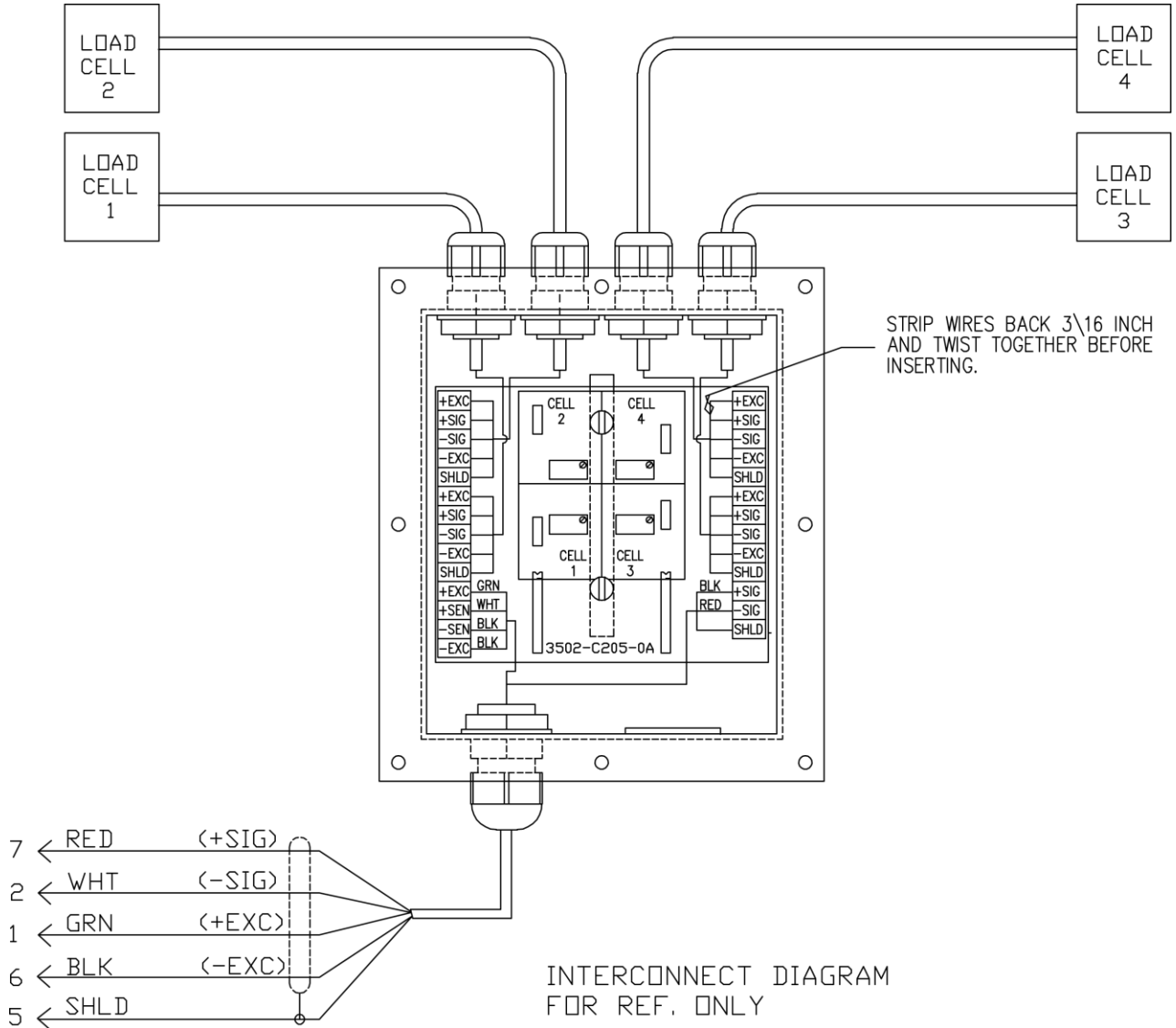

Load Cell Wiring Color Code

FUNCTION	CARDINAL COLOR CODE	WEST COAT COLOR CODE
+EXC	GREEN	RED
-EXC	BLACK	BLACK
+SIG	RED	GREEN
-SIG	WHITE	WHITE

NOTE: For 2 to 4 load cell trimming, connect 2, 3, or 4 load cells to trim board as shown. There are no jumpers that need to be set or additional terminations to be made.

LOAD CELL REPLACEMENT

The following procedure describes changing a load cell. The procedure can also be used when changing a roll pin, rocker washer, load button, or restraint button.

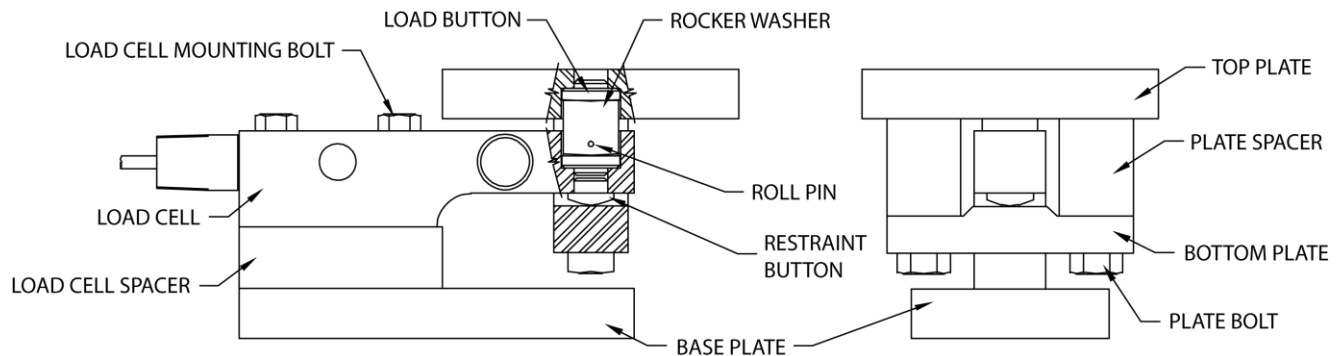

NOTE: The base plate position is shown for use with the 2,500 lb and 10,000 lb load cells. It is turned upside down for use with the 5,000 lb and 20,000 lb load cells.



DANGER! TO PREVENT TIPPING OF THE VESSEL, SUPPORT THE VESSEL WITH BLOCKS OR BY OTHER MEANS TO ENSURE THE STABILITY OF THE VESSEL, BEFORE LIFTING IT OFF THE LOAD CELL ASSEMBLY.

1. Disconnect the load cell from the junction box. Refer to the JUNCTION BOX WIRING sections of this manual for wiring information.
2. Remove the bolts, washers, and nuts securing the top plate to the vessel.
3. **ONLY** if the vessel is empty, using a chain or cable slings, lift and block the vessel to the same height as the load cell assembly to remove the load off the load cell assembly.
NOTE: If emptying the vessel is impractical, it can be raised with external jacks to remove the load off the load cell assembly.
4. Remove the load cell mounting bolts, and then slide the load cell spacer and load cell assembly from under the vessel and away from the base plate.
5. Remove the bolts securing the bottom plate and plate spacers to the top plate.
6. Apply pressure between the load cell and top plate to disengage the load button, and then remove the top plate from the load cell.
7. To reinstall the load cell, position the rocker washer into the load cell. Pass the roll pins through each side of the load cell and press fit into rocker washer until approximately 1/8" (3.2 mm) protrudes from the rocker washer, typically in two places.
8. Position the restraint button in the load cell. Place the load cell and the plate spacers between the top and bottom plates, and then install the bolts securing the bottom plate, load cell, and plate spacers to the top plate.

LOAD CELL REPLACEMENT, CONT.

9. Position the load cell assembly and load cell spacer so it is centered on the base plate, and then fasten in place with the load cell mounting bolts removed earlier.
10. Torque the load cell mounting bolts to the values given in the table below. First, torque the mounting bolt nearest the roll pins, and then torque the mounting bolt at the cable end of the load cell.

NOTE: Insufficient torque may allow the rear of the load cell to lift; too much torque may cause bolt failure.

STAND MODEL	LOAD CELL MODELS	TORQUE
SBCS-NC5 / SBCSS-NC5	SB-2500S / SB-5000S	100 ft/lb
SBCS-NC20 / SBCSS-NC20	SB-10000S / SB-20000S	300 ft/lb

11. Lower the vessel onto the top plate and install bolts, washers, and nuts removed earlier to secure the vessel to the top plate.
12. Reconnect the load cell to the junction box. Refer to the LOAD CELL WIRING and JUNCTION BOX WIRING sections of this manual for wiring information.

PARTS IDENTIFICATION

TOP VIEW

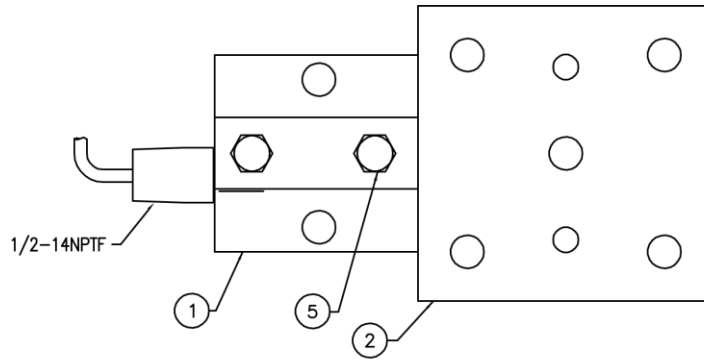

BOTTOM VIEW

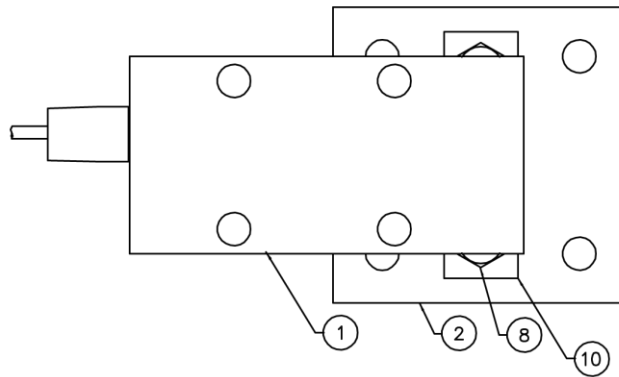

SIDE VIEW

THE LOAD CELL ASSEMBLY IS NOT INCLUDED AND IS SHOWN FOR REFERENCE ONLY.

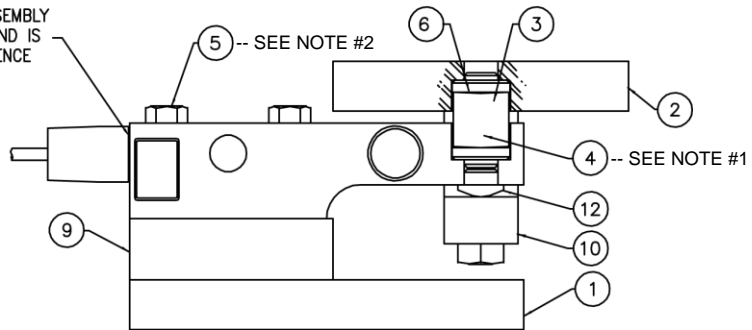

END VIEW

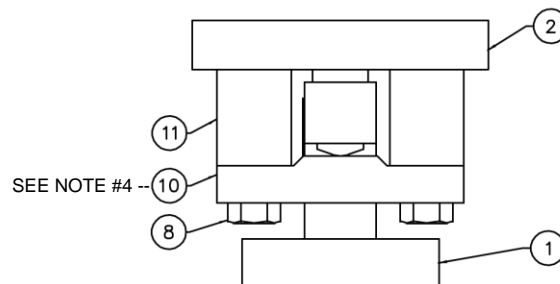

PARTS IDENTIFICATION, CONT.

Notes:

1. Position item #3 into load cell, pass item #4 thru each side of the load cell, and press fit into item # until approximately 1/8" protrudes from item #3.
2. Position the load cell along with items #1 and #9 as shown. Fasten in place using item #5. Apply the specified ft/lb of torque to item #5 during assembly. See chart below.

STAND MODEL	LOAD CELL MODELS	TORQUE
SBCS-NC5 SBCSS-NC5	SB-2500S/SB-5000S	100 ft/lb
SBCS-NC20 SBCSS-NC20	SB-10000S/SB-20000S	300 ft/lb

3. The purchasers of floor stand tank scales are advised to install safety stay rods to prevent tipping of the tank. Cardinal Scale Mfg. Co. will not be responsible for the stability of the tank.
4. Use item #10 in the position shown for use with the 2,500 lb load cell and turn it upside down for use with the 5,000 lb load cell.
5. Use item #10 in the position shown for use with the 10,000 lb load cell and turn it upside down for use with the 20,000 lb load cell.

MILD STEEL STAND

MODEL SBCS-NC5, ASSEMBLY 3500-D051-0A

LOAD CELL MODEL NUMBER, SB2500S/SB-5000S

ITEM	QTY	PART NUMBER	DESCRIPTION
1	1	3500-C052-08	BASE PLATE
2	1	3500-C053-08	TOP PLATE
3	1	3500-B067-08	ROCKER WASHER
4	2	6020-0012	ROLL PINS, 1/8" DIA. X 3/4" LONG 420 SS
5	2	6007-1005	HEX HEAD BOLT, 1/2-20 UNF-2A X 4
6	1	3500-B106-08	LOAD BUTTON
8	2	6007-0240	HEX HEAD BOLT, 5/8-11 UNC-2A X 3 1/2
9	1	3500-B054-08	SPACER
10	1	3500-B055-08	BOTTOM PLATE (SEE NOTE 4)
11	2	3500-B056-08	SPACER
12	1	3500-B057-08	RESTRAINT BUTTON

PARTS IDENTIFICATION, CONT.

MILD STEEL STAND

MODEL SBSCS-NC20, ASSEMBLY 3500-D051-1A

LOAD CELL MODEL NUMBER, SB10000S/SB-20000S

ITEM	QTY	PART NUMBER	DESCRIPTION
1	1	3500-C059-08	BASE PLATE
2	1	3500-C060-08	TOP PLATE
3	1	3500-B067-08	ROCKER WASHER
4	2	6020-0011	ROLL PINS, 1/8" DIA. X 3/4" LONG 420 SS
5	2	6007-1006	HEX HEAD BOLT, 3/4-10 UNC-2A X 5
6	1	3500-B106-08	LOAD BUTTON
8	2	6007-0405	HEX HEAD BOLT, 5/8-11 UNC-2A X 4
9	1	3500-B061-08	SPACER
10	1	3500-B062-08	BOTTOM PLATE (SEE NOTE 5)
11	2	3500-B063-08	SPACER
12	1	3500-B057-08	RESTRAINT BUTTON

STAINLESS STEEL STAND

MODEL SBCSS-NC5, ASSEMBLY 3500-D051-2A

LOAD CELL MODEL NUMBER, SB2500S/SB-5000S

ITEM	QTY	PART NUMBER	DESCRIPTION
1	1	3500-C076-08	BASE PLATE
2	1	3500-C078-08	TOP PLATE
3	1	3500-B067-08	ROCKER WASHER
4	2	6020-0012	ROLL PINS, 1/8" DIA. X 3/4" LONG 420 SS
5	2	6007-1022	HEX HEAD BOLT, 1/2-20 UNF-2A X 4
6	1	3500-B106-08	LOAD BUTTON
8	2	6007-0409	HEX HEAD BOLT, 5/8-11 UNC-2A X 3 1/2
9	1	3500-B080-08	SPACER
10	1	3500-B082-08	BOTTOM PLATE (SEE NOTE 4)
11	2	3500-B085-08	SPACER
12	1	3500-B057-08	RESTRAINT BUTTON

PARTS IDENTIFICATION, CONT.

STAINLESS STEEL STAND

MODEL SBCSS-NC20, ASSEMBLY 3500-D051-2A

LOAD CELL MODEL NUMBER, SB10000S/SB-20000S

ITEM	QTY	PART NUMBER	DESCRIPTION
1	1	3500-C077-08	BASE PLATE
2	1	3500-C079-08	TOP PLATE
3	1	3500-B067-08	ROCKER WASHER
4	2	6020-0011	ROLL PINS, 1/8" DIA. X 3/4" LONG 420 SS
5	2	6007-1023	HEX HEAD BOLT, 3/4-10 UNC-2A X 5
6	1	3500-B106-08	LOAD BUTTON
8	2	6007-0410	HEX HEAD BOLT, 5/8-11 UNC-2A X 4
9	1	3500-B081-08	SPACER
10	1	3500-B083-08	BOTTOM PLATE (SEE NOTE 5)
11	2	3500-B086-08	SPACER
12	1	3500-B057-08	RESTRAINT BUTTON

STATEMENT OF LIMITED WARRANTY

WARRANTY TERMS

Cardinal Scale Manufacturing Company warrants the equipment we manufacture against defects in material and workmanship. The length and terms and conditions of these warranties vary with the type of product and are summarized below:

PRODUCT TYPE	TERM	MATERIAL AND WORKMANSHIP	LIGHTNING DAMAGE See note 9	WATER DAMAGE See note 7	CORROSION See note 4	ON-SITE LABOR	LIMITATIONS AND REQUIREMENTS
WEIGHT INDICATORS	90 DAY REPLACEMENT ----- 1 YEAR PARTS	YES	YES	YES	YES	NO	1, 2, 3, 5, 6 A, B, C, D
LOAD CELLS (Excluding Hydraulic)	1 YEAR	YES	YES	YES	YES	NO	1, 2, 3, 5, 6 A, B, C, D
HYDRAULIC LOAD CELLS (When purchased with Guardian Vehicle Scale)	LIFETIME	YES	YES	YES	YES	90 DAYS	1, 5, 6, 8 A, B, C, D
HYDRAULIC LOAD CELLS (When purchased separately)	10 YEARS	YES	YES	YES	YES	NO	1, 5, 6, 8, 9 A, B, C, D
VEHICLE SCALE (Deck and Below Excl. PSC Series)	5 YEARS	YES	YES	YES	YES	90 DAYS	1, 2, 3, 5, 6 A, B, C, D, E
LSC SCALE (Deck and Below)	3 YEARS	YES	YES	YES	YES	90 DAYS	1, 2, 3, 5, 6, 11 A, B, C, D
GUARDIAN FLOOR SCALES	10 YEARS	YES	YES	YES	YES	NO	1, 2, 3, 5, 6, 9, 10 A, B, C, D
ALL OTHER CARDINAL PRODUCTS	1 YEAR	YES	YES	YES	YES	NO	1, 2, 5, 6 A, B, C, D, E
REPLACEMENT PARTS	90 DAYS	YES	YES	YES	YES	NO	1, 2, 4, 5, 6 A, B, C, D
SWIM AND 760 SERIES VEHICLE SCALES	1 YEAR	YES	YES	YES	YES	90 DAYS	1, 2, 5, 6 A, B, C, D
SOFTWARE	90 DAYS	YES	N/A	N/A	N/A	NO	1, 6 B, C, D
CONVEYOR BELT SCALES (including Belt-Way)	1 YEAR	YES	YES	YES	YES	NO	1, 2, 3, 5, 6 A, B, C, D, E, F



CARDINAL

Ph. (800) 441-4237
E-mail: cardinal@cardet.com
102 E. Daugherty
Webb City, MO 64870

04/24
Printed in USA
315-WARRANTY-CAR-M

APPLICABLE LIMITATIONS AND REQUIREMENTS

1. This warranty applies only to the original purchaser. The warranty does not apply to equipment that has been tampered with, defaced, damaged, or had repairs or modifications not authorized by Cardinal or has had the serial number altered, defaced or removed.
2. This warranty is not applicable to equipment that has not been grounded in accordance with Cardinal's recommendations.
3. This equipment must be installed and continuously maintained by an authorized Cardinal / Belt-Way dealer.
4. Applies only to components constructed from stainless steel.
5. This warranty does not apply to equipment damaged in transit. Claims for such damage must be made with the responsible freight carrier in accordance with freight carrier regulations.
6. Warranty term begins with date of shipment from Cardinal.
7. Only if device is rated NEMA 4 or better or IP equivalent.
8. Lifetime warranty applies to damages resulting from water, lightning, and voltage transients and applies only to the hydraulic load cell structure itself (does not include pressure transducers, rubber seals, o-rings, and associated wiring).
9. 10-Year prorated warranty on hydraulic load cells.
10. 1-Year warranty for scale structure.
11. PSC models' warranty coverage applies only to agricultural installations on farms up to 3,000 acres (LSC models not limited in this manner).
12. Load cell kits MUST be installed in accordance with Cardinal Scale instructions. Failure to follow these instructions will void the warranty.

EXCLUSIONS

- A.) This warranty does not include replacement of consumable or expendable parts. The warranty does not apply to any item that has been damaged due to unusual wear, abuse, improper line voltage, overloading, theft, fire, water, prolonged storage or exposure while in purchaser's possession or acts of God unless otherwise stated herein.
- B.) This warranty does not apply to peripheral equipment not manufactured by Cardinal. This equipment will normally be covered by the equipment manufacturer's warranty.
- C.) This warranty sets forth the extent of our liability for breach of any warranty or deficiency in connection with the sale or use of our product. Cardinal will not be liable for consequential damages of any nature, including but not limited to loss of profit, delays or expenses, whether based on tort or contract. Cardinal reserves the right to incorporate improvements in material and design without notice and is not obligated to incorporate said improvements in equipment previously manufactured.
- D.) This warranty is in lieu of all other warranties expressed or implied including any warranty that extends beyond the description of the product including any warranty of merchantability or fitness for a particular purpose. This warranty covers only those Cardinal products installed in the forty-eight contiguous United States and Canada.
- E.) This warranty does not cover paint coatings due to the variety of environmental conditions.
- F.) Do not cut load cell cables on load cells returned for credit or warranty replacement. Cutting the cable will void the warranty.
- G.) Software is warranted only for performance of the functions listed in the software manual and/or the Cardinal proposal.
- H.) The software warranty does not cover hardware. Warranties on hardware are provided from the hardware vendor only.
- I.) The software warranty does not cover interfacing issues to non-Cardinal supplied hardware.
- J.) The software warranty does not include automatic software upgrades unless purchased separately.



Ph. (800) 441-4237
E-mail: cardinal@cardet.com
102 E. Daugherty
Webb City, MO 64870

04/24
Printed in USA
315-WARRANTY-CAR-M

Cardinal Scale Mfg. Co.

102 E. Daugherty, Webb City, MO 64870 USA

Ph: 417-673-4631 or 1-800-641-2008

Fax: 417-673-2153

www.cardinalscale.com

Technical Support: 1-866-254-8261

E-mail: tech@cardet.com

Printed in USA

3500-0309-0M Rev A 07/18