



CARDINAL®



SB250 SERIES
Remote Display
Installation and Technical Manual

STATIC ELECTRICITY PRECAUTION



CAUTION! This device contains static-sensitive circuit cards and components. Improper handling of these devices or printed circuit cards can result in damage to or destruction of the component or card. Such actual and/or consequential damage IS NOT covered under warranty and is the responsibility of the device owner. Electronic components must be handled only by qualified electronic technicians who follow the guidelines listed below:



ATTENTION! ALWAYS use a properly grounded wrist strap when handling, removing, or installing electronic circuit cards or components. Make certain that the wrist strap ground lead is securely attached to an adequate ground. If you are uncertain of the quality of the ground, you should consult a licensed electrician.

ALWAYS handle printed circuit card assemblies by the outermost edges.
NEVER touch the components, component leads, or connectors.



ALWAYS observe warning labels on static protective bags and packaging and NEVER remove the card or component from the packaging until ready for use.

ALWAYS store and transport electronic printed circuit cards and components in anti-static protective bags or packaging.

FCC COMPLIANCE STATEMENT

WARNING! This equipment generates uses and can radiate radio frequency and if not installed and used in accordance with the instruction manual, may cause interference to radio communications. It has been tested and found to comply with the limits for a Class A computing device pursuant to Subpart J of Part 15 of FCC rules, which are designed to provide reasonable protection against such interference when operated in a commercial environment. Operation of this equipment in a residential area may cause interference in which case the user will be responsible for taking whatever measures necessary to correct the interference.

You may find the booklet "How to Identify and Resolve Radio-TV Interference Problems" prepared by the Federal Communications Commission helpful. It is available from the U.S. Government Printing Office, Washington, D.C. 20402. The stock number is 001-000-00315-4.

COPYRIGHT

All rights reserved. Reproduction or use, without express written permission, of editorial or pictorial content, in any manner, is prohibited. No patent liability is assumed with respect to the use of the information contained herein.

DISCLAIMER

While every precaution has been taken in the preparation of this manual, the Seller assumes no responsibility for errors or omissions. Neither is any liability assumed for damages resulting from the use of the information contained herein. All instructions and diagrams have been checked for accuracy and ease of application; however, success and safety in working with tools depend to a great extent upon individual accuracy, skill, and caution. For this reason, the Seller is not able to guarantee the result of any procedure contained herein. Nor can they assume responsibility for any damage to property or injury to persons occasioned from the procedures. Persons engaging in the procedures do so entirely at their own risk.

INTRODUCTION

Thank you for your purchase of our Cardinal SB250 Series Remote Display. It was built with quality and reliability. This manual will guide you through the installation and operation of your display. Please read it thoroughly before attempting to install your display. Also, make certain that you pay attention to the warnings that appear in this manual. Failure to read and follow these instructions and warnings may result in damage to the display and/or bodily injury. Please keep this manual handy for future reference.

SPECIFICATIONS

Character Height:	2.6 inch (6.6 cm)
Viewing Range:	200 Feet
Viewing Angle:	Viewable in direct sunlight with an angle of +/- 70 degrees
Number of Characters:	9 Alpha Numeric (5 x 7 Matrix with Descenders and Decimal Point)
Display Type:	High-Intensity LED
Annunciators:	lb, kg, T, t, G, N
Enclosure Type:	Mild Steel, Painted with an IP-55 rating
Dimensions:	24.7 W x 5.5 D x 9.6 H (12.6 w/mounting flanges)
Weight:	16 lbs
Data Input:	RS-232, RS-422, RS-485 and 20ma Current Loop
Power Requirements:	85 to 270 VAC, 47/63 Hz Universal Input
Power Fuse	2A @ 115VAC, 1A @ 230VAC
Operating Temperature:	-10 to 120 °F (-23 to 49 °C)

SPECIAL FEATURES

- Auto-Learn feature (automatically selects input protocol).
- Custom configuration via serial port and Cardinal software.
- Alpha descriptors for units (no more stats lamps required).
- 10 Levels of brightness.
- On-board intensity sensor automatically adjusts to ambient light.
- The SB250 can scroll and display messages from a programmable indicator or PC application.

INSTRUMENT COMPATIBILITY

Utilizing the Auto-Learn feature, the SB250 display can be driven by the following Cardinal weight indicators and most other weight indicators from other manufacturers. Should configuration be required, Cardinal provides the Smart Configuration software for serial updating of the display.

Current Models:

185/185B, 190/190A, 204, 200, 212/212X, and 825
205, 210, 210FE, 212G/212GX, 225 (with USB)

Legacy Models

180, 204S, 215, 220, 777 Series, 778 Series and 788 Series
Non-USB 205, 210, 210FE, 212/212X, 212G/212GX, 225

AUTO-LEARN FEATURE

The display interface can auto-learn most serial protocols (automatically selects input protocol). The interface auto detects baud rates between 2400 and 19200 baud with the following settings.

Baud rate	2400 to 19200
Data bits	7 or 8
Parity	Odd, Even, or No parity
Character format	all standard ASCII characters

One user protocol can be entered into the display using the serial port and Cardinal software.

MULTIPLE DISPLAYS

The SB250 display has been designed to be linked or daisy-chained to other SB250 displays allowing multiple lines of weight data to be displayed while being driven by a single serial port on the weight indicating instrument. Typical applications might consist of three displays showing Gross, Net, and Tare weights from a single indicator or four displays showing the weight from each of three platforms and a total weight also from a single weight indicator. Special application software is required in the indicator for multiple displays and is not part of the SB250 display.

SITE PREPARATION

Electrical Power

The SB250 display has been designed to operate from 85 to 270 VAC at 47/63 Hz. Note that a special order is not required for operation at 230 VAC.



CAUTION! - To avoid electrical hazards and possible damage to the display, DO NOT, under any circumstance, cut, remove, alter, or in any way bypass the power cord grounding prong.

- The power for the display should be on a separate circuit from the distribution panel. This circuit should be dedicated to the exclusive use of the display.
- The wiring should conform to national and local electrical codes and ordinances and should be approved by the local inspector to ensure compliance.
- For permanently connected equipment, a readily accessible disconnect device must be provided external to the equipment.
- For pluggable equipment, the socket outlet shall be installed near the equipment and shall be easily accessible
- **It is the responsibility of the customer** to have a qualified electrician install the proper service disconnect that conforms to national electrical codes and local codes and ordinances.
- On models requiring 230 VAC power, **it is the responsibility of the customer** to have a qualified electrician install the proper power cord plug that conforms to national electrical codes and local codes and ordinances.

Electrical Noise Interference

To prevent electrical noise interference, make certain all other wall outlets for use with air conditioning and heating equipment, lighting or other equipment with heavily inductive loads, such as welders, motors, and solenoids are on circuits separate from the display. Many of these disturbances originate within the building itself and can seriously affect the operation of the display. These sources of disturbances must be identified and steps must be taken to prevent possible adverse effects on the display. Examples of available alternatives include isolation transformers, power regulators, uninterruptible power supplies, or simple line filters.

INSTALLATION

Unpacking

Before beginning installation of your SB250 display, make certain it has been received in good condition. Carefully remove the display from the shipping carton and inspect it for any evidence of damage (such as exterior dents or scratches) that may have taken place during shipment. Keep the carton and packing material for return shipment if it should become necessary. **NOTE:** It is the responsibility of the purchaser to file all claims for any damages or loss incurred during transit.

SB250 Dimensions

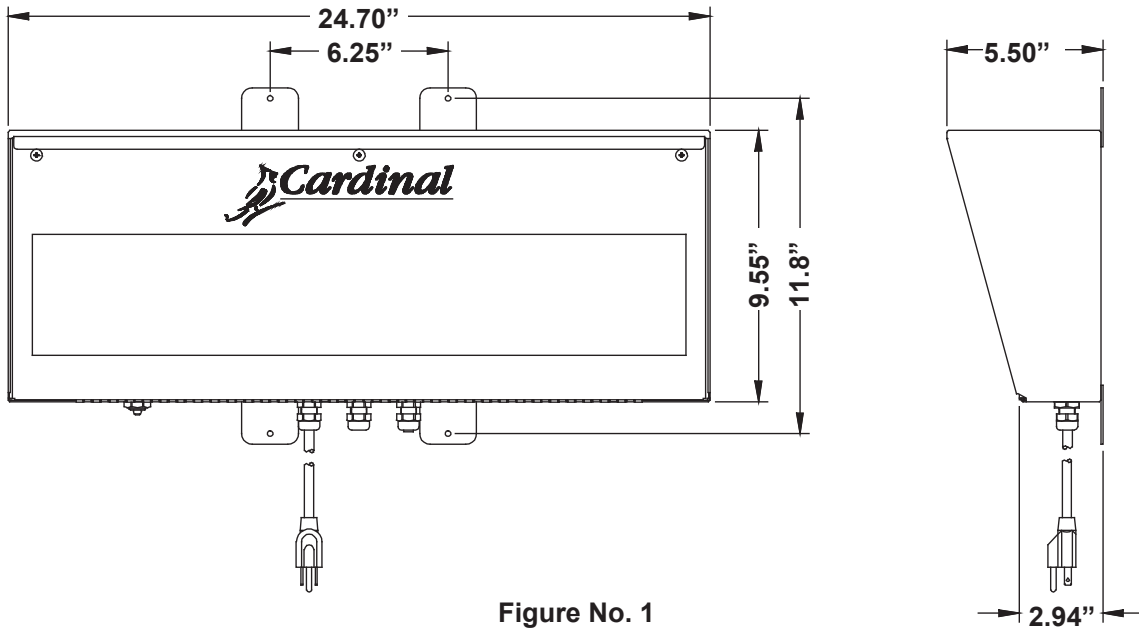

Mounting

The SB250 display is normally mounted on a wall or some other vertical surface. The display is attached to the wall with four (4) bolts. Refer to Figure No. 1 for the mounting hole layout.

First, make sure the mounting surface is strong enough to support the display. Carefully lay out the mounting hole locations, then drill and install the anchor bolts. Attach the display to the wall and securely tighten the retaining bolts.

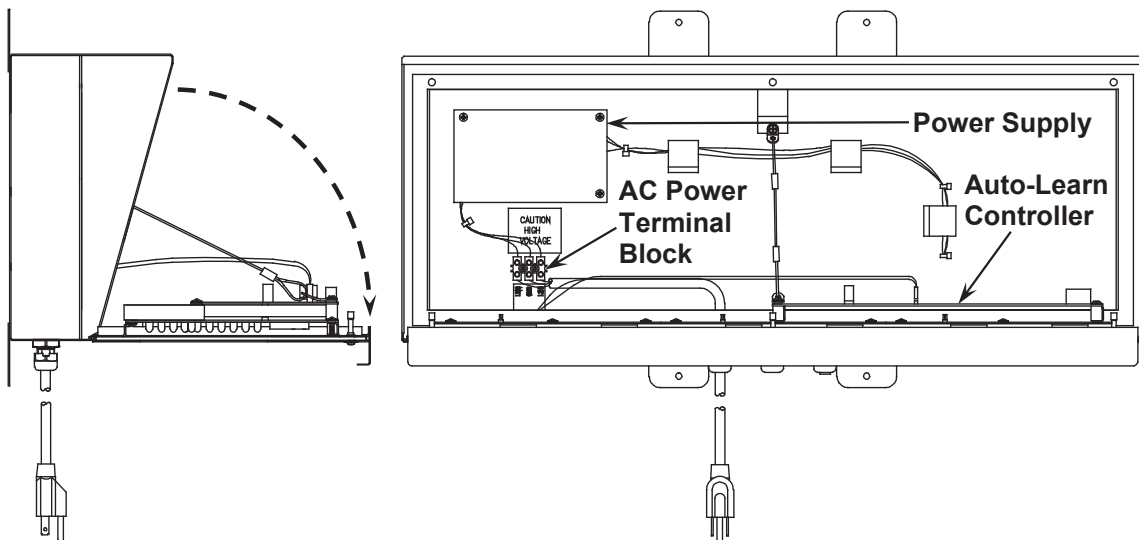

INSTALLATION, CONT.

Continue by lowering the front panel on the display enclosure. Remove all four retaining screws and set aside. Fully lower the front panel of the display exposing the internal circuit boards mounted to the panel and the AC power terminal block and power supply mounted inside the enclosure. See Figure No. 2.

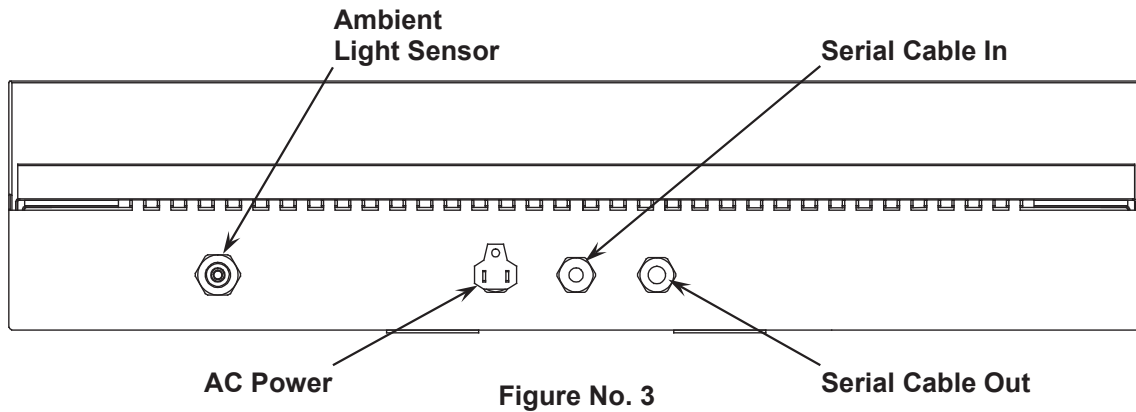

AC POWER CONNECTION

1. Referring to Figure No. 3 for an illustration of the gland connectors, bring the AC power into the enclosure.
2. With the AC wiring in the enclosure, remove approximately one-half inch of insulation from each conductor.
3. To connect each wire to the AC power terminal block, first, loosen each of the three screw terminals then insert each wire into the proper terminal and securely tighten the screws. Refer to the wiring color code table below, Figure No. 4, and the labels in the display enclosure for the correct terminal connections.



IMPORTANT! Use 18 to 20 AWG copper wire to connect the AC power to the display.

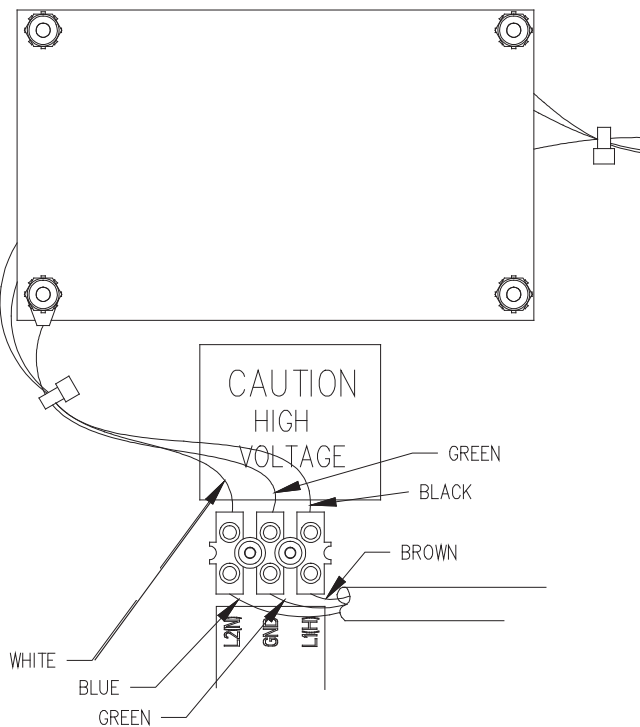

Figure No. 4

115VAC WIRING COLOR CODE TABLE

Function	U.S. Code	International Code
L1 (H) - Hot	Black	Brown
L2 (N) - Neutral	White	Blue
GND - Ground	Green	Green/Yellow

AUTO-LEARN CONTROLLER BOARD

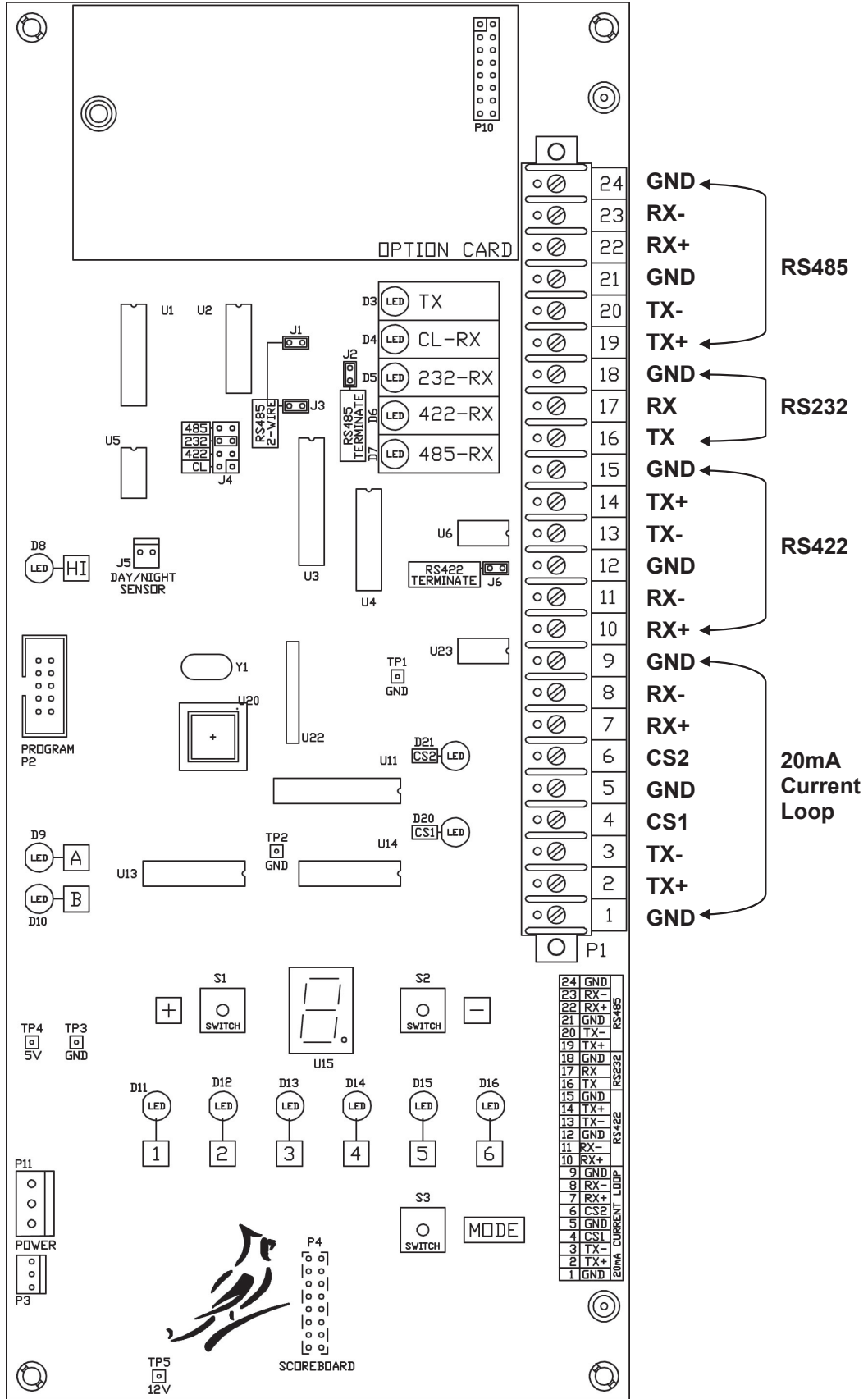

Figure No. 5

AUTO-LEARN CONTROLLER BOARD

STATUS LED'S AND DISPLAY

- D3** = In a multi display daisy-chained configuration, D3 flashes when the display is sending data to the next display in the chain.
- D4** = Turned on to indicate display is receiving using the 20mA current loop serial protocol.
- D5** = Turned on to indicate display is receiving using the RS232 serial protocol.
- D6** = Turned on to indicate display is receiving using the RS422 serial protocol.
- D7** = Turned on to indicate display is receiving using the RS485 serial protocol.
- D8** = Turned on to indicate display is operating in the day mode. D8 is turned off when the display is operating in the night mode.
- D9** = Not used at this time.
- D10** = Not used at this time.
- D11 to 16** = (1 to 6) Turned on to show the current setup parameter.
- U15** = A 1-digit seven-segment LED.

In the Setup mode, U15 is used to show the current value of the setup parameter indicated by which LED, D11 to 16 (1 to 6) is turned on.

When the display is running, U15 is used to indicate the baud rate number the controller is using. Refer to the table below.

U15 Baud Rate Table

1 = 2400	2 = 4800	3 = 9600	4 = 19,200
----------	----------	----------	------------

JUMPERS

- J1** = RS485 2-wire or 4-wire selection. ON = 2-wire (half duplex), OFF = 4-wire (full duplex).
- J2** = RS485 termination selection. ON = terminate, OFF = unterminated.
NOTE: The last display on the RS485 bus must have terminating jumpers installed, and the displays in the middle of the bus must have terminating jumpers removed.
- J3** = RS485 2-wire or 4-wire selection. ON = 2-wire (half duplex), OFF = 4-wire (full duplex).
- J4** = Receive mode selection jumper.
- J5** = Two-pin connector for the day/night sensor.
- J6** = RS422 termination selection. ON = terminate, OFF = unterminated.
NOTE: The last display on the RS422 bus must have terminating jumpers installed, and the display in the middle of the bus must have terminating jumpers removed.

CONNECTORS

- P1** = 24 terminal connector for serial cable connections. Refer to Figure No. 5.
- P2** = Program (In System Programming) connector
- P3** or **P11** = Power connector
- P4** = Test Header (*For Factory Use Only*)

SWITCHES

- S1** = (+) Used during programming to increment to the next parameter value.
- S2** = (-) Used during programming to decrement to the previous parameter value.
- S3** = (MODE) Press to begin Setup and Configuration mode. During setup, press to advance to the next setup parameter.

SERIAL CABLE INSTALLATION

RS232

1. Loosen the cable gland connector for the serial cable. The gland connector for the serial cable is located on the bottom of the enclosure. Refer to Figure No. 3 for an illustration of the gland connector layout.
2. Slip the serial cable through the gland connector and into the enclosure.
3. Remove 2" of the outer insulation jacket from the cable then remove 1/2" of insulation from each of the wires.
4. Referring to Figure No. 5 for the location of the terminal block and for the correct terminal connections, connect each of the wires to the terminal block.
5. To connect each wire to the terminal block, first loosen each of the screw terminals then insert the wire under the terminal washer. Tighten the screw to secure the wire in place.
6. Install the Receive mode jumper J4, ON the 232 pins.

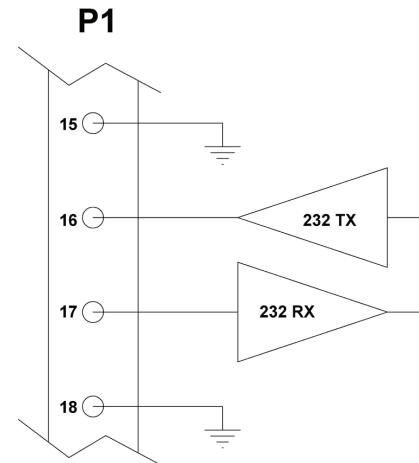

Figure No. 6

RS422

1. Loosen the cable gland connector for the serial cable. The gland connector for the serial cable is located on the bottom of the enclosure. Refer to Figure No. 3 for an illustration of the gland connector layout.
2. Slip the serial cable through the gland connector and into the enclosure.
3. Remove 2" of the outer insulation jacket from the cable then remove 1/2" of insulation from each of the wires.
4. Referring to Figure No. 5 for the location of the terminal block and for the correct terminal connections, connect each of the wires to the terminal block.
5. To connect each wire to the terminal block, first loosen each of the screw terminals then insert the wire under the terminal washer. Tighten the screw to secure the wire in place.
6. Ensure that the termination jumper J6 is set correctly. It must be ON for termination or OFF for unterminated operation.
7. Install the Receive mode jumper J4, ON the 422 pins.

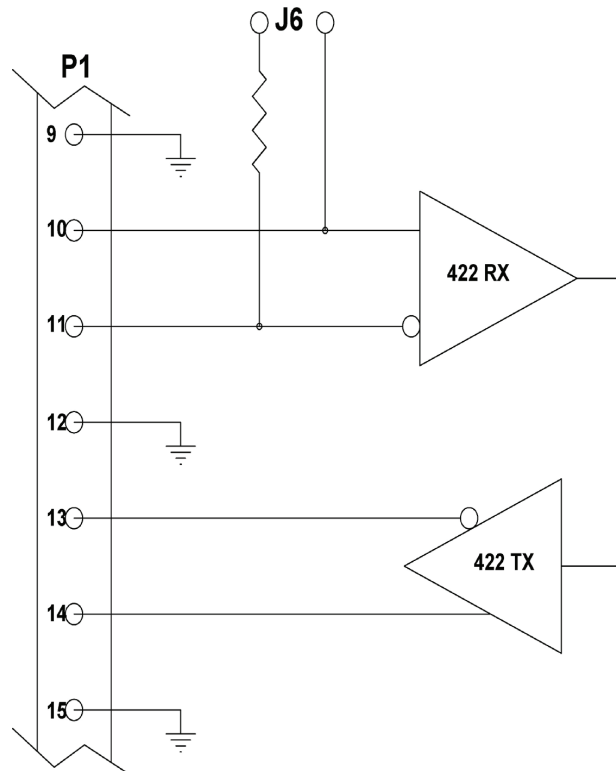
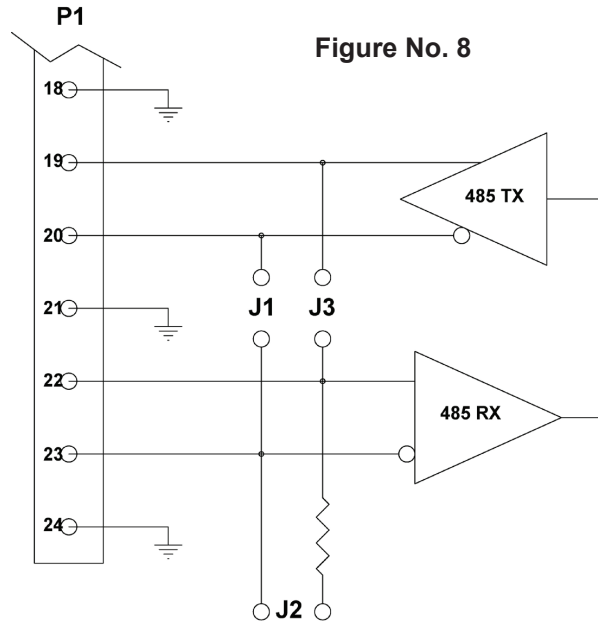

Figure No. 7

SERIAL CABLE INSTALLATION, CONT.

RS485

- Loosen the cable gland connector for the serial cable. The gland connector for the serial cable is located on the bottom of the enclosure. Refer to Figure No. 3 for an illustration of the gland connector layout.
- Slip the serial cable through the gland connector and into the enclosure.
- Remove 2" of the outer insulation jacket from the cable then remove 1/2" of insulation from each of the wires.
- Referring to Figure No. 5 for the location of the terminal block and for the correct terminal connections, connect each of the wires to the terminal block.
- To connect each wire to the terminal block, first loosen each of the screw terminals then insert the wire under the terminal washer. Tighten the screw to secure the wire in place.
- Ensure that the termination jumper J2 is set correctly. It must be ON for termination or OFF for un-terminated operation.
- Ensure that the 2-wire or 4-wire selection jumpers J1 and J3 are set correctly. Both jumpers must be ON for 2-wire operation or both must be OFF for 4-wire operation.
- Install the Receive mode jumper J4, on the 485 pins.



20mA Current Loop

- Loosen the cable gland connector for the serial cable. The gland connector for the serial cable is located on the bottom of the enclosure. Refer to Figure No. 3 for an illustration of the gland connector layout.
- Slip the serial cable through the gland connector and into the enclosure.
- Remove 2" of the outer insulation jacket from the cable then remove 1/2" of insulation from each of the wires.
- Referring to Figure No. 5 for the location of the terminal block and for the correct terminal connections, connect each of the wires to the terminal block.
- To connect each wire to the terminal block, first loosen each of the screw terminals then insert the wire under the terminal washer. Tighten the screw to secure the wire in place.
- Install the Receive mode jumper J4, ON the CL pins.

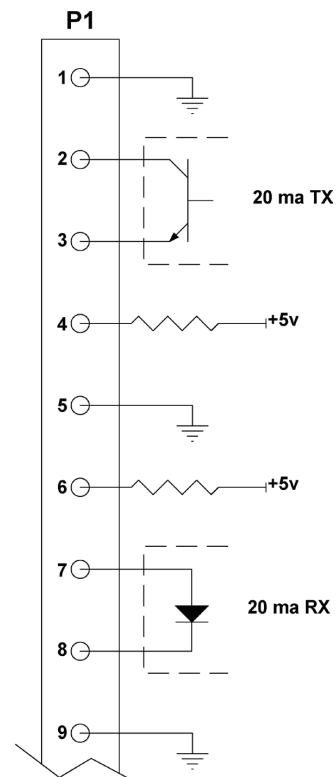

Figure No. 9

SERIAL CABLE INSTALLATION, CONT.

CURRENT Cardinal Indicators 20mA Current Loop Connections

190/190A (with 190-RS232 Option Card)

CARD (PASSIVE)	SB250
P4,6	P1, 8
P4,7	P1, 9
n/c	JUMPER P1, 6 to P1, 7

200

PORT 1	SB250
P3, 3	P1, 7
P3, 4	P1, 8

PORT 2	SB250
P3, 6	P1, 7
P3, 7	P1, 8

205, 210, 210FE and 215

PORT 1	SB250
P11, 3	P1, 7
P11, 4	P1, 8

PORT 2	SB250
P11, 6	P1, 7
P11, 7	P1, 8

225

PORT 1 (ACTIVE)	SB250
P14, 3	P1, 7
P14, 4	P1, 8
JUMPER P14, 5 to P14, 8	n/c

PORT 1 (PASSIVE)	SB250
P14, 4	P1, 8
P14, 5	P1, 9
n/c	JUMPER P1, 6 to P1, 7

PORT 2 (ACTIVE)	SB250
P18, 1	P1, 7
P18, 2	P1, 8
JUMPER P18, 3 to P18, 9	n/c

PORT 2 (PASSIVE)	SB250
P18, 2	P1, 8
P18, 3	P1, 9
n/c	JUMPER P1, 6 to P1, 7

PORT 3 (ACTIVE)	SB250
P18, 12	P1, 7
P18, 13	P1, 8

825

PORT 2 (ACTIVE)	SB250
P21, 2	P1, 7
P21, 5	P1, 8
J3 INSTALLED J7 SHUNT:20mA	n/c

PORT 2 (PASSIVE)	SB250
P21, 1	P1, 8
P21, 2	P1, 9
J3 REMOVED J7 SHUNT:20mA	JUMPER P1, 6 to P1, 7

SERIAL CABLE INSTALLATION, CONT.

LEGACY Cardinal Indicators 20mA Current Loop Connections

205, 210, 210FE, 212/212X, 212G/212GX (without USB)

PORT 1	SB250
P11, 3	P1, 7
P11, 4	P1, 8

PORT 2	SB250
P11, 6	P1, 7
P11, 7	P1, 8

215

PORT 1	SB250
P11, 3	P1, 7
P11, 4	P1, 8

PORT 2	SB250
P11, 6	P1, 7
P11, 7	P1, 8

220

220 PORT 1 (ACTIVE)	SB250
P10, 1	P1, 7
P10, 2	P1, 8
JUMPER P10, 3 to P10, 10	n/c

220 PORT 1 (PASSIVE)	SB250
P10, 2	P1, 8
P10, 3	P1, 9
n/c	JUMPER P1, 6 to P1, 7

220 PORT 2	SB250
P10, 11	P1, 7
P10, 10	P1, 8

225 (without USB)

PORT 1 (ACTIVE)	SB250
P14, 3	P1, 7
P14, 4	P1, 8
JUMPER P14, 5 to P14, 8	n/c

PORT 1 (PASSIVE)	SB250
P14, 4	P1, 8
P14, 5	P1, 9
n/c	JUMPER P1, 6 to P1, 7

PORT 2 (ACTIVE)	SB250
P18, 1	P1, 7
P18, 2	P1, 8
JUMPER P18, 3 to P18, 9	n/c

PORT 2 (PASSIVE)	SB250
P18, 2	P1, 8
P18, 3	P1, 9
n/c	JUMPER P1, 6 to P1, 7

PORT 3 (ACTIVE)	SB250
P18, 12	P1, 7
P18, 13	P1, 8

778C

778C (PASSIVE)	SB250
COMA, 11	P1, 8
COMA, 23	P1, 9
n/c	JUMPER P1, 6 to P1, 7

778C (ACTIVE)	SB250
COMA, 10	P1, 7
COMA, 11	P1, 8
JUMPER COMA, 23 to COMA, 24	n/c

MULTIPLE DISPLAY CONNECTIONS

Figure No. 10 illustrates a typical RS-232 installation consisting of four displays to show the weight from each of the three platforms and a total weight driven by a single serial port on the weight indicating instrument.

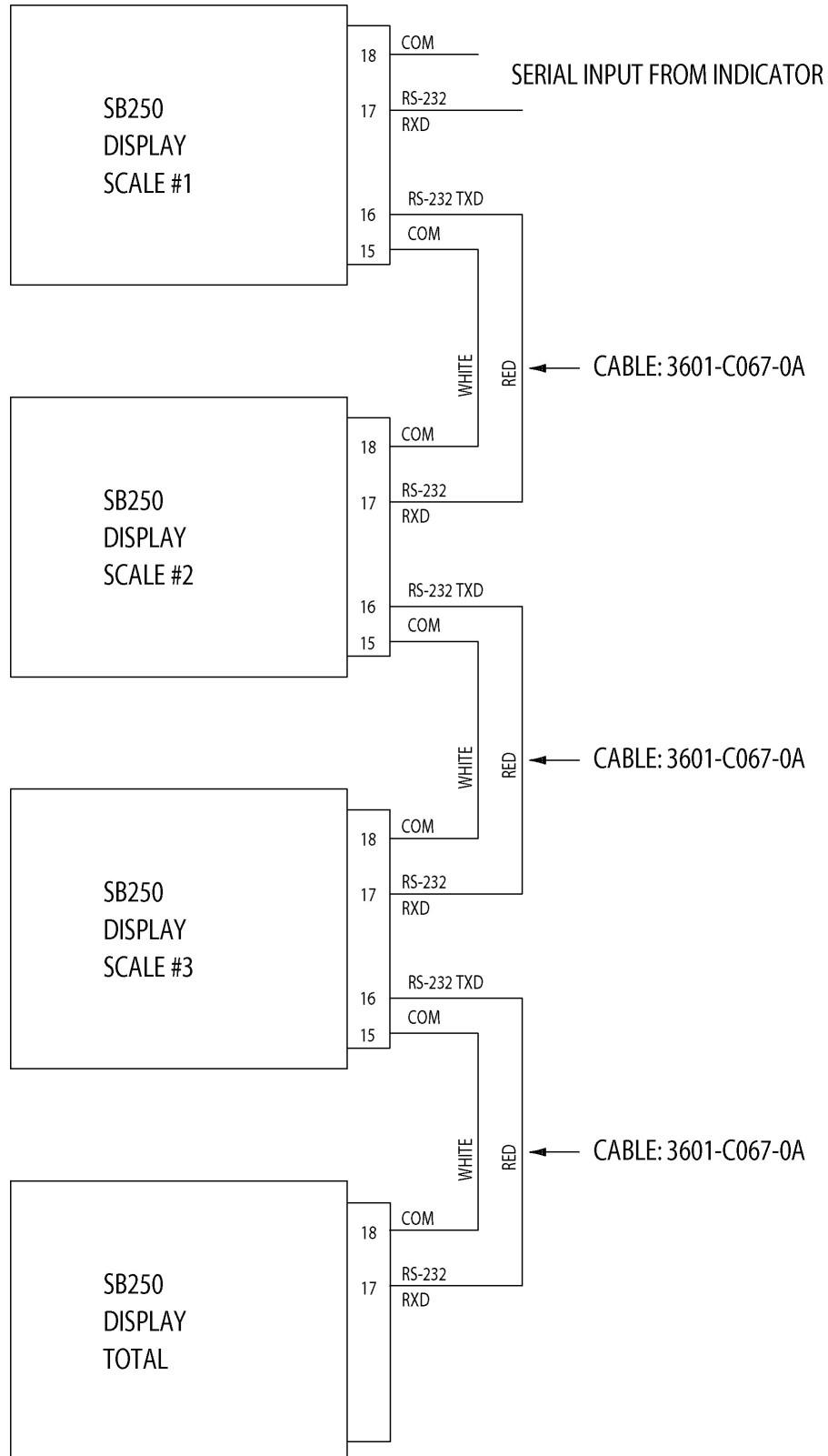

Figure No. 10

SETUP AND CONFIGURATION

The SB250 display has been pre-configured at the factory and should not require configuration for use in most applications. If the factory settings do not meet the requirements of your application, the following describes the steps to configure the display.

The setup mode switch is located on the front right side of the Auto Learn Controller board. You may gain access to this switch by removing the four screws and lowering the front panel on the enclosure. The setup mode switch is identified in Figure No. 5. Once you have located the setup mode switch proceed with the setup instructions.



NOTE: The display must be in the normal operating mode (after auto-detect has completed) and/or after displaying the software revision, pausing, and then displaying the model number to enter the setup mode.

To enter the setup mode, with the display ON, press and release the setup mode switch. The first LED (1) will turn on and the 7-segment LED (U15) will show the current value. Note that the front display will also show the current setup parameter and its value.

LED 1 (1 on Remote Display)

STANDARD INTENSITY SETTING

The 7-segment LED (U15) and the scoreboard will show the current value. If the setting displayed is acceptable, press the **MODE** switch to save it and advance to the next setup parameter. Otherwise, using the (+) switch to increase the value or the (-) switch to decrease the value, select the new setting, then press the **MODE** switch to save it and advance to the next setup parameter. Values from 0 to 9 may be selected.

0 = Dim 9 = Bright

LED 2 (2 on Remote Display)

LOW LIGHT INTENSITY SETTING

The 7-segment LED (U15) and the scoreboard will show the current value. If the setting displayed is acceptable, press the **MODE** switch to save it and advance to the next setup parameter. Otherwise, using the (+) switch to increase the value or the (-) switch to decrease the value, select the new setting, then press the **MODE** switch to save it and advance to the next setup parameter. Values from 0 to 9 may be selected.

0 = Dim 9 = Bright

SETUP AND CONFIGURATION, CONT.

LED 3 (A on Remote Display)

RS485 ADDRESS

The 7-segment LED (U15) and the scoreboard will show the current value. If the setting displayed is acceptable, press the **MODE** switch to save it and advance to the next setup parameter. Otherwise, using the (+) switch to increase the value or the (-) switch to decrease the value, select the new setting, then press the **MODE** switch to save it and advance to the next setup parameter. Values from 0 to F may be selected.



NOTE: When using the RS485 protocol, data is only displayed if the correct address is detected.

The data format for the RS485 serial input is:

%ADDDDDDDDD<CR>

Where:

A = address byte

D = byte of data for display (at least 9 bytes, decimal points and commas are considered part of the preceding digit and may be inserted at any location)

<CR> = carriage return

NOTES:

- The weight/units/mode information must be correctly positioned; no translation is performed on the data sent.
- If the address is set to 0 (zero), the RS485 operation is disabled and the scoreboard will default to daisy chain operation if the RS485 protocol is used.
- In the daisy chain operation, if the address is greater than 0, the scoreboard will decrement the address and send the data out of the serial port to another daisy-chained scoreboard.

SETUP AND CONFIGURATION, CONT.

LED 4 (S on Remote Display)

MODE OF OPERATION

The 7-segment LED (U15) and the scoreboard will show the current value. If the setting displayed is acceptable, press the **MODE** switch to save it and advance to the next setup parameter. Otherwise, using the (+) switch to increase the value or the (-) switch to decrease the value, select the new setting, then press the **MODE** switch to save it and advance to the next setup parameter. Values from 0 to 2 may be selected.

0 = Message-board format (DEFAULT)

1 = Normal scoreboard format

2 = Scoreboard mode with no timeout.

If Mode of Operation = 0, the data format for the serial input to the message board is:

%NDDDDDDDDDD<CR>

where: N = Panel number for a daisy chain configuration
D = Byte of data to display at respective location on the scoreboard
<CR> = Carriage Return

If Mode of Operation = 1 or 2, the data format for the serial input to the scoreboard is:

%NDDDDDDUUMT<CR>

where: N = Panel number for a daisy chain configuration
D = Byte of data to display at respective location on the scoreboard
UU = Units (lb, kg, T, t)
M = Mode (G = Gross or N = Net)
T = Control character for the traffic light.

Valid characters for T are:

G or g or C	=	Green Circle. (Notice: Capital letter for Green except for g)
R or r or c	=	Red Circle. (Lower case letter for red except for r)
S	=	Down green arrow (Green South)
s	=	Down red arrow (Red South)
N	=	Up green arrow (Green North)
n	=	Up red arrow (Red North)
W/w	=	Left arrow (Green/Red)
E/e	=	Right arrow (Green/red)
A	=	1 st user image*
D	=	2 nd user image*
F	=	3 rd user image*
H	=	4 th user image*
I	=	5 th user image*
J	=	6 th user image*
K	=	7 th user image*
L	=	8 th user image*
" "	=	(space) = no lights on

<CR> = Carriage Return

* The SB250 scoreboard (with rectangle display image) together with SBImaging software allows the user to design up to 8 configurable images to display on the scoreboard.

SETUP AND CONFIGURATION, CONT.

LED 5 (B on Remote Display)

BAUD SELECTION

The 7-segment LED (U15) and the scoreboard will show the current value. If the setting displayed is acceptable, press the **MODE** switch to save it and advance to the next setup parameter. Otherwise, using the (+) switch to increase the value or the (-) switch to decrease the value, select the new setting, then press the **MODE** switch to save it and advance to the next setup parameter. Values from 0 to 5 may be selected.

0 = Auto Detect *	1 = 2400	2 = 4800
3 = 9600	4 = 19,200	* Factory Default

LED 6 (P on Remote Display)

SERIAL DATA FORMAT (for transmit only)

The 7-segment LED (U15) and the scoreboard will show the current value. If the setting displayed is acceptable, press the **MODE** switch to save it and advance to the next setup parameter. Otherwise, use the (+) switch to increase the value or the (-) switch to decrease the value, select the new setting, and then press the **MODE** switch to save it and complete setup and configuration. Values from 0 to 2 may be selected.

- 0 = 7 data, even parity, 1 stop bit (7, E, 1)
- 1 = 7 data, odd parity, 1 stop bit (7, O, 1)
- 2 = 8 data, no parity, 1 stop bit (8, N, 1)



NOTE: If the Baud Selection is set for Auto Detect, the data format is automatically detected from one of the above formats.

LED A (SO= on Remote Display)

SWITCHED OPERATION MESSAGE SETTING

The SO = setting enables switched operation utilizing a customer supplied remote toggle switch and does not require serial input to display the message pairs below. The messages are driven from the current-loop input on the terminal block. Note that when SO= is enabled (set to 1 to 9), the serial input to the SB250M is disabled. Also, note that the factory default value is 0 (serial input is enabled).

The 7-segment LED (U15) and the scoreboard will show the current value. If the setting displayed is acceptable, press the **MODE** switch to save it and advance to the next setup parameter. Otherwise, using the (+) switch to increase the value or the (-) switch to decrease the value, select the new setting, then press the **MODE** switch to save it and advance to the next setup parameter. Values from 0 to 9 may be selected.

0 = DISABLED (Serial Input is Enabled)*	5 = WALK	WAIT	
1 = OPEN	CLOSED	6 = LEFT	RIGHT
2 = GO	STOP	7 = UP	DOWN
3 = ON	OFF	8 = ENTER	EXIT
4 = START	STOP	9 = SPACES ()	ASTERISKS (***)

* Factory Default



To use the switched operation, the Receive Mode jumper J4 must be ON the CL pins. In addition, on the P1 terminal connector, jumper terminals 6 and 7 together and then connect the operation toggle switch across terminals 8 and 9. Refer to Figure No. 4 for the location of J4, P1, and the connection descriptions.

SETUP AND CONFIGURATION, CONT.

LED B (SP= on Remote Display)

SUPPRESS LEADING ZEROS

The 7-segment LED (U15) and the scoreboard will show the current value. If the setting displayed is acceptable, press the **MODE** switch to save it and advance to the next setup parameter. Otherwise, using the (+) switch to increase the value or the (-) switch to decrease the value, select the new setting, then press the **MODE** switch to save it and advance to the next setup parameter. Values of 0 or 1 may be selected

0 = No suppression (DEFAULT) 1 = Suppress zeros

LED A and B (SD= on Remote Display)

SUPPRESS DECIMAL POINT AT LOCATION 0 (ZERO)

The 7-segment LED (U15) and the scoreboard will show the current value. If the setting displayed is acceptable, press the **MODE** switch to save it and advance to the next setup parameter. Otherwise, using the (+) switch to increase the value or the (-) switch to decrease the value, select the new setting, then press the **MODE** switch to save it and advance to the next setup parameter. Values of 0 or 1 may be selected

0 = Allows a decimal point after the least significant digit of weight

1 = Prevents a decimal point from displaying to the right of the least significant byte of weight (DEFAULT)

LED A, B, and 1 (SA= on Remote Display)

SUPPRESS THE ANNUNCIATOR INFORMATION

The 7-segment LED (U15) and the scoreboard will show the current value. If the setting displayed is acceptable, press the **MODE** switch to save it and advance to the next setup parameter. Otherwise, using the (+) switch to increase the value or the (-) switch to decrease the value, select the new setting, then press the **MODE** switch to save it and advance to the next setup parameter. Values of 0 or 1 may be selected

0 = No suppression. The annunciator information is displayed (DEFAULT)

1 = Suppress the annunciator display

SETUP AND CONFIGURATION, CONT.

LED 1, 2, A and B (SF= on Remote Display)

SERIAL FORMAT

The SF = setting allows setup to override the Auto-Learn serial format feature. To select a format manually, set SF= to a number listed below. Note that the factory default value is 0 (Auto-Learn is enabled).

The 7-segment LED (U15) and the scoreboard will show the current value. If the setting displayed is acceptable, press the **MODE** switch to save it and advance to the next setup parameter. Otherwise, using the (+) switch to increase the value or the (-) switch to decrease the value, select the new setting, then press the **MODE** switch to save it and advance to the next setup parameter. Values from 0 to 9 and A may be selected.

0 = Auto-Learn¹	6 = SMA
1 = SB400 with Decimal Point	7 = WI110
2 = SB400 without Decimal Point	8 = Airborne
3 = SB200	9 = Fairbank²
4 = Computer	A = Toledo³
5 = IQ355	

¹ Utilizing the Auto-Learn feature, the SB250 display can be driven by most weight indicators. Refer to the INSTRUMENT COMPATIBILITY section of this manual.

² Format: <STX><Status1><Status0><Sign><XXXXXX><ETX>

NOTE: <Status1><Status0> will be ignored. The SB250 will only display weight values and negative values.

³ When operating with Toledo format, users must make sure there is NO checksum, NO Tare weight and there must be Start and Stop characters for the string (since Toledo indicators allow adjustments on those requirements).

LED 1, 2, 3, 4, A AND B (RI= on Remote Display)

MIRROR IMAGE

The RI= setting allows the user to specify how many seconds the scoreboard will remain the same until switching back and forth between normal display and mirror image display.

The 7-segment LED (U15) and the scoreboard will show the current value. If the setting displayed is acceptable, press the **MODE** switch to save it and advance to the next setup parameter. Otherwise, using the (+) switch to increase the value or the (-) switch to decrease the value, select the new setting and then press the **MODE** switch to save it and advance to the next setup parameter. Values from 0 to 9 and A may be selected.

0 = Disabled A = 10 Seconds

SETUP COMPLETED

The setup and configuration have been completed. The scoreboard will reset, display the software revision, pause, and then display the model number. Close and secure the front panel on the enclosure (install the four screws removed earlier) and proceed with normal operations.

OPTION CARD CONFIGURATION

This mode is automatic and is set to be in higher priority than serial communication. That means if the controller board has an option card attached, the controller board will display the *Option Card* message after the Rev version and SB250 welcome message for 2 seconds and then display weight. During this mode, the controller board will only look for data from the option card and will ignore serial data.

Currently, support option cards include:

- 2XX-RS232 – Serial Port card
- 2XX-SFP/2XX-SG – Serial Fiber Plastic or Serial Fiber Glass card
- 2XX-IP – Ethernet TCP/IP card
- 2XX-EIP – Industrial Ethernet/IP card
- 2XX-MODBUSTCP – ModbusTCP/IP card
- 2XX-DN – DeviceNet card.
- 2XX-SNAP – SnapStream card

PART IDENTIFICATION

ITEM #	QTY.	PART NUMBER	DESCRIPTION
1	1	3601-D462-0A	ENCLOSURE BACK WELDMENT
2	1	3601-D461-0A	FRONT PANEL ASSEMBLY
3	1	3601-B455-08	GASKET
4	1	3601-B457-0A	LANYARD CABLE ASSY
5	1	3601-B482-08	HINGE PIN
6	3	3601-B428-08	TRUSS HEAD CAPTIVE SCREW #10-32 X 1"
7	1	593GR986	SERIAL TAG
8	1	8200-B104-08	LABEL 2-5210 TERM BLOCK
9	1	8510-C346-01	LABEL HIGH VOLTAGE
10	1	3601-B414-0A	AC GROUND CABLE
11	1	3601-B415-0A	AC POWER CABLE
12	1	3601-B416-0A	DC POWER CABLE
13	1	3601-B417-0A	DAY/NIGHT SENSOR ASSEMBLY
14	1	3601-D431-0A	PCB, CONTROLLER, AUTO-LEARN, SB250/500
15	3	3601-D450-0A	PC BOARD ASSY
16	1	6550-0087	LABEL MADE IN THE USA
17	1	6800-1040	POWER SUPPLY 12V/5V UNIVERSAL INPUT
18	0.25	6610-5080	CONN BARRIER 24 GA TP 12 GA
19	2	6680-2105	SPACER #4-40 X 3/4"
20	4	6610-2248	CONN GLAND 0.187-0.312 GRIP 0.599 MTG BLK
21	1	6980-1030	POWER CORD 18/3 SVT CEE 6.3 FT
22	3	6680-0117	WASHER, FLAT #8 BLACK FIBER
23	5	6980-0014	WIRE TIE 4" BLACK
24	3	6610-5007	CABLE CLIP
25	1	6013-0315	NUT, HEX #6-32 SMALL PATTERN
26	26	6680-0040	WASHER, EXT TOOTH #6 Z/P
27	4	6680-0138	SPACER #6 X 0.187 NYLON
28	16	6021-2069	SCREW, TRUSS HEAD SHEET METAL #6-32 X 1/2"
30	2	6021-1551	SCREW, PAN HEAD SHEET METAL #6-32 X 1"
31	4	6021-0663	SCREW, PAN HEAD MACHINE #6-32 X 3/16"
32	3	6680-1083	FASTENER, RIVNUT #10-32 X 0.781 CLOSED END
33	0.1	6560-0103	SEALANT CLEAR SILICON RUBBER
34	1	3601-C480-08	BRACKET PC BD.
35	1	3601-B485-08	SPACER
36	1	3601-C486-08	COVER, POWER SUPPLY
37	3	6680-0217	SPACER #6-32 X 1.5 NYLON
38	1	6540-1104	HOLE PLUG SMALL GLAND

PART IDENTIFICATION, CONT.

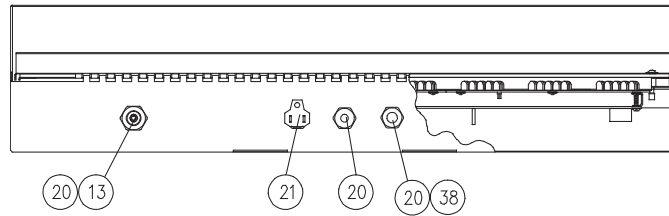
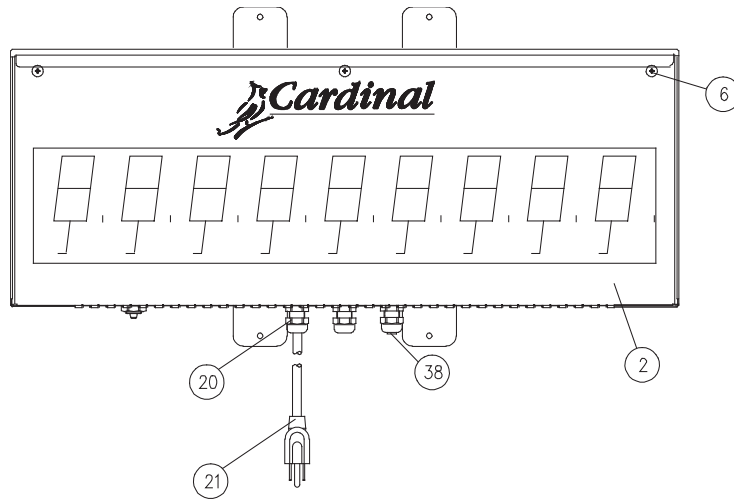

PART IDENTIFICATION, CONT.

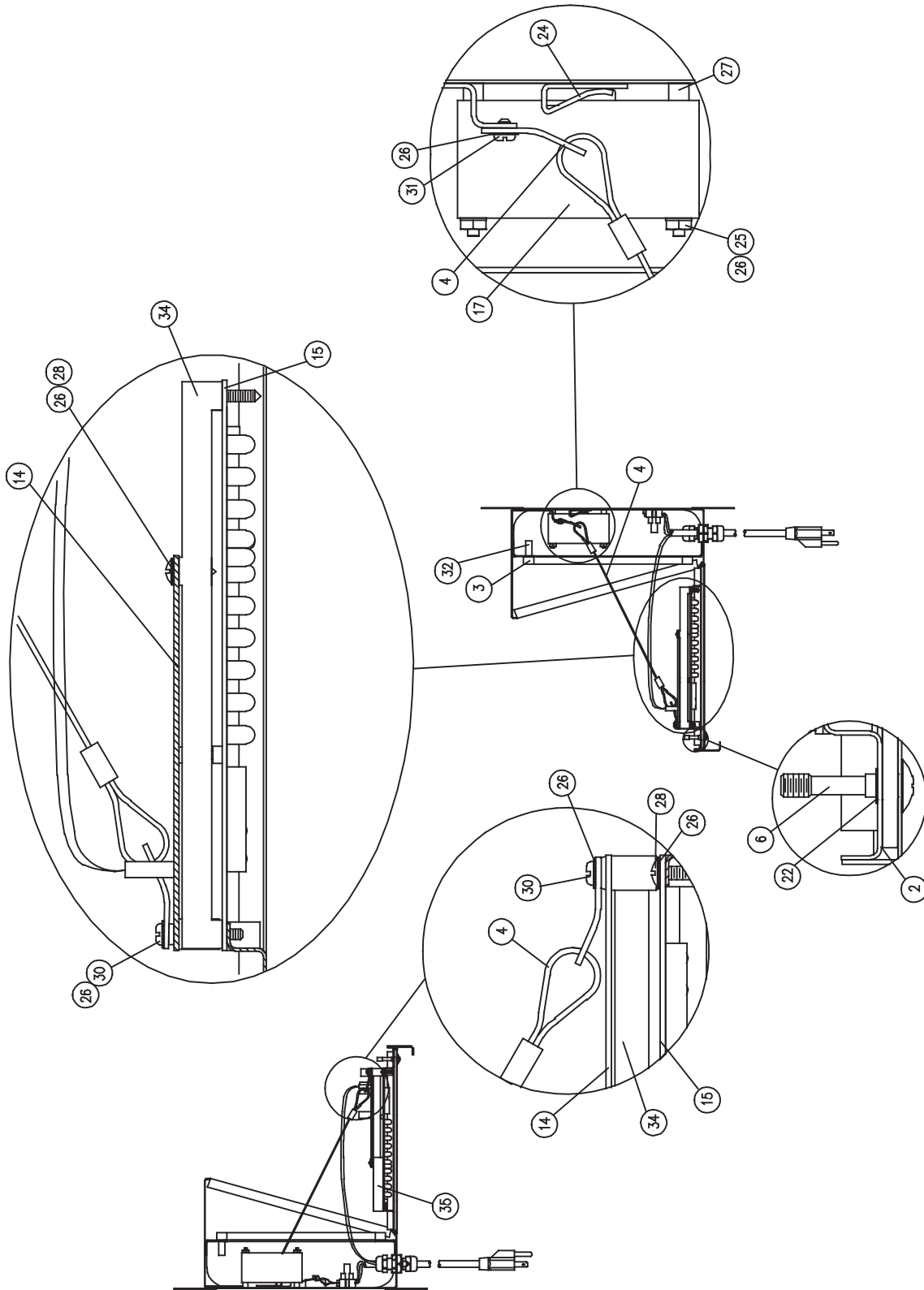

PART IDENTIFICATION, CONT.

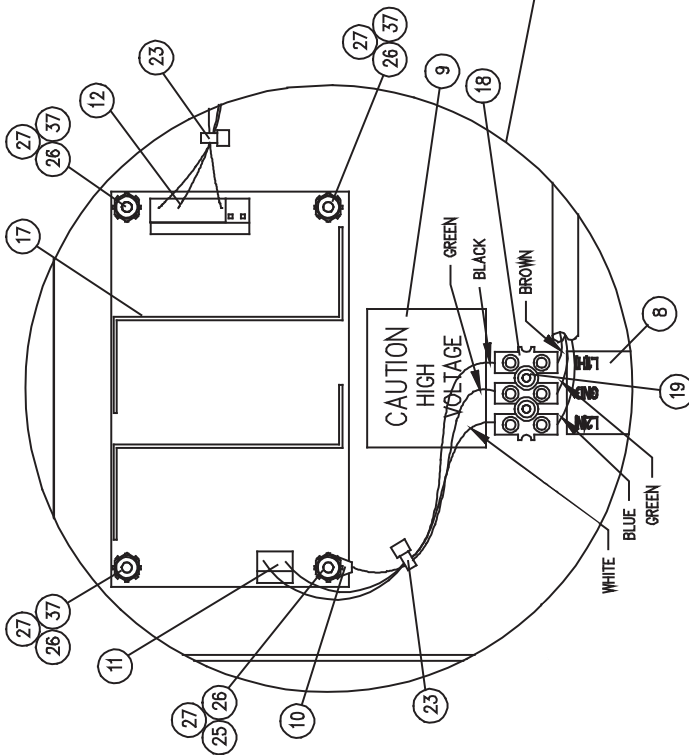
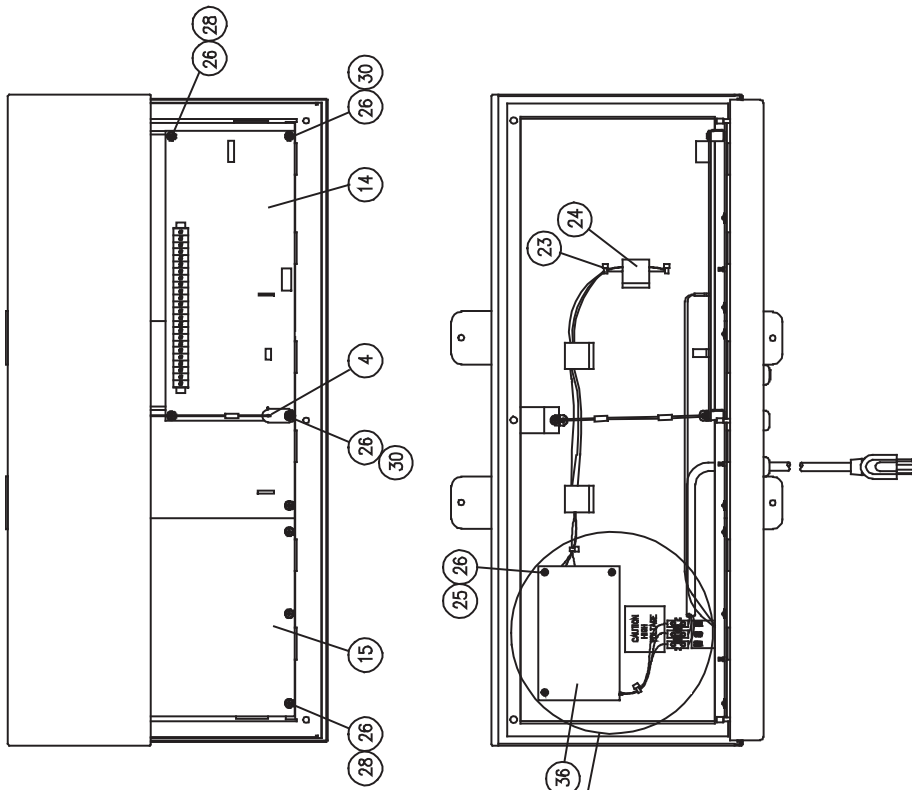

STATEMENT OF LIMITED WARRANTY

WARRANTY TERMS

Cardinal Scale Manufacturing Company warrants the equipment we manufacture against defects in material and workmanship. The length and terms and conditions of these warranties vary with the type of product and are summarized below:

PRODUCT TYPE	TERM	MATERIAL AND WORKMANSHIP	LIGHTNING DAMAGE See note 9	WATER DAMAGE See note 7	CORROSION See note 4	ON-SITE LABOR	LIMITATIONS AND REQUIREMENTS
WEIGHT INDICATORS	90 DAY REPLACEMENT ----- 1 YEAR PARTS	YES	YES	YES	YES	NO	1, 2, 3, 5, 6 A, B, C, D
LOAD CELLS (Excluding Hydraulic)	1 YEAR	YES	YES	YES	YES	NO	1, 2, 3, 5, 6 A, B, C, D
HYDRAULIC LOAD CELLS (When purchased with Guardian Vehicle Scale)	LIFETIME	YES	YES	YES	YES	90 DAYS	1, 5, 6, 8 A, B, C, D
HYDRAULIC LOAD CELLS (When purchased separately)	10 YEARS	YES	YES	YES	YES	NO	1, 5, 6, 8, 9 A, B, C, D
VEHICLE SCALE (Deck and Below Excl. PSC Series)	5 YEARS	YES	YES	YES	YES	90 DAYS	1, 2, 3, 5, 6 A, B, C, D, E
LSC SCALE (Deck and Below)	3 YEARS	YES	YES	YES	YES	90 DAYS	1, 2, 3, 5, 6, 11 A, B, C, D
GUARDIAN FLOOR SCALES	10 YEARS	YES	YES	YES	YES	NO	1, 2, 3, 5, 6, 9, 10 A, B, C, D
ALL OTHER CARDINAL PRODUCTS	1 YEAR	YES	YES	YES	YES	NO	1, 2, 5, 6 A, B, C, D, E
REPLACEMENT PARTS	90 DAYS	YES	YES	YES	YES	NO	1, 2, 4, 5, 6 A, B, C, D
SWIM AND 760 SERIES VEHICLE SCALES	1 YEAR	YES	YES	YES	YES	90 DAYS	1, 2, 5, 6 A, B, C, D
SOFTWARE	90 DAYS	YES	N/A	N/A	N/A	NO	1, 6 B, C, D
CONVEYOR BELT SCALES (including Belt-Way)	1 YEAR	YES	YES	YES	YES	NO	1, 2, 3, 5, 6 A, B, C, D, E, F



CARDINAL

Ph. (800) 441-4237
E-mail: cardinal@cardet.com
102 E. Daugherty
Webb City, MO 64870

04/24
Printed in USA
315-WARRANTY-CAR-M

APPLICABLE LIMITATIONS AND REQUIREMENTS

1. This warranty applies only to the original purchaser. The warranty does not apply to equipment that has been tampered with, defaced, damaged, or had repairs or modifications not authorized by Cardinal or has had the serial number altered, defaced or removed.
2. This warranty is not applicable to equipment that has not been grounded in accordance with Cardinal's recommendations.
3. This equipment must be installed and continuously maintained by an authorized Cardinal / Belt-Way dealer.
4. Applies only to components constructed from stainless steel.
5. This warranty does not apply to equipment damaged in transit. Claims for such damage must be made with the responsible freight carrier in accordance with freight carrier regulations.
6. Warranty term begins with date of shipment from Cardinal.
7. Only if device is rated NEMA 4 or better or IP equivalent.
8. Lifetime warranty applies to damages resulting from water, lightning, and voltage transients and applies only to the hydraulic load cell structure itself (does not include pressure transducers, rubber seals, o-rings, and associated wiring).
9. 10-Year prorated warranty on hydraulic load cells.
10. 1-Year warranty for scale structure.
11. PSC models' warranty coverage applies only to agricultural installations on farms up to 3,000 acres (LSC models not limited in this manner).
12. Load cell kits MUST be installed in accordance with Cardinal Scale instructions. Failure to follow these instructions will void the warranty.

EXCLUSIONS

- A.) This warranty does not include replacement of consumable or expendable parts. The warranty does not apply to any item that has been damaged due to unusual wear, abuse, improper line voltage, overloading, theft, fire, water, prolonged storage or exposure while in purchaser's possession or acts of God unless otherwise stated herein.
- B.) This warranty does not apply to peripheral equipment not manufactured by Cardinal. This equipment will normally be covered by the equipment manufacturer's warranty.
- C.) This warranty sets forth the extent of our liability for breach of any warranty or deficiency in connection with the sale or use of our product. Cardinal will not be liable for consequential damages of any nature, including but not limited to loss of profit, delays or expenses, whether based on tort or contract. Cardinal reserves the right to incorporate improvements in material and design without notice and is not obligated to incorporate said improvements in equipment previously manufactured.
- D.) This warranty is in lieu of all other warranties expressed or implied including any warranty that extends beyond the description of the product including any warranty of merchantability or fitness for a particular purpose. This warranty covers only those Cardinal products installed in the forty-eight contiguous United States and Canada.
- E.) This warranty does not cover paint coatings due to the variety of environmental conditions.
- F.) Do not cut load cell cables on load cells returned for credit or warranty replacement. Cutting the cable will void the warranty.
- G.) Software is warranted only for performance of the functions listed in the software manual and/or the Cardinal proposal.
- H.) The software warranty does not cover hardware. Warranties on hardware are provided from the hardware vendor only.
- I.) The software warranty does not cover interfacing issues to non-Cardinal supplied hardware.
- J.) The software warranty does not include automatic software upgrades unless purchased separately.



Ph. (800) 441-4237
E-mail: cardinal@cardet.com
102 E. Daugherty
Webb City, MO 64870

04/24
Printed in USA
315-WARRANTY-CAR-M

Cardinal Scale Mfg. Co.

102 E. Daugherty, Webb City, MO 64870 USA

Ph: 417-673-4631 or 1-800-641-2008

Fax: 417-673-2153

www.cardinalscale.com

Technical Support: 1-866-254-8261

E-mail: tech@cardet.com

Printed in USA

3601-M481-O1 Rev D 08/24