



CARDINAL®



SMARTCELL®
DIGITAL LOAD CELLS

Model 225D

**Weight Indicator for Digital Scales
Installation and Technical Manual**

INTRODUCTION

The Cardinal Model 225D Weight Indicator for Digital Scales (225D-D Desktop and 225D-S Stainless Steel) has been designed specifically for use with Cardinal digital scales and digital conversion systems. The software in the 225D provides in-depth diagnostics, simplified calibration, and easy maintenance. The system is comprised of two components: a 225 Desktop (or 225 Stainless Steel) Weight Indicator with digital scale software, and a 195/225 DLC (Digital Load Cell) interface card installed in the SCALE/DLC card slot.

To communicate with the 225D Weight Indicator for Digital Scales, the scale must be equipped with Cardinal Scale's SCBD SmartCells, DC Digital Load Cells, or a SMARTCAN Digital Conversion System.

This manual provides instructions for the setup, configuration, and diagnostics of the Model 225D Weight Indicator for Digital Scales. It is supplied as a supplement to the Model 225 Desktop Weight Indicator Installation and Technical Manual (8200-0870-0M) and the Model 225 Stainless Steel Weight Indicator Installation and Technical Manual (8200-0873-0M). The standard indicator manual should be consulted for information concerning the installation and functions of the indicator. Please read both manuals carefully before installing your indicator and keep them available for future reference.

This manual applies to the Model 225D-D and 225D-S Weight Indicators for Digital Scales.

COPYRIGHT

All rights reserved. Reproduction or use, without expressed written permission, of editorial or pictorial content, in any manner, is prohibited. No patent liability is assumed with respect to the use of the information contained herein.

DISCLAIMER

While every precaution has been taken in the preparation of this manual, the Seller assumes no responsibility for errors or omissions. Neither is any liability assumed for damages resulting from the use of the information contained herein. All instructions and diagrams have been checked for accuracy and ease of application; however, success and safety in working with tools depend largely upon the individual's accuracy, skill, and caution. For this reason, the Seller is not able to guarantee the result of any procedure contained herein. Nor can they assume responsibility for any damage to property or injury to persons occasioned from the procedures. Persons engaging in the procedures do so entirely at their own risk.

SERIAL NUMBER _____
DATE OF PURCHASE _____
PURCHASED FROM _____

RETAIN THIS INFORMATION FOR FUTURE USE

SAFETY AND WARNINGS

Before using this indicator, read this manual and pay special attention to all "NOTIFICATION" symbols.

Avant d'utiliser cet indicateur, lisez ce manuel et portez une attention particulière à tous les symboles "NOTIFICATION".

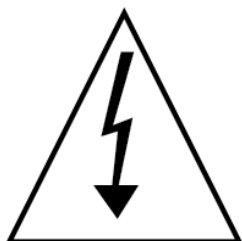

ELECTRICAL WARNING

AVERTISSEMENT
ÉLECTRIQUE



IMPORTANT

IMPORTANT



STATIC SENSITIVE

SENSIBLE À
L'ÉLECTRICITÉ STATIQUE



The protective conductor terminal (Earth Ground) is signified by this symbol. It must be properly connected to earth ground per local electrical codes.

La borne du conducteur de protection (mise à la terre) est représentée par ce symbole. Elle doit être correctement connectée à la terre conformément aux codes électriques locaux.

WARNING



WARNING: RISK OF ELECTRICAL SHOCK. DO NOT REMOVE COVER, NO USER-SERVICEABLE PARTS INSIDE. DEVICE IS ONLY TO BE SERVICED BY TRAINED SERVICE PERSONNEL OR AUTHORIZED CARDINAL SCALE SERVICE PERSONNEL.

AVERTISSEMENT: RISQUE DE CHOC ÉLECTRIQUE. NE PAS RETIRER LE COUVERCLE, AUCUNE PIÈCE RÉPARABLE PAR L'UTILISATEUR À L'INTÉRIEUR. L'APPAREIL NE DOIT ÊTRE ENTRETENU QUE PAR UN PERSONNEL DE SERVICE QUALIFIÉ OU PAR LE PERSONNEL AGRÉÉ DE CARDINAL SCALE.

WARNING



If the equipment is used in a manner not specified by the manufacturer, the protection provided by the equipment may be impaired.

Si l'équipement est utilisé d'une manière non spécifiée par le fabricant, la protection fournie par l'équipement peut être compromise.

PROPER DISPOSAL

When this device reaches the end of its useful life, it must be properly disposed of. It must not be disposed of as unsorted municipal waste. Within the European Union, this device should be returned to the distributor from where it was purchased for proper disposal. This is in accordance with EU Directive 2002/96/EC. Within North America, the device should be disposed of in accordance with the local laws regarding the disposal of waste electrical and electronic equipment.

It is everyone's responsibility to help maintain the environment and to reduce the effects of hazardous substances contained in electrical and electronic equipment on human health. Please do your part by making certain that this device is properly disposed of. The symbol shown to the right indicates that this device must not be disposed of in unsorted municipal waste programs.



CAUTION



CAUTION: RISK OF EXPLOSION IF BATTERY IS REPLACED BY AN INCORRECT TYPE. DISPOSE OF USED BATTERIES ACCORDING TO THE INSTRUCTIONS.

ATTENTION: RISQUE D'EXPLOSION SI LA BATTERIES EST REMPLAC'E PAR UN TYPE INCORRECT. REJETEZ LES BATTERIES UTILISE'ES SELON LES INSTRUCTIONS.

Contains FCC ID: 2AC7Z-ESP32WROVERE

1. This device complies with Part 15 of the FCC rules. Operation is subject to the following two conditions:
 - (1) This device may not cause harmful interference.
 - (2) This device must accept any interference received, including interference that may cause undesired operation.
2. Changes or modifications not expressly approved by the party responsible for compliance could void the user's authority to operate the equipment.

FCC RADIATION EXPOSURE STATEMENT

This equipment complies with FCC RF radiation exposure limits set forth for an uncontrolled environment. This transmitter must not be co-located or operated in conjunction with any other antenna or transmitter.

TABLE OF CONTENTS

INTRODUCTION	Page I
SAFETY AND WARNINGS	Page II
PROPER DISPOSAL, CAUTION, and FCC RADIATION EXPOSURE	Page III
SPECIFICATIONS	Page 1
195/225-DLC CONTROLLER CARD	Page 3
HOMERUN CABLE INSTALLATION	Page 5
POWER-DLC Internal Connections	Page 6
POWER-DLC to Scale Connection	Page 7
POWER-DLC to 195/225-DLC Controller Card Connection	Page 8
Re-Installing the POWER-DLC Cover	Page 8
POWER-DLC to 225D Indicator Connection	Page 9
225D-D Desktop Indicator	Page 9
225D-S Stainless Steel Indicator	Page 10
POWER-DLC to Load Cell Connection	Page 13
SETUP AND CONFIGURATION	Page 16
To Begin Setup and Configuration	Page 18
LOAD CELL ASG (Load Cell Assignments)	Page 19
END NODES	Page 21
Calibration	Page 22
Smart Calibration	Page 23
Zero Calibration	Page 27
Trim Cells	Page 27
Span Adjust (Adjust Scale Span)	Page 30
DIGITAL SCALE DIAGNOSTICS	Page 31
On-Screen Diagnostics	Page 31
Cell Diagnostics	Page 37
Hardware Diagnostics	Page 44
DLC CONTROLLER CARD REPLACEMENT	Page 45
DETECTING BOARD REPLACEMENTS	Page 47
Detecting Mainboard or DLC Controller Card Replacement	Page 47
Mainboard Replaced	Page 47
Mainboard NOT Replaced	Page 47
DLC Controller Card Replaced	Page 48
DLC Controller Card NOT Replaced	Page 48
ISITE CONFIGURATION	Page 49
ISITE IP CONFIG Menu	Page 49
ISITE ADVANCED CONFIG Menu	Page 52

SPECIFICATIONS

Enclosure Type:	
225D-D	Painted Mild Steel Desktop Mount
225D-S	Stainless Steel, Indoor or Outdoor Use, Wall, or Desk Mount
Enclosure Rating:	NEMA 4X/IP66
Enclosure Size:	
225D-D	12" W x 9.875" H x 7.625" D (305mm W x 251mm H x 194mm D)
225D-S	12" W x 10 1/2" H x 3 1/8" D (304mm W x 267mm H x 79mm D)
Weight:	
225D-D	8.7 lb (3.95 kg)
225D-S	9 lb (4.1 kg) – <i>Size and Weight DOES NOT include Gimbal</i>
Power Requirements:	100-240 VAC +/- 10%, 50/60 Hz, 1.0 A
Operating Environment:	Temperature: 14 to 104 °F (-10 to +40 °C) Humidity: 90% non-condensing (maximum)
Operating Altitude:	10,000 ft (approx. 3,000 m)
Division Value:	Commercial: 1, 2, or 5 x 10, 1, 0.1, 0.01, 0.001, and 0.0001 Non-commercial: 0 to 99
Sensitivity:	
NON-COMMERCIAL	0.15 uV/e
NTEP	0.3uV/e (Class III/IIIL)
CANADA	0.3uV/e (Class III/IIHHD)
OIML	0.7 uV/e (Class III)
Scale Divisions:	
NON-COMMERCIAL	100 to 240,000
NTEP	100 to 10,000 (Class III/IIIL)
CANADA	100 to 10,000 (Class III/IIHHD)
OIML	100 to 10,000 (Class III)
Internal Resolution:	1 part in 16,777,216
Tare Capacity:	Six Digits (999,999)
Sample Rate:	1 to 100 samples per second, selectable
Auto Zero Range:	0.5 or 1 to 9 divisions
Weighing Units:	Tons, Pounds, Ounces, Tonnes "Metric Tons", Kilograms, Grams,

SPECIFICATIONS, CONT.

Display:	640 x 320 (5.5" x 2.75") Graphics TFT LCD w/ LED Backlight
Keypad:	Membrane type with 60 color-coded keys
Standard I/O:	1 ea. Bi-directional RS-232 or bidirectional RS485 1 ea. Bi-directional RS-232 or bidirectional 20mA port 1 ea. 10/100 Base-T Ethernet 1 ea. USB A Host Port 1 ea. USB B Micro Device Port 8 ea. Remote Isolated Inputs 8 ea. Remote Isolated Outputs 4 ea. Color Bar Ports 802.11b/g/n Wi-Fi Bluetooth v4.2 BR/EDR/BLE
195/225-DLC Connections:	Homerun Cable – 5-position spring cage clamp (24 to 16 Ga wire) Ethernet Port for iSite – (1) RJ-45 Micro USB port – Used for firmware updates to 195/225-DLC Controller card
Homerun Cable Length:	Consult the factory for other requirements.
Number of Load Cells:	Up to 20 Cardinal Digital Load Cells with POWER-DLC

195/225-DLC CONTROLLER CARD

Jumpers, Connectors, and LEDs

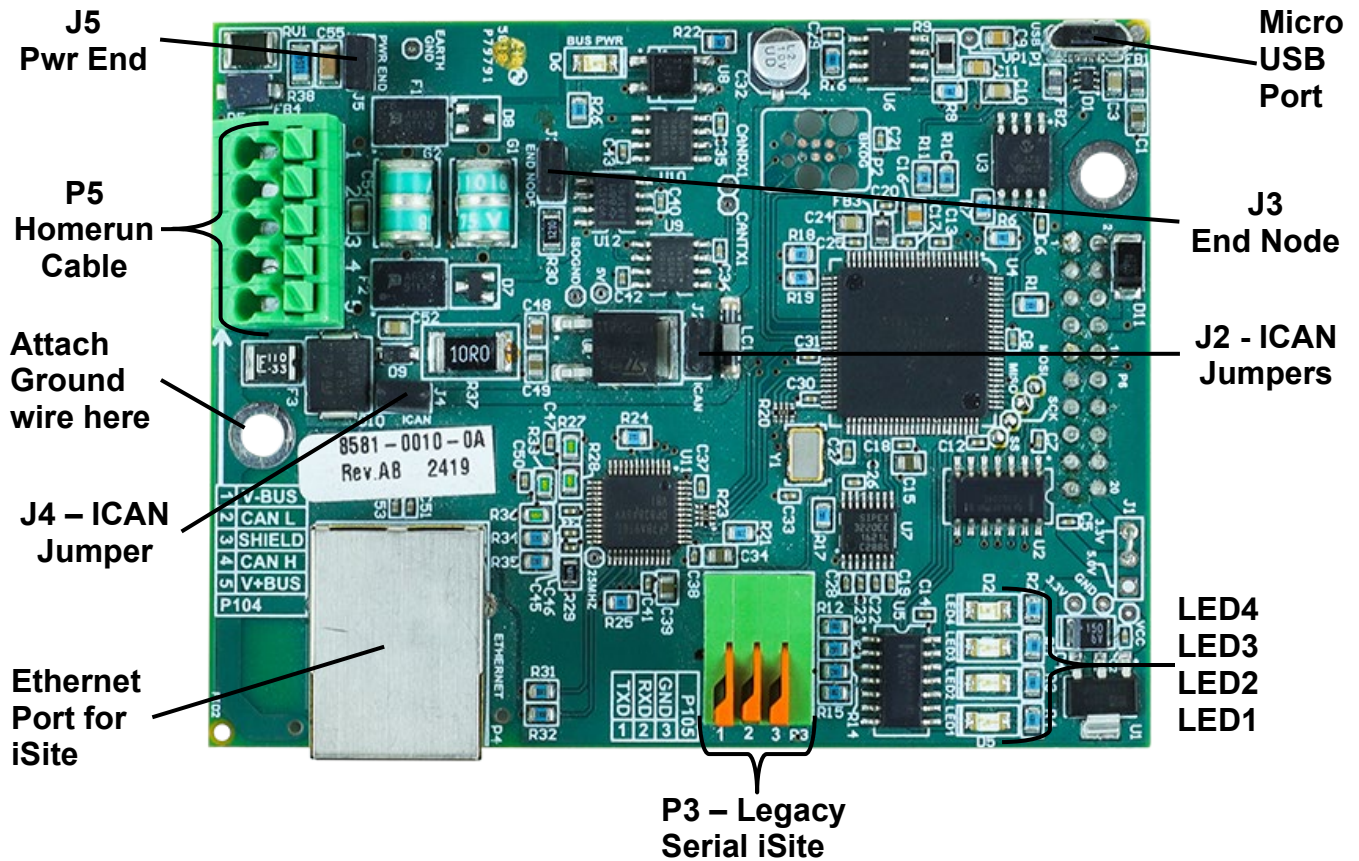

Figure No. 1

Ethernet Port

The Ethernet port is used to connect the 225D to your network to send information to the cloud for iSite.

LED 1-4

The LEDs are used for diagnostic purposes. For a complete explanation of their function, refer to the DIGITAL SCALE DIAGNOSTICS, Hardware Diagnostics section of this manual.

Micro USB Port

This port is used to perform firmware updates to the 195/225-DLC controller card.

J1, 3.3V / 5.0V Jumper

Jumper J1 **must** be installed in the 3.3V position to be able to communicate with the 225D Mainboard.

J3, End Node Jumper

Jumper J3 is the CAN bus END NODE jumper and **must** be installed for the 225D communications to the scale to operate.

195/225-DLC CONTROLLER CARD, CONT.

Jumpers, Connectors, and LEDs Cont.

J2, J4 ICAN Jumpers

When ON (installed), the J2, J4 ICAN jumpers enable the 225D indicator to supply 15 VDC power to the digital load cells. For operation using an external power source, such as the POWER-DLC 24 VDC power supply/noise filter for digital load cell systems or a customer-supplied 12–24 VDC power supply, the J2, J4 ICAN jumpers must be set to OFF (placed on a single pin or removed).



IMPORTANT! When using an external power source, the J2, J4 ICAN jumpers must be OFF (on one pin only or removed). A 12 to 24 VDC supply must then be connected to the **V+BUS** terminal, with the ground return connected to the **V-BUS** terminal of the P5 terminal block.

J5, Pwr End Jumper

Jumper J5 should be installed if the power to the digital load cells or a SMARTCAN System junction box is provided by the 225D power supply and not an external power source.

P3, Legacy Serial iSite

This portion of the P4 terminal block is used to connect to Legacy Serial iSite wiring when replacing or updating the indicator in an older system with a 225D.

P5, Homerun Cable

The P5 terminal block is used to connect the homerun cable between the 225D indicator and the first load cell in the loop (Start Node in the scale). Refer to the table below for terminal connections.

Homerun Cable Connection to P5 Terminal Block

Board Label	Homerun Cable Wire Color	Wire Color if using a Load Cell Cable
V-BUS	BLACK	BLUE
CAN L	BLUE or LIGHT BLUE	GRAY
SHIELD	GRAY	BROWN
CAN H	WHITE	BLACK
V+BUS	RED	WHITE

HOMERUN CABLE INSTALLATION

Homerun Cable Installation

The Homerun Cable is a five-conductor, shielded PVC cable. On the indicator side, a short section connects to the INDICATOR terminal block in the POWER-DLC and terminates at the P5 terminal block on the 195/225-DLC controller Card. On the load cell side, the main cable section connects to the SCALE terminal block in the POWER-DLC, with the load cell end terminated using a 5-pin actuation lever-type connector from the Home Run Cable Connector Pack. For more information, see the Load Cell Connection section of this manual and refer to the table below for cable and connector specifications.

Cable and Connector Information Table

ITEM and DESCRIPTION	CARDINAL PART NO.
HOMERUN CABLE, 5 CONDUCTORS, SHIELDED PVC (CONTAINS 2 x 18AWG, 2 x 22AWG, AND 1 x 22AWG)	6980-1092
CONNECTOR PACK, HOME RUN CABLE (INCLUDES 5-PIN SPRING CAGE CONNECTOR, 6610-1258)	3502-0681-0A
RECOMMENDED HOMERUN CABLE BELDEN 5303FE, 18 AWG, 5 CONDUCTORS	SUPPLIED BY DEALER

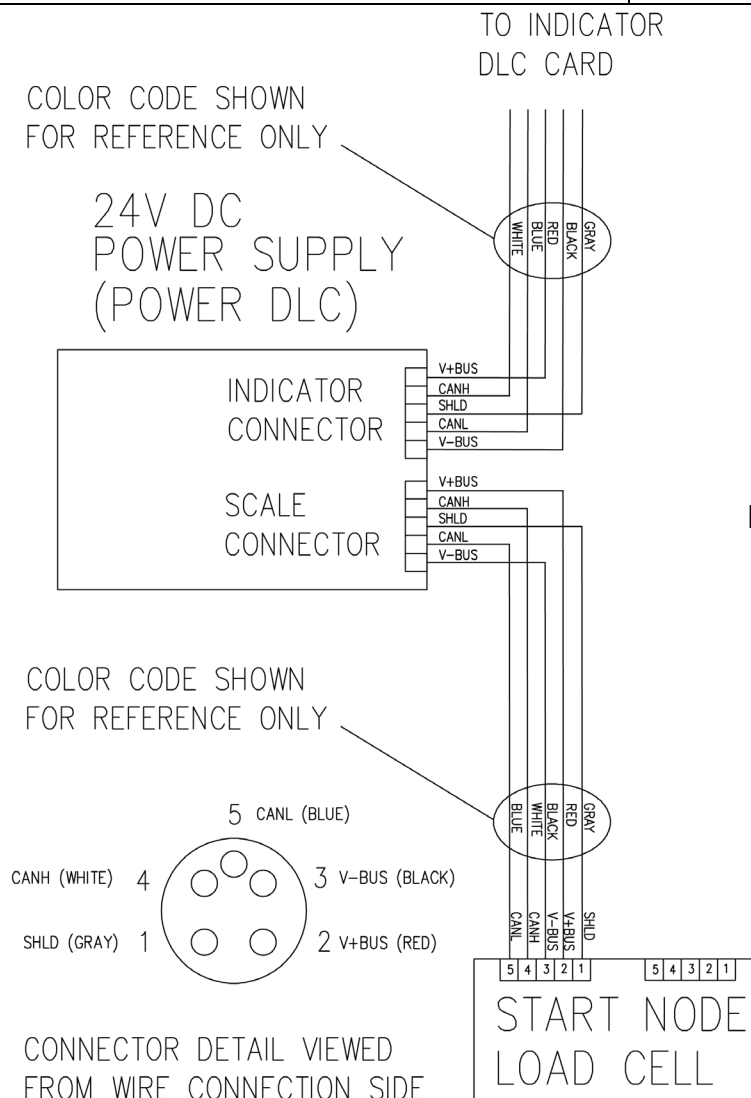

Figure No. 2

HOMERUN CABLE INSTALLATION, CONT.

POWER-DLC Internal Connections

The main (longer) section of the Homerun Cable is connected to the first load cell in the loop (the Start Node) and the SCALE terminal block in POWER-DLC. A (shorter) section of Homerun Cable is connected to the INDICATOR terminal block in the POWER-DLC and the P5 terminal block on the 195/225-DLC controller Card.



IMPORTANT! MAKE SURE THE ICAN JUMPERS (J2 AND J3 ON THE 195/225-DLC CARD) ARE REMOVED BEFORE APPLYING POWER!

Homerun Cable to Scale

Homerun Cable from Indicator 195/225-DLC Card

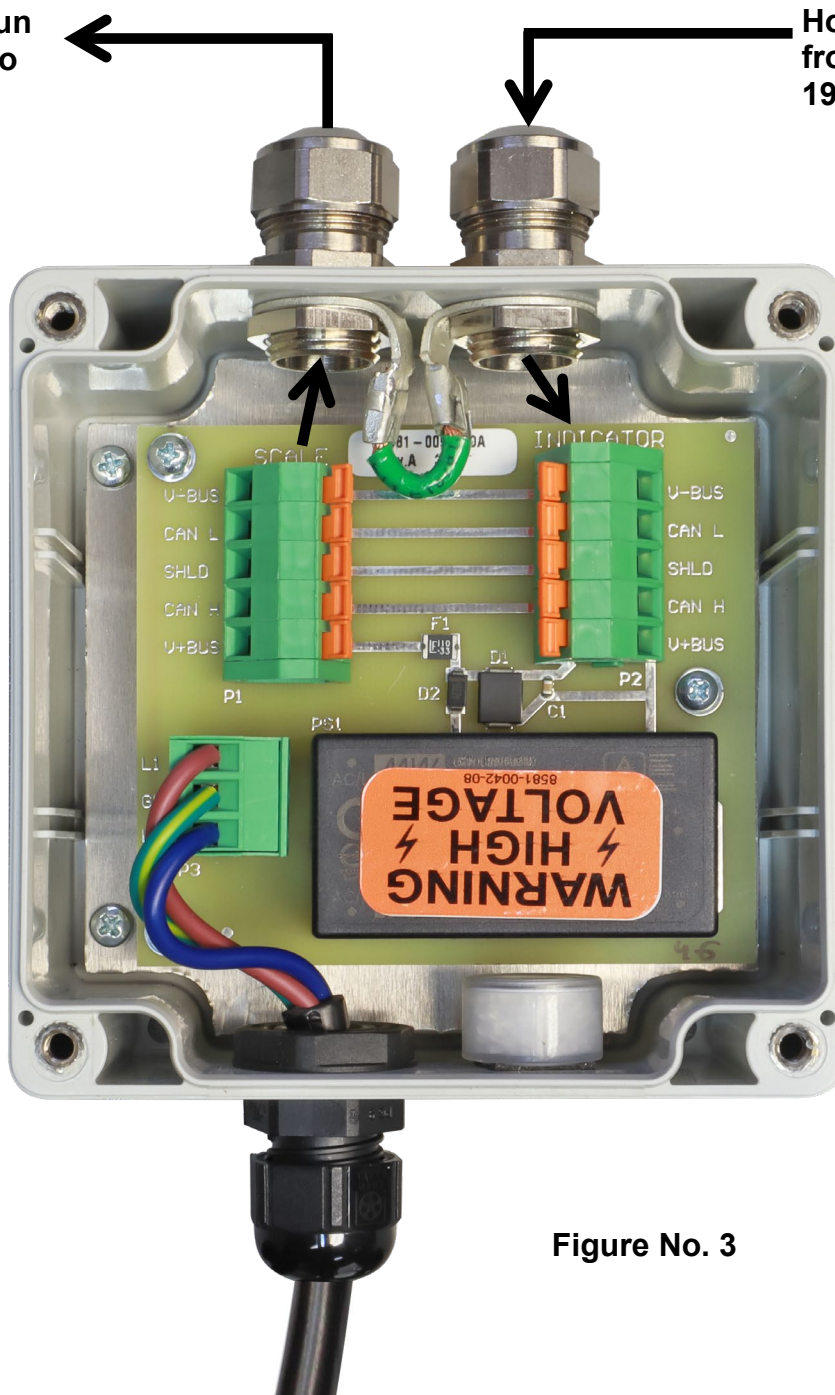

Figure No. 3

HOMERUN CABLE INSTALLATION, CONT.

POWER-DLC to Scale Connection

The homerun cable to the scale should be routed through the special metallic gland connector in the POWER-DLC, and the homerun cable shield connected to the metal gland connector for grounding. Refer to Figure No. 3 for the POWER-DLC gland connector layout.

1. Remove the four screws securing the cover of the POWER-DLC.

2. Loosen and remove the metal gland connector nut, then remove the plastic insert.

3. Slip the homerun cable to the scale through the nut and plastic insert.

4. Remove approximately 3.0 inches (76 mm) of the homerun cable outer jacket, exposing the cable shield and internal wires.

5. Cut the cable shield so it extends past the outer jacket approximately 3/4 inches (19 mm).

6. Next, remove approximately 1/4 inch (6 mm) of the insulation from each of the five wires.

7. Slide the plastic insert up the cable and fold the cable shield back over the plastic insert.

8. Insert the plastic insert (with the cable shield) into the metal gland connector for the scale. The cable shield will be secured when tightening the gland connector nut.

9. Make sure the gland connector nut is tight, but do not over-tighten it.

10. With the homerun cable to the scale routed into the POWER-DLC, refer to the table below (or the circuit board) for terminal connections, and connect each wire to the SCALE terminal block on the POWER-DLC board.

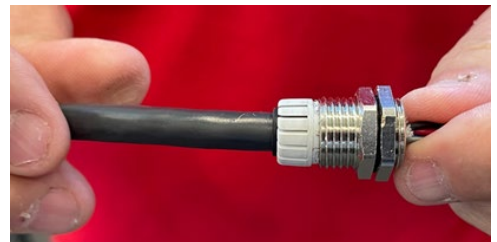

POWER-DLC SCALE Connector Terminal Connections

Board Label	Homerun Cable Wire Color	Wire Color if using a Load Cell Cable
V-BUS	BLACK	BLUE
CAN L	BLUE or LIGHT BLUE	GRAY
SHIELD	GRAY	BROWN
CAN H	WHITE	BLACK
V+BUS	RED	WHITE

11. Using a small flat-blade screwdriver, press down on the release bar for the terminal, insert the wire into the opening, and then remove the screwdriver. The release bar will return to its original position, locking the wire in place.

12. Repeat steps 10 and 11 until all five wires of the homerun cable to the scale are installed in the SCALE terminal block on the POWER-DLC board.

HOMERUN CABLE INSTALLATION, CONT.

POWER-DLC to 195/225-DLC Controller Card Connection

The homerun cable from the 195/225-DLC controller card should be routed through the special metallic gland connectors in the POWER-DLC, and the cable shield from the cable connected to the metal gland connector for grounding. Refer to Figure No. 3 for the POWER-DLC gland connector layout and the images on the previous page for installing the homerun cable shield in the gland connector.

1. With the cover off from the previous operation, loosen and remove the metal gland connector nut, then remove the plastic insert.
2. Slip the homerun cable from the 195/225-DLC controller card through the nut and plastic insert.
3. Remove approximately 3.0 inches (76 mm) of the homerun cable outer jacket, exposing the cable shield and internal wires.
4. Cut the cable shield so it extends past the outer jacket approximately 3/4 inches (19 mm).
5. Next, remove approximately 1/4 inch (6 mm) of the insulation from each of the five wires.
6. Slide the plastic insert up the cable and fold the cable shield back over the plastic insert.
7. Insert the plastic insert (with the cable shield) into the metal gland connector for the indicator. The cable shield will be secured when tightening the gland connector nut.
8. Make sure the gland connector nut is tight, but do not over-tighten it.
9. With the homerun cable from the 195/225-DLC controller card routed into the POWER-DLC, refer to the table below (or the circuit board) for terminal connections, and connect each wire to the INDICATOR terminal block on the POWER-DLC board.

POWER-DLC TERMINAL Connector Terminal Connections

Board Label	Homerun Cable Wire Color	Wire Color if using a Load Cell Cable
V-BUS	BLACK	BLUE
CAN L	BLUE or LIGHT BLUE	GRAY
SHIELD	GRAY	BROWN
CAN H	WHITE	BLACK
V+BUS	RED	WHITE

10. Using a small flat-blade screwdriver, press down on the release bar for the terminal, insert the wire into the opening, and then remove the screwdriver. The release bar will return to its original position, locking the wire in place.
11. Repeat steps 9 and 10 until all five wires of the homerun cable to the scale are installed in the SCALE terminal block on the POWER-DLC board.

Re-Installing the POWER-DLC Cover

1. After all connections to the SCALE and INDICATOR terminal blocks have been made, secure the POWER-DLC cover with the four screws removed earlier, following a diagonal pattern when tightening the screws.
2. Using a torque wrench, tighten the metal gland connectors to 33 in-lb (3.7 Nm).

HOMERUN CABLE INSTALLATION, CONT.

POWER-DLC to 225D Indicator Connection

225D-D Desktop Indicator

The short section of Homerun Cable from the INDICATOR terminal block in the POWER-DLC should be routed through the metallic gland connector, identified as **Digital Scale**, in Figure No. 4 (225D-D Gland Connector Layout).

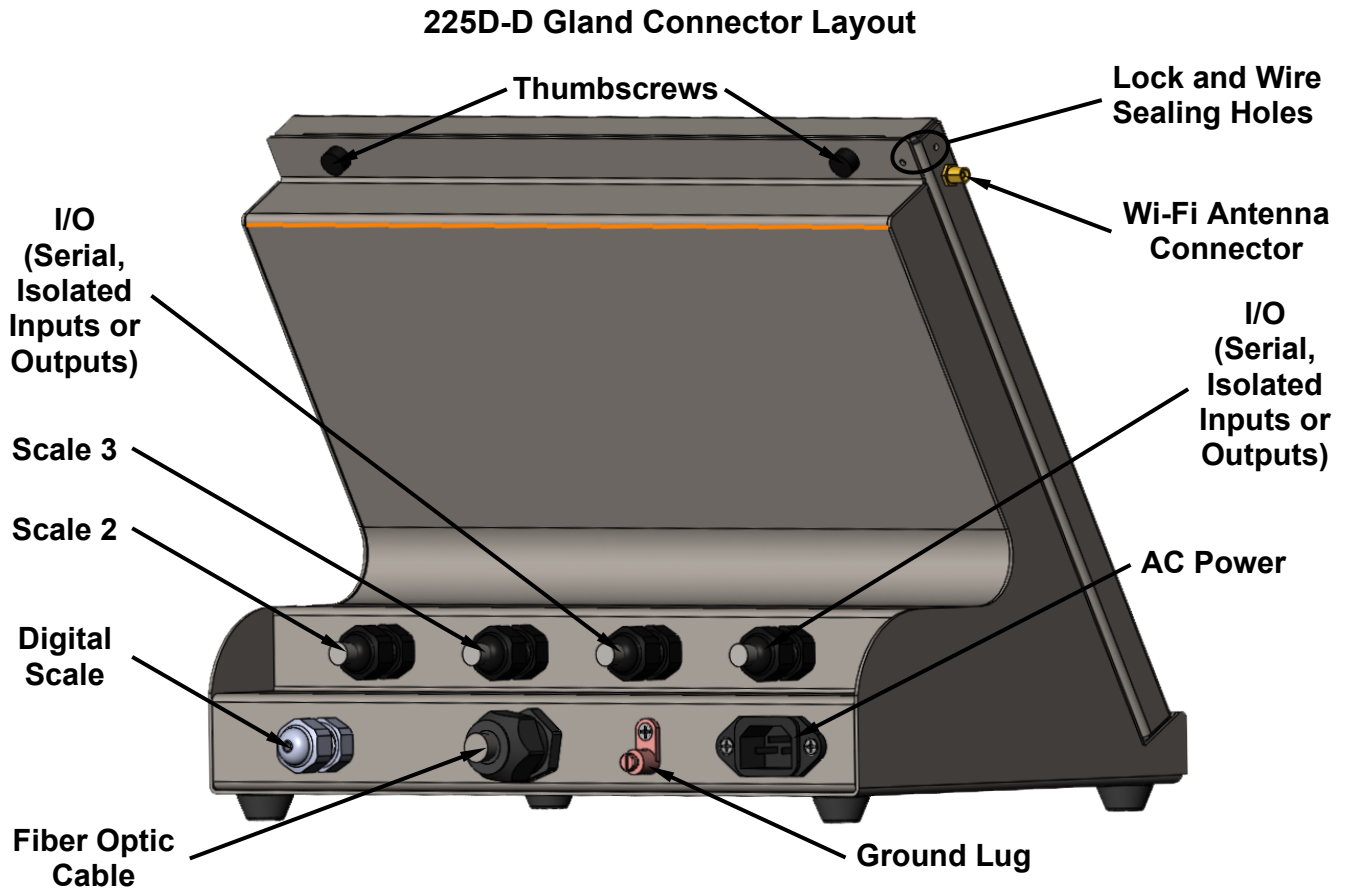

Figure No. 4



ATTENTION! OBSERVE PRECAUTIONS FOR HANDLING ELECTROSTATIC SENSITIVE DEVICES!

1. Referring to Figure No. 4, remove the 2 thumbscrews securing the front panel to the rear enclosure, and then lower the front panel.
2. Loosen and remove the metal gland connector nut, then take out the plastic insert.
3. Route the homerun cable through the nut and plastic insert and into the enclosure.
4. Proceed to Step 5 on Page 11 to complete installing the homerun cable.

HOMERUN CABLE INSTALLATION, CONT.

POWER-DLC to 225D Indicator Connection, Cont.

225D-S Stainless Steel Indicator

The short section of Homerun Cable from the INDICATOR terminal block in the POWER-DLC should be routed through the metallic gland connector, identified as **Digital Scale**, in Figure No. 5 (225D-S Gland Connector Layout).

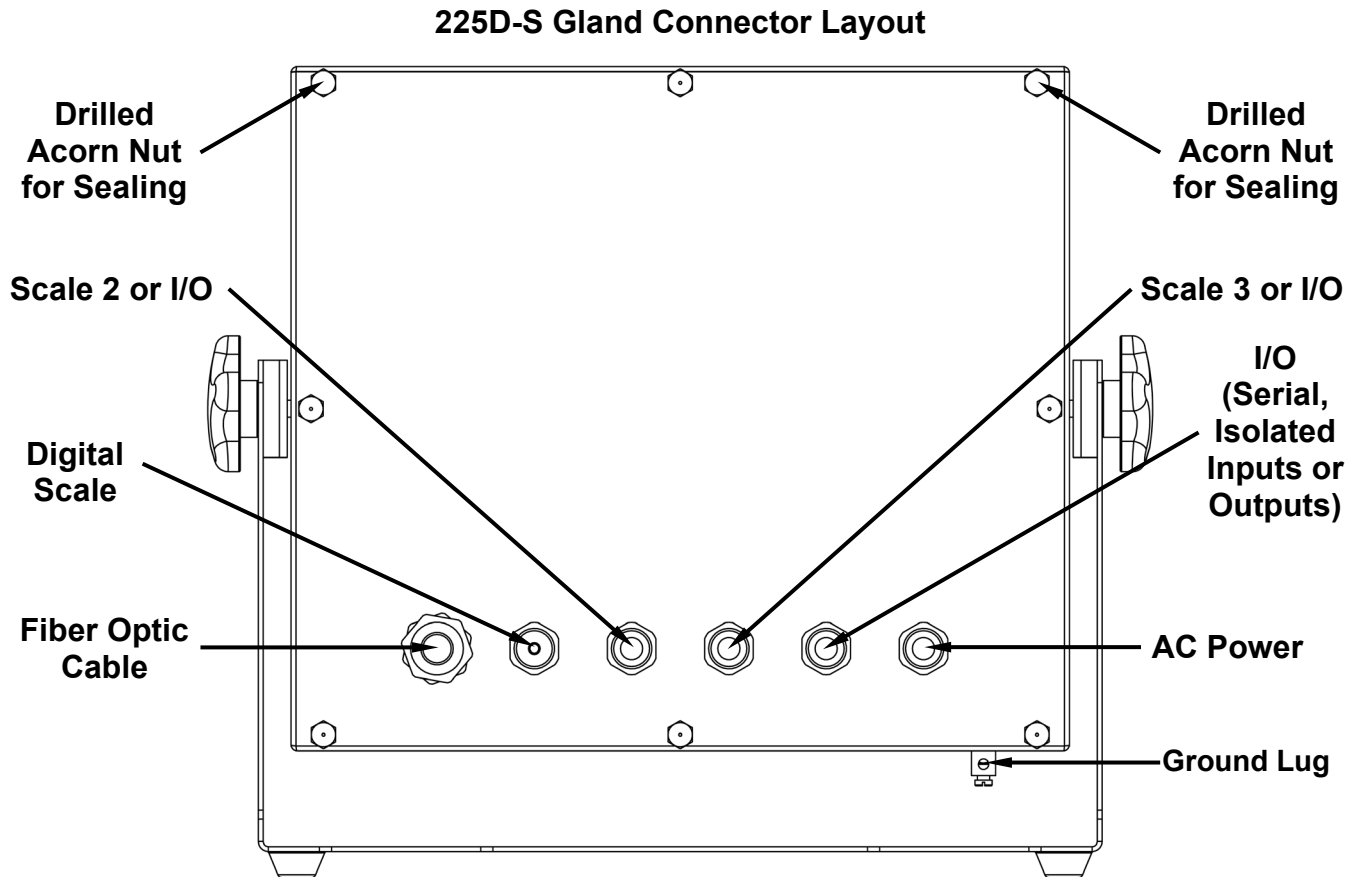

Figure No. 5



ATTENTION! OBSERVE PRECAUTIONS FOR HANDLING ELECTROSTATIC SENSITIVE DEVICES!

1. Referring to Figure No. 5, remove the 8 acorn nuts securing the rear panel to the front enclosure, and remove the rear panel.
2. Loosen and remove the metal gland connector nut, then take out the plastic insert.
3. Route the homerun cable through the nut and plastic insert and into the enclosure.
4. Proceed to Step 5 on Page 11 to complete installing the homerun cable.

HOMERUN CABLE INSTALLATION, CONT.

POWER-DLC to 225D Indicator Connection, Cont.

5. With the homerun cable routed into the enclosure, referring to Figure No. 6, remove approximately 2.0 inches (51 mm) of the cables' outer jacket, exposing the internal wires.
6. Next, remove approximately 1/4 inch (6 mm) of insulation from each of the five wires.

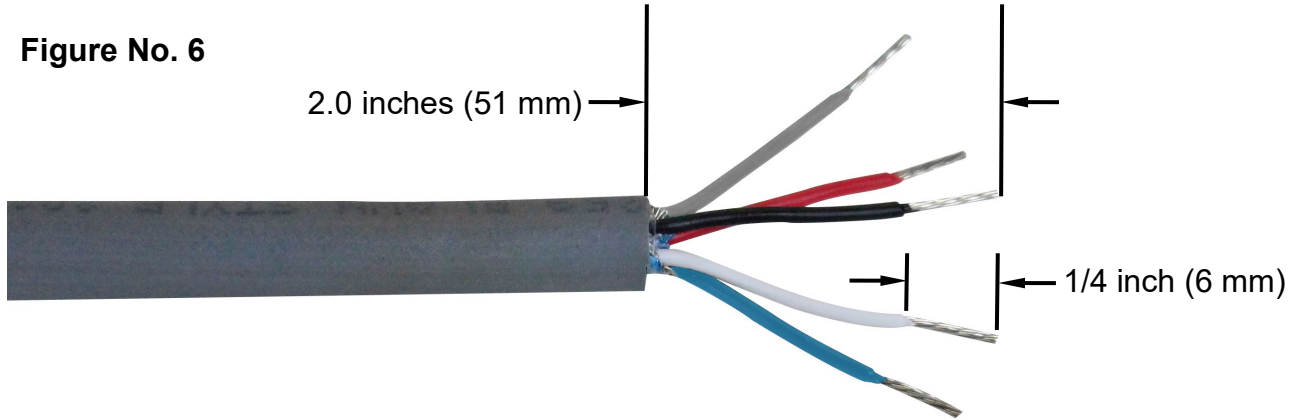

7. Referring to the table below (or on the circuit board) for terminal connections, connect each wire to the P5 terminal block on the 195/225-DLC controller card.

Homerun Cable Connection to P5 Terminal Block

Board Label	Homerun Cable Wire Color	Wire Color if using a Load Cell Cable
V-BUS	BLACK	BLUE
CAN L	BLUE or LIGHT BLUE	GRAY
SHIELD	GRAY	BROWN
CAN H	WHITE	BLACK
V+BUS	RED	WHITE

8. Referring to Figure No. 7, use a small flat-blade screwdriver to press down on the release for the terminal, insert the wire into the opening, and then remove the screwdriver. The release will return to its original position, locking the wire in place.

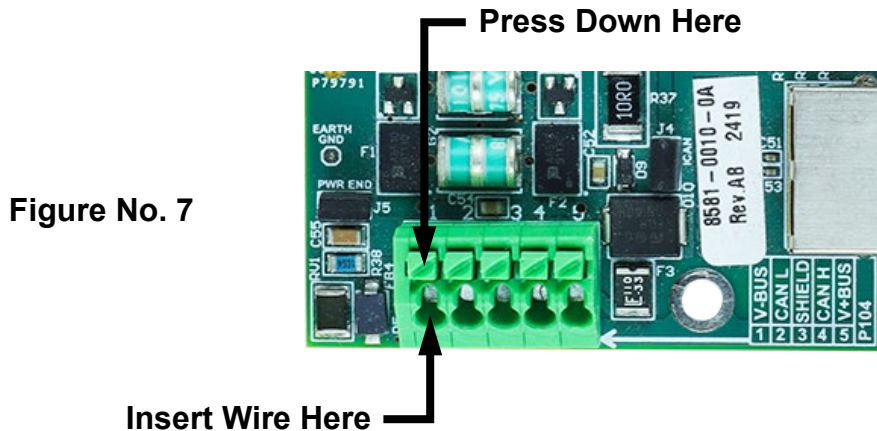

HOMERUN CABLE INSTALLATION, CONT.

POWER-DLC to 225D Indicator Connection, Cont.

9. Repeat steps 7 and 8 until all five wires of the homerun cable are installed in the P5 terminal block on the 195/225-DLC controller card.
10. After all terminations have been made, remove the excess homerun cable from the indicator enclosure.
11. Insert the plastic insert into the metal gland connector, and finger-tighten the metal gland connector nut and each of the black gland connectors.
12. Ensure any unused gland connectors are plugged, and any other excess cable has been removed from the indicator enclosure. Securely tighten each of the cable gland connectors.
 - Do not overtighten the gland connectors, but make certain they are snug.
13. Completing the indicator homerun cable connection is dependent on the indicator model:

225D-D Desktop Indicator:

Close the front panel by lifting it until it is against the main enclosure, and then secure the front panel to the main enclosure with the 2 thumbscrews removed earlier.

225D-S Stainless Steel Indicator:

Replace the rear panel and secure it to the front enclosure with the 8 acorn nuts removed earlier. Securely tighten the acorn nuts with a 3/8 in wrench or ratchet and 3/8 in socket. Follow a diagonal pattern when tightening the acorn nuts.

HOMERUN CABLE INSTALLATION, CONT.

POWER-DLC to Load Cell Connection

The main (longer) section of the Homerun Cable is connected to the first load cell in the loop (the Start Node) and the SCALE terminal block in POWER-DLC. It is made from five conductors, shielded PVC cable, and terminated with the *included* 5-pin actuation lever-type connector from the Homerun Cable Connector Pack. Refer to the table below for cable and connector information.

Cable and Connector Information Table

ITEM and DESCRIPTION	CARDINAL PART NO.
HOMERUN CABLE, 5 CONDUCTORS, SHIELDED PVC (CONTAINS 2 x 18AWG, 2 x 22AWG, AND 1 x 22AWG)	6980-1092
CONNECTOR PACK, HOME RUN CABLE (INCLUDES 5-PIN SPRING CAGE CONNECTOR, 6610-1258)	3502-0681-0A
RECOMMENDED HOMERUN CABLE BELDEN 5303FE, 18 AWG, 5 CONDUCTORS	SUPPLIED BY DEALER



IMPORTANT: Clean the load cell connectors and the homerun connector plug with electrical contact cleaner, and then apply dielectric grease to the homerun connector plug before installing it into the load cell connector.

1. Disassemble the connector (unscrew the black plastic part of the connector from the metal part), and then slide the black plastic part onto the homerun cable. See Figure No. 8.

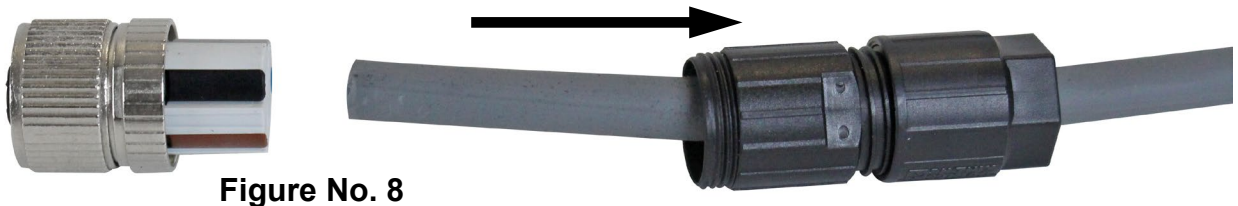

Figure No. 8

2. With the homerun cable routed through the black plastic part of the connector, remove approximately 1 inch (25 mm) of the cable's outer jacket, exposing the internal wires.
3. Next, referring to Figure No. 9, remove approximately 5/16 inches (8 mm) of insulation from each of the five wires. **NOTE:** The hex part of the black plastic cable clamp is approximately 5/16 inches (8 mm) and can be used as a guide for stripping the wires.

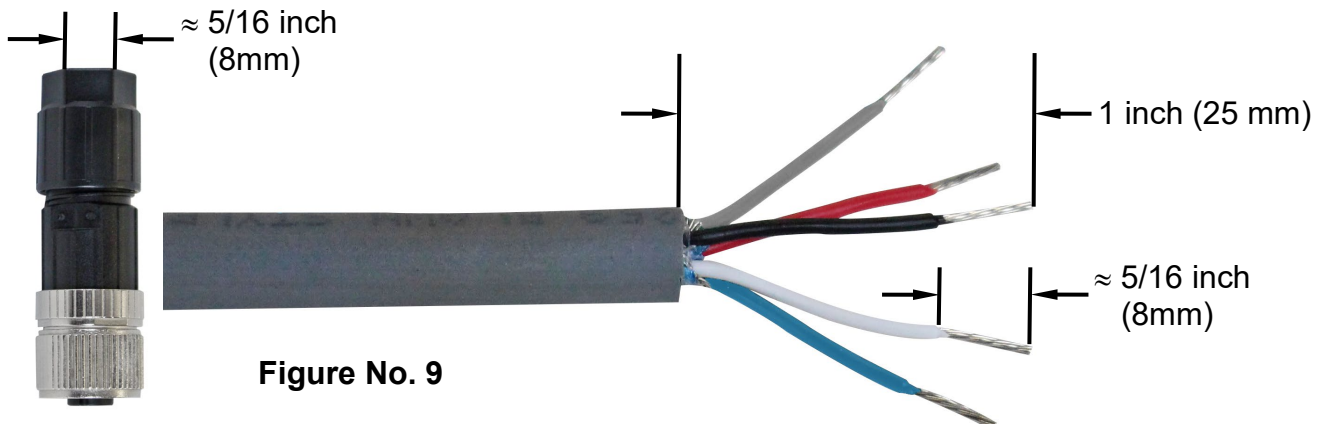

Figure No. 9

HOMERUN CABLE INSTALLATION, CONT.

POWER-DLC to Load Cell Connection, Cont.



IMPORTANT! Refer to the Homerun Connector Wiring Color Code Table below when performing steps 4 through 7.

Homerun Connector Wiring Color Code Table

Connector Pin Number	Connector Lever Color	Signal	Homerun Cable Wire Color	Wire Color if using a Load Cell Cable
1	BROWN	SHLD	GRAY	BROWN
2	WHITE	V+BUS	RED	WHITE
3	BLUE	V-BUS	BLACK	BLUE
4	BLACK	CAN H	WHITE	BLACK
5	GRAY	CAN L	BLUE or LIGHT BLUE	GRAY

Refer to Figure No. 10 below when performing steps 4, 5, and 6.

4. Looking at the end of the metal part of the connector where the wires are inserted, use your fingernail and gently pull a wire clamp lever down away from the body of the connector.
5. Insert the wire into the appropriate connector opening, and then close the wire clamp lever.
6. Verify that the wire is being held securely in the connector by lightly pulling on the wire.

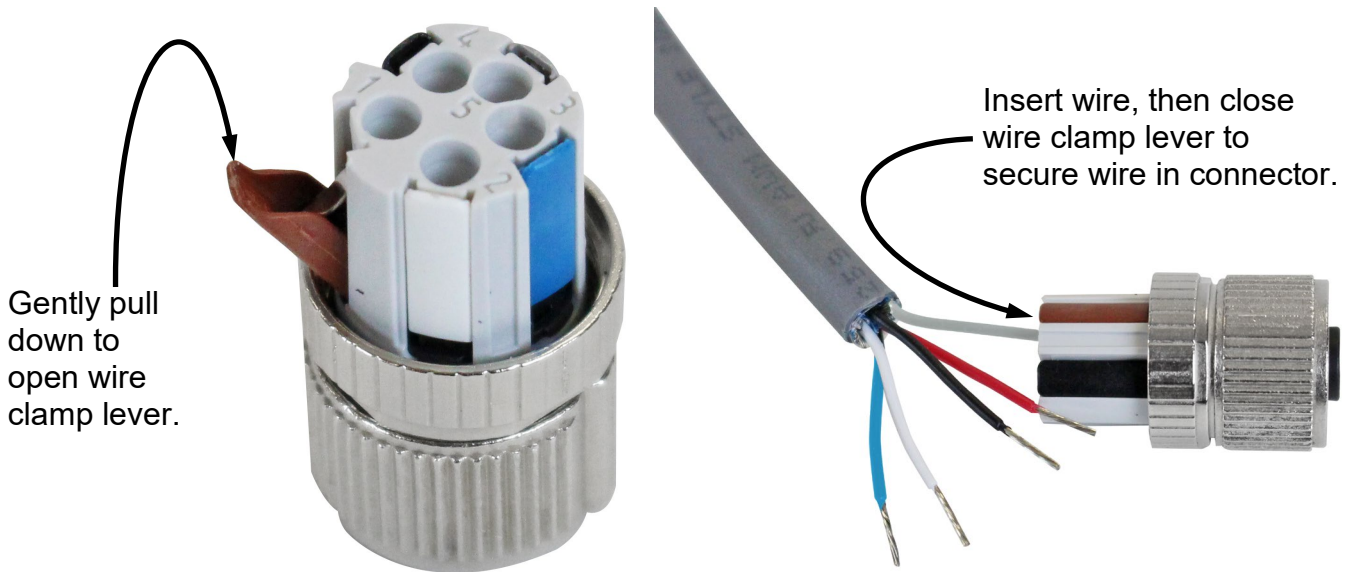

Figure No. 10

7. Repeat steps 4 through 6 until all five wires of the homerun cable are installed in the metal part of the connector.

HOMERUN CABLE INSTALLATION, CONT.

POWER-DLC to Load Cell Connection, Cont.

8. After all connections have been made, slide the black plastic and metal connector parts together, then hand-tighten to screw them together. See Figure No. 11.

Figure No. 11



9. Referring to Figure No. 12, complete the assembly by holding both the black and metal parts of the connector housing, then hand-tightening the cable clamp to the black plastic part of the connector housing.

Figure No. 12

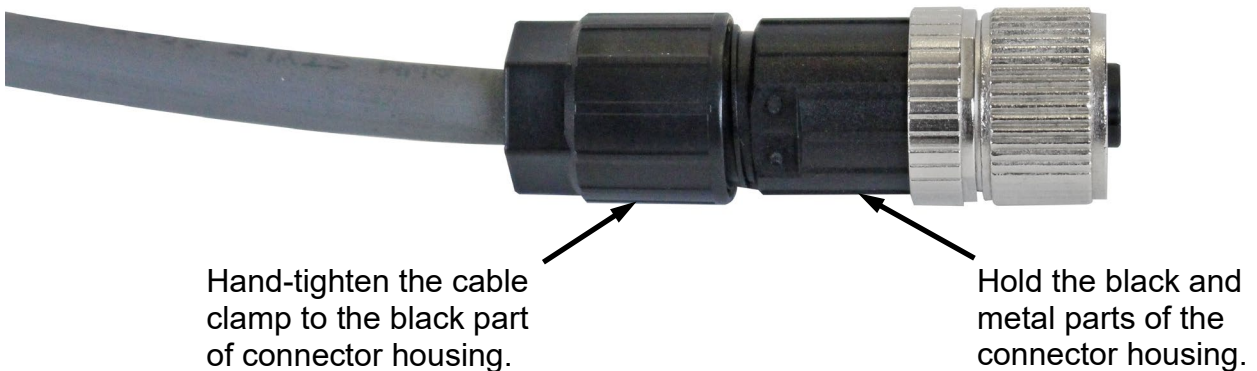

10. **NOTE:** The image in Figure No. 13 shows the cable clamp separated from the connector housing to illustrate the cable clamp collar.

Figure No. 13

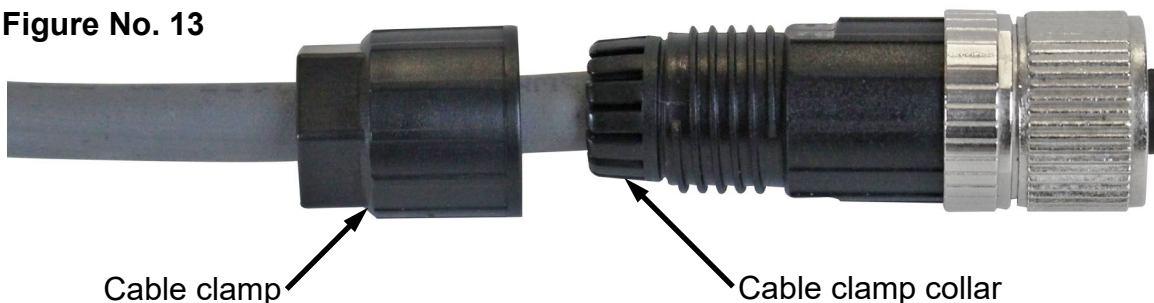

SETUP AND CONFIGURATION

All digital scales using Cardinal Scale's SCBD SmartCell® or DC digital load cells are connected with a daisy-chained CAN (Controller Area Network) cable. The load cell connection loop can begin at any load cell and may continue clockwise as shown or counter-clockwise if preferred. Note that in the tank/hopper example below (Figure No. 14), there is no connection between cells 1 and 2, and in the truck scale example (Figure No. 15), there is no connection between cells 4 and 6.

NOTE: Be sure to insert the end node termination plug on the load cell at the end of the loop as shown in both examples.

Example: Typical Tank/Hopper Configuration

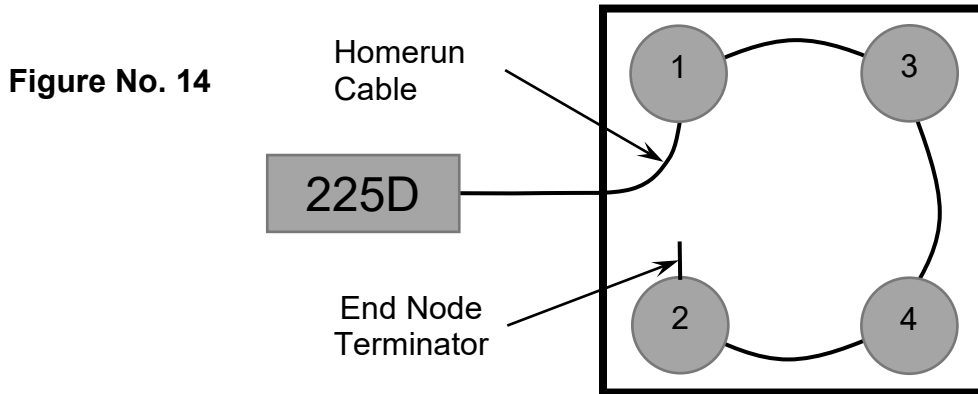

NOTE: If the loop were run in the other direction, the sequence would then be 2-4-3-1 with load cell 1 having the End Node Terminator installed on it.

Example: Typical Truck Scale Configuration

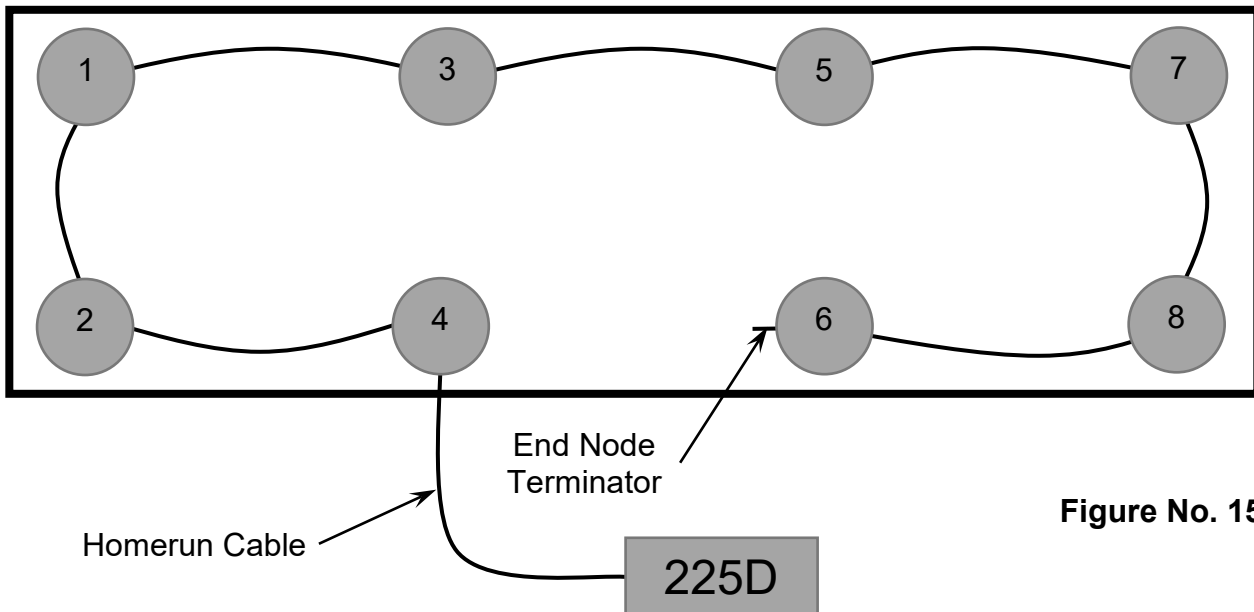

Figure No. 15

NOTE: If the loop were run in the other direction, the sequence would then be 6-8-7-5-3-1-2-4 with load cell 4 having the End Node Terminator installed on it.

SETUP AND CONFIGURATION, CONT.

The Setup and Configuration of the 225D indicator is accomplished entirely by the keypad. However, it may require changing the position of the calibration inhibit jumper (P4) depending on the method of sealing required by your local metrology laws.

The calibration inhibit jumper (P4) is located on the main printed circuit board. Access to this jumper is obtained differently depending on the indicator model:

- **225D-D Desktop Indicator:**
Remove the 2 thumbscrews securing the front panel to the rear enclosure, and then lower the front panel.
- **225D-S Stainless Steel Indicator:**
Remove the 8 acorn nuts securing the rear panel to the front enclosure, and remove the rear panel.

During the setup and configuration process, it is necessary to enter operational parameters and data using the indicator keypad.

- Pressing the **ENTER** key without entering a new value will retain the current setting and return the display to the menu display.
- To change a setting, enter or select a new value and then press the **ENTER** key. The new setting will be saved, and the display will return to the menu display.
- Note that pressing the **ESC/←** key on YES or NO prompts will return to the previous selection. Also note that on prompts requiring a value to be entered, pressing the **ESC/←** key will clear the value.

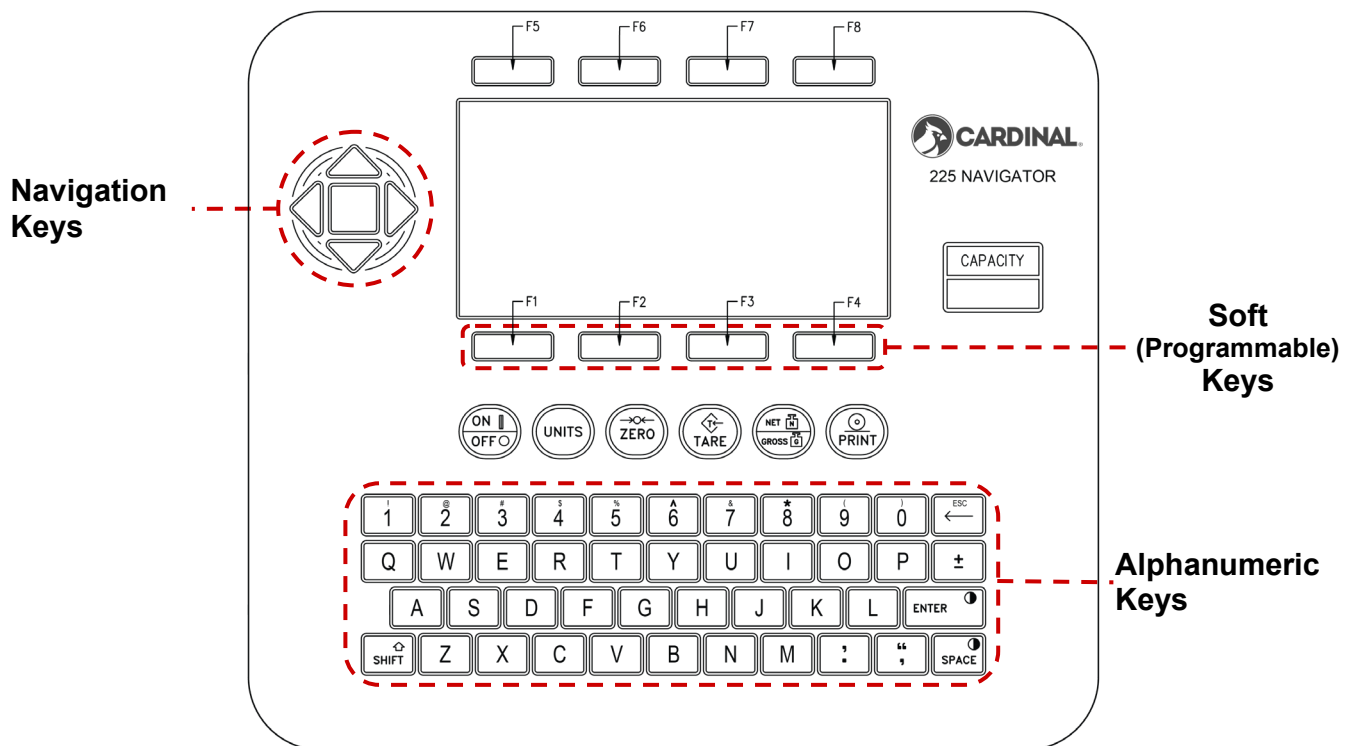
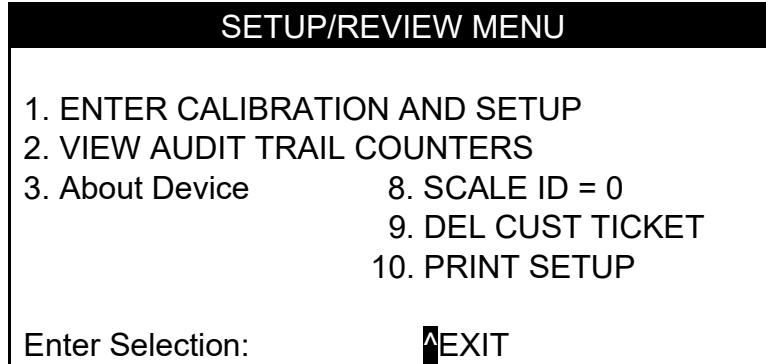

Figure No. 16

SETUP AND CONFIGURATION, CONT.

To Begin Setup and Configuration

With the indicator ON, press and hold the **SHIFT** key and then press the **ENTER** key or the Navigation **ENTER** key (red square key in the center of the Navigation arrows). The display will change to show the SETUP/REVIEW MENU.



1. ENTER CALIBRATION AND SETUP

SETUP MENU #1

With the SETUP/REVIEW MENU displayed, press the **1** key and then the **ENTER** key. The display will change to show SETUP MENU #1.

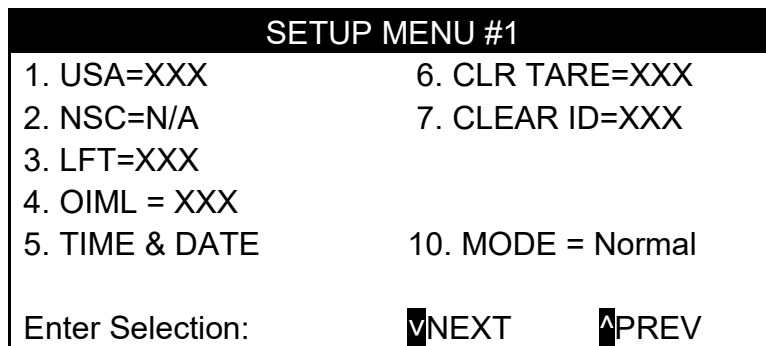

SETUP MENU #2

With Setup Menu #1 displayed, press **NEXT** (Navigation Keys Down Arrow) to proceed to SETUP MENU #2.

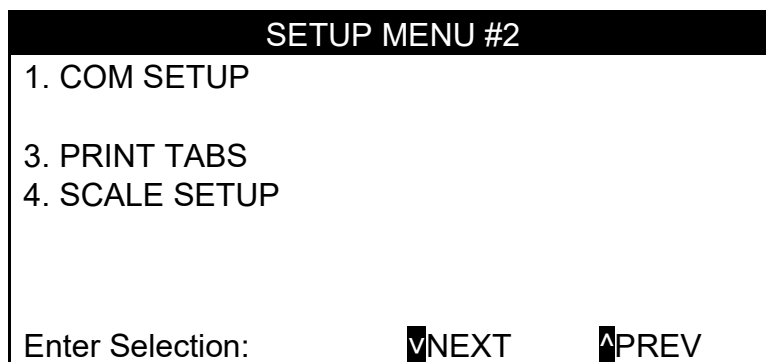

SETUP AND CONFIGURATION, CONT.

4. SCALE SETUP

With the SETUP MENU #2 displayed, press the **4** key and then the **ENTER** key to proceed to the SCALE SETUP menu.

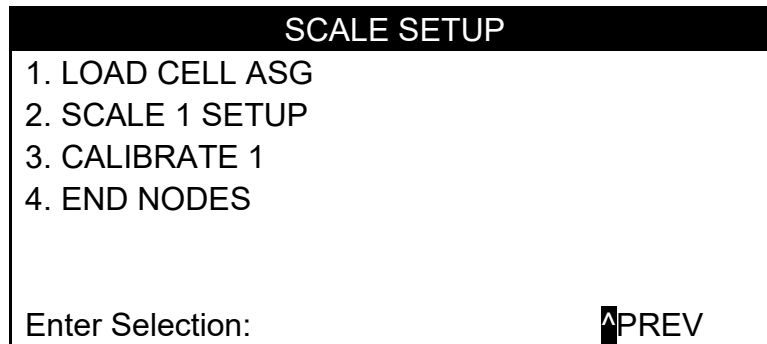

1. LOAD CELL ASG (LOAD CELL ASSIGNMENTS)

Each cell has a serial number (S/N) marked on the cell. This is an eight-digit hexadecimal number. It is also known as the cell ID. Each cell ID must be matched with a scale.

With the SCALE SETUP menu displayed, press the **1** key and then the **ENTER** key to proceed to the LOAD CELL ASSIGNMENTS menu.

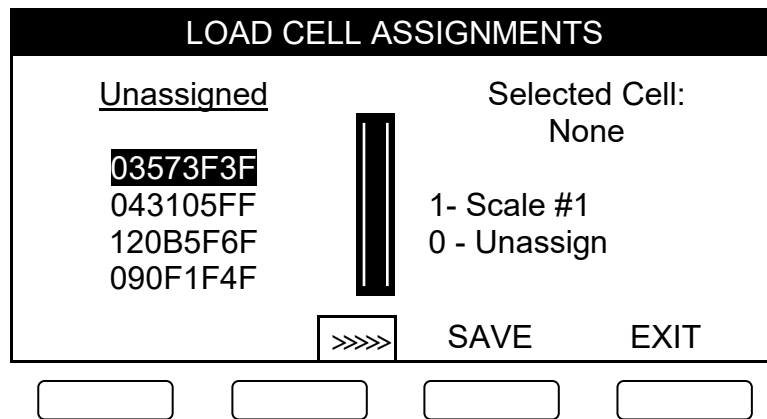

With the LOAD CELL ASSIGNMENTS menu displayed, the display will show the detected unassigned load cell IDs on the left column under the Unassigned heading.

To view assigned load cell IDs and the scale number assigned, press the **>>>>** soft key (or the Navigation Keys **▷** Right Arrow). The display will change to show the existing programmed IDs and the scale number assigned for each cell in the left column under the Scale # heading.

Press the **<<<<** soft key (or the Navigation Keys **◁** Left Arrow) to return to the unassigned load cell IDs display.

SETUP AND CONFIGURATION, CONT.

1. LOAD CELL ASG (LOAD CELL ASSIGNMENTS), Cont.

With the LOAD CELL ASSIGNMENTS menu displayed, use the Navigation Keys (▽ Down and △ UP Arrows) to select (highlight) a specific cell from the left unassigned column, and then press the **1** key to move the ID to the right Selected Cell: column.

NOTE: To unassign a specific cell, press the **0** key to move it from the Selected Cell column back to the left unassigned column.

Select (highlight) the next cell, then press the **ENTER** key to move the ID to the right Selected Cell: column. Repeat this process until all cell IDs have been assigned to the scale.

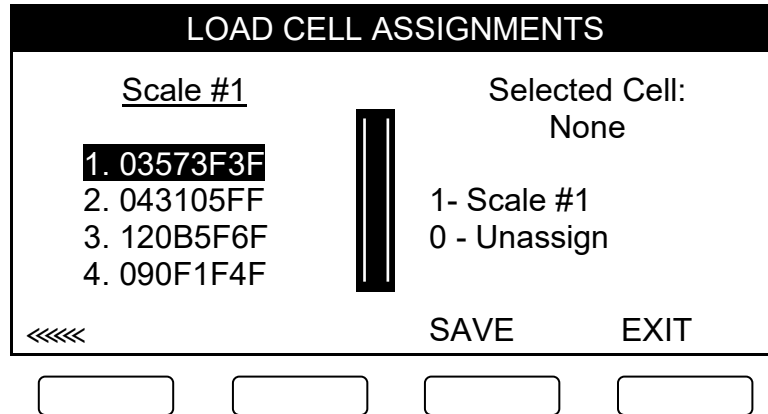

With the LOAD CELL ASSIGNMENTS menu displayed, press the >>>> soft key (or Navigation Keys ▷ Right Arrow). The display will change to show the existing programmed load cell IDs and the scale number assigned for each cell in the left column under the Scale # heading.

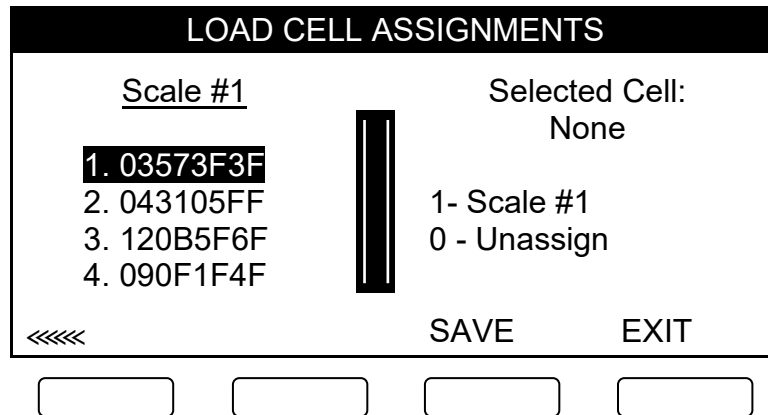

Press **SAVE** to save the cell assignments. The display will show SAVING CHANGES for a few seconds and then return to the SCALE SETUP menu.

SETUP AND CONFIGURATION, CONT.

4. END NODES

The 225D indicator also needs to know where the scale starts and ends. The START NODE is the cell that connects to the 225D. The END NODE is the last cell in the daisy chain.

- In the typical tank/hopper example, the START NODE is #1, and the END NODE is #2.
- In the typical truck scale example, the START NODE is #4, and the END NODE is #6.

With the SCALE SETUP menu displayed, press the **4** key and then the **ENTER** key to proceed to the END NODES menu.

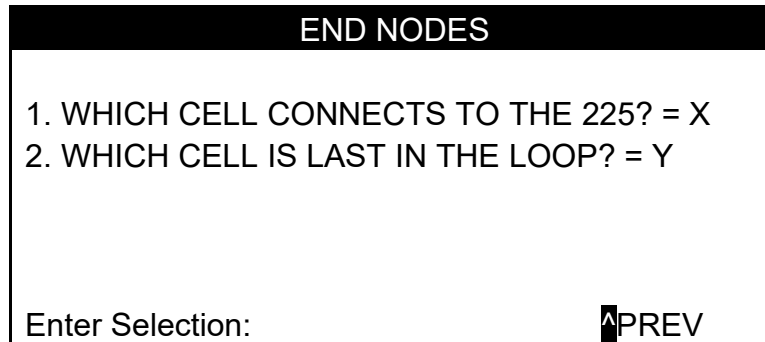

The screenshot shows a rectangular display with a black header bar containing the text "END NODES" in white. Below the header, the display shows two numbered questions: "1. WHICH CELL CONNECTS TO THE 225? = X" and "2. WHICH CELL IS LAST IN THE LOOP? = Y". At the bottom left of the display, it says "Enter Selection:". At the bottom right, there is a small icon of an upward-pointing arrow followed by the text "PREV".

START NODE (First in the Loop)

With the END NODES menu displayed, press the **1** key, then press the **ENTER** key. The display will change to show: FIRST IN THE LOOP?.

Using the numeric keys, enter a new value for the START NODE (First in the Loop), then press the **ENTER** key to save the new setting.

Example: Referring to the previous typical configuration examples, the user would enter **1** (for the Tank/Hopper) or **4** (for the Truck Scale), then press the **ENTER** key.

END NODE (Last in the Loop)

With the END NODES menu displayed, press the **2** key, then press the **ENTER** key. The display will change to show LAST IN THE LOOP?.

Using the numeric keys, enter the new value for the END NODE (Last in the Loop), then press the **ENTER** key to save the setting.

Example: Referring to the previous typical configuration examples, the user would enter **2** (for the Tank/Hopper) or **6** (for the Truck Scale), then press the **ENTER** key.

Press **PREV** (Navigation Keys Δ UP Arrow) to return to the SCALE SETUP menu.

SETUP AND CONFIGURATION, CONT.

Calibration

If, after test loading the scale, it is determined that adjustments are required, follow the procedure below. Note that this section describes the procedure necessary to calibrate a Digital Truck Scale.

1. Before any adjustments are made, turn on the power to the 225D indicator.
2. Drive a test truck across the scale **at least three times** in each direction before calibrating the scale.
3. Before sealing can be done, the 225D indicator must be calibrated to the scale. A division size of 10 lbs. should be selected and the auto-zero function turned off. Refer to the standard Model 225 Desktop Weight Indicator Installation and Technical Manual (8200-0870-0M) and the Model 225 Stainless Steel Weight Indicator Installation and Technical Manual (8200-0873-0M) for details on division size and auto-zero function.

All digital cells are pre-calibrated in the factory for span. That means that span calibration is not necessary to start making weights. Only a zero calibration is necessary. However, a Smart Calibration is still usually necessary to trim the corners and sections of a scale.

3. CALIBRATE 1

With the SCALE SETUP menu displayed, press the **3** key and then the **ENTER** key to proceed to the SCALE 1 CALIBRATION menu.

SCALE 1 CALIBRATION	
1. SMART CAL	
2. ZERO CAL	
3. TRIM CELLS	
4. SPAN ADJUST	
Enter Selection:	▲PREV

SCALE 1 CALIBRATION

With the SCALE 1 CALIBRATION menu displayed, press the **1** key and then the **ENTER** key. The display will change to show the SMART CAL screen.

SMART CAL	
Current Cell:	Not Yet Started
Enter calibration weight and then press ENTER to get started	
Calib Weight:	0

SETUP AND CONFIGURATION, CONT.

SMART CALIBRATION

Smart Calibration is not necessary to make weight, but it is helpful for trimming all load cells automatically.



IMPORTANT! For scales with more than four load cells and an even total number of load cells (such as an eight-cell scale), the calibration pattern is:

- Odd-numbered load cells in ascending order
- Then, the even-numbered load cells in descending order

This pattern facilitates easier movement of the weight cart.

Example (8-cell scale):

1, 3, 5, 7, 8, 6, 4, 2

When a scale has four load cells or fewer (such as a tank scale), the calibration pattern will be sequential.

Example (4-cell scale):

1, 2, 3, 4

1. SMART CAL (SMART CALIBRATION)

With the SMART CAL screen displayed, the prompt to enter the value of the Calibration Weight (test weight) will be shown.

Using the numeric keys, enter the value for the test weight, and then press the **ENTER** key.

SMART CAL	
Current Cell:	Not Yet Started
Enter calibration weight and then press ENTER to get started	
Calib Weight:	XXXXX

The 225D display will change to prompt you to confirm that the scale is empty.

SMART CAL	
Current Cell:	
Remove all weight from the scale and then press ENTER to continue	

Ensure the scale is empty, and then press the **ENTER** key. This will capture the calibrated dead load weight (empty weight) of the scale.

SETUP AND CONFIGURATION, CONT.

1. SMART CAL (SMART CALIBRATION), Cont.

The 225D display will flash “Calibrating...” several times to indicate it is calculating the empty weight (dead-load weight) of the scale and then prompt you to place a weight on load cell 1.

SMART CAL	
Current Cell:	#01 ID: 03573F3F
Place calibration weight on cell #01 and then press ENTER to continue	

Center the weight over load cell 1 on the scale, and then press the **ENTER** key.

The 225D display will flash “Calibrating...” several times to indicate it is calculating the weight on load cell 1 and then prompt to place the weight over load cell 3.

SMART CAL	
Current Cell:	#03 ID: 043105FF
Place calibration weight on cell #03 and then press ENTER to continue	

Move the weight over load cell 3 on the scale, and then press the **ENTER** key.

The 225D display will flash “Calibrating...” several times to indicate it is calculating the weight on load cell 3 and then prompt to place the weight over load cell 5.

SMART CAL	
Current Cell:	#05 ID: 090F1F4F
Place calibration weight on cell #05 and then press ENTER to continue	

Move the weight over load cell 5 on the scale, and then press the **ENTER** key.

SETUP AND CONFIGURATION, CONT.

1. SMART CAL (SMART CALIBRATION), Cont.

The 225D display will flash “Calibrating...” several times to indicate it is calculating the weight on load cell 5 and then prompt to place the weight over load cell 7.

SMART CAL	
Current Cell:	#07 ID: 1A6EBA8F
Place calibration weight on cell #07 and then press ENTER to continue	

Move the weight over load cell 7 on the scale, and then press the **ENTER** key.

The 225D display will flash “Calibrating...” several times to indicate it is calculating the weight on load cell 7 and then prompt to place the weight over load cell 8.

SMART CAL	
Current Cell:	#08 ID: 1AD620CF
Place calibration weight on cell #08 and then press ENTER to continue	

Move the weight over load cell 8 on the scale, and then press the **ENTER** key.

The 225D display will flash “Calibrating...” several times to indicate it is calculating the weight on load cell 8 and then prompt to place the weight over load cell 6.

SMART CAL	
Current Cell:	#06 ID: 120B5F6F
Place calibration weight on cell #06 and then press ENTER to continue	

Move the weight over load cell 6 on the scale, and then press the **ENTER** key.

SETUP AND CONFIGURATION, CONT.

1. SMART CAL (SMART CALIBRATION), Cont.

The 225D display will flash “Calibrating...” several times to indicate it is calculating the weight on load cell 6 and then prompt to place the weight over load cell 4.

SMART CAL	
Current Cell:	#04 ID: 0561A95F
Place calibration weight on cell #04 and then press ENTER to continue	

Move the weight over load cell 4 on the scale, and then press the **ENTER** key.

The 225D display will flash “Calibrating...” several times to indicate it is calculating the weight on load cell 4 and then prompt to place the weight over load cell 2.

SMART CAL	
Current Cell:	#02 ID: 02259BFF
Place calibration weight on cell #02 and then press ENTER to continue	

Move the weight over load cell 2 on the scale, and then press the **ENTER** key.

The 225D display will flash “Calibrating...” several times to indicate it is calculating the weight on load cell 2 and then return to the SCALE 1 CALIBRATION menu, indicating the Smart Calibration is complete.

SETUP AND CONFIGURATION, CONT.

2. ZERO CAL (ZERO CALIBRATION)

With the SCALE 1 CALIBRATION menu displayed, press the **2** key and then the **ENTER** key. The display will change to show the ZERO CAL screen.

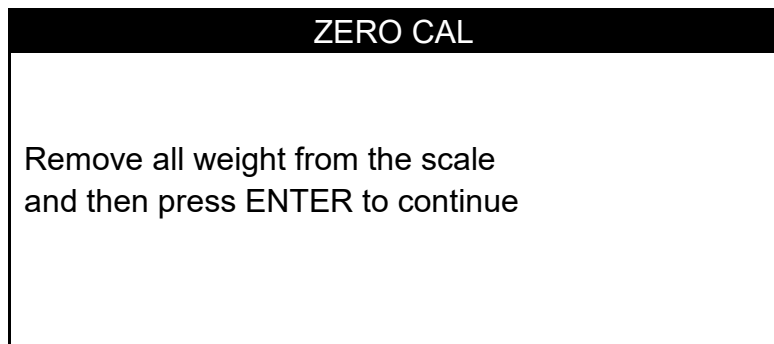

Ensure the scale is empty, and then press the **ENTER** key. Note that Zero Calibration does not affect the trimming of the cells or affect span; it simply sets the dead load weight of the scale.

The 225D display will flash “Calibrating...” several times to indicate it is calibrating zero, and then return to the SCALE 1 CALIBRATION menu, indicating the Zero Calibration is complete.

3. TRIM CELLS (TRIM LOAD CELLS)

With the SCALE 1 CALIBRATION menu displayed, press the **3** key and then the **ENTER** key. The display will change to show the TRIM CELLS screen.

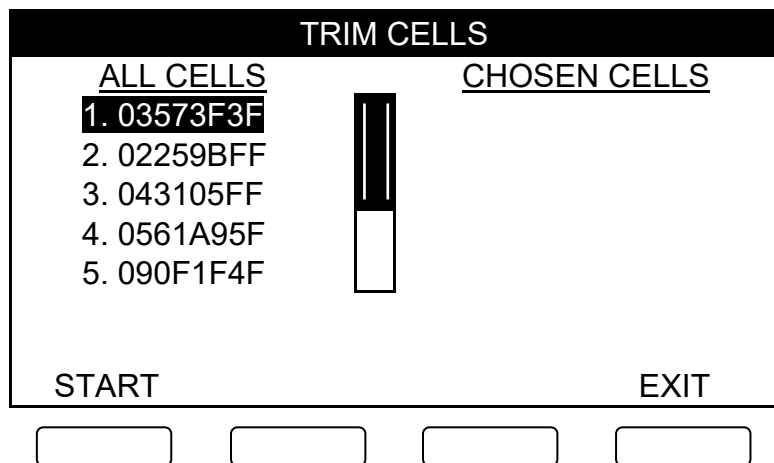

Individual cells or scale sections (pairs of cells) may be trimmed.

NOTE: This requires a test load weight.

SETUP AND CONFIGURATION, CONT.

3. TRIM CELLS (TRIM LOAD CELLS), Cont.

Single Cell Trim

With the TRIM CELLS screen displayed, use the Navigation Keys (▽ Down and △ UP Arrows) to select (highlight) a specific cell from the left ALL CELLS column, and then press the **ENTER** key to move the ID to the right CHOSEN CELLS column.

Scale Section Trim (Pair of Cells)

With the TRIM CELLS screen displayed, use the Navigation Keys (▽ Down and △ UP Arrows) to select (highlight) the first cell from the left ALL CELLS column, and then press the **ENTER** key to move the ID to the right CHOSEN CELLS column. Repeat the operation to select the second cell.

Press the **START** soft key. The display will change to show the following screen.

TRIM CELLS			
TRIM		CHOSEN CELLS	
#01	0.997449	1.	03573F3F
#03	1.5836519	3.	043105FF
Total Weight :10000			
Set Weight	Default	More	EXIT

Set Weight

1. Place a test weight over the cell(s) to be adjusted.
2. Press the **Set Weight** soft key set the weight to adjust trim.
3. The display will change to show: TEST WEIGHT:.
4. Using the numeric keys, enter the actual correct weight of the test weight, and press the **ENTER** key.
5. The display will change to show “Please Wait, Auto Trimming” and automatically trim the cell(s) to get close to the entered test weight.

Default

Press the **Default** soft key to set the selected load cell as the default.

SETUP AND CONFIGURATION, CONT.

3. TRIM CELLS (TRIM LOAD CELLS), Cont.

More

The **More** soft key can be used to Coarse adjust (UP/DOWN) or Fine adjust (Fine Up/Fine Down) the trim value. The amount of weight that changes will depend upon several factors:

- Coarse (UP/DOWN) should be several grads
- Fine (Fine Up/Fine Down) should be less than a grad

With the TRIM CELLS screen displayed:

1. Press the **More** soft key once. The display will change to show:
 - **UP** – Press this soft key to increase the Coarse trim value.
 - **DOWN** – Press this soft key to decrease the Coarse trim value.
2. Press the **More** soft key again. The display will change to show:
 - **Fine Up** – Press this soft key to increase the Fine trim value.
 - **Fine Down** – Press this soft key to decrease the Fine trim value.
3. Press the **More** soft key a third time to return to the TRIM CELLS screen.

NOTE: If a single cell is selected, the trim value for that cell will be adjusted.

If a section is selected, the trim values for both cells will be adjusted.



IMPORTANT! AFTER ANY MANUAL TRIM VALUE CHANGES, A ZERO CALIBRATION SHOULD BE PERFORMED.

EXIT

With the TRIM CELLS screen displayed, press the **EXIT** soft key twice to return to the SCALE 1 CALIBRATION menu.

SETUP AND CONFIGURATION, CONT.

4. SPAN ADJUST (Adjust Scale Span)

Span adjust allows you to tweak the span of the entire scale at once. Note that the 225D will display the current live scale weight.

NOTE: This requires a test load weight.

With the SCALE 1 CALIBRATION menu displayed, press the **4** key and then the **ENTER** key. The display will change to show the SPAN ADJUST screen.

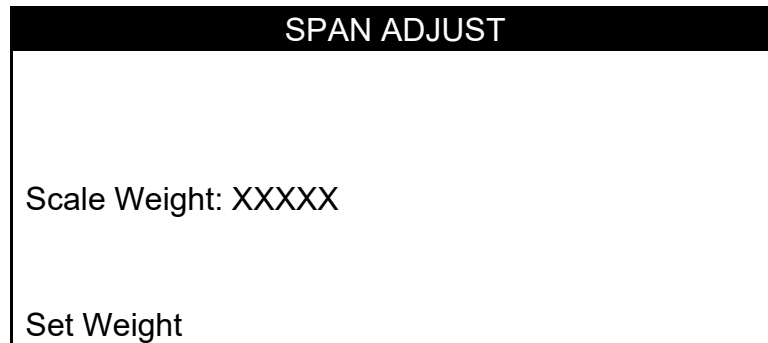

1. The display will show the current live scale weight, Scale Weight: XXXXX.X.

NOTE: High-resolution weight (interval/10) will be shown if the weight interval setting is less than 10. For example, an interval of 5 will be shown in 0.5 increments.

2. Place the test weight at any location on the scale.
3. Press the **Set Weight** soft key. The display will change to the prompt Test Weight:.



4. Enter the value of the test weight, and press the **ENTER** key.
5. The 225D will adjust the span to the target weight and return to the SPAN ADJUST screen.

Press Navigation Keys Δ UP Arrow to return to the SCALE 1 CALIBRATION menu.

Press **PREV** (Navigation Keys Δ UP Arrow) to return to the SCALE SETUP menu.

DIGITAL SCALE DIAGNOSTICS

There are four main components to 225D Digital Scale Diagnostics:

- **On-Screen Diagnostics** – Critical errors that alert the operator from the main screen of setup issues or hardware problems.
- **Cell Diagnostics** – A set of diagnostic tools that gives a technician more information about each load cell.
- **Hardware Diagnostics** – LEDs on the 195/225-DLC controller card alert technicians of the communications status.
- **iSite** – Web-based repository for historical load cell data that will be tracked for slow degradation of load cell integrity (for example, a single load cell that is drifting away from zero). iSite will also receive all the hardware errors found by the 225D Weight Indicator for Digital Scales.

On-Screen Diagnostics

The On-Screen Diagnostics messages are critical errors that alert the operator from the main screen to setup issues or hardware problems. These messages will be shown to the operator on the main weight screen in real-time when the error happens.

SCALE COMMUNICATIONS FAILURE



Probable Cause	Items to Check
The homerun cable is damaged or disconnected.	<ul style="list-style-type: none"> • Check that the cable is connected correctly. • Check the cable for damage. • Use caution on the amount of insulation stripped for the connector. The center wire could be shorted. It must be shorter than the center connector. • Check the connector for random strands of wire. • Verify that the connector is clear of debris.

DIGITAL SCALE DIAGNOSTICS, CONT.

On Screen Diagnostics, Cont.

COMMUNICATION ERROR BETWEEN LOADCELLS X AND Y

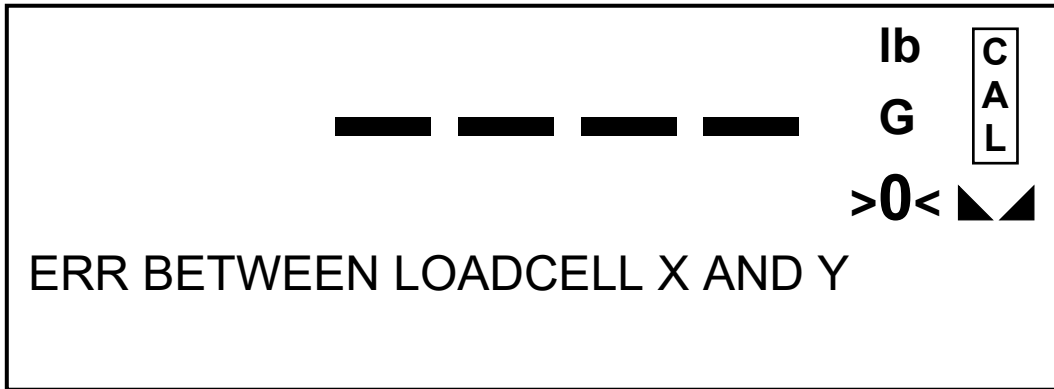

Probable Cause	Items to Check
There is a loss of communication between load cells.	<ul style="list-style-type: none"> • Check that the cable is connected correctly. • Check the cable for damage. • Verify that the connector is clear of debris. • Check the load cell COM ports on both load cells.

LOADCELLS NOT RESPONDING: #, #, #, #,

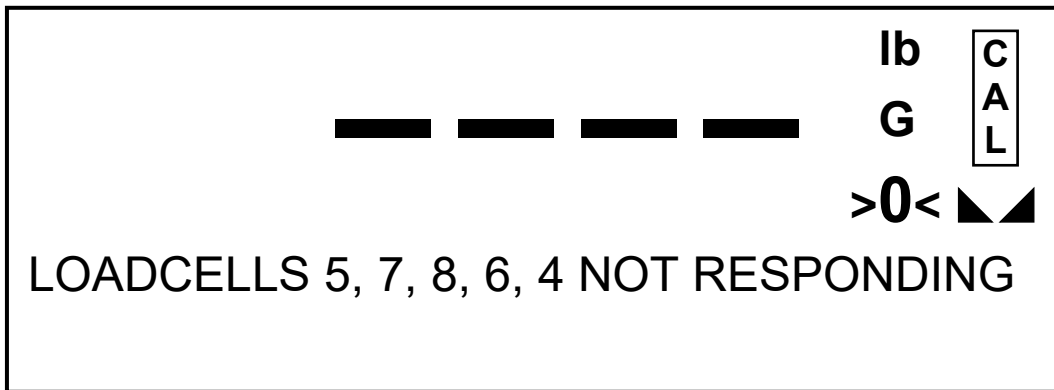

Probable Cause	Items to Check
The 225D cannot detect the exact communication problem with the unresponsive load cell.	<ul style="list-style-type: none"> • Check that the cable is connected correctly. • Check the cable for damage. • Verify that the connector is clear of debris. • Potentially dead load cell.

DIGITAL SCALE DIAGNOSTICS, CONT.

On Screen Diagnostics, Cont.

LOADCELL X DAMAGED



Probable Cause	Items to Check
There is irreparable internal damage to the load cell.	Replace the defective load cell.

LOADCELL X HAS BEEN REPLACED

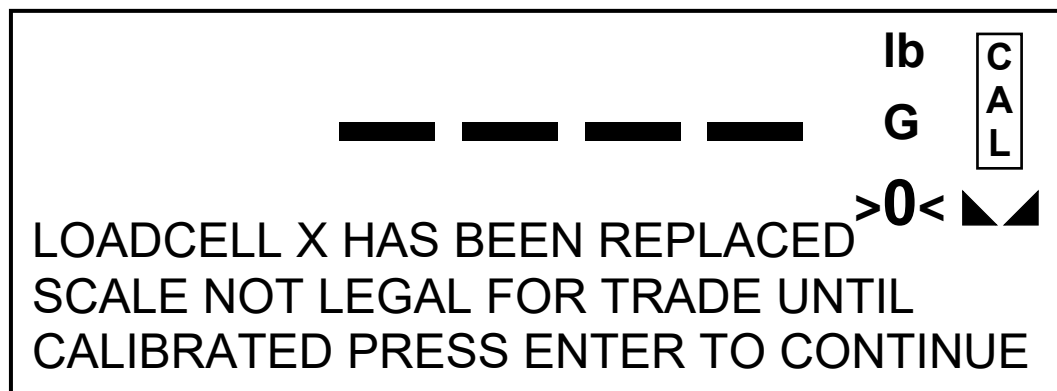

Probable Cause	Items to Check
A load cell has been replaced.	Replaced load cells are automatically detected if only one load cell was replaced. Once a load cell has been replaced, the 225D will auto-detect the new load cell, display the message that the scale is not Legal-For-Trade, and will need to be calibrated.

DIGITAL SCALE DIAGNOSTICS, CONT.

On Screen Diagnostics, Cont.

MORE LOAD CELLS THAN EXPECTED

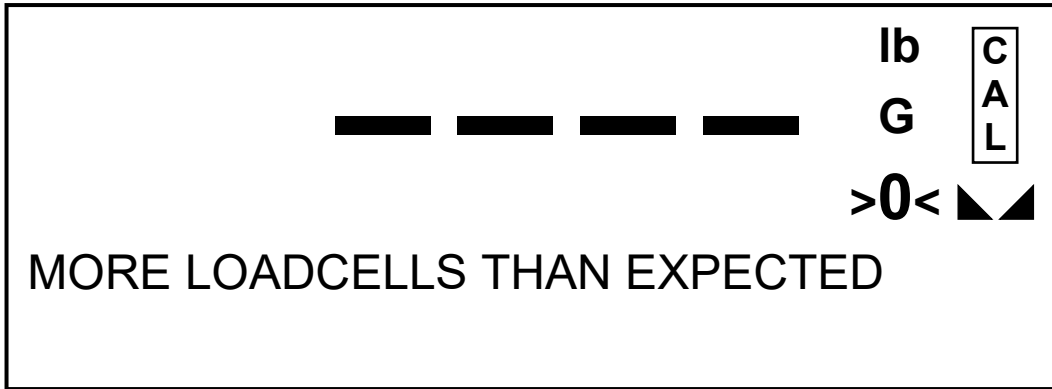

Probable Cause	Items to Check
There are more load cells than expected connected to the 225D. For example, the indicator number of load cells is set to 8, but the DLC controller detects there are 12 load cells.	Confirm and configure the number of load cells the scale should have.

LOAD CELL ID XXXXXXXX HAS NO ADDRESS

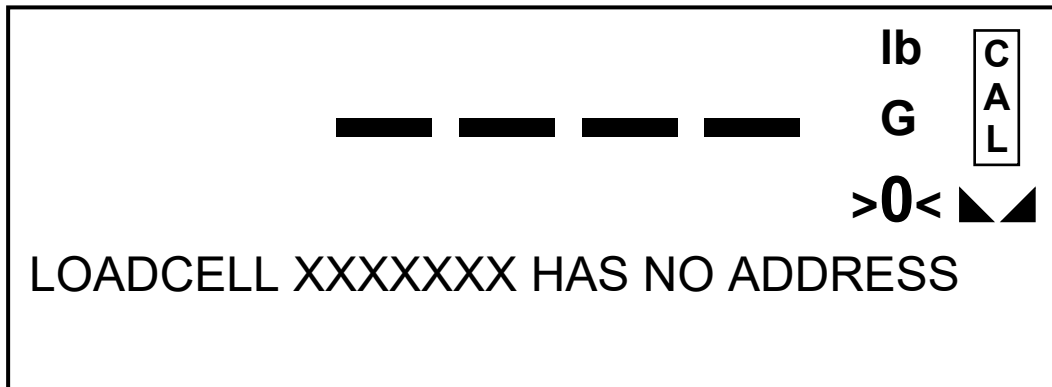

Probable Cause	Items to Check
A load cell is responding, but it is not addressed in the system.	Go to the addressing menu and assign the load cell ID to an address.

DIGITAL SCALE DIAGNOSTICS, CONT.

On Screen Diagnostics, Cont.

LOADCELL ADDRESS X NOT ASSIGNED TO SCALE

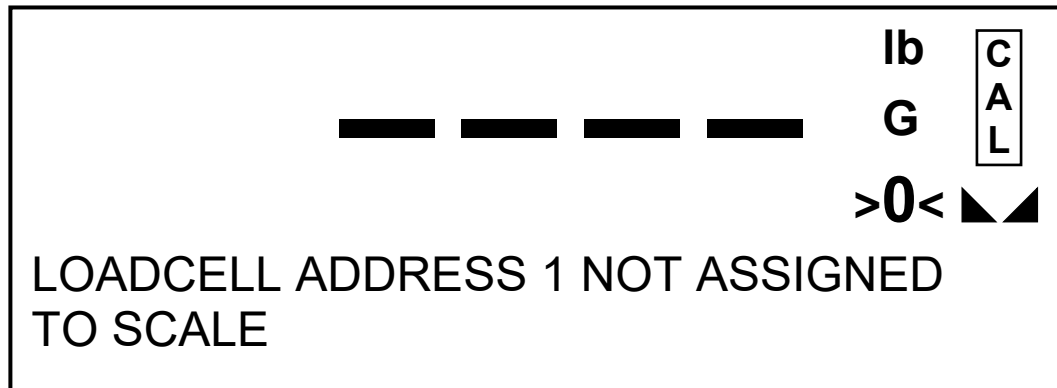

Probable Cause	Items to Check
A load cell has not been assigned to a scale.	Go to the addressing menu and assign a scale to the load cell.

LOW VOLTAGE ON LOAD CELL #, #, #, #, #, #, #,

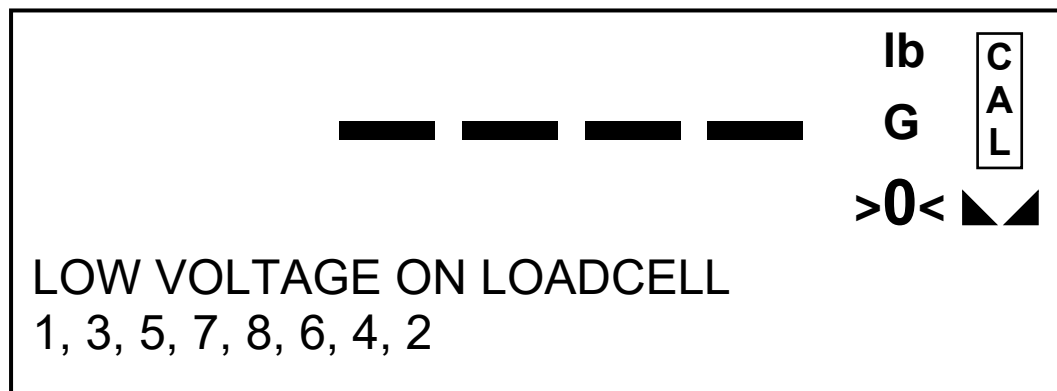

Probable Cause	Items to Check
Low power on a load cell. NOTE: Load cells at the end of the CAN daisy chain are most susceptible to low-voltage errors because of voltage drop along the cable.	<ul style="list-style-type: none"> • There are too many load cells on the chain. • Check that the cable is connected correctly. • Check the cable for damage. • Verify that the connector is clear of debris. • Check the 225D indicator power supply.

DIGITAL SCALE DIAGNOSTICS, CONT.

On Screen Diagnostics, Cont.

DIGITAL SCALE BOARD NOT DETECTED

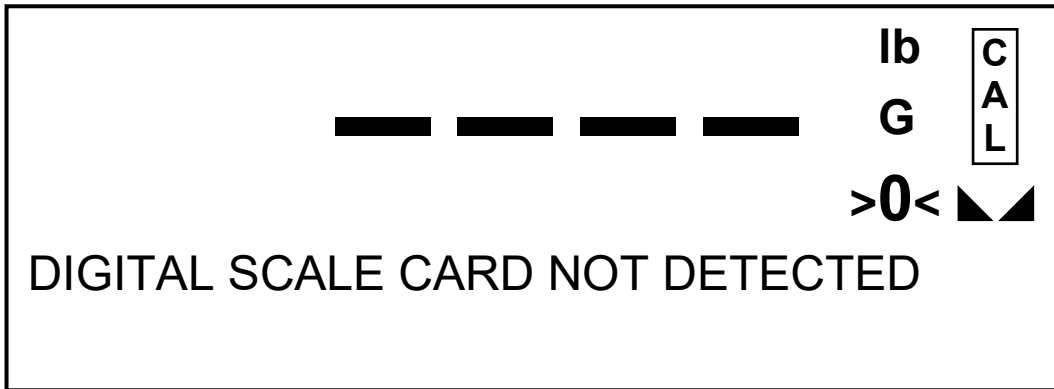

Probable Cause	Items to Check
The 225D cannot communicate with the DLC controller card, or the DLC controller card is not responding.	<ul style="list-style-type: none"> • Check that the card is seated properly and fastened correctly. • Check that the card is seated on the correct row of pins. • Potential of a failed card if it occurs after installation and in-service.

DIGITAL SCALE DIAGNOSTICS, CONT.

Cell Diagnostics

Note that all diagnostic information except software version updates once per second.

With the indicator ON, press the **SHIFT** key and then press the Navigation **ENTER** key (red square key in the center of the Navigation arrows). The display will change to show the SETUP/REVIEW MENU.

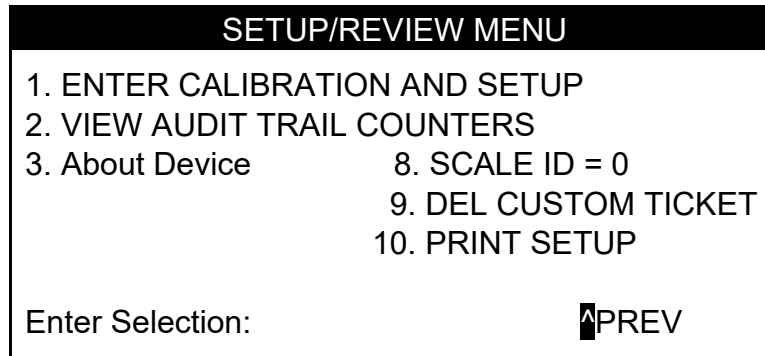

1. With the SETUP/REVIEW MENU displayed, press the **1** key and then the **ENTER** key. The display will change to show SETUP MENU #1.
2. Press **NEXT** (Navigation Keys ▾ Down Arrow) to proceed to the SETUP MENU #2.
3. Press **NEXT** (Navigation Keys ▾ Down Arrow) to proceed to the SETUP MENU #3.
4. Press **NEXT** (Navigation Keys ▾ Down Arrow) to proceed to the SETUP MENU #4.

1. Cell Diagnostics

With SETUP MENU #4 displayed, press the **1** key and then the **ENTER** key to proceed with the Cell Diagnostics. The display will change to show Load Cell Weight.

Load Cell Weight (Live Weights)

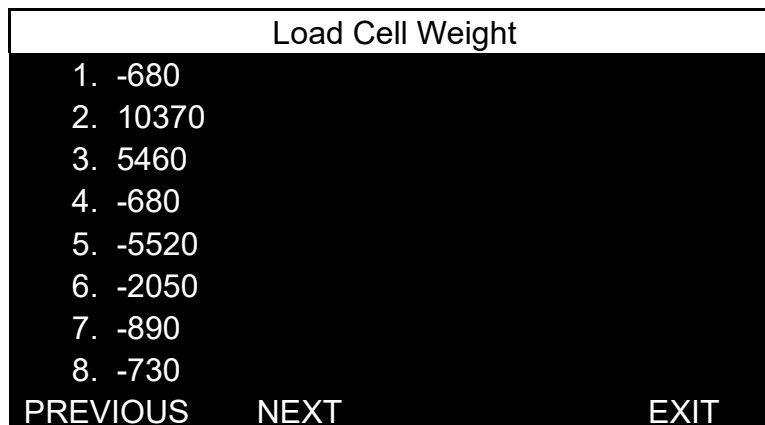

- Press the **Zero** key to reset the Live Load Cell Weights to zero. Note that this does not affect the scale zero.
- Press the **NEXT** soft key to advance to the **Max / Min Cell Weight** diagnostic screen.

DIGITAL SCALE DIAGNOSTICS, CONT.

Cell Diagnostics, Cont.

Max / Min Cell Weight (Maximum and Minimum Load Cell Weight)

Max / Min Cell Weight		
1. -680 /	-680	
2. 10370 /	10370	
3. 5460 /	5460	
4. -680 /	-680	
5. -5520 /	-5520	
6. -2050 /	-2050	
7. -890 /	-890	
8. -730 /	-730	
PREVIOUS	NEXT	EXIT

- Press the **Zero** selection to reset the Maximum / Minimum Weights to zero.
- Press the **NEXT** soft key to advance to the **Deadload Shift** diagnostic screen.
- Press the **PREVIOUS** soft key to return to the **Load Cell Weight** diagnostics screen.



IMPORTANT! Zeroing the **Load Cell Weight** and **Max / Min Cell Weight** screens is only temporary while in diagnostics. It does not affect the scale weight working zero. If you exit diagnostics and return, the weights will have returned to the previous values.

Dead Load Shift

This diagnostics screen shows the live shift from the original calibrated deadload. An asterisk (*) indicates that the deadload shift has been exceeded (over 25%). The scale must be **empty** for this to be valid.

Dead Load Shift		
1. -680		
2. 10370		
3. 5460		
4. -680		
5. -5520		
6. -2050		
7. -890		
8. -730		
PREVIOUS	NEXT	EXIT

- Press the **NEXT** soft key to advance to the **Cell Software Version** diagnostic screen.
- Press the **PREVIOUS** soft key to return to the **Max / Min Cell Weight** diagnostics screen.

DIGITAL SCALE DIAGNOSTICS, CONT.

Cell Diagnostics, Cont.

Cell Software Version

Cell Software Version		
1.	1.0.14	
2.	1.0.16	
3.	1.0.16	
4.	1.0.14	
5.	1.0.16	
6.	1.0.16	
7.	1.0.14	
8.	1.0.14	
PREVIOUS	NEXT	EXIT

- Press the **NEXT** soft key to advance to the **Cell Error Count** diagnostic screen.
- Press the **PREVIOUS** soft key to return to the **Dead Load Shift** diagnostics screen.

NOTE: The DLC controller's version number, in contrast, is displayed upon startup of the 225D indicator.

Cell Error Count

Cell Error Count		
1.	1	
2.	1	
3.	0	
4.	1	
5.	1	
6.	0	
7.	0	
8.	0	
PREVIOUS	NEXT	EXIT

- Press the **NEXT** soft key to advance to the **DLC Card Error Communication** diagnostic screen.
- Press the **PREVIOUS** soft key to return to the **Cell Software Version** diagnostics screen.

DIGITAL SCALE DIAGNOSTICS, CONT.

Cell Diagnostics, Cont.

DLC Card Error Communication

DLC Card Error Communication	
1. Overflow	0
2. Bus Off	0
3. CAN Err	0
4. SPI CRC Err	0
PREVIOUS	NEXT
	EXIT

Overflow	This is the count of any missed messages from the DLC card buffer that were not kept up with. This should not happen unless too many cells are connected with too high a sample rate.
Bus Off	This does not happen if you completely disconnect the home run cable, but it does count up if V+ or V- is disconnected.
CAN Err	This counts for any of the following errors: <ul style="list-style-type: none"> • Weight Error Count • Cell Power Supply Voltage
SPI CRC Err	This is a count of communication errors from the 225D mainboard to the DLC card.

Weight Error Count

Weight Error Count	
1. 0	
2. 0	
3. 0	
4. 0	
5. 0	
6. 0	
7. 0	
8. 0	
PREVIOUS	NEXT
	EXIT

- Press the **NEXT** soft key to advance to the **Cell Power Supply Voltage** diagnostic screen.
- Press the **PREVIOUS** soft key to return to the **DLC Card Error Communication** diagnostics screen.

DIGITAL SCALE DIAGNOSTICS, CONT.

Cell Diagnostics, Cont.

Cell Power Supply Voltages

Cell Power Supply Voltage	
1. 14.17	8. 14.14
2. 14.31	
3. 14.21	
4. 14.14	
5. 14.21★	
6. 14.16	
7. 14.13	
0.457 Amps	
PREVIOUS	NEXT
	EXIT

NOTES:

- The ★ on cell number 5, indicates the cell voltage measurement was not calibrated, but is an approximate value based on the raw counts.
- The 0.457 Amps in this example shows the approximate current draw from the DLC for all of the cells. Unless an external power is being used, the more cells that are connected, the larger this number will be.
- Press the **NEXT** soft key to advance to the **ISITE STATUS OF LAST CONN** (iSite Status of Last Connection) diagnostic screen.
- Press the **PREVIOUS** soft key to return to the **Weight Error Count** diagnostics screen.

DIGITAL SCALE DIAGNOSTICS, CONT.

Cell Diagnostics, Cont.

ISITE STATUS OF LAST CONN (iSite Status of Last Connection)

ISITE STATUS OF LAST CONN	
1. IP	192.168.1.70
2. Ethernet Detect:	CONNECTED
3. Binding	COMM OK
4. HTTP RESP	0

PREVIOUS NEXT EXIT

The following information is shown:

1. IP IP address
 2. Ethernet Detect: Ethernet cable state – CONNECTED – OR – NOT CONNECTED
 3. Binding The status of the connection. The following statuses should occur in order while making a connection after bootup:
 - a. SOCKET ERROR
 - b. IP NOT BOUND
 - c. DNS RESOLVING SERVER IP
 - d. COMM OK – OR – COMM FAIL
 4. HTTP RESP Once there is a connection to the web server, the previous HTTP response will be displayed.
 - a. A good response is HTTP RESP 0.
 - b. Any other response means there is a problem.
Note that many issues are caused by the SO# not being entered in the indicator, such as:
HTTP RESP 404 Check SO
- Press the **NEXT** soft key to advance to the **Cell Temperature** diagnostic screen.
 - Press the **PREVIOUS** soft key to return to the **Cell Power Supply Voltage** diagnostics screen.

DIGITAL SCALE DIAGNOSTICS, CONT.

Cell Diagnostics, Cont.

Cell Temperature

This is the temperature of the load cells in Celsius.

Cell Temperature		
1.	-40	
2.	-40	
3.	-40	
4.	-40	
5.	-40	
6.	-40	
7.	-40	
8.	-40	
PREVIOUS	NEXT	EXIT

- Press the **PREVIOUS** soft key to advance to the **ISITE STATUS OF LAST CONN** (iSite Status of Last Connection) diagnostic screen.
- Press the **NEXT** soft key to return to the **Load Cell Weight** diagnostics screen, where you can repeat and review the diagnostics screens as needed.
- Press the **EXIT** soft key to return to the SETUP MENU #4.

With SETUP MENU #4 displayed, press **PREV** (Navigation Keys Δ UP Arrow) until the display has returned to the normal weighing display.

DIGITAL SCALE DIAGNOSTICS, CONT.

Hardware Diagnostics

The 195/225-DLC (Digital Load Cell Controller) card has four LEDs for diagnostic purposes.

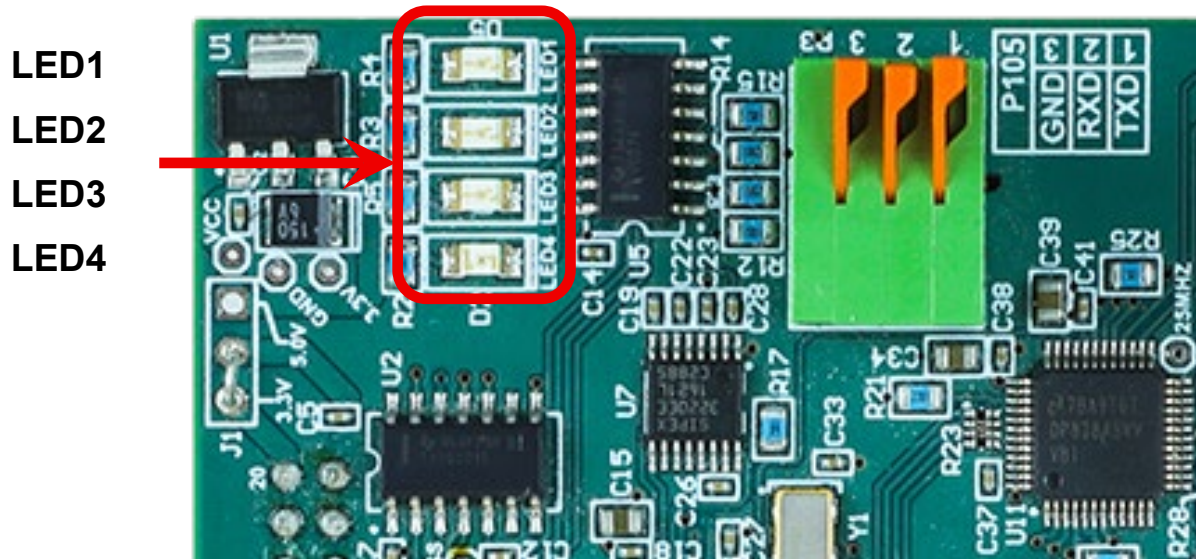

Figure No. 17

LED	FUNCTION	DESCRIPTION
LED1 (RED)	MAIN BOARD TX/RX:	Toggles each time the DLC controller and the 225D Mainboard exchange messages.
LED2 (RED)	TX TO LOAD CELL:	Toggles each time a message is sent from the DLC controller to the load cells.
LED3 (RED)	RX FROM LOAD CELL:	Toggles each time the DLC controller receives a response from some or all the load cells. Blinking does not mean that it got a response from EVERY load cell. If a load cell does not respond, the 225D will drop into INIT MODE.
LED4 (GREEN)	MODE:	Indicates the mode of the DLC controller
	INIT MODE	Blinks once per second. If the 225D drops into INIT MODE, it is because setup is required, or it cannot find all the load cells.
	NORMAL MODE	Solid ON.
	DIAGNOSTIC MODE	Blinks twice per second. This should happen when the operator enters the diagnostics menus.

DLC CONTROLLER CARD REPLACEMENT



CAUTION! OBSERVE THE PRECAUTIONS FOR HANDLING STATIC SENSITIVE DEVICES

1. Remove the 225D power cord from the wall outlet or turn off the breaker for the indicator.
2. Open the indicator enclosure to access the 195/225-DLC controller card. The procedure varies by indicator model. Refer to the instructions below for your specific model.

225D-D Desktop Indicator:

Referring to Figure No. 4, remove the 2 thumbscrews securing the front panel to the rear enclosure, and then lower the front panel. **NOTE:** You may need to loosen the gland connectors to allow enough slack in the cable and wires to avoid stretching them.

225D-S Stainless Steel Indicator:

Referring to Figure No. 5, remove the 8 acorn nuts securing the rear panel to the front enclosure. Lift the rear panel from the front enclosure, taking care not to stretch the cable and wires between the rear panel and front enclosure. Lay the rear panel on the workbench/table next to the indicator. **NOTE:** You may need to loosen the gland connectors to allow enough slack in the cable and wires to avoid stretching them.

3. Disconnect the Homerun cable wires from the 195/225DLC controller card and remove the Ethernet cable if one is connected to the Ethernet port.
4. Remove the screw and washer securing the 195/225DLC controller card to the 225D mainboard.
5. Gently rock the 195/225DLC controller card from side to side while pulling up to remove it from the connector on the mainboard.
6. To install the new 195/225DLC controller card, carefully align the dual row of pins on the bottom of the new controller card (the trace side of the card) with the Scale/DLC Card connector P14 on the mainboard and apply even downward pressure to the edge of the 195/225DLC controller card.
7. Align the hole in the 195/225DLC controller card with the threaded mounting spacer on the mainboard.
8. Secure the 195/225DLC controller card to the mainboard, using the screw and washer removed earlier.

DLC CONTROLLER CARD REPLACEMENT, CONT.

9. Referring to the table below (or on the circuit board) for terminal connections, reconnect each of the wires from the Homerun cable to the P5 terminal block on the 195/225-DLC controller card.

Homerun Cable Connection to P5 Terminal Block

Board Label	Homerun Cable Wire Color	Wire Color if using a Load Cell Cable
V-BUS	BLACK	BLUE
CAN L	BLUE or LIGHT BLUE	GRAY
SHIELD	GRAY	BROWN
CAN H	WHITE	BLACK
V+BUS	RED	WHITE

10. Referring to Figure No. 18 below, use a small flat-blade screwdriver to press down on the release for the terminal, insert the wire into the opening, and then remove the screwdriver. The release will return to its original position, locking the wire in place.

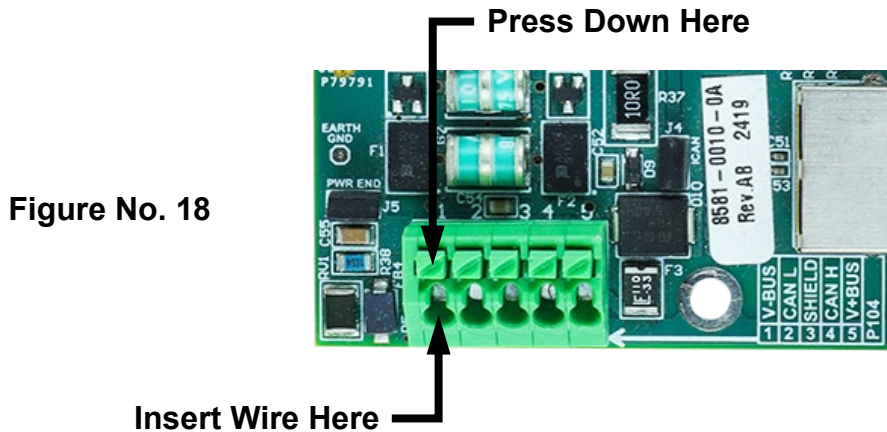

14. Repeat steps 9 and 10 until all five wires of the homerun cable are installed in the P5 terminal block on the 195/225-DLC controller card.
15. After completing all terminations, remove any excess homerun cable from the indicator enclosure. Then, securely tighten any cable gland connectors that were previously loosened. Do not overtighten the gland connectors, but ensure they are snug.
16. Completing the DLC controller card replacement is dependent on the indicator model:

225D-D Desktop Indicator:

Close the front panel by lifting it until it is against the main enclosure, and then secure the front panel to the main enclosure with the 2 thumbscrews removed earlier.

225D-S Stainless Steel Indicator:

Replace the rear panel and secure it to the front enclosure with the 8 acorn nuts removed earlier. Securely tighten the acorn nuts with a 3/8 in wrench or ratchet and 3/8 in socket. Follow a diagonal pattern when tightening the acorn nuts.

17. Proceed to the **DETECTING BOARD REPLACEMENTS** section to complete the DLC controller card replacement.

DETECTING BOARD REPLACEMENTS

The 225D detects when the DLC controller card or the mainboard has been replaced by using checksums and unique board identification numbers. Based on multiple parameters, the 225D determines which component was replaced and automatically reconfigures the new hardware to the existing scale.

Detecting Mainboard or DLC Controller Card Replacement

When either the mainboard or the DLC controller card has been replaced, the 225D boots and first prompts the operator to confirm whether the mainboard has been replaced.



Mainboard Replaced

If the operator selects **YES** to indicate that the mainboard has been replaced, the scale configuration stored in the DLC controller card will be downloaded to the new mainboard.

- The scale configuration includes the number of load cells, all load cell IDs, and individual load cell trim values.
- The 225D indicator parameters must be entered manually, including Interval, Decimal Point Position, Zero Tracking, Filtering, Print Settings, and Serial Settings.



IMPORTANT! A dead load calibration will need to be performed (does not require test weights).

Mainboard NOT Replaced

If the operator selects **NO** to indicate the Mainboard has NOT been replaced, the 225D display will change to prompt the operator to confirm whether the DLC controller card has been replaced.

DETECTING BOARD REPLACEMENTS

After the operator selects **NO** at the prompt confirming whether the mainboard has been replaced, the 225D display will change to prompt the operator to confirm whether the DLC controller card has been replaced.



DLC Controller Card Replaced

If the operator selects **YES** to indicate that the DLC controller card has been replaced, the scale configuration stored in the mainboard will be downloaded to the new DLC controller.

Once this process is complete, the 225D will immediately be able to make weight and resume normal weighing operations.

DLC Controller Card NOT Replaced

If the operator selects **NO** to indicate that the DLC controller card has NOT been replaced, the 225D will return to the normal weighing display and be able to resume weighing operations.

ISITE CONFIGURATION

The 225D will periodically send indicator, scale, and cell data to the Cardinal iSite Webserver for diagnostic logging. The server will use this information to determine if there are problems with the scale(s) that need to be addressed.

ISITE IP CONFIG Menu

With the indicator ON, press and hold the **SHIFT** key and then press the **ENTER** key or the Navigation **ENTER** key (red square key in the center of the Navigation arrows). The display will change to show the SETUP/REVIEW MENU.

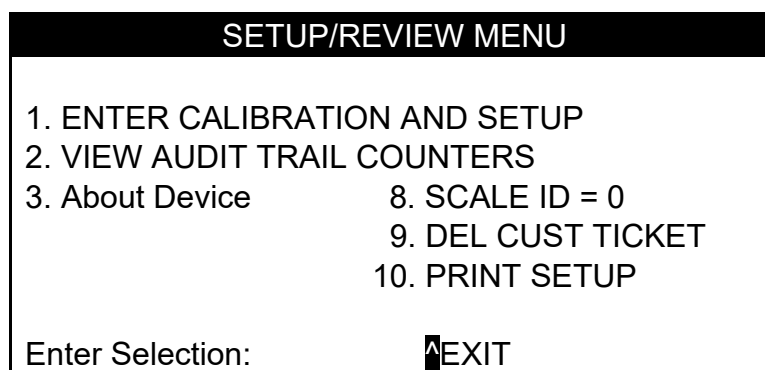

With the SETUP/REVIEW MENU displayed, press the **1** key and then the **ENTER** key. The display will change to show SETUP MENU #1.

Press **NEXT** (Navigation Keys ▾ Down Arrow) to proceed to the SETUP MENU #2.

Press **NEXT** (Navigation Keys ▾ Down Arrow) to proceed to the SETUP MENU #3.

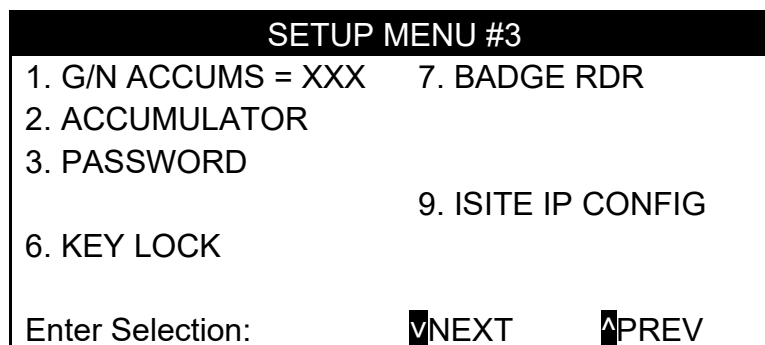

ISITE CONFIGURATION, CONT.

ISITE IP CONFIG Menu

With the SETUP MENU #3 displayed, press the **9** key and then the **ENTER** key. The display will change to show the ISITE IP CONFIG menu.

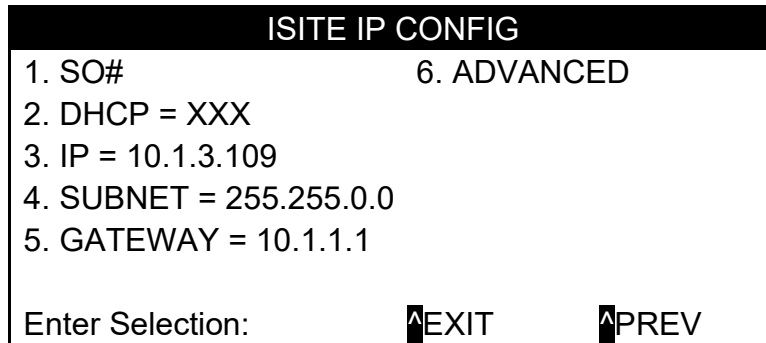

1. SO# = XXXXXX (Sales Order Number)

The SO# of the scale is used to match the scale to the correct iSite dealer account.

With the ISITE IP CONFIG menu displayed, press the **1** key and then the **ENTER** key. The display will change to prompt for the SO# (Sales Order Number).

Using the alphanumeric keys, enter the value for SO#, and then press the **ENTER** key to save the new setting and return to the ISITE IP CONFIG menu.

2. DHCP = XXX (Enable or Disable DHCP)

With the ISITE IP CONFIG menu displayed, the current setting for the DHCP parameter will be shown. Note that XXX is the current value. If the setting displayed is acceptable, proceed to the next setup parameter.

Otherwise, press the **2** key, the **ENTER** key, and then using the numeric keys, enter the value for DHCP, and then press the **ENTER** key to save the new setting and return to the ISITE IP CONFIG menu.

Allowable values are 1 = Yes or 2 = No.

Select **Yes** for automatic configuration of the DLC card Ethernet parameters from a DHCP server.

DHCP = Yes

Select **Yes** for automatic configuration of the DLC card Ethernet parameters from a DHCP server.

DHCP = No

If a static IP address is required (such as to address firewall issues), then set to **No**. Note that a static IP address is assigned by your network administrator and manually entered.

ISITE CONFIGURATION, CONT.

ISITE IP CONFIG Menu, Cont.



IMPORTANT! When **No** is selected for **DHCP** on the ISITE IP CONFIG screen, additional parameters will become accessible. Note that these parameters are also visible when Yes is selected, but they cannot be modified.

3. IP (IP Address)

With Enable DHCP set to No, the current setting for the IP Address will be shown. If the setting displayed is acceptable, press **PREV** (Navigation Keys Δ UP Arrow) to return to the ISITE IP CONFIG menu.

Otherwise, press the **3** key, the **ENTER** key, and then using the numeric keys, enter the values for the four octets of the Static IP address, and press **PREV** (Navigation Keys Δ UP Arrow) to save the new setting and return to the ISITE IP CONFIG menu.

Static IP	
1. Static IP 1 = XXX	
2. Static IP 2 = XXX	
3. Static IP 3 = XXX	
4. Static IP 4 = XXX	
Enter Selection:	EXIT PREV

4. SUBNET (Subnet Mask)

With Enable DHCP set to No, the current setting for the Subnet Mask will be shown. If the setting displayed is acceptable, press **PREV** (Navigation Keys Δ UP Arrow) to return to the ISITE IP CONFIG menu.

Otherwise, press the **4** key, the **ENTER** key, and then using the numeric keys, enter the values for the four octets of the network Subnet Mask, and press **PREV** (Navigation Keys Δ UP Arrow) to save the new setting and return to the ISITE IP CONFIG menu.

Static IP	
1. Subnet 1 = XXX	
2. Subnet 2 = XXX	
3. Subnet 3 = XXX	
4. Subnet 4 = XXX	
Enter Selection:	EXIT PREV

ISITE CONFIGURATION, CONT.

ISITE IP CONFIG Menu, Cont.

5. GATEWAY

With Enable DHCP set to No, the current setting for the Gateway will be shown. If the setting displayed is acceptable, press **PREV** (Navigation Keys Δ UP Arrow) to return to the ISITE IP CONFIG menu.

Otherwise, press the **5** key, the **ENTER** key, and then using the numeric keys, enter the values for the four octets of the network Gateway IP address, and press **PREV** (Navigation Keys Δ UP Arrow) to save the new setting and return to the ISITE IP CONFIG menu.

Gateway	
1. Gateway 1 = XXX	
2. Gateway 2 = XXX	
3. Gateway 3 = XXX	
4. Gateway 4 = XXX	
Enter Selection:	EXIT PREV

ISITE ADVANCED CONFIG Menu

6. ADVANCED

With the ISITE IP CONFIG menu displayed, press the **6** key and then the **ENTER** key to proceed to the ISITE ADVANCED CONFIG menu.

ISITE ADVANCED CONFIG	
1. MANUAL DNS = XXX	
2. IP = X.X.X.X	
3. IP = X.X.X.X	
4. PING TEST	
Enter Selection:	EXIT PREV

ISITE CONFIGURATION, CONT.

ISITE ADVANCED CONFIG Menu, Cont.

MANUAL DNS

Manual DNS refers to the practice of explicitly configuring the DNS (Domain Name System) server addresses on a device or network, rather than allowing them to be assigned automatically by the network's DHCP server.

By default, **MANUAL DNS** is set to **Yes** on the 225D. Automatic DNS assignment is disabled, and one or more DNS server IP addresses must be entered manually.

Common DNS examples:

- Google DNS: 8.8.8.8 and 8.8.4.4
- Cloudflare DNS: 1.1.1.1 and 1.0.0.1
- OpenDNS: 208.67.222.222 and 208.67.220.220

When **MANUAL DNS** is set to **No** on the 225D, automatic DNS assignment is enabled. The network DHCP server automatically assigns the DNS Server IP addresses, so no user input is required.

1. **MANUAL DNS = XXX (Disable or Enable MANUAL DNS)**

With the ISITE ADVANCE CONFIG menu displayed, the current setting for the MANUAL DNS parameter will be shown. Note that XXX is the current value. If the setting displayed is acceptable, proceed to the next setup parameter.

Otherwise, press the **1** key, the **ENTER** key, and then using the numeric keys, enter the value for MANUAL DNS, and then press the **ENTER** key to save the new setting and return to the ISITE ADVANCE CONFIG menu.

Allowable values are 1 = Yes or 2 = No.

Select **Yes** for automatic configuration of the DLC card Ethernet parameters from a DHCP server.

MANUAL DNS = Yes

Select **Yes** if the local network does not provide DNS via a DHCP server. Note that the DNS Server IP address is assigned by your network administrator and manually entered.

MANUAL DNS = No

Select **No** for automatic assignment of the DNS Server IP address from a DHCP server.

ISITE CONFIGURATION, CONT.

ISITE ADVANCED CONFIG Menu, Cont.



IMPORTANT! When **Yes** is selected for **MANUAL DNS** on the ISITE ADVANCED CONFIG screen, additional parameters will become accessible. Note that these parameters are also visible when **No** is selected, but they cannot be modified.

2. IP (DNS1 IP Address)

With MANUAL DNS set to Yes, the current setting for the DNS1 IP Address will be shown. If the setting displayed is acceptable, press **PREV** (Navigation Keys Δ UP Arrow) to return to the ISITE ADVANCED CONFIG menu.

Otherwise, press the **2** key, the **ENTER** key, and then using the numeric keys, enter the values for the four octets of the Static IP address, and press **PREV** (Navigation Keys Δ UP Arrow) to save the new setting and return to the ISITE ADVANCED CONFIG menu.

DNS1	
1. DNS Value1 = X	
2. DNS Value2 = X	
3. DNS Value3 = X	
4. DNS Value4 = X	
Enter Selection:	EXIT PREV

3. IP (DNS2 IP Address)

With MANUAL DNS set to Yes, the current setting for the DNS2 IP Address will be shown. If the setting displayed is acceptable, press **PREV** (Navigation Keys Δ UP Arrow) to return to the ISITE ADVANCED CONFIG menu.

Otherwise, press the **3** key, the **ENTER** key, and then using the numeric keys, enter the values for the four octets of the Static IP address, and press **PREV** (Navigation Keys Δ UP Arrow) to save the new setting and return to the ISITE ADVANCED CONFIG menu.

DNS2	
1. DNS Value1 = X	
2. DNS Value2 = X	
3. DNS Value3 = X	
4. DNS Value4 = X	
Enter Selection:	EXIT PREV

ISITE CONFIGURATION, CONT.

ISITE ADVANCED CONFIG Menu, Cont.

4. PING TEST

With the ISITE ADVANCED CONFIG menu displayed, press the **4** key and then the **ENTER** key to proceed to the PING TEST screen.

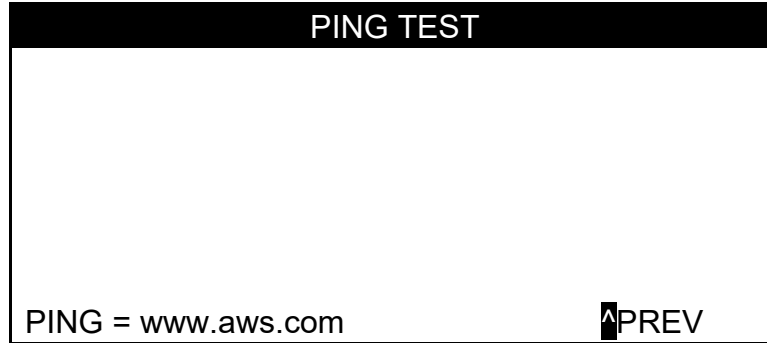

With the PING TEST screen displayed, the URL (www.aws.com) for the ping test will be shown. Press the **ENTER** key to begin the ping test.

Over several seconds, the ping test will occur and display the results of the resolved IP address, along with the response time in milliseconds.

PING TEST		
108.157.150.49	22	ms
108.157.150.49	22	ms
108.157.150.49	22	ms
108.157.150.49	21	ms
108.157.150.49	21	ms
0.0.0.0	253	ms
0.0.0.0	253	ms
0.0.0.0	253	ms
0.0.0.0		EXIT

When completed, the 225D will “beep” and display the **EXIT** soft key.

Press the **EXIT** soft key to return to the PING TEST screen.

Press **PREV** (Navigation Keys Δ UP Arrow) to return to the ISITE ADVANCED CONFIG menu.

Press **PREV** (Navigation Keys Δ UP Arrow) to return to the ISITE IP CONFIG menu.

Press **PREV** (Navigation Keys Δ UP Arrow) until the display has returned to the normal weighing display.

STATEMENT OF LIMITED WARRANTY

WARRANTY TERMS

Cardinal Scale Manufacturing Company warrants the equipment we manufacture against defects in material and workmanship. The length and terms and conditions of these warranties vary with the type of product and are summarized below:

PRODUCT TYPE	TERM	MATERIAL AND WORKMANSHIP	LIGHTNING DAMAGE See note 9	WATER DAMAGE See note 7	CORROSION See note 4	ON-SITE LABOR	LIMITATIONS AND REQUIREMENTS
WEIGHT INDICATORS	90 DAY REPLACEMENT ----- 1 YEAR PARTS	YES	YES	YES	YES	NO	1, 2, 3, 5, 6 A, B, C, D
LOAD CELLS (Excluding Hydraulic)	1 YEAR	YES	YES	YES	YES	NO	1, 2, 3, 5, 6 A, B, C, D
HYDRAULIC LOAD CELLS (When purchased with Guardian Vehicle Scale)	LIFETIME	YES	YES	YES	YES	90 DAYS	1, 5, 6, 8 A, B, C, D
HYDRAULIC LOAD CELLS (When purchased separately)	10 YEARS	YES	YES	YES	YES	NO	1, 5, 6, 8, 9 A, B, C, D
VEHICLE SCALE (Deck and Below Excl. PSC Series)	5 YEARS	YES	YES	YES	YES	90 DAYS	1, 2, 3, 5, 6 A, B, C, D, E
LSC SCALE (Deck and Below)	3 YEARS	YES	YES	YES	YES	90 DAYS	1, 2, 3, 5, 6, 11 A, B, C, D
GUARDIAN FLOOR SCALES	10 YEARS	YES	YES	YES	YES	NO	1, 2, 3, 5, 6, 9, 10 A, B, C, D
ALL OTHER CARDINAL PRODUCTS	1 YEAR	YES	YES	YES	YES	NO	1, 2, 5, 6 A, B, C, D, E
REPLACEMENT PARTS	90 DAYS	YES	YES	YES	YES	NO	1, 2, 4, 5, 6 A, B, C, D
SWIM AND 760 SERIES VEHICLE SCALES	1 YEAR	YES	YES	YES	YES	90 DAYS	1, 2, 5, 6 A, B, C, D
SOFTWARE	90 DAYS	YES	N/A	N/A	N/A	NO	1, 6 B, C, D
CONVEYOR BELT SCALES (including Belt-Way)	1 YEAR	YES	YES	YES	YES	NO	1, 2, 3, 5, 6 A, B, C, D, E, F



CARDINAL

Ph. (800) 441-4237
E-mail: cardinal@cardet.com
102 E. Daugherty
Webb City, MO 64870

04/24
Printed in USA
315-WARRANTY-CAR-M

APPLICABLE LIMITATIONS AND REQUIREMENTS

1. This warranty applies only to the original purchaser. The warranty does not apply to equipment that has been tampered with, defaced, damaged, or had repairs or modifications not authorized by Cardinal or has had the serial number altered, defaced or removed.
2. This warranty is not applicable to equipment that has not been grounded in accordance with Cardinal's recommendations.
3. This equipment must be installed and continuously maintained by an authorized Cardinal / Belt-Way dealer.
4. Applies only to components constructed from stainless steel.
5. This warranty does not apply to equipment damaged in transit. Claims for such damage must be made with the responsible freight carrier in accordance with freight carrier regulations.
6. Warranty term begins with date of shipment from Cardinal.
7. Only if device is rated NEMA 4 or better or IP equivalent.
8. Lifetime warranty applies to damages resulting from water, lightning, and voltage transients and applies only to the hydraulic load cell structure itself (does not include pressure transducers, rubber seals, o-rings, and associated wiring).
9. 10-Year prorated warranty on hydraulic load cells.
10. 1-Year warranty for scale structure.
11. PSC models' warranty coverage applies only to agricultural installations on farms up to 3,000 acres (LSC models not limited in this manner).
12. Load cell kits MUST be installed in accordance with Cardinal Scale instructions. Failure to follow these instructions will void the warranty.

EXCLUSIONS

- A.) This warranty does not include replacement of consumable or expendable parts. The warranty does not apply to any item that has been damaged due to unusual wear, abuse, improper line voltage, overloading, theft, fire, water, prolonged storage or exposure while in purchaser's possession or acts of God unless otherwise stated herein.
- B.) This warranty does not apply to peripheral equipment not manufactured by Cardinal. This equipment will normally be covered by the equipment manufacturer's warranty.
- C.) This warranty sets forth the extent of our liability for breach of any warranty or deficiency in connection with the sale or use of our product. Cardinal will not be liable for consequential damages of any nature, including but not limited to loss of profit, delays or expenses, whether based on tort or contract. Cardinal reserves the right to incorporate improvements in material and design without notice and is not obligated to incorporate said improvements in equipment previously manufactured.
- D.) This warranty is in lieu of all other warranties expressed or implied including any warranty that extends beyond the description of the product including any warranty of merchantability or fitness for a particular purpose. This warranty covers only those Cardinal products installed in the forty-eight contiguous United States and Canada.
- E.) This warranty does not cover paint coatings due to the variety of environmental conditions.
- F.) Do not cut load cell cables on load cells returned for credit or warranty replacement. Cutting the cable will void the warranty.
- G.) Software is warranted only for performance of the functions listed in the software manual and/or the Cardinal proposal.
- H.) The software warranty does not cover hardware. Warranties on hardware are provided from the hardware vendor only.
- I.) The software warranty does not cover interfacing issues to non-Cardinal supplied hardware.
- J.) The software warranty does not include automatic software upgrades unless purchased separately.



Ph. (800) 441-4237
E-mail: cardinal@cardet.com
102 E. Daugherty
Webb City, MO 64870

04/24
Printed in USA
315-WARRANTY-CAR-M

Cardinal Scale Mfg. Co.

102 E. Daugherty, Webb City, MO 64870 USA

Ph: 417-673-4631 or 1-800-641-2008

Fax: 417-673-2153

www.cardinalscale.com

Technical Support: 1-866-254-8261

E-mail: tech@cardet.com

Printed in USA

8200-0890-0M Rev A 12/25