



CARDINAL®



212G/212GX WEIGHT INDICATOR Installation and Technical Manual

INTRODUCTION

Thank you for selecting and purchasing the Cardinal Model 212G/212GX Weight Indicator. The Model 212G/212GX was built with quality and reliability at our factory in Webb City, Missouri and incorporates the latest in digital technology and innovative features for the weighing industry. Configuration and upgrades can easily be performed in the field, while still maintaining the rigid control the most demanding installations require. This flexibility insures the Model 212G/212GX will be able to meet your weight indicating needs for years to come.

The purpose of this manual is to provide you with a guide through installation, setup and operation of your new Model 212G/212GX Weight Indicator. Please read it thoroughly before attempting to install your weight transmitter and keep it handy for future reference.

COPYRIGHT

All rights reserved. Reproduction or use, without expressed written permission, of editorial or pictorial content, in any manner, is prohibited. No patent liability is assumed with respect to the use of the information contained herein.

DISCLAIMER

While every precaution has been taken in the preparation of this manual, the Seller assumes no responsibility for errors or omissions. Neither is any liability assumed for damages resulting from use of the information contained herein. All instructions and diagrams have been checked for accuracy and ease of application; however, success and safety in working with tools depend to a great extent upon the individual accuracy, skill and caution. For this reason the Seller is not able to guarantee the result of any procedure contained herein. Nor can they assume responsibility for any damage to property or injury to persons occasioned from the procedures. Persons engaging the procedures do so entirely at their own risk.

SERIAL NUMBER _____
DATE OF PURCHASE _____
PURCHASED FROM _____

RETAIN THIS INFORMATION FOR FUTURE USE

PRECAUTIONS

Before using this indicator, read this manual and pay special attention to all "NOTIFICATION" symbols:



IMPORTANT



ELECTRICAL
WARNING



STATIC
SENSITIVE

FCC COMPLIANCE STATEMENT

This equipment generates uses and can radiate radio frequency and if not installed and used in accordance with the instruction manual, may cause interference to radio communications. It has been tested and found to comply with the limits for a Class A computing device pursuant to Subpart J of Part 15 of FCC rules, which are designed to provide reasonable protection against such interference when operated in a commercial environment. Operation of this equipment in a residential area may cause interference in which case the user will be responsible to take whatever measures necessary to correct the interference.

You may find the booklet "How to Identify and Resolve Radio TV Interference Problems" prepared by the Federal Communications Commission helpful. It is available from the U.S. Government Printing Office, Washington, D.C. 20402, stock No. 001-000-00315-4.

PROPER DISPOSAL

When this device reaches the end of its useful life, it must be properly disposed of. It must not be disposed of as unsorted municipal waste. Within the European Union, this device should be returned to the distributor from where it was purchased for proper disposal. This is in accordance with EU Directive 2002/96/EC. Within North America, the device should be disposed of in accordance with the local laws regarding the disposal of waste electrical and electronic equipment.

It is everyone's responsibility to help maintain the environment and to reduce the effects of hazardous substances contained in electrical and electronic equipment on human health. Please do your part by making certain that this device is properly disposed of. The symbol shown to the right indicates that this device must not be disposed of in unsorted municipal waste programs.



CAUTION



CAUTION: RISK OF EXPLOSION IF BATTERY IS REPLACED BY AN INCORRECT TYPE. DISPOSE OF USED BATTERIES ACCORDING TO THE INSTRUCTIONS.

ATTENTION: RISQUE D'EXPLOSION SI LA BATTERIES EST REMPLAC'E PAR UN TYPE INCORRECT. REJETEZ LES BATTERIES UTILISE'ES SELON LES INSTRUCTIONS.

TABLE OF CONTENTS

SPECIFICATIONS	Page 1
Standard Features	Page 2
Optional Features	Page 2
PRECAUTIONS	Page 4
SITE PREPARATION REQUIREMENTS	Page 5
INSTALLATION	Page 7
Mounting	Page 7
Load Cell Connection	Page 8
Serial I/O Cable Installation	Page 10
USB Interface and USB Cable Installation	Page 12
Main PC Board I/O Functions Table	Page 13
RB4/RB8 Relay Box Cable Wire Number To Relay Number Table	Page 13
Optically Isolated Remote Inputs	Page 14
AC Input Relay Board(S)	Page 14
PWC/Checkweigher Logic Level Output	Page 16
AC Output Relay Board(S)	Page 17
RB4C Relay J-Box	Page 18
Main PCB (Figure No. 15)	Page 19
Main PCB Jumpers	Page 20
Re-Installing The Front Panel	Page 20
KEYPAD FUNCTIONS	Page 21
ANNUNCIATORS	Page 29
SETUP AND CALIBRATION	Page 33
Setup	Page 34
Analog to Digital Filtering	Page 38
Calibration	Page 41
Setup Guardian Scale	Page 45
Mode of Operation	Page 45
Serial Input/Output	Page 52
Print Tab Settings	Page 61
Fine Span Adjustment	Page 63
Display High Resolution Weight	Page 63
Key Lock Out Function	Page 63
Option Card Configuration	Page 63
SETUP REVIEW	Page 65
CALIBRATION "C" NUMBERS	Page 67
DISPLAY BACKLIGHT THRESHOLD	Page 69
ACCUMULATORS	Page 71
ERROR CODES	Page 73
BEFORE YOU CALL SERVICE	Page 77
CALIBRATION SEAL INSTALLATION	Page 79
ID STORAGE OPERATION	Page 81
DIGITAL FILL CONTROL MODE OPERATION	Page 89
DIGITAL FILL CONTROL ID STORAGE	Page 97
AXLE WEIGHER OPERATION MODE	Page 101
LIVESTOCK WEIGHER MODE OPERATION	Page 103
LOCAL/REMOTE SETUP	Page 104
PARTS IDENTIFICATION	Page 106

SPECIFICATIONS

Power Requirements:	100 to 240 VAC (50/60 Hz) at 0.4A Max.
Enclosure Type:	Thermoplastic
Enclosure Size:	9.0" H x 11.2" W x 4.3" D (229mm H x 284mm W x 109mm D)
Shipping Weight:	12 lbs / 5.4 kg
Operating Environment:	Compensated Temperature Range: 14° to 104° F (-10° to +40° C) Operated Temperature Range: -10° to 122° F (-23° to +50° C) Humidity: 0 to 90% non-condensing
Display:	212G: 12 digit, 15 segment, 0.8" high LCD (display) 212GX: 6 digit, 15 segment, 2" high LCD (display) 18 annunciators
Transducer Excitation:	9.4 VDC
Signal Input Range:	1.0 mV min. to 40 mV max. (with dead load boost)
Number of Load Cells:	8 each, 350-ohm load cells
Load Cell Cable Length:	1,500 feet maximum (requires the use of sense lines). Consult factory for other requirements 30 feet maximum without sense lines
Division Value:	Commercial: 1, 2, or 5 x 10, 1, 0.1, 0.01, 0.001 Non-commercial: 1 to 99 x 10, 1, 0.1, 0.01, 0.001.
Sensitivity:	
NON-COMMERCIAL	0.15uV/e
NTEP	0.3uV/e (Class III/IIIL)
CANADA	0.3uV/e (Class III/IIHHD)
Scale Divisions:	
NON-COMMERCIAL	100 to 240,000
NTEP	500 to 10,000 (Class III/IIIL)
CANADA	500 to 10,000 (Class III/IIHHD)
Internal Resolution:	1 part in 16,777,216
Tare Capacity:	Scale Capacity
Sample Rate:	1 to 100 samples per second, selectable
Auto Zero Range:	0.5 or 1 through 9 divisions
Weighing Units:	Pounds/Kilograms
Keypad:	Color coded Membrane type, 24 keys
Standard I/O:	4 ea Serial I/O Ports configured as: 4 ea bi-directional RS-232 ports 1 ea 20mA output-only ports (uses one of the four RS-232 ports) 1 ea bi-directional 20mA port (uses one of the four RS-232 ports) 1 ea USB port (uses one of the four RS-232 ports) 8 ea Remote Isolated Inputs 8 ea Remote Isolated Outputs

Standard Features:

- Push button tare function
- Gross, tare, net conversion
- Selectable key lockout
- Hi-Resolution mode
- StableSENSE®¹ adjustable digital filtering
- Gross and Net accumulators
- Four serial ports
- Eight (8) remote input lines for Zero, Tare, Gross, Units, Start, Stop and Print (1000 feet maximum)
- Programmable print format using Visual Print or nControl (2 Visual Tickets available)
- SMA level 2 compliant serial communications
(For more information see <http://www.scalemanufacturers.org>)
- Field re-programmable via PC interconnection
- Test feature (performs display and internal tests)
- Auto Shutoff and Sleep modes
- Alphanumeric keypad
- Keypad tare function
- Count feature with accumulator
- Time and Date with selectable 12 or 24 hour operation
- Checkweigher
- Eight (8) Preset Weight Comparators
- Axle Weigher (CWL-40) Operation Mode
- Animal Weigher
- ID Storage
- 2-Speed Fill Control
- USB Interface

Optional Features:

Analog Output*, Allen-Bradley Interface*, 10/100 mbps Ethernet Adapter*, Additional Serial Port*, Internal Relay Box*, External Relay Box* and Special Filtering

*This feature requires additional hardware and includes additional documentation.

¹ StableSENSE® is a digital filter utilizing proprietary software algorithms to remove or greatly reduce changes in the weight display resulting from movement on the scale platform. StableSENSE® can be used with livestock and single animal scales to lessen the effects of the animal's movement on the scale or it can be used with vehicle scales to lessen the effects of wind and vehicle vibration. Any application affected by vibration or movement on the scale platform can benefit using StableSENSE®.

PRECAUTIONS

Static Electricity



CAUTION! This device contains static sensitive circuit cards and components. Improper handling of these devices or printed circuit cards can result in damage to or destruction of the component or card. Such actual and/or consequential damage **IS NOT** covered under warranty and is the responsibility of the device owner. Electronic components must be handled only by qualified electronic technicians who follow the guidelines listed below.



WARNING! ALWAYS use a properly grounded wrist strap when handling, removing or installing electronic circuit cards or components. Make certain that the wrist strap ground lead is securely attached to an adequate ground. If you are uncertain of the quality of the ground, you should consult a licensed electrician.



ALWAYS handle printed circuit card assemblies by the outermost edges. **NEVER** touch the components, component leads or connectors. **ALWAYS** observe warning labels on static protective bags and packaging and never remove the card or component from the packaging until ready for use. **ALWAYS** store and transport electronic printed circuit cards and components in anti-static protective bags or packaging.

SITE PREPARATION REQUIREMENTS

The Cardinal 212G/212GX indicators are precision weight-measuring instruments. As with any precision instrument, they require an acceptable environment to operate at peak performance and reliability. This section is provided to assist you in obtaining such an environment.

Environmental

The Model 212G/212GX indicators meet or exceeds all certification requirements within a temperature range of 14 to 104 °F (-10 to +40 °C).

In order to keep cooling requirements to a minimum, the indicator should be placed out of direct sunlight and to provide adequate air circulation, keep the area around the indicator clear.

Make certain the indicator is not directly in front of a heating or cooling vent. Such a location will subject the indicator to sudden temperature changes, which may result in unstable weight readings.

Insure that the indicator has good, clean AC power and is properly grounded.

In areas subject to lightning strikes, additional protection to minimize lightning damage, such as surge suppressors, should be installed.

Electrical Power

The 212G/212GX indicators have been designed to operate from 100 to 240 VAC at 50/60 Hz. Note that a special order is not required for operation at 230/240 VAC.

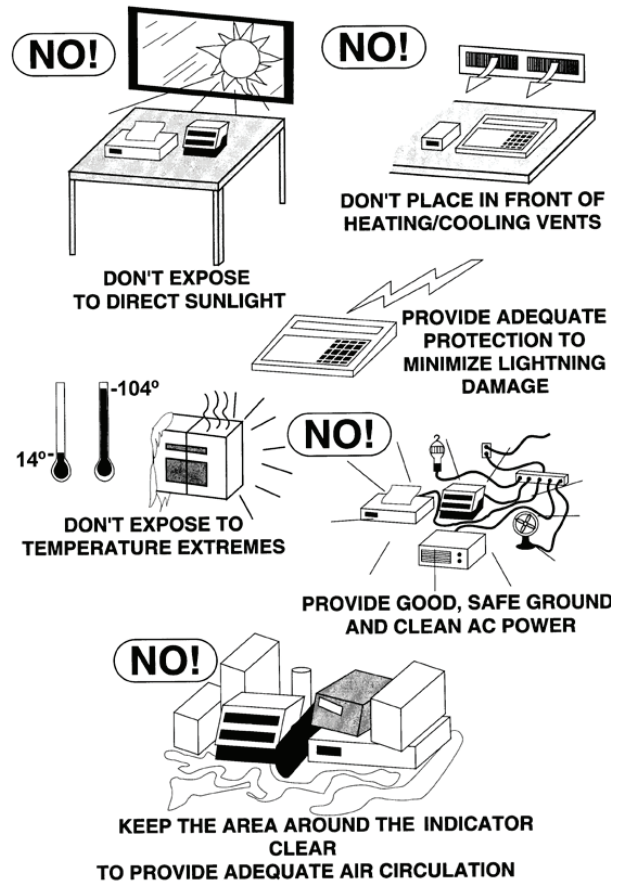

WARNING! To avoid electrical hazard and possible damage to the indicator, **DO NOT**, under any circumstance, cut, remove, alter, or in any way bypass the power cord grounding prong.

- The socket-outlet supplying power to the indicator should be on a separate circuit from the distribution panel and dedicated to the exclusive use of the indicator.
- The socket-outlet shall be installed near the equipment and shall be easily accessible. Note that the power cord on the 212G/212GX serves as the power disconnect.
- The wiring should conform to national and local electrical codes and ordinances and should be approved by the local inspector to assure compliance.
- For outdoor operations, the socket-outlet must provide GFCI (ground fault circuit interrupter) protection.
- On installations requiring 230/240 VAC power, **it is the responsibility of the customer** to have a qualified electrician install the proper power cord plug that conforms to national electrical codes and local codes and ordinances.

Electrical Noise Interference

To prevent electrical noise interference, make certain all other wall outlets for use with air conditioning and heating equipment, lighting or other equipment with heavily inductive loads, such as welders, motors and solenoids are on circuits separate from the indicator. Many of these disturbances originate within the building itself and can seriously affect the operation of the indicator. These sources of disturbances must be identified and steps must be taken to prevent possible adverse effects on the indicator. Examples of available alternatives include isolation transformers, power regulators, uninterruptible power supplies, or simple line filters.

Transient Suppression

The following recommendations will help to reduce transients:

- Always use shielded cables to connect signal wires to the weight indicator.
- Secure the cables in the cable clips provided inside the indicator.
- Connect the cable shield (indicator end only) to a ground point inside the indicator. Keep wires that extend beyond the shield as short as possible.
- Do not run load cell or signal cables from the weight indicator along side or parallel to wiring carrying AC power. If unavoidable, position the load cell and signal cables a minimum of 24" away from all AC wiring.
- Always use arc suppressors across all AC power relay contacts (see recommendations at http://www.paktron.com/pdf/Quencharch_QRL.pdf).
- Use zero voltage switching relays, optically isolated if possible.

RFI Immunity

The operation of sensitive electronic equipment can be adversely affected by RF (Radio Frequency) radio transmissions. Digital weight indicators are one such type of equipment. Radio transmissions come from things like hand-held radio transmitters and cell phones. One symptom of RFI (Radio Frequency Interference) in a digital weight indicator is weight indication instability during a radio transmission.

Cardinal digital weight indicators are designed with special grounding and RFI shielding to achieve a high degree of immunity to common RFI. To maximize the digital weight indicator's immunity to radio transmissions, follow these guidelines:

1. ALWAYS use shielded cable for all I/O (Input/Output) connections to the digital weight indicator.
2. NEVER operate any radio transmitter within 2 meters (~6ft.) of the weight indicator.
3. NEVER connect un-terminated serial, digital, or analog I/O cables to the internal printed circuit boards of the digital weight indicator.
4. KEEP the intended external I/O device connected to I/O cables entering the digital weight indicator.
5. ALWAYS connect the shield of the shielded cable to the indicator back panel gland connector or other closest ground terminal inside the indicator.
6. ALWAYS connect the shield of the shielded I/O cable at the indicator end only. Leave the shield unconnected at the I/O device.

INSTALLATION

Before beginning installation of your 212G/212GX Weight Indicating Instrument, make certain that the instrument has been received in good condition. Carefully remove the instrument from the shipping carton and inspect it for any evidence of damage (such as exterior dents or scratches) that may have taken place during shipment. Keep the carton and packing material for return shipment if it should become necessary. It is the responsibility of the purchaser to file all claims for any damages or loss incurred during transit.

Mounting

The Model 212G/212GX indicators are housed in a thermoplastic enclosure. The gimbal may be mounted on a desktop or other smooth, flat, horizontal surface or may be mounted on a wall. Refer to Figure No. 1 for a layout of wall-mounting bolts.

If wall mounted, make certain the mounting surface is strong enough to support the indicator. The mounting location should be where the display is easily viewed while being close enough to provide the operator easy access to the keypad. Carefully lay out the mounting hole locations, then drill and install the anchor bolts. Attach the gimbal to the wall and securely tighten the retaining bolts.

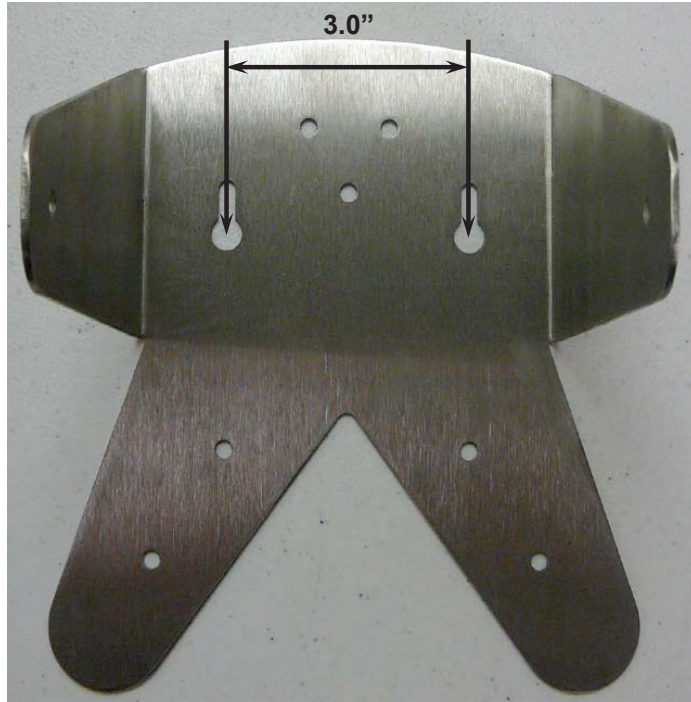

Figure No. 1

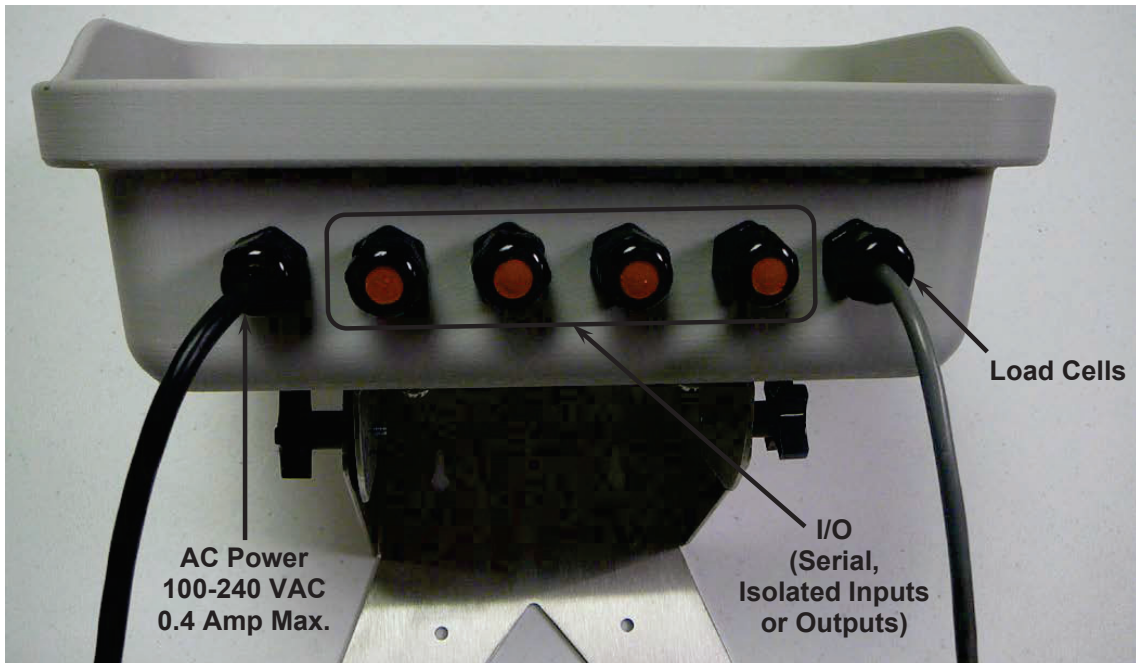

Figure No. 2

Load Cell Connection



WARNING! Disconnect any external load cell power supply before connecting load cells to the indicator. Failure to do so will result in permanent damage to the indicator.

The following instructions describe the load cell connections routing the load cell cable through a standard gland connector. Refer to Figure No. 2 for illustration of connector layout.

1. Remove the 12 mounting screws securing the front panel to the main housing.
2. Referring to Figure No. 2, choose a gland connector for the cable and then loosen it.
3. Slip the single cable from the load cell or load cell junction box through the gland connector and into the enclosure.
4. Referring to Figure No. 3, remove 4 inches of the outer insulation jacket.
5. Next, remove 1/4 inch of insulation from each of the 4 wires and shield (without sense leads) or 6 wires and shield (with sense leads).
6. Referring to the table below (or the circuit board) for terminal connections, connect each of the wires to terminal block P15. Refer to Figure No. 15 for terminal block location.
7. To terminate a wire, use a small flat blade screwdriver and press down on the release bar for the terminal (Figure No. 4). Insert the wire into the terminal opening. Remove the screwdriver, allowing the release bar to return to its original position, locking the wire in place.
8. Repeat the procedure until all of the load cell wires are in place.
9. The shield wire should be connected to terminal 4 of the P15 terminal block connector.

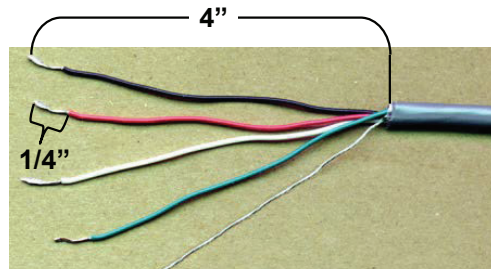

Figure No. 3

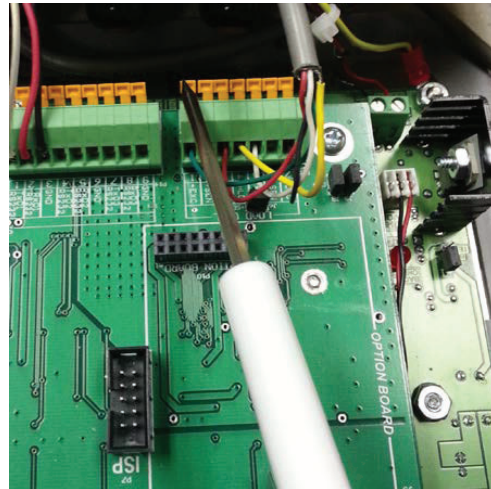

Figure No.4

LOAD CELL TERMINAL BLOCK P15

TERMINAL NO.	Function	TERMINAL NO.	Function
1 – +EXC	+ EXCITATION	5 – -SIG	- SIGNAL
2 – +SEN	+ SENSE*	6 – -SEN	- SENSE*
3 – +SIG	+ SIGNAL	7 – -EXC	- EXCITATION
4 – SHLD	SHIELD (Connect the load cell cable shield wire here).		

*** NOTE:** If the sense leads are NOT used, you must install plug-in jumpers at J6 and J9 adjacent to the terminal block. These jumpers attach the sense leads to the excitation leads. If sense leads ARE used (as in motor truck scales), these plug-in jumpers should be positioned on one plug-in pin only or removed and stored for later use (see Figure No. 15).

Load Cell Connections with Over 30 Feet of Cable

For installations with over 30 feet of cable between the indicator and the load cells, sense wires should be used. The sense wires must be connected between the +SENS, -SENS terminals on the indicator and the +EXCITATION, -EXCITATION wires of the load cells or the +SENS, -SENS terminals of the load cell trim board or the section seal trim board.

Serial I/O Cable Installation

The 212G/212GX indicators may be connected to a printer to record weight and associated data or they may be connected to a remote display or to a computer for transmission of weight data. The weight data may be transmitted on demand (pressing the **PRINT** key or on receipt of a command from the computer). Refer to the Setup, SIO Serial I/O section of this manual.

1. If the front panel of the indicator has been removed, proceed to step 2. Otherwise, remove the 12 screws securing the front panel to main housing.
2. Loosen the gland connector for the serial cable. Refer to Figure No. 2 for the gland connector layout.
3. Slip the serial cable through the gland connector and into the enclosure.
4. Remove 2" of the outer insulation jacket then remove 1/4" of insulation from each of the wires (refer to the Figure No. 6).
5. Connect each of the wires to the Serial Data terminal block (P13 and P14) referring to Figure No. 15 for terminal block locations.
6. To terminate, first press down on the release bar for the terminal, insert the wire into the opening then allow the release bar to return to its original position, locking the wire in place. Repeat the procedure until all of the wires are in place.

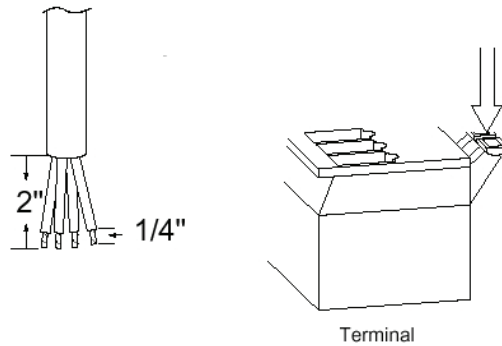

Figure No. 6

BI-DIRECTIONAL SERIAL INTERFACE

TERMINAL (P14)	
PIN NO.	Function
1	TxD1-RS232
2	RxD1-RS232
3	GND
4	TxD2-RS232
5	RxD2-RS232
6	GND
7	TxD3-RS232
8	RxD3-RS232
9	GND

TERMINAL (P13)	
PIN NO.	Function
1	+20mA SRC
2	RxD0-SRC
3	RxD0-20mA+
4	RxD0-20mA-
5	TxD0-SRC
6	TxD0-20mA+
7	TxD0-20mA-
8	TxD1-20mA+
9	TxD1-20mA-
10	GND
11	TxD0-RS232
12	RxD0-RS232
13	GND

Interconnect Wiring for 20mA Current Loop Operation

Peripheral Device has **ACTIVE END** of Current Loop.

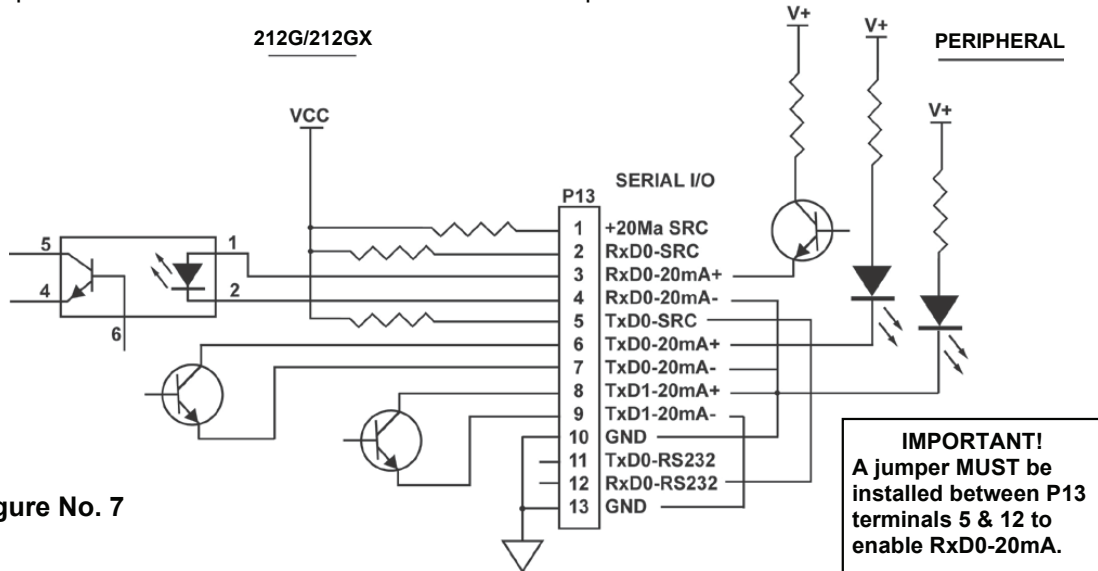

Figure No. 7

Interconnect Wiring for 20mA Current Loop Operation

Peripheral Device has **PASSIVE END** of Current Loop.

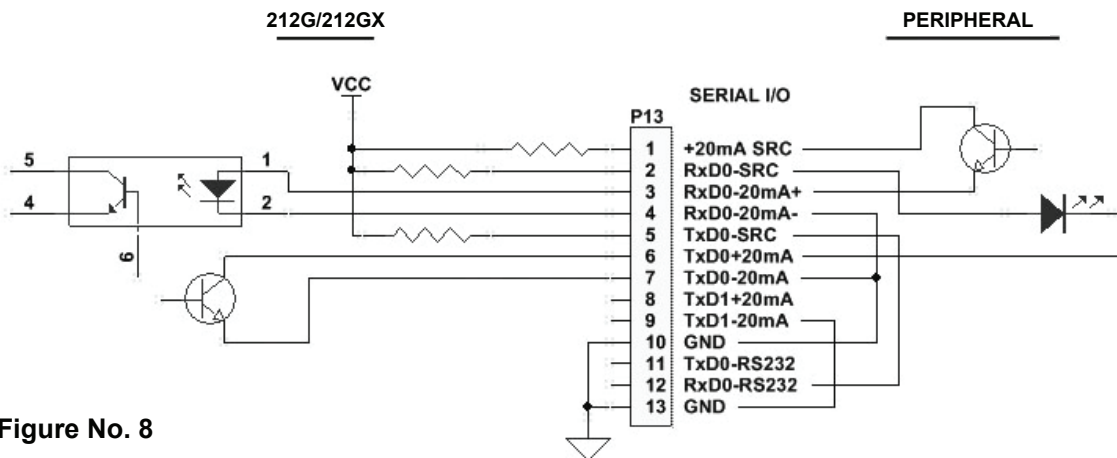

Figure No. 8

PORT	RS-232	20mA	USB
TXD0	X	X	
RXD0	X	X	
TXD1	X	X	
RXD1	X		
TXD2	X		
RXD2	X		
TXD3	*X		*X
RXD3	**X		**X

* Mutually exclusive

** Mutually exclusive

USB Interface

The 212G/212GX indicator USB Interface is a standard full speed (12Mbps) USB 2.0 device port. It can be connected to a USB 2.0 host, with the Cardinal Scale 8200-B163-0A USB CABLE or an industry standard USB 2.0 cable, to be used as the COM3 serial I/O port set to 8 bit data, 1 stop bit, no parity, 9600 to 115.2k baud. Refer to the Setup, SIO Serial I/O section of this manual.

The USB port is enabled with jumpers J4 and J5 (see Figure No. 15) set to the USB position (utilizing the indicator COM3 serial port) and the USB PWR jumper, J10 (see Figure No. 15), set to the BUS position to be powered by the USB host or to the VCC position to be powered by the 212G/212GX indicator main PC board. Follow the “Driver Installation Instructions for Indicator’s USB Port” in conjunction with the usb2ser.inf file located on the 212G/212GX Indicator Installation and Technical Manual CD.

USB Cable Installation

8200-B163-0A Water Tight USB Cable Installation

1. Remove the 12 screws securing the front panel to main housing.
2. Remove a gland connector from the back panel. Refer to Figure No. 2 for illustration of connector layout.
3. Loosen the gland connector nut from the 8200-B163-0A cable/gland assembly (see Figure No. 9) and slip off over the 5-pin cable connector and ground wire.
4. Insert the 5-pin connector and ground wire through the rear panel.
5. Slip the gland connector nut back over the 5-pin connector and ground wire and tighten on the gland connector on the rear panel.
6. Pull the USB cable through the gland to reach P4, the USB-B header.
7. Plug the USB cable connector onto the USB-B, P4 header, referring to Figure No. 15 for the location of P4. Tighten the gland cable nut on the USB cable.

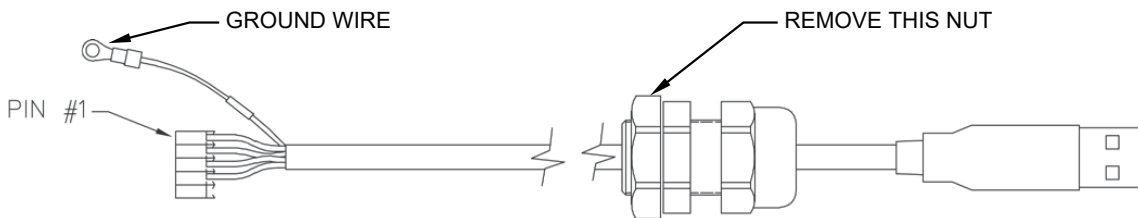

Figure No.9

8. To attach the ground wire (see Figure No.9); remove a 6-32 nut and washer from the corner of the main board.
9. Connect the ground wire from the USB cable by placing the ring terminal over the 6-32 threaded stud.
10. Reinstall the washer and 6-32 nut and tighten.

Standard USB Cable Installation

1. Remove the 12 screws securing the front panel to main housing.
2. Remove a gland connector from the back panel. Refer to Figure No. 2 for illustration of connector layout.
3. Slip the cable through the hole in the rear panel and into the enclosure.
4. Plug the USB cable into the USB-B connector P6. See Figure No. 15 for the location of P6.

Main PC Board I/O Functions Table

Refer to Figure No. 10 for the AC Input Relay board, Figure No. 11 for the AC Output Relay board, Figure No. 13 for the RB4C Relay board and Figure No. 15 for the Main PCB.

INPUTS		OUTPUTS				
		PWC		CHECKWEIGHER	DFC	
P3	FUNCTION	P2	Presets	Check 3	Fill 1	Fill 2
2	GROSS/NET	2	PWC 1	UNDER	Fill	Fast Slow Dump
3	PRINT	3	PWC 2	ACCEPT		
4	ZERO	4	PWC 3	OVER		
5	TARE	5	PWC 4			
6	*	6	PWC 5			
7	UNITS	7	PWC 6			
8	START	8	PWC 7			
9	STOP	9	PWC 8			

RB4/RB8 Relay Box Cable Wire Number to Relay Number Table

The relay box cable wire numbers correspond to the indicator main PC board remote input (P3) and output (P2) terminal connection pins.

CABLE WIRE NUMBER	RELAY NUMBER (Set Proper Jumpers)	CABLE WIRE NUMBER	RELAY NUMBER (Set Proper Jumpers)
1	+SRC (For AC Input Relays)	6	5
2	1	7	6
3	2	8	7
4	3	9	8
5	4	10	GND

Optically Isolated Remote Inputs

Included with the I/O are 4 programmable inputs that may be used to remotely (up to 100 feet) initiate various functions within the indicator. These inputs are accessed via a terminal block (P3) on the back of the PC board (see Figure No. 15). The 8 inputs are defined as follows:

<u>TERMINAL NO.</u>	<u>Function</u>
1	SRC 12-24VDC
2	Gross
3	Print
4	Zero
5	Tare
6	*
7	UNITS
8	START
9	STOP
10	GND

NOTE: The input must be momentarily connected to GND to initiate the function.

AC Input Relay Board(s)

The AC Input Relay Board(s) are mounted in an external junction box for use with the 212G/212GX Indicator. The RB4-ACIN (115 VAC) or RB4-ACINV (230 VAC) contain one board and supports 4 inputs (jumper selectable). The RB8-ACIN (115 VAC) or RB8-ACINV (230 VAC) contain two boards and supports seven inputs that are jumper selectable. The relay board used in the 115 VAC versions is Cardinal p/n 8200-C324-0A. The 230 VAC version uses relay board Cardinal p/n 8200-C324-1A. Connect the devices as shown in Figure No. 10.

INPUT RELAY TYPE IAC-5	90 to 140 VAC @ 6mA maximum for each plug-in relay
INPUT RELAY TYPE IAC-5A	180 to 280 VAC @ 6mA maximum for each plug-in relay
OUTPUT	5VDC @ 12mA from the 225 main pc board assembly P9 12VDC @ 12mA maximum from external source
CONNECTION	Removable plug-in screw terminals for up to 14 AWG wire

AC Input Relay Board(s), Cont.

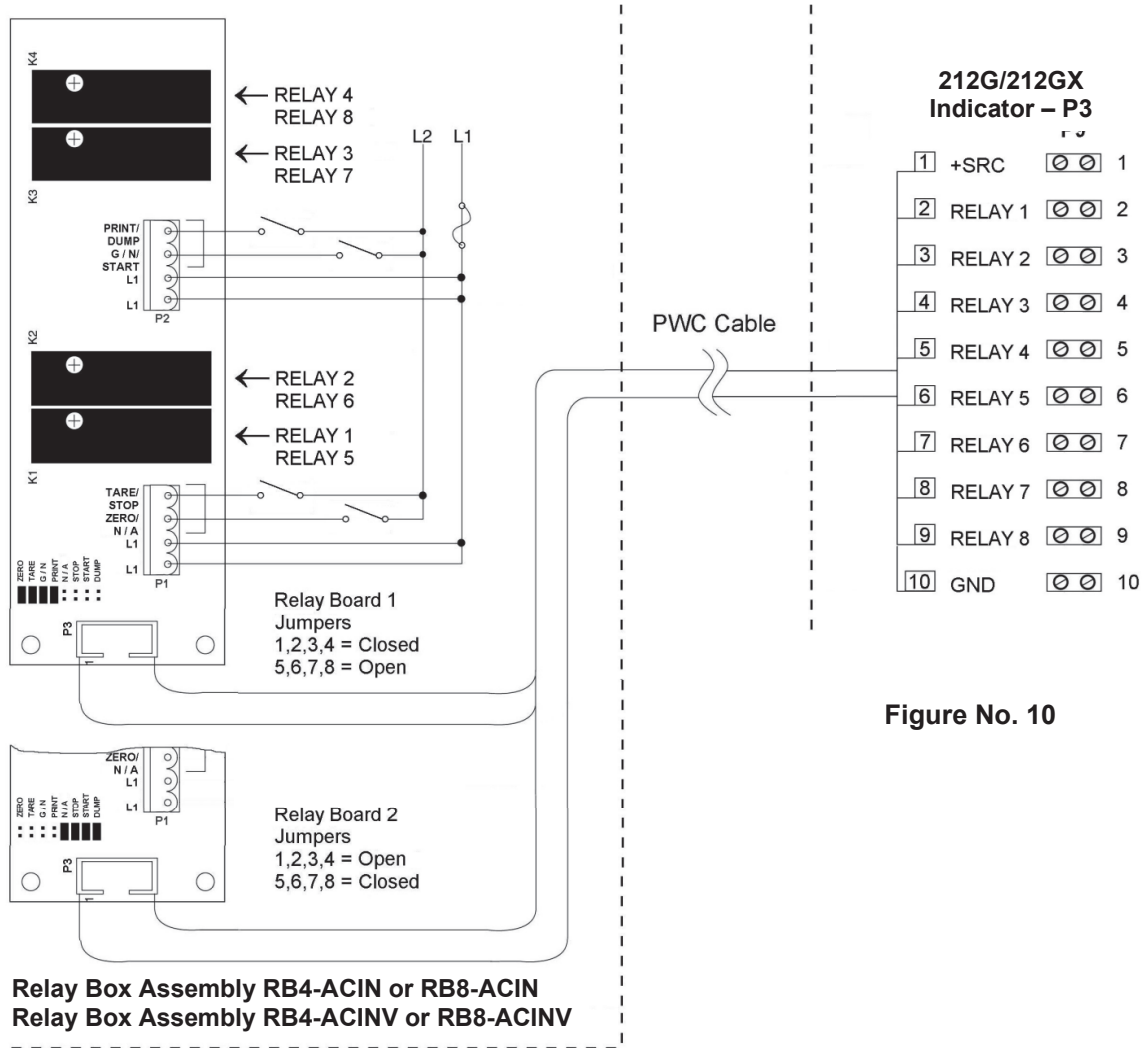

Figure No. 10



WARNING! AC input relays are voltage dependent. A different relay is required for 115 VAC and 230 VAC.

Preset Weight Comparator/Checkweigher Logic Level Output

If you so choose, you may use the logic level outputs from your Model 212G/212GX indicator's preset weight comparators or checkweigher to control peripheral devices used to manage the flow of material or signal when the weight is within preset limits. Note that these outputs are at logic level and cannot drive external devices directly, with the exception of the Cardinal 2XX-OU Check Weigher Light Bar. Solid-state relays can be used to accept the logic level output from the 212G/212GX and in turn, drive other external devices.

J7 (VP/VCC) - REMOTE OUT SRC (SOURCE) JUMPER

The Remote Output SRC jumper J7, when connected, allows the 212G/212GX indicator to supply (source) VP (15VDC) or VCC (5vdc) to a solid-state relay or other load of 200 ohms or greater. The positive connection from the relays must be connected to the PWC connector negative wire from the relays to the GND pin. See Figure No. 15 for jumper and REMOTE OUTPUTS connector location.

For completely isolated outputs, J7 must be open (positioned on one plug-in pin only or removed) and the user must provide 12 to 24 VDC to the SRC pin and a ground return to the load. The load must still be 200 ohms or greater.

To connect the control cable to the preset weight comparator/checkweigher logic level output connector P2:

1. If the front panel of the indicator has been removed, proceed to step 2. Otherwise, remove the 12 screws securing the front panel to main housing
2. Loosen the gland connector for the cable. Refer to Figure No. 2 for the gland connector layout.
3. Slip the cable through the gland connector and into the enclosure.
4. Remove 2 inches of the outer insulation jacket
5. Next, remove 1/4 inch of insulation from each of the wires.
6. Connect each of the wires to the REMOTE OUTPUTS terminal block (P10) referring to Figure No. 15 for terminal block locations.
7. To terminate a wire, use a small flat blade screwdriver and press down on the release bar for the terminal. Insert the wire into the terminal opening. Remove the screwdriver, allowing the release bar to return to its original position, locking the wire in place.
8. Repeat procedure until all wires are in place.

AC Output Relay Board(s)

The AC Output Relay Boards are mounted in an external junction box for use with the 225 Indicator and can be purchased from Cardinal. The RB4-ACOUT contains one board and supports four outputs (jumper selectable). The RB8-ACOUT contains two boards and supports eight outputs. The relay board used in both is (Cardinal p/n 8539-C062-0A). Connect the devices to be controlled as shown in Figure No. 11.

The individual relays can be configured to be on (closed) or off (open) at weights under the preset weight then switch at the preset weight from on-to-off or off-to-on by setting the under weight condition to on or off during setup and calibration or setup review.

OUTPUT (closed)	28-240VAC @ 3A maximum for each plug-in relay
CONTROL INPUT	5VDC @ 12mA from the 225 main pc board assembly P2
CONNECTION	Removable plug-in screw terminals for up to 14 AWG wire

NOTE: All relays are the normally-open type that will open when power to the indicator is lost.

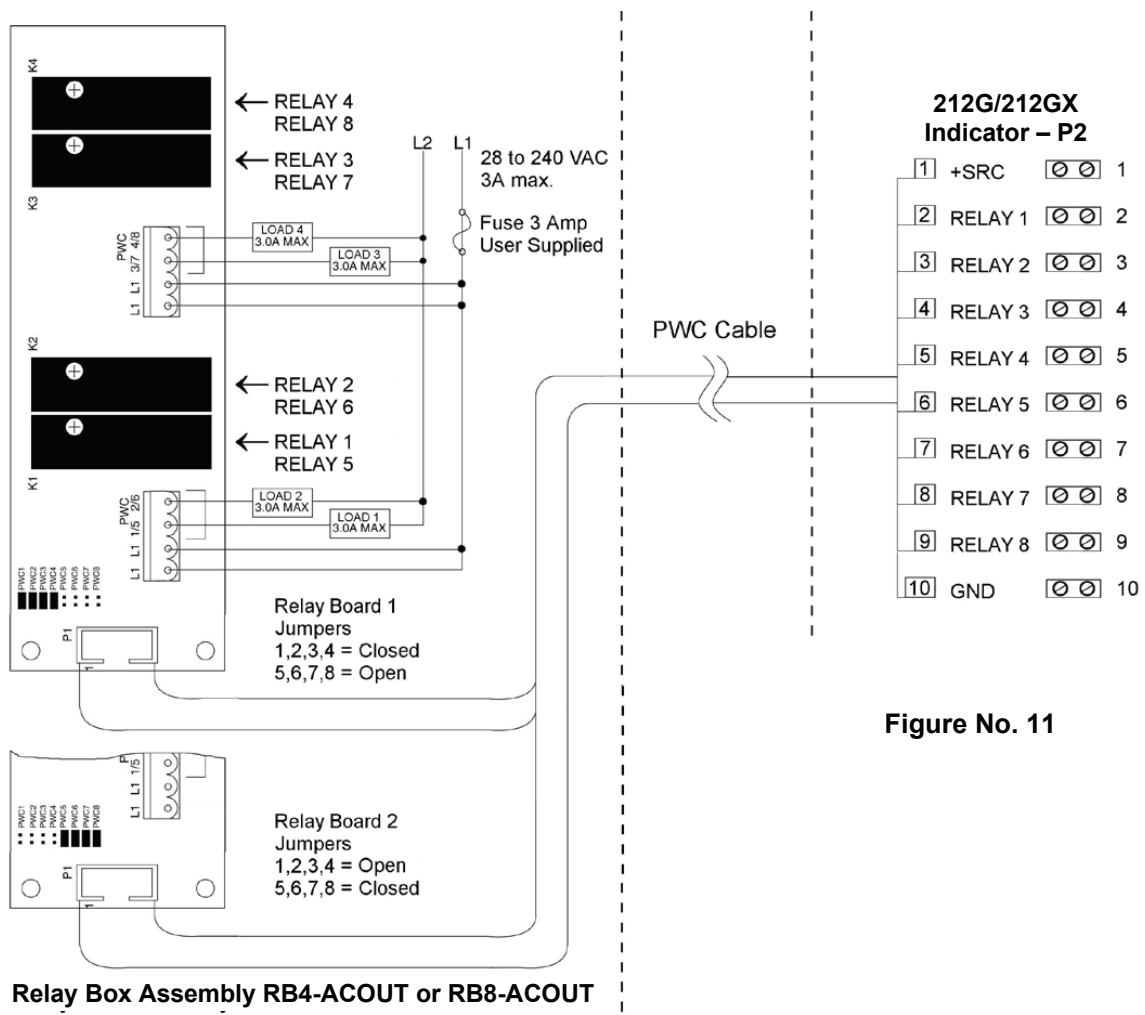

Figure No. 11

RB4C Relay J-BOX

The RB4C provides four FORM-C, SPDT (one normally open and one normally closed), 24-250 volt (AC or DC), 3A mechanical relays to control external devices from a digital weight indicator equipped with output control. The output control can be 5-15VDC, 1mA source or 20mA current sink. The source (SRC) or sink (SINK) type is selected with the Relay Control Source Type Jumpers, J1, J2, J3, and J4 (see Figure No. 12), one for each relay.

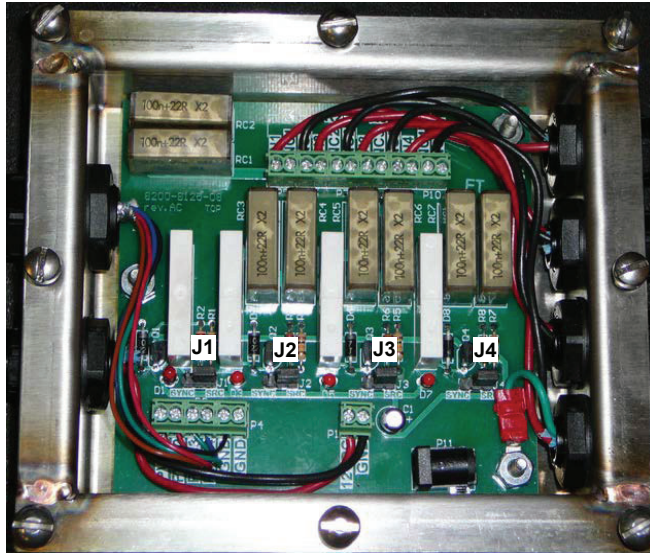

Figure No. 12
(Relay Control Source Type Jumpers)

RB4C Output Relay Wiring Example

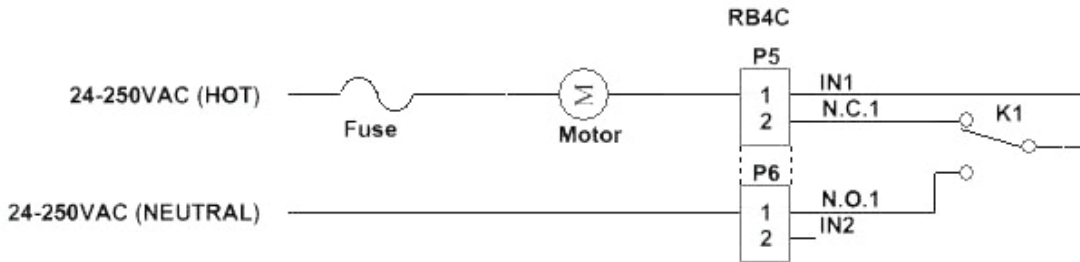

Figure No. 13

RB4C Control Circuit Wiring Example

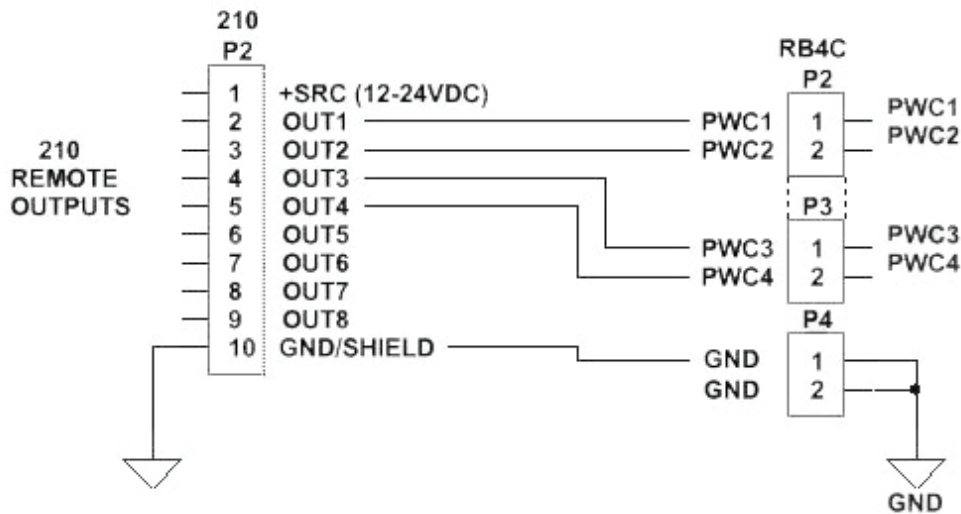

Figure No. 14

Main PCB

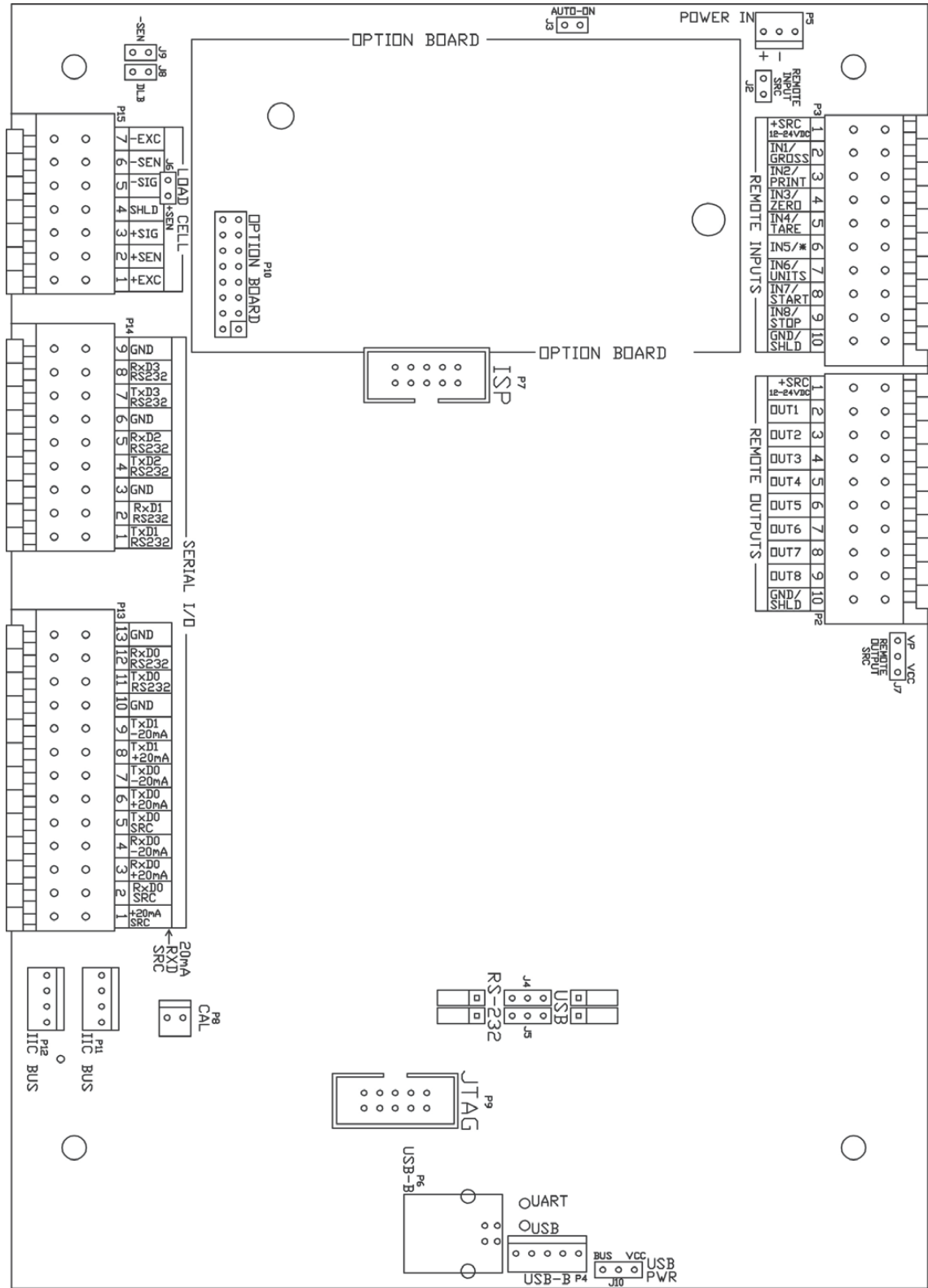

Figure No. 15

Main PCB Jumpers

J2 – REMOTE INPUT SRC (SOURCE)

The Remote Input SRC jumper J2, when connected, allows the 212G/212GX indicator to supply (source) 12-24VDC to a solid-state relay or other load of 200 ohms or greater. The positive connection from the relays must be connected to the remote input connector pins and the negative wire from the relays to the GND/SHLD pin.

J3 – AUTO-ON JUMPER

The AUTO-ON jumper J3, when connected, will cause the indicator to power on automatically whenever power is applied to the power input connector. If power is lost momentarily and then reapplied, the indicator will turn on without pressing the **ON/OFF** key.

J4 AND J5 – RS-232/USB PORT

These jumpers control whether COM3 is RS-232 and uses Serial I/O P14 (pins 7, 8, & 9) or USB and uses the USB-B header, P4 or USB-B port, P6.

J6 (+SEN) AND J9 (-SEN) – SENSE JUMPERS

If the sense leads are NOT used, you must install plug-in jumpers at J6 and J9 adjacent to the terminal block. These jumpers attach the sense leads to the excitation leads. If sense leads ARE used (as in motor truck scales), these plug-in jumpers should be positioned on one plug-in pin only or removed and stored for later use.

J8 – DLB (DEAD LOAD BOOST JUMPER)

For very low dead loads (less than 10% of the combined load cell capacity) connect the dead load boost jumper J8 on the printed circuit board.

J7 – REMOTE OUTPUT SRC (SOURCE)

The Remote Output SRC jumper J7, when connected, allows the 212G/212GX indicator to supply (source) VP (15VDC) or VCC (5vdc) to a solid-state relay or other load of 200 ohms or greater. The positive connection from the relays must be connected to the remote output connector pins and the negative wire from the relays to the GND/SHLD pin.

J10 – USB PWR

The USB PWR jumper J10 selects whether the USB power is provided by the USB Host (set to BUS position) or by the 212G/212GX indicator (set to VCC position).

Re-Installing the Front panel

After all terminations have been made;

1. Remove the excess cable from the instrument enclosure and securely tighten each of the cable gland connectors.
 - Do not over-tighten these connectors but make certain they are snug.
 - **DO NOT USE TOOLS!** Finger-tighten only!
 - Insure any unused gland connectors are plugged.
2. Make certain no cables or wires are exposed between the main housing and front panel
3. Place the front panel onto the main housing.
4. Secure with the 12 mounting screws removed earlier.
5. Follow a diagonal pattern when tightening the screws.

KEYPAD FUNCTIONS

The Model 212G/212GX is equipped with a 24-key keypad. The keypad is used to enter commands and data into the instrument. This section describes each key along with its normal function. It is helpful to refer to the actual instrument while reading this section.

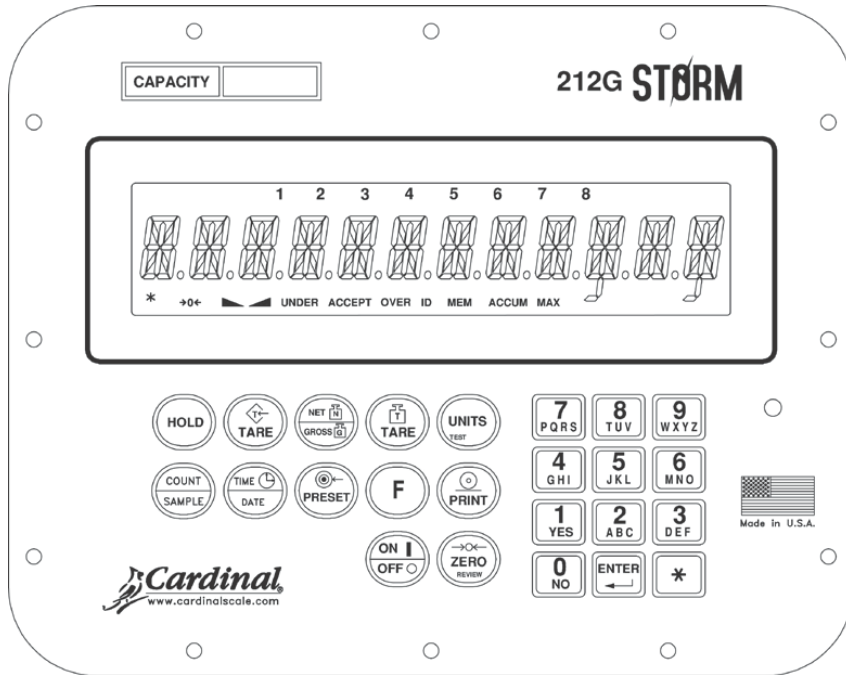

Figure No. 16 (212G)

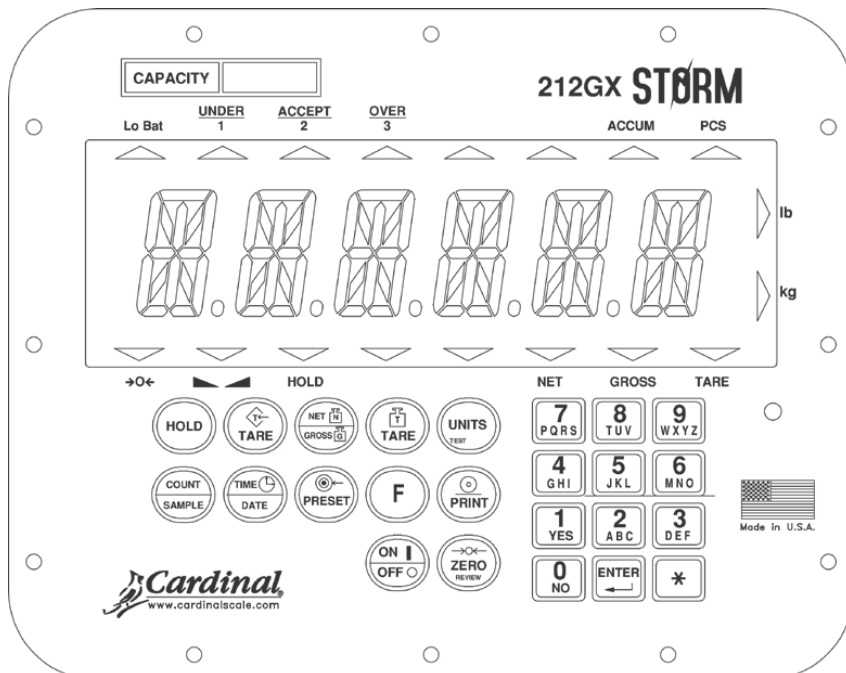

Figure No. 17 (212GX)



DO NOT operate the keypad with pointed objects (pencils, pens, etc).
Damage to keypad resulting from this practice is **NOT** covered under warranty.

HOLD KEY

Pressing the HOLD key will lock the weight and display *HOLD* on the right for the 0.8" LCD display and turn on the HOLD annunciator on the 2" display. The HOLD is only available if *LFT=NO* in *SETUP*.

TARE KEY (WITH DIAMOND "T" SYMBOL)

This is a dual function key. Pressing the **TARE** key alone (Pushbutton Tare mode) will store the current gross weight as a new tare weight and cause the weight display to change to the net weight display mode [**NET** annunciator (212GX) or **N** next to the weight display (212G)]. Pressing the key after entering a numeric value (Keypad Tare) will cause the value entered to be accepted as a new tare weight.

NOTE: Tare weights equal to or greater than scale capacity cannot be entered. In addition, keypad tare weight division value must be same as scale division value. For example, a unit with .005 lb as division value will display *-ERROR* if you enter 1.003 for tare weight.

NET/GROSS KEY

This key is used to toggle between the Net and Gross weight modes. The selected mode is indicated by turning on the **NET** or **GROSS** annunciator on the display. Note that if no valid tare weight has been entered, pressing this key will cause a momentary *NOTARE* display error and the indicator will remain in the Gross weight mode.

TARE KEY (WITH WEIGHT "T" SYMBOL)

Pressing this key will display the current tare weight for three seconds.

UNITS/TEST KEY

This key performs two functions. In normal operation, it is used to select the units in which the weight is to be displayed. The available units of measure ("unit1" and "unit2") are enabled or disabled in setup. The available units include tons, pounds, ounces, tonnes (metric tons), kilograms, and grams. Note that not all combinations are supported. Pressing this key after the * key will enter the Test mode. The Test mode is used to conduct a test of all display elements. Refer to description of * key for details.

COUNT/SAMPLE KEY

This key performs two functions. The first time it is pressed, the indicator will count (unless piece weight is 0). The second time it is pressed (or if *PCWT=0* on the first press) will show the prompt *RDD=5* on the display. Continued pressing of the **COUNT/SAMPLE** key will toggle between the *RDD=5, 10, 25, 50, 75* prompts to select a sample size. When desired sample size is displayed, press the **ENTER** key **OR** with *RDD= (5, 10 etc.)* displayed, using the numeric keypad, key-in any desired sample value, then press the **ENTER** key. Press the * key to abort the input operation. To exit the count function and display weight, press the **NET/GROSS** key.

TIME/DATE KEY

This key is used to enter the clock mode to program the time, date and consecutive number. Pressing the **TIME/DATE** key will enter the clock mode with the 212G/212GX displaying *HOUR=*.

12-Hour Format Selected In Setup (*TD=12*)

1. With the display showing *HOUR=*, press the **ENTER** key.
2. If the time displayed is correct, press the **ENTER** key and proceed to step 4.
3. If the displayed time is incorrect, use the numeric keys to enter the correct time and press the **ENTER** key.
4. The display will change to *R=*. Press the **ENTER** key.
5. The display will show *YES*.
 - If the time is before noon (12:00 PM), press the **ENTER** key.
 - If the time is after noon (12:00 PM), press the **0/NO** key, then press the **ENTER** key.
6. The display will show *DATE=*. Press the **ENTER** key.
7. If the date displayed is correct, press the **ENTER** key to proceed to the consecutive number prompt, *CNC N=*.
8. If the date displayed is incorrect, use the numeric keys to enter the correct date and press the **ENTER** key to proceed to the consecutive number prompt. Remember to enter the date in the same format (month-day-year or day-month-year) as selected by the *USA* setup parameter. Note that with the *USA=YES* setting, the date format is month-day-year.

24-Hour Format Selected In Setup (*TD=24*)

1. With the display showing *HOUR=*, press the **ENTER** key.
2. If the time displayed is correct, press the **ENTER** key and proceed to step 4.
3. If the displayed time is incorrect, use the numeric keys to enter the correct time and press the **ENTER** key. Note that with the 24-hour format selected, entering all times after noon (12:00 PM), you must add 12 to the time, i.e. 3 PM would be 1500.
4. The display will show *DATE=*. Press the **ENTER** key.
5. If the date displayed is correct, press the **ENTER** key to proceed to the consecutive number prompt, *CNC N=*.
6. If the date displayed is incorrect, use the numeric keys to enter the correct date and press the **ENTER** key to proceed to the consecutive number prompt. Remember to enter the date in the same format (month-day-year or day-month-year) as selected by the *USA* setup parameter. Note that with the *USA=YES* setting, the date format is month-day-year.

Consecutive Number

Consecutive Number is a printable number (see PRINT TABS in SETUP AND CALIBRATION section) corresponding to the number of consecutive weighments that have been printed. The consecutive number is incremented (if not set to "0") every time a weight is printed. The consecutive number will be reset to the number entered at the *CNC N=* prompt.

If the consecutive number displayed is correct, press the **ENTER** key to resume normal operation. If the consecutive number displayed is incorrect, use the numeric keys to enter the correct consecutive number (up to 6 digits) and press the **ENTER** key to resume normal operation.

PRESET KEY

This key is used to perform numerous functions. Note that the various functions of this key are dependent upon the selected Mode of Operation setting. Those functions are as follows:

ID Storage (*OPER=1*)

If the setup parameter *ALARM?* is YES, the *ALRR WT* prompt will be displayed. Press the **ENTER** key and the alarm weight value will be displayed. If the value is acceptable, press the **ENTER** key, otherwise, use the numeric keys to enter the new alarm weight value and press the **ENTER** key.

The *ALR TI* prompt will be displayed, press the **ENTER** to display the number of seconds that the alarm output (PWC1) is to be turned on when the scale weight exceeds the alarm weight. The alarm time can be from 0 to 99 seconds.

Digital Fill Control (*OPER=2*)

If *STOR* is enabled (*STOR=YES*), you will first be prompted for the stored preset ID (*STOR=*). Press the **ENTER** key to see the current ID. If it is correct then press the **ENTER** key, otherwise enter the desired stored preset ID to be recalled from memory and press the **ENTER** key.

Single Speed operation: (*SPEED=1*)

The *FILL =* prompt is displayed, press the **ENTER** key. The fill weight value is displayed, if the value is acceptable, press the **ENTER** key, otherwise, use the numeric keys to enter the new fill weight value and press the **ENTER** key.

The *TRIM =* prompt is displayed, press the **ENTER** key. The trim weight value is displayed, if the value is acceptable, press the **ENTER** key, otherwise, use the numeric keys to enter the new trim weight value and press the **ENTER** key.

Two Speed operation: (*SPEED=2*)

The *FAST =* prompt is displayed, press the **ENTER** key. The fast weight value is displayed, if the value is acceptable, press the **ENTER** key, otherwise, use the numeric keys to enter the new fast weight value and press the **ENTER** key.

The *SLOW =* prompt is displayed, press the **ENTER** key. The slow weight value is displayed, if the value is acceptable, press the **ENTER** key, otherwise, use the numeric keys to enter the new slow weight value and press the **ENTER** key.

The *TRIM =* prompt is displayed, press the **ENTER** key. The trim weight value is displayed, if the value is acceptable, press the **ENTER** key, otherwise, use the numeric keys to enter the new trim weight value and press the **ENTER** key.

If the *GATE* sequence is set to 3 (chatter-gate), the *CT ON=* prompt will be displayed; press the **ENTER** key. The chatter-gate on time is displayed, if the value is acceptable, press the **ENTER** key, otherwise, use the numeric keys to enter the new chatter-gate time and press the **ENTER** key.

If *STOR* is enabled (*STOR=YES*), you can store/modify a permanently stored preset ID by pressing the * key followed by the **PRESET** key, then enter the desired stored preset ID (*STOR=?*) then press the **ENTER** key.

Preset Weight Comparator (*OPER=3*)

If the Preset Weight Comparator mode of operation (*OPER=3*) was selected, the *PSET1=* prompt will be displayed. Press the **ENTER** key and the currently stored weight value for PRESET #1 will be displayed. If the value displayed is acceptable, press the **ENTER** key, otherwise, use the numeric keys to enter the new preset value and press the **ENTER** key.

- The setup parameter *OPER=3, POUT=*, determines the number of preset weight comparators that will be displayed and prompted for.
- There can be up to 8 Preset weight comparators.

Checkweigher (*OPER=4*)

If the Checkweigher feature was selected and the **PRESET** key pressed, the ACCEPT and UNDER annunciators will flash and the preset value for the minimum acceptable weight will be displayed. Press the **ENTER** key if the displayed value is correct or use the numeric keys and enter the new value and press the **ENTER** key. The ACCEPT and OVER annunciators will now flash and the display will show the minimum value of weight over the accepted range. As before, if the value shown is correct, press the **ENTER** key. If the value is incorrect, enter the new value and press the **ENTER** key to save it. Note that this value must be greater than the accept value. Remember that both the preset weight comparators and checkweigher functions operate on the absolute value of weight ignoring the polarity. After the second preset value is entered, the indicator will return to normal operation.

F KEY

This key is used to perform numerous functions. Pressing the * and then the **F** key will display the light reading from the display board. Press **ENTER** to set the light set point. Pressing it key by itself will display *ERROR*. Note that the additional functions of the **F** key are dependent upon the selected Mode of Operation setting. Those functions are as follows:

OPER = 1 ID Storage

This key initiates a weigh-in or weigh-out operation.

Press the **F** key and enter the ID at the *ID=* prompt. To store/modify a permanent ID, press the * key followed by the **F** key, then enter the desired ID at the *id=* prompt.

OPER = 2 Digital Fill Control

This key will start or pause a digital fill.

1. With the DFC in an idle state, press the **F** key to start the fill.
2. While filling, press the **F** key to pause the fill.
3. While paused, press the **F** key to resume or abort the fill. The indicator will prompt whether or not to continue filling (*CONT = yes/no*).

If the DFC is setup for manual dumping, press the **F** key to initiate a dump after a fill is completed.

OPER = 6 Livestock Weigher

This key will allow you to input a head count (*COUNT =*) for the next ticket to be printed. Once prompted, press the **ENTER** key to display the current head count. Use the numeric keys to select the new head count (1-255) and then press the **ENTER** key to accept it. The value you entered will appear on the next ticket that is printed.

PRINT KEY

Pressing this key will initiate the transmission of weight and other data via the selected printer output port (see *PORT=* under Print menu). The first gross or net weight printed after the gross weight has returned to “zero” will be added to the associated accumulator, and the consecutive number will be incremented.

If the *ID=* (ID Prompt) has been enabled during setup, when the **PRINT** key is pressed, the indicator will prompt for an ID to be printed on the ticket.

If the *A CLR=* is set to 1 (Yes), input up to 6 digits for the ID and then press the **ENTER** key to complete the transaction. Upon pressing the **ENTER** key, the print function will occur.

If the *A CLR=* is set to 0 (no), press the **ENTER** key to display the current ID. If ID displayed is acceptable, press the **ENTER** key again to complete transaction. Otherwise, input up to 6 digits for ID then press the **ENTER** key to complete the transaction. The print function will occur after the **ENTER** key is pressed.

Note that the indicator will not respond to the Print command unless the weight display is stable. If displaying gross weight, the only weight printed is gross weight. If displaying net weight, the gross, tare, and net weights are printed.

The 212G/212GX includes support for visual tickets. Visual tickets are designed by the PC based programs Visual Print or nControl, then downloaded to the indicator. Two programmable formats in addition to the standard print tab settings are allowed.

Print formats are selected by using the * and **PRINT** keys in combination (refer to the * key, * and **PRINT** key section for details).

```
#2
10:19 12/13/2012
100.00 lb G
20.00 lb T
80.00 lb N
0.00 lb GROSS ACCUM
272.00 lb NET ACCUM
```

TICKET EXAMPLE

NOTE: When the **PRINT** key is pressed, the indicator looks for the selected format. If a visual ticket is not found it reverts to the print tab settings.

ON/OFF KEY

This key performs two functions. Pressing it when the indicator is off will apply power to the instrument. If the indicator is already on, pressing this key will turn the indicator off.

ZERO/REVIEW KEY

This key performs two functions. In normal operation, pressing this key will cause an immediate zeroing of the weight display up to the selected limit of 4% or 100% of the scale's capacity. Note that this selection is made during the setup and calibration of the instrument. Pressing this key after the * key will enter the Review mode of Setup and Calibration. Refer to description of * key and the Setup Review section of this manual for details.

0 THROUGH 9, A THROUGH Z KEYS

These keys are used to enter alphanumeric data during the setup and calibration as well as during normal operation of the indicator.

NOTE: The **1** and **0** keys have dual functions. They are used to enter numeric data during setup and calibration as well as during normal operations and are also used to answer yes (1 = YES) or no (0 = NO) to various prompts.

Where allowed, (ID entry), letters are entered by pressing the key in succession until the desired letter is displayed. This is similar to the way a cell phone keypad operates. (Ex: If you want to enter the letter C, you would need to press the **2** key four times).



ENTER KEY

This key serves two purposes. First, when reviewing setup parameters, pressing the **ENTER** key will display the current setting of the parameter. Second, the **ENTER** key is used to signal completion of the entry of data and causes the indicator to process the data entered.

* (ASTERISK) KEY

This key is used for several functions. During Setup, when a setup parameter (not a parameter value) is displayed, pressing it key will "backup" to the previous prompt.

In normal operation, pressing the * key will display *FUNC=*. Pressing the associated key listed below will enable additional features. These features and their associated key combinations are as follows:

* AND 1/0 KEY

This combination is used to adjust the brightness of the weight display. Refer to Display Brightness section of this manual for details.

* AND ZERO/REVIEW KEY

This combination will enter the Review mode of Setup and Calibration. Refer to Setup Review section of this manual for details.

* AND NET/GROSS KEY

This combination will display the Net accumulator.

* AND NET/GROSS KEY, PRINT KEY

This combination will print the Net accumulator.

* AND NET/GROSS KEY, ZERO KEY

This combination will zero (clear) the Net accumulator.

* AND NET/GROSS KEY, NET/GROSS KEY

This combination will display the Gross accumulator.

* AND NET/GROSS KEY, NET/GROSS KEY, PRINT KEY

This combination will print the Gross accumulator.

* AND NET/GROSS KEY, NET/GROSS KEY, ZERO KEY

This combination will zero (clear) the Gross accumulator.

*** AND UNITS KEY**

This combination will enter the Test mode. The Test mode is used to test of all the display elements. It consists of five (5) cycles, each lasting about one (1) second:

1. All horizontal segments will turn on (no annunciators).
2. All vertical segments and decimal points will turn on (no annunciators).
3. All annunciators will turn on.
4. All display elements off.
5. The model number (212G/212GX) and the software version X.X.
6. The calibration numbers (C1 to C4).

*** AND PRINT KEY**

This combination is used to change the selected print ticket format. Pressing the * and then the **PRINT** key will display a prompt *PRT=*. Press the **ENTER** key to show the current value. If the setting displayed is acceptable, press the **ENTER** key again to save it. Otherwise, using the numeric keys enter the new setting and then press the **ENTER** key to save it. Allowable values are:

0 = print tab settings **1** = visual ticket format 1 **2** = visual ticket format 2

In addition to using the * and **PRINT** key combination to change the print ticket format, the operator (just prior to printing the ticket) can change the print ticket format at the end of the weighing operation. This is accomplished by performing the normal weighing operation and then pressing the desired format number (0, 1 or 2), followed by pressing the **PRINT** key.

NOTE: When a print format is selected (by either method), it will remain active until changed by the operator.

ANNUNCIATORS

The 212G/212GX indicators are equipped with annunciators that are turned on to show that the display is in the mode corresponding to the annunciator label or that the status shown by the label is active. This section describes each annunciator. Refer to Figure No. 16 for the location of the annunciators on the 212G and Figure No. 17 for the location of the annunciators on the 212GX.

212G Annunciators

LB	This will show on the right of the display to indicate that the displayed weight unit is pounds.
KG	This will show on the right of the display to indicate that the displayed unit of weight measurement is kilograms.
N	This will show on the right of the display to indicate the current displayed weight is Net weight (Gross weight less Tare weight).
G	This will show on the right of the display to indicate the current displayed weight is Gross weight. Note that Gross weight will be displayed when no tare weight is stored.
T	This will show on the right of the display to indicate the current displayed weight is the Tare weight.
CNT	This will show on the right of the display to indicate that the value displayed is a count quantity and not weight.
UNLOAD	This will show on the right of the display to indicate the scale is in UNLOAD mode.
*	This is the Low Battery annunciator. It is used to signal that the battery does not have a sufficient charge.
→0←	This is the ZERO annunciator. It is turned on to indicate that the weight displayed is within $\pm 1/4$ division of true zero.
▲▲	This is the STABLE weight annunciator. It is turned on when the weight display is stable. When off, it means that the change in successive weight samples is greater than the motion limits selected during setup.
UNDER	This annunciator is used to signal that the displayed weight is less than the minimum value of acceptable weight used in the Checkweigher feature. Note that this annunciator is active only when the Checkweigher feature is enabled.
ACCEPT	This annunciator is used to signal that the displayed weight is within the acceptable weight limits for the Checkweigher feature. That is, it is equal to or greater than the minimum acceptable weight and equal to or less than the maximum acceptable weight. Note that this annunciator is active only when the Checkweigher feature has been enabled.
OVER	This annunciator is used to signal that the displayed weight is equal to or greater than the minimum value of over weight used in the Checkweigher feature. Note that this annunciator is active only when the Checkweigher feature has been enabled.

ID	The ID annunciator is turned on to indicate that the value displayed is the identification number currently in use.
MEM	The MEM annunciator is used by the ID Storage feature and is turned on to show that the indicator is performing an ID storage function. It is used in conjunction with the ID annunciator to indicate when a permanent ID number is to be entered.
ACCUM	The ACCUM annunciator is turned on to indicate that the value displayed is the contents of the accumulator associated with the currently selected ID number.
1, 2, 3, 4, 5, 6, 7, 8	These numeric annunciators are turned on to signal that the corresponding PWC output is active.
<i>LO BAT</i>	IMPORTANT! When the battery voltage drops to a level where operation is affected, the indicator will display this message and automatically turn OFF.

212GX Annunciators

- 0←** This is the ZERO annunciator. It is turned on to indicate that the weight displayed is within $\pm 1/4$ division of true zero.
- ▲▲** This is the STABLE weight annunciator. It is turned on when the weight display is stable. When off, it means that the change in successive weight samples is greater than the motion limits selected during setup.
- HOLD** This annunciator is turned on to indicate the current displayed weight is held (using either the **HOLD** key or the Auto-Hold feature).
- NET** This annunciator is turned on to indicate that the current displayed weight is Net weight (Gross weight less Tare weight).
- GROSS** This annunciator is turned on to indicate that the current displayed weight is Gross weight.
Note that Gross weight will be displayed when no tare weight is stored.
- TARE** This annunciator is turned on to indicate that the current displayed weight is the Tare weight.
- lb** This annunciator is located to the right of the weight display and is turned on to show that the displayed weight unit is pounds.
- kg** This annunciator is located to the right of the weight display and is used to indicate that the displayed unit of weight measurement is kilograms.
- Lo Bat** This annunciator is turned on to indicate the battery does not have a sufficient charge.
- UNDER
1** This annunciator is used to signal that the displayed weight is less than the minimum value of acceptable weight used in the Checkweigher feature. Note that this annunciator is active only when the Checkweigher feature is enabled.
The PWC1 annunciator is turned on to indicate that the displayed weight is equal to or greater than the weight value stored as preset number 1. Note that this annunciator is active only when the Preset Weight Comparator feature has been enabled.
- ACCEPT
2** This annunciator is used to signal that the displayed weight is within the acceptable weight limits for the Checkweigher feature. That is, it is equal to or greater than the minimum acceptable weight and equal to or less than the maximum acceptable weight. Note that this annunciator is active only when the Checkweigher feature has been enabled.
The PWC2 annunciator is turned on to indicate that the displayed weight is equal to or greater than the weight value stored as preset number 2. Note that this annunciator is active only when the Preset Weight Comparator feature has been enabled.

OVER
3

This annunciator is used to signal that the displayed weight is equal to or greater than the minimum value of over weight used in the Checkweigher feature. Note that this annunciator is active only when the Checkweigher feature has been enabled.

The PWC3 annunciator is turned on to indicate that the displayed weight is equal to or greater than the weight value stored as preset number 3. Note that this annunciator is active only when the Preset Weight Comparator feature has been enabled.

NOTE: PWC's 4 thru 8 do not have display annunciators.

ACCUM

The ACCUM annunciator is turned on to indicate that the value displayed is the contents of the accumulator associated with the currently selected ID number.

PCS

This annunciator is turned on to indicate that the current value displayed is a count quantity and not weight.

LO BAT

IMPORTANT! When the battery voltage drops to a level where operation is affected, the indicator will display this message and automatically turn OFF.

SETUP AND CALIBRATION

Your Model 212G/212GX indicator has been thoroughly tested and calibrated before being shipped to you. If you received the indicators attached to a scale, calibration is not necessary. If the indicator is being connected to a scale for the first time or recalibration is necessary for other reasons, proceed as indicated.

The calibration switch is located on a bracket on the inside of the enclosure front panel. You may gain access to this switch simply by removing the 12 access screws on the front panel. Refer to Figure No. 18.

Calibration Switch

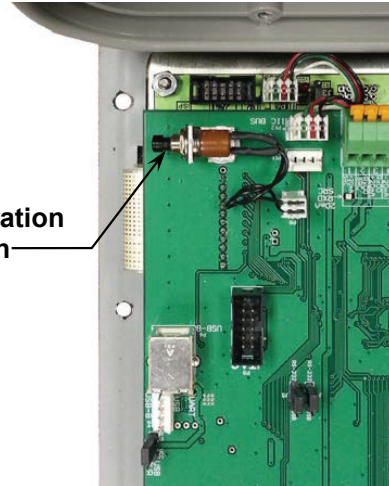

Figure No. 18



DO NOT operate the keypad with pointed objects (pencils, pens, etc).
Damage to keypad resulting from this practice is **NOT** covered under warranty.

Enter Setup Mode

1. Make sure the indicator is turned OFF.
2. Remove the 12 screws securing the front panel.
3. Press the **ON/OFF** key to turn the indicator ON.
4. Press and release the calibration switch. Refer to Figure No. 18 for the location of the calibration switch.
5. The *SETUP* menu prompt will be displayed.
6. Continue to press and release the switch to rotate through the beginning point for entering the setup mode.

Setup Menus

<i>SETUP</i>	Setup Mode (starts at <i>USA</i> prompt)
<i>A-D</i>	Analog to Digital Filtering (starts at <i>DFLT=</i> prompt)
<i>CAL</i>	Calibration (starts at <i>CAL1</i> prompt)
<i>SST</i>	Setup Guardian Scale (starts at <i>TLOW</i> prompt)
<i>OPER</i>	Mode of Operation (starts at <i>OPER=</i> prompt)
<i>SIO</i>	Serial Input/Output (starts at <i>SIO D²</i> prompt)
<i>PRINT</i>	Print Tab Settings (starts at <i>PORT</i> prompt)
<i>F SPAN</i>	Fine Span Adjustment
<i>HI RES</i>	Display high-resolution weight mode
<i>LOCOUT</i>	Key lock out function
<i>OPTION</i>	Option Card Configuration (only displayed when option card is installed)

If you press the **ENTER** key at the *SETUP* prompt, you may proceed through to the next section (up to and including *F SPAN*) by pressing the **ENTER** key.

If you press the **ZERO** key, *DFLTSP* is displayed. This allows all setup parameter values to be replaced with predetermined defaults.



IMPORTANT! Setup may be interrupted at any time. **ALL** data previously entered and finalized with the **ENTER** key will be retained in the non-volatile memory.

Pressing the calibration switch *at any prompt* will return you to the *SETUP* menu. To exit setup, press the * key with any of the above menu selections displayed or cycle power at any time (press the **ON/OFF** key twice).

NOTE: With the exception of the *SETUP* prompt, the prompts displayed for each section are different if you push the calibration switch instead of pressing the **ENTER** key to proceed through the section. *For example*, if you press the calibration switch with the *SETUP* displayed, the next prompt displayed will be *R-D*. If you step through the setup prompts by pressing the **ENTER** key, the next prompt displayed will be *R-D?*. In addition, at a prompt with the *?* displayed, you must press the **ENTER** key, the **1/YES** key then the **ENTER** key again to proceed with that section. To skip the section and advance to the next menu selection, press the **ENTER** key twice.

SETUP

USA= (Domestic or International)

With *SETUP* displayed, press the **ENTER** key. The display will change to *USA=*. Press the **ENTER** key to show the current value. If the setting displayed is acceptable, press the **ENTER** key again to save it. Otherwise, using the numeric keys, **0/NO** or **1/YES**, enter the new setting, then press the **ENTER** key to save it.

USA=1 (Domestic)

DATE = mm/dd/yy

TRL = no

CRP + 4% to OC

USA=0 (International)

DATE = dd/mm/yy

TRL = yes

CRP + 9 grads to OC

PT printed with tare

Lamp test on power up

If you selected *USA = 0* (International), an additional prompt, *PASS=* will be displayed.

If you selected *USA = 1* (Domestic) proceed to *LFT=* (Legal For Trade).

PASS (Password Y/N)

The *PASS* (Password Y/N) prompt determines whether a password is required to enter Setup and Calibration on indicators programmed for international use. Note that this prompt is only displayed when *USA = 0* (International) is selected.

With the display showing *PASS*, press the **ENTER** key to show the current value. If the setting displayed is acceptable, press the **ENTER** key again to save it. Otherwise, using the numeric keys, **0/NO** or **1/YES**, enter the new setting, then press the **ENTER** key to save it.

PASS (No)

Password protection is not needed.

Setup advances to the *LFT=* prompt

PASS (Yes)

Password protection is desired. The next prompt will be *PASS=*

Press the **ENTER** key to see the current password value. If the password displayed is acceptable, press the **ENTER** key again to save it. Otherwise, using the numeric keys enter the new password (up to 6 digits) and then press the **ENTER** key to save it.

Password Operation

With the *PASS* prompt enabled (set to YES), anytime the operator tries to enter *SETUP*, the display will show the *PASS=* prompt requiring the operator to enter the correct password. If the wrong password is entered the indicator displays *ERROR* momentarily and returns to the weight mode. Note that the password is not displayed when the operator is entering it.

It is recommended to write the password down and store it in a secure location. If the password is forgotten or lost and a change to the indicator setup is required, the indicator must be reprogrammed. **WARNING!** Reprogramming the indicator will erase **all** the contents of the Nov-Ram and memory.

LFT= (Legal For Trade)

Press the **ENTER** key to show the current value. If the setting displayed is acceptable, press the **ENTER** key again to save it. Otherwise, using the numeric keys, **0/NO** or **1/YES**, enter the new setting, then press the **ENTER** key to save it.

LFT=1

Interval Settings (*INT=*) allowed
are: 1, 2, 5, 10, 20, 50

LFT=0

Interval Setting (*INT=*) is
selectable from 1 to 99.

NOTE: When both *LFT=1* and *USA=1*, the followings results occur:

Scale must have between 100 and 10,000 divisions
TRA = .5 or 0 to 3
Inhibit serial data during input
Disables counting function in Normal Scale mode of operation (*OPER=0*)
DATE = mm/dd/yy
TRL = no
CAP + 4% to OC
Display will show "Accumd" momentarily whenever the Gross or Net
accumulator is updated

NOTE: When *LFT=1* and *USA=0*, the followings results occur:

UNS = 1
DATE = dd/mm/yy
TRL = yes
CAP + 9 grads to OC
PT printed with tare
Lamp test on power up
Display will show "Accumd" momentarily whenever the Gross or Net
accumulator is updated

UNIT= (Weighing Unit 1)

Press the **ENTER** key to show the current value. If the setting displayed is acceptable, press the **ENTER** key again to save it. Otherwise, using the numeric keys enter the new setting and then press the **ENTER** key to save it. Allowable values are:

For the 212G

0 = none	4 = oz (ounces)
1 = tn (tons)	5 = kg (kilograms)
2 = g (grams)	6 = tonnes (metric tons)
3 = lb (pounds)	

For the 212GX

0 = none	
3 = lb (pounds)	5 = kg (kilograms)

INT= (Interval Setting)

Press the **ENTER** key to show the current value.

If *LFT = 1* (Legal For Trade = YES), using the numeric keys enter the new setting, then press the **ENTER** key to save it. Allowable values are: 1, 2, 5, 10, 20 or 50.

If *LFT=0* (Legal For Trade = NO), using the numeric keys enter the new setting, then press the **ENTER** key to save it. Allowable values are: 1 through 99.

In either case, if the setting displayed is acceptable, press the **ENTER** key again it.

DPP= (Decimal Point Setting)

Press the **ENTER** key to show the current value. If the setting displayed is acceptable, press the **ENTER** key again to save it. Otherwise, using the numeric keys enter the new setting and then press the **ENTER** key to save it. Allowable values are: 0, 1, 2 or 3.

0 = X X X X X X
1 = X X X X X . X

2 = X X X X . X X
3 = X X X . X X X

CAP= (Capacity)

Press the **ENTER** key to show the current value. If the setting displayed is acceptable, press the **ENTER** key again to save it. Otherwise, using the numeric keys enter the new setting and then press the **ENTER** key to save it. Allowable values are: 1 through 999,999.

NOTE: Capacity cannot exceed 999,999.

UNIT2= (Weighing Unit 2)

Press the **ENTER** key to show the current value. If the setting displayed is acceptable, press the **ENTER** key again to save it. Otherwise, using the numeric keys enter the new setting and then press the **ENTER** key to save it. Allowable values are:

For the 212G

0 = none
1 = tn (tons)
2 = g (grams)
3 = lb (pounds)

4 = oz (ounces)
5 = kg (kilograms)
6 = tonnes (metric tons)

For the 212GX

0 = none
3 = lb (pounds)

5 = kg (kilograms)



NOTE: The selection for *UNIT2* can not be the same as *UNIT1*. In addition, dependent upon the selection for *UNIT1* and the interval and decimal point settings, not all unit combinations are available.

TRA= (Zero Tracking Range)

Press the **ENTER** key to show the current value. If the setting displayed is acceptable, press the **ENTER** key again to save it. Otherwise, using the numeric keys enter the new setting and then press the **ENTER** key to save it. Allowable values are: 0 (disables Zero Tracking), .5, or 1 through 9.

TRL= (4% Zero Range)

Press the **ENTER** key to show the current value. If the setting displayed is acceptable, press the **ENTER** key again to save it. Otherwise, using the numeric keys, **0/NO** or **1/YES**, enter the new setting and then press the **ENTER** key to save it.

TRL=YES
4% of scale capacity

TRL=NO
Full capacity (no limit)

PUD= (Power-Up Zero Feature)

Press the **ENTER** key to show the current value. If the setting displayed is acceptable, press the **ENTER** key again to save it. Otherwise, using the numeric keys, **0/NO** or **1/YES**, enter the new setting and then press the **ENTER** key to save it.

PUD=YES
Automatic Re-Zero on Power-Up

PUD=NO
No Re-Zero on Power-Up

TD= (12 or 24 Time Format)

Press the **ENTER** key to show the current value. If the setting displayed is acceptable, press the **ENTER** key again to save it. Otherwise, use the numeric keys to select the format (12 or 24 hour) clock operation and then press the **ENTER** key to save it. Note that in the 24 hour format, 12 is added to all times after noon, i.e. 3 PM would be 1500.

TD=12

12 hour clock (3PM displays 3:00)

TD=24

24 hour clock (3PM displays 15:00)

SLEEP= (Sleep Mode Feature)

The Sleep Mode feature conserves battery power when the indicator remain unused for a selected period of time. With the feature enabled, the load cell excitation will be reduced and the display will be blank.

Press the **ENTER** key to show the current status of this feature. If a number other than 0 is shown, this feature is selected and the number shown corresponds to the number of minutes of a stable zero weight reading before the indicator enter the sleep mode. If the setting displayed is acceptable, press the **ENTER** key again to save it. Otherwise, use the numeric keys to enter a new value (0 to 10) and then press the **ENTER** key to store the new setting. Note that entry of a 0 disables this feature.

A OFF= (Auto Shutoff)

The Automatic Shutoff feature will automatically turn the indicator off (when it is not in use) after a predetermined period of inactivity to prolong battery life. To turn the instrument back on you must press the **ON/OFF** key.

Press the **ENTER** key to show the current status for this feature. A number other than 0 indicates that the auto shutoff feature is enabled and the displayed number corresponds to the number of minutes of stable weight displayed before the indicator is turned off automatically. Note that a 0 indicates the feature has been turned off. If the setting displayed is acceptable, press the **ENTER** key again to save it. Otherwise, use the numeric keys to enter a new value (0 to 10) and then press the **ENTER** key to store the new setting.

CLTAR= (Clear Tare)

The Clear Tare feature allows the indicator to clear the Stored Tare weight when the Net weight goes below a value greater than 1/2 the stored tare weight or goes below zero (a negative net weight after display of a positive net weight). With this feature enabled, the operator must re-set the tare after completion of a transaction when the load (container plus item) is removed from the scale.

Press the **ENTER** key to show the current value. If the setting displayed is acceptable, press the **ENTER** key again to save it. Otherwise, using the numeric keys, **0/NO** or **1/YES**, enter the new setting, then press the **ENTER** key to save it.

CLTAR=1 (Yes)

Automatically clears Stored Tare when Net weight goes below zero

CLTAR=0 (No)

Stored Tare is not cleared when Net weight goes below zero

R - D (R - DP) – Analog to Digital Filtering

SER5CL - (REMOTE INDICATOR SETUP)

If the indicator is to function as a remote indicator, press the **YES** key at the *SER5CL* prompt. If not then press the **NO** key at the prompt.



IMPORTANT! If a 200, 205, 210 or 215 indicator is to be used as the LOCAL and as the REMOTE, then both indicators **MUST** have Rev 2.6.3 or greater software installed.

If a combination of 200, 205, 210 or 215 and a 225 indicator are to be used in a LOCAL/REMOTE configuration, then the remote 200, 205, 210 or 215 indicator **MUST** have Rev 2.6.1 or greater software installed, and the 225 indicator **MUST** have Rev 1.0.K or greater software installed.

LRP= (Local/Remote Port)

NOTE: This will only be displayed if *SER5CL* was set to **YES**

Press the **ENTER** key to show the current value. If the setting displayed is acceptable, press the **ENTER** key again to save it. Otherwise, using the numeric keys enter the new setting and then press the **ENTER** key to save it. Allowable values are: 0, 1, 2 or 3 (for port 0 through port 3) and 4 for the optional 2xx-RS232 card (if installed).

DFLT= (Digital Filtering)

With *R - D (R - DP)* displayed, press the **ENTER** key. The display will change to *DFLT=*. Press the **ENTER** key to show the current value. If the setting displayed is acceptable, press the **ENTER** key to save it. Otherwise, using the numeric keys enter the new setting, then press the **ENTER** key to save it. Allowable values are: 0, 1, 2 or 3. Note, that if you select 3 (Custom Filtering) two additional prompts will be displayed.

<i>DFLT=</i>	
0	Disabled – NO Filtering
1	MINIMAL FILTERING (sample rate = 2)
2	MODERATE FILTERING (sample rate = 1)
3	CUSTOM FILTERING

NOTE: The prompts, *F=* (Filter Level), *H=* (High Frequency Filter Value) and *B=* (Break Range) will only be displayed if you selected 3 (Custom Filtering) for the *DFLT=* (Digital Filtering) prompt.

F= (Filter Level)

Press the **ENTER** key to show the current setting for the filter level. The filter level is a number from 0 to 99 that corresponds to the level of filtering with 99 being the greatest filtering and 1 the least. To accept the value displayed, press the **ENTER** key, otherwise, use the numeric keys to enter a new value then press the **ENTER** key to save it. Note that entry of a 0 disables this feature.

B= (Break Range)

Press the **ENTER** key to show the current setting for the break range. The break range is a number from 1 to 255 that corresponds to the number of division change to break out of the filtering. Press the **ENTER** key to keep the displayed value or use the numeric keys to enter a new value and press the **ENTER** key to save the new setting. Note that entry of a 0 disables this feature.

H= (High Frequency Filter Value)

Press the **ENTER** key to show the current setting for the high frequency filter level. The filter level is a number from 0 to 99 that corresponds to the level of filtering with 99 being the greatest filtering and 1 the least. To accept the value displayed, press the **ENTER** key, otherwise, use the numeric keys to enter a new value then press the **ENTER** key to save it. Note that entry of a 0 disables this feature.

SR= (Sample Rate)

Press the **ENTER** key to show the current setting for the sample rate. The value displayed is the sample rate in samples per second. Press the **ENTER** key to save the displayed value or use the numeric keys to enter a new value (1 to 100) and press the **ENTER** key to save it.

UNS= (Motion Range)

Press the **ENTER** key to view the current setting for the range of motion detection. If the displayed value is acceptable, press the **ENTER** key to save it. Otherwise, use the numeric keys to enter the new range (the number of divisions of change permitted before indicating unstable), then press the **ENTER** key to save the new setting. Allowable range values are: 0 through 99 divisions.

SC= (Stable Count)

Press the **ENTER** key to view the current setting for the number of consecutive stable weight readings before indicating stable weight. This helps filter weight readings for stability for use with Auto Print on Balance, or anything trying to capture stable weight. If the displayed value is acceptable, press the **ENTER** key to save it. Otherwise, use the numeric keys to enter a new value and press the **ENTER** key to save the new setting. Allowable values for the stable count are: 3 through 255.

FILTER SETTING RECOMMENDATIONS

Non Critical Sample Rate

If the sample rate is not critical, as in static weighing, set $DFLT=$ to "0" (no filtering), $DFLT=$ "1" ($F=6$, $B=12$, $SR= 2/Sec$), or $DFLT=$ "2" ($F=6$, $B=8$, $SR= 1/Sec$).

Critical Sample Rate

If the sample rate is critical, as in a filling operation, use the Custom Filtering (set $DFLT=$ to "3").

1. $SR=$ SAMPLE RATE (1 to 100 samples/second) determination:

Set the sample rate as close as possible to produce a display graduation change for every graduation of material added to the scale.

$$\frac{\text{Material Flow Rate (lbs/second)}}{\text{Resolution}} =$$

$$\text{EXAMPLE: } \frac{100\text{lbs/sec}}{10\text{lbs}} = 10\text{s/s} = SR$$

2. $B=$ BREAK RANGE (1 to 255 graduations) determination:

Turn the filtering off by setting the $DFLT=$ setting to "0". Operate the system as it will be normally used and, by observation, determine the number of grads of instability that needs to be filtered out. Set the break range ($B=$) to that value.

$$\frac{\text{Weight Change}}{\text{Graduation Value}} = B$$

EXAMPLE: 20,000 x 10lb capacity scale with 800lb variation in the weight display.

$$\frac{800}{10} = B = 80$$

3. $F=$ FILTER SETTING (1 to 99) determination: Set to desired results.

4. If stability is unacceptable with any setting of $F=$, reduce the sample rate and/or increase the break range, $B=$ setting for increased filtering.

CAL (CALP) - Calibration

With **CAL (CALP)** displayed, press the **ENTER** key. The display will change to show the current setting **NO**. If calibration is desired, press the **1/YES** key, then press the **ENTER** key to continue to the **CAL1=** setting, otherwise press the **ENTER** key to advance to the **SID** menu.

CALIBRATION MODES

The 212G/212GX has five modes that can be used to perform calibration. Three of the modes require a test load or test weights, one requires the scale to be empty (and at zero) and the last uses the calibration “C” numbers from a previous calibration. The modes are as follows:

1. Dual-Point with Zero (First Zero)

This is a standard calibration method requiring one weight, an empty scale and has one conversion factor. This method uses two calibration points (**CAL1=** and **CAL2=**) to establish a zero (no load) calibration value and to span the indicator. The two points correspond to zero weight and the test load or test weight and can be applied in any order. This method should be used for first-time calibration and complete recalibration.

2. Dual-Point without Zero (False Zero)

This calibration method requires one test weight and establishes a new conversion factor only. It is used to establish a false (temporary zero) zero without affecting the zero calibration value stored during the last calibration. This is particularly useful in tank weighing applications, where it may be impractical or impossible to completely empty the tank. This method uses two calibration points, **CAL1=** and **CAL2=**. The value of the test weight is entered when **CAL1=** is displayed and the **NET/GROSS** key is pressed when **CAL2=** is displayed.

3. Single-Point for Span Only (Last Zero)

This calibration method requires one test weight and establishes a new conversion factor (span) without affecting the zero calibration value stored during the last calibration. This minimizes placing and removing test weights and is especially useful when checking high capacity scales. This method uses two calibration points, **CAL1=** and **CAL2=**. The value of the test weight is entered when **CAL1=** is displayed and the **ZERO** key is pressed when **CAL2=** is displayed.

4. Single-Point for Zero Only (Only Zero)

This calibration method requires no test weight, an empty scale and establishes a new zero without affecting the conversion factor (span). This is useful to regain the full range of zero limit when the dead load of the scale has changed. This would occur for example, if a guard rail has been added to the scale platform. This method uses two calibration points, **CAL1=** and **CAL2=**. The **ENTER** key is pressed when **CAL1=** is displayed and the **ZERO** key is pressed when **CAL2=** is displayed.

5. Calibration “C” Numbers

The calibration “C” numbers (**C1**, **C2**, **C3** and **C4**) are displayed only during the Test mode operation and are shown at the end of the test. Each number is displayed for approximately 4 seconds, allowing you to record them. These numbers correspond to the calibration setting of the indicator. The numbers may be up to three digits in length. By recording these numbers you will be able to return the indicator to its present calibration settings without using test weights simply by entering the “C” numbers. *Refer to the Calibration “C” Number section of this manual for instructions on viewing the “C” numbers.*

Dual-Point with Zero (First Zero) Calibration

CAL1= – First Calibration Weight

The display will show **CAL1=0**. This is the first of two calibration weights. This weight could be ZERO (NO LOAD) or the TEST WEIGHTS / TEST LOAD.

- If the first calibration weight is to be ZERO (NO LOAD), press the **ENTER** key.
- If the first calibration weight is to be the TEST WEIGHTS / TEST LOAD, use the numeric keys to input the value of the calibrated test weights. **NOTE:** When entering values for **CAL1=**, the digits start displaying on the right side of the display and proceed to the left. When large values are used (more than 3 digits), the **CAL1=** prompt will automatically scroll off the left side of the display to show the additional digits on the right as they are entered.
- Place the weights on the scale platform, then press the **ENTER** key.
- Starting at the left and advancing right, a series of dashes will appear on the display. The dashes will stay on the display momentarily, then disappear, after which the display will show: **CAL2=**.

CAL2= - Second Calibration Weight

The display will show **CAL2=0**. This is the second of two calibration weights. This weight could be ZERO (NO LOAD) or the TEST WEIGHTS / TEST LOAD.

- If the second calibration weight is to be ZERO (NO LOAD), press the **ENTER** key.
- If the second calibration weight is to be the TEST WEIGHTS / TEST LOAD, use the numeric keys to input the value of the calibrated test weights. **NOTE:** When entering values for **CAL2=**, the digits start displaying on the right side of the display and proceed to the left. When large values are used (more than 3 digits), the **CAL2=** prompt will automatically scroll off the left side of the display to show the additional digits on the right as they are entered.
- Place the weights on the scale platform, then press the **ENTER** key.
- Starting at the left and advancing right, a series of dashes will appear on the display. The dashes will stay on the display momentarily, then disappear, after which the display will show: **SID?**.

Dual-Point without Zero (False Zero) Calibration

CAL1= – First Calibration Weight

The display will show *CAL1=0*. This is the first of two calibration steps. This weight is the TEST WEIGHTS / TEST LOAD.

- Place the weights on the scale platform.
- Using the numeric keys, input the value of the calibrated test weights / test load, then press the **ENTER** key. **NOTE:** When entering values for *CAL1=*, the digits start displaying on the right side of the display and proceed to the left. When large values are used (more than 3 digits), the *CAL1=* prompt will automatically scroll off the left side of the display to show the additional digits on the right as they are entered.
- Starting at the left and advancing right, a series of dashes will appear on the display. The dashes will stay on the display momentarily, then disappear, after which the display will show: *CAL2=*.

CAL2= - Second Calibration Weight

The display will show *CAL2=0*. This is the second of two calibration steps.

- Remove the weights on the scale platform, then press the **NET/GROSS** key.
- Starting at the left and advancing right, a series of dashes will appear on the display. The dashes will stay on the display momentarily, then disappear, after which the display will show: *SID?*.

Single-Point for Span Only (Last Zero) Calibration

CAL1= – First Calibration Weight

The display will show *CAL1=0*. This is the first of two calibration steps. This weight is the TEST WEIGHTS / TEST LOAD.

- Zero the scale, then place the weights on the scale platform.
- Using the numeric keys, input the value of the calibrated test weights / test load, then press the **ENTER** key. **NOTE:** When entering values for *CAL1=*, the digits start displaying on the right side of the display and proceed to the left. When large values are used (more than 3 digits), the *CAL1=* prompt will automatically scroll off the left side of the display to show the additional digits on the right as they are entered.
- Starting at the left and advancing right, a series of dashes will appear on the display. The dashes will stay on the display momentarily, then disappear, after which the display will show: *CAL2=*.

CAL2= - Second Calibration Weight

The display will show *CAL2=0*. This is the second of two calibration steps.

- Remove the weights on the scale platform, and then press the **ZERO** key.
- The display will advance to *SID?*.

Single-Point for Zero Only (Only Zero) Calibration

CAL1= – First Calibration Weight

The display will show **CAL1=0**. This is the first of two calibration steps.

- Insure the scale is empty.
- Press the **ENTER** key.
- Starting at the left and advancing right, a series of dashes will appear on the display. The dashes will stay on the display momentarily, then disappear, after which the display will show: **CAL2=**.

CAL2= - Second Calibration Weight

The display will show **CAL2=0**. This is the second of two calibration steps.

- Press the **ZERO** key.
- The display will advance to **SIDP**.

Calibration “C” Numbers

1. With **CAL1=** displayed, press the "diamond T" TARE key.
2. At the **C1=** prompt, press the **ENTER** key to show the current value of the **C1** number.
3. If the **C1=** number displayed is acceptable, press the **ENTER** key again to save it.
4. Otherwise, use the numeric keys to enter a new **C1=** number, then press the **ENTER** key.
5. Repeat steps 2 through 4 for **C2=**, **C3=** and **C4=**.



NOTE: If any components have been changed that affect calibration and/or your scale is used in a commercial application and must be "Legal for Trade" you cannot use the "C" numbers to re-calibrate.

557? Setup Guardian Scale

If a **GUARDIAN** scale is connected to the indicator, at the **557?** prompt press the **YES** key.

The **TLO=** prompt will be displayed. This is the low end of the range of weight that requires adjusting. For example, if after performing linearization testing, the displayed weight is 5 lbs low between 10,000 lbs and 15,000 lbs, the value for the tweak low weight is 10000.

Input the tweak low weight value and then press the **ENTER** key.

The **THI=** prompt will be displayed. This is the high end of the range of weight that requires adjusting. Using the example above, the value for the tweak high weight is 15000.

Input the tweak high weight value and then press the **ENTER** key.

The **TURL=** prompt will be displayed. This is the amount of weight that needs to be added (or subtracted) from the range of weight to bring the displayed weight into tolerance. Again, using the example above, the Tweak Weight value would be 5.

Input the tweak weight value (pressing the **NET** key will change the sign) and then press the **ENTER** key to save it and advance to the **OPER?** menu.

OPER? (Mode of Operation)

With **OPER?** displayed, press the **ENTER** key. The display will change to show the current setting **0**. If Mode of Operation is desired, press the **1/YES** key and then press the **ENTER** key to continue to the **OPER=** prompt. Otherwise press the **ENTER** key to advance to the **5** menu.

Use the numeric keys to select the new mode of operation.

OPER =	0	Normal Scale
	1	ID Storage
	2	Digital Fill Control
	3	Preset Weight Comparator
	4	Check Weigher
	5	Axle Weigher
	6	Livestock Weigher

OPER = 0 (Normal Scale)

ID= (ID Prompt)

The **ID=** (ID=) prompt enables an ID prompt before printing a ticket.

With the display showing **ID=**, press the **ENTER** key to show the current value. If the setting displayed is acceptable, press the **ENTER** key again to save it. Otherwise, using the numeric keys, **0/NO** or **1/YES**, enter the new setting, then press the **ENTER** key to save it.

ID=1 (Yes)

ID= will be displayed when **PRINT** key is pressed and printed on the ticket.

ID=0 (No)

Normal print operation (no ID prompt) will occur.

If you selected **ID=1** (Yes, ID Prompt), an additional prompt, **ACL=** will be displayed.

If you selected **ID=0** (No ID Prompt) proceed to **A-D** (**A-D?**) Analog to Digital Filtering.

A CLR= (Auto Clear ID)

The *A CLR=* (Auto Clear ID) prompt determines whether the ID is automatically cleared after printing the ticket. Note that it is only displayed when *ID= YES* is selected.

With the display showing *A CLR=*, press the **ENTER** key to show the current value. If the setting displayed is acceptable, press the **ENTER** key again to save it. Otherwise, using the numeric keys, **0/NO** or **1/YES**, enter the new setting, then press the **ENTER** key to save it.

A CLR=1 (Yes)

Automatically clears the ID after the ticket has printed.

A CLR=0 (No)

ID is not cleared when ticket prints and can be used for next transaction.

OPER = 1 (ID Storage)

ALARM= (Weight Alarm)

The Weight Alarm will energize PWC1 for a selected time when the weight exceeds a threshold weight.

If the setting displayed is acceptable, press the **ENTER** key to save it. Otherwise, using the numeric keys, **0/NO** or **1/YES**, enter the new setting, then press the **ENTER** key to save it.

H OUT= (High State Before Cutoff)

If the comparator outputs are to be High before cutoff, answer **YES** to this prompt.

OPER = 2 (Digital Fill Control)

SPEED=X (Single or Two Speed Filling)

X=1 Single speed filling

X=2 Two speed filling

G SEQ=X (Gate Sequence for Two Speed Filling)

X=1 AB->B

When filling begins both the "A" (fast) and "B" (slow) outputs will be on until the weight reaches the FAST weight value. The "A" output is turned off and the "B" output remains on until the SLOW weight value is reached.

X=2 A->B

When filling begins the "A" (fast) output will be on until the weight reaches the FAST weight value. The "A" output is turned off and the "B" output is turned on. The "B" output remains on until the SLOW weight value is reached.

X=3 CHATTER-GATE

When filling begins the "A" (fast) output will be turned on, when the FAST weight value is reached the "A" output will pulse on/off until the SLOW weight is reached.

ATRIM= (Auto Trim Weight Compensation)

YES After the target weight minus the trim weight is reached and the scale stabilizes, the trim weight will be automatically adjusted. The adjustment is based on the difference between the target weight and the actual weight filled.

NO No trim weight adjustment will be made at the completion of a filling operation.

APRNT= (Automatic Print)

YES The time, date, and weight will be automatically printed at the conclusion of the fill.

NO No automatic print at the conclusion of the fill.

OPER = 2 (Digital Fill Control), Cont.

DGATE= (Dump Gate Enable)

YES The dump gate is enabled.

NO The dump gate is disabled.

ADISC= (Auto Discharge – If Dump Gate Enabled)

YES At the conclusion of a fill, the hopper will automatically be discharged.

NO No automatic discharge of the hopper at the conclusion of the fill. However, pressing the remote discharge pushbutton or pressing the * and F keys will cause the hopper discharge gate to open.

ATARE= (Automatic Tare)

YES When the filling operation starts the Gross weight will automatically be stored as the Tare weight the display will switch to the Net weight display mode and the filling will continue until the Net target weight is reached.

NO No automatic Tare operation.

STOR?= (Enable storage)

YES

*** and F**

At the ID= prompt, enter the ID. If the ID exists in memory, then the Fill/Fast, Slow and Trim weight values will be retrieved.

*** and PRESET**

At the ID= prompt, enter the ID. The Fill/Fast, Slow, and Trim weight values will be displayed and can be changed, these settings will be stored under the entered ID for later recall.

NO

No ID printing, or storage of filling parameters is allowed.

YES Filling parameters may be stored and recalled by entering an ID

NO No Fill control storage.

H OUT= (High State Before Cutoff)

If the comparator outputs are to be High before cutoff, answer **YES** to this prompt.

OPER = 3 (Preset Weight Comparator)

P OUT= (Number of comparators)

The number of weight comparators can be from 1 to 8.

H OUT= (High state before cutoff)

If the comparator outputs are to be High before cutoff, answer **YES** to this prompt.

P-BAL= (Print-On-Balance)

With only one Preset selected (*P OUT=1*), an additional prompt *P-BAL=* (automatic Print on Balance) will be displayed. If selected (*P-BAL=YES*), when the weight is above or equals the preset value and all motion stops, weight will be printed (if a printer is attached). Note that the weight must go below 50% of the preset value before another print operation can be performed.

If the setting displayed is acceptable, press the **ENTER** key to save it. Otherwise, using the numeric keys, **0/NO** or **1/YES**, enter the new setting, then press the **ENTER** key to save it.

P-BAL=1 (Yes)

Automatic Print on Balance Enabled

P-BAL= 0 (No)

Automatic Print on Balance Disabled

ID= (ID Prompt)

The *ID=* (*ID=*) prompt enables an ID prompt before printing a ticket.

With the display showing *ID=*, press the **ENTER** key to show the current value. If the setting displayed is acceptable, press the **ENTER** key again to save it. Otherwise, using the numeric keys, **0/NO** or **1/YES**, enter the new setting, then press the **ENTER** key to save it.

ID=1 (Yes)

ID= will be displayed when **PRINT** key is pressed and printed on the ticket.

ID=0 (No)

Normal print operation (no ID prompt) will occur.

If you selected *ID=1* (Yes, ID Prompt), an additional prompt, *R CLR=* will be displayed.

If you selected *ID=0* (No ID Prompt) proceed to *R-D* (*R-D?*) Analog to Digital Filtering.

R CLR= (Auto Clear ID)

The *R CLR=* (Auto Clear ID) prompt determines whether the ID is automatically cleared after printing the ticket. Note that it is only displayed when *ID= YES* is selected.

With the display showing *R CLR=*, press the **ENTER** key to show the current value. If the setting displayed is acceptable, press the **ENTER** key again to save it. Otherwise, using the numeric keys, **0/NO** or **1/YES**, enter the new setting, then press the **ENTER** key to save it.

R CLR=1 (Yes)

Automatically clears the ID after the ticket has printed.

R CLR=0 (No)

ID is not cleared when ticket prints and can be used for next transaction.

OPER = 4 (Check Weigher)

H OUT= (High State Before Cutoff)

If the comparator outputs are to be High before cutoff, answer **YES** to this prompt.

P-BAL= (Print-On-Accept)

With Checkweigher selected, an additional prompt *P BAL*, Print on Balance, (automatic print on accept) will be displayed. If selected (*P-BAL=YES*), when the scale weight is stable and in the accept range of the checkweigher, the weight will be printed (if a printer is attached).

If the setting displayed is acceptable, press the **ENTER** key to save it. Otherwise, using the numeric keys, **0/NO** or **1/YES**, enter the new setting, then press the **ENTER** key to save it.

P-BAL=1 (Yes)

Automatic Print on Accept Enabled

P-BAL=0 (No)

Automatic Print on Accept Disabled

ID= (ID Prompt)

The *ID=* (*ID=*) prompt enables an ID prompt before printing a ticket.

With the display showing *ID=*, press the **ENTER** key to show the current value. If the setting displayed is acceptable, press the **ENTER** key again to save it. Otherwise, using the numeric keys, **0/NO** or **1/YES**, enter the new setting, then press the **ENTER** key to save it.

ID=1 (Yes)

ID= will be displayed when **PRINT** key is pressed and printed on the ticket.

ID=0 (No)

Normal print operation (no ID prompt) will occur.

If you selected *ID=1* (Yes, ID Prompt), an additional prompt, *A CLR=* will be displayed.

If you selected *ID=0* (No ID Prompt) proceed to *A-D (A-D?)* Analog to Digital Filtering.

A CLR= (Auto Clear ID)

The *A CLR=* (Auto Clear ID) prompt determines whether the ID is automatically cleared after printing the ticket. Note that it is only displayed when *ID= YES* is selected.

With the display showing *A CLR=*, press the **ENTER** key to show the current value. If the setting displayed is acceptable, press the **ENTER** key again to save it. Otherwise, using the numeric keys, **0/NO** or **1/YES**, enter the new setting, then press the **ENTER** key to save it.

A CLR=1 (Yes)

Automatically clears the ID after the ticket has printed.

A CLR=0 (No)

ID is not cleared when ticket prints and can be used for next transaction.

OPER = 5 (Axle Weigher)

ID= (ID Prompt)

The *ID=* (ID=) prompt enables an ID prompt before printing a ticket.

With the display showing *ID=*, press the **ENTER** key to show the current value. If the setting displayed is acceptable, press the **ENTER** key again to save it. Otherwise, using the numeric keys, **0/NO** or **1/YES**, enter the new setting, then press the **ENTER** key to save it.

ID=1 (Yes)

ID= will be displayed when **PRINT** key is pressed and printed on the ticket.

ID=0 (No)

Normal print operation (no ID prompt) will occur.

If you selected *ID=1* (Yes, ID Prompt), an additional prompt, *A CLR=* will be displayed.

If you selected *ID=0* (No ID Prompt) proceed to *A-D (A-DP)* Analog to Digital Filtering.

A CLR= (Auto Clear ID)

The *A CLR=* (Auto Clear ID) prompt determines whether the ID is automatically cleared after printing the ticket. Note that it is only displayed when *ID= YES* is selected.

With the display showing *A CLR=*, press the **ENTER** key to show the current value. If the setting displayed is acceptable, press the **ENTER** key again to save it. Otherwise, using the numeric keys, **0/NO** or **1/YES**, enter the new setting, then press the **ENTER** key to save it.

A CLR=1 (Yes)

Automatically clears the ID after the ticket has printed.

A CLR=0 (No)

ID is not cleared when ticket prints and can be used for next transaction.

THSHLD= (Threshold Weight)

With Axle Weigher selected, an additional prompt *THSHLD=* (Threshold Weight) will be displayed.

Press the **ENTER** key to show the current value. If the setting displayed is acceptable, press the **ENTER** key again to save it. Otherwise, use the numeric keys to enter a new value for the threshold weight or enter a zero (0) to disable the traffic light and then press the **ENTER** key to save it.

OPER = 6 (Livestock Weigher)

ID= (ID Prompt)

The *ID=* (ID=) prompt enables an ID prompt before printing a ticket.

With the display showing *ID=*, press the **ENTER** key to show the current value. If the setting displayed is acceptable, press the **ENTER** key again to save it. Otherwise, using the numeric keys, **0/NO** or **1/YES**, enter the new setting, then press the **ENTER** key to save it.

ID=1 (Yes)

ID= will be displayed when **PRINT** key is pressed and printed on the ticket.

ID=0 (No)

Normal print operation (no ID prompt) will occur.

If you selected *ID=1* (Yes, ID Prompt), an additional prompt, *A CLR=* will be displayed.

If you selected *ID=0* (No ID Prompt) proceed to *A-D (A-DP)* Analog to Digital Filtering.

A CLR= (Auto Clear ID)

The *A CLR=* (Auto Clear ID) prompt determines whether the ID is automatically cleared after printing the ticket. Note that it is only displayed when *ID= YES* is selected.

With the display showing *A CLR=*, press the **ENTER** key to show the current value. If the setting displayed is acceptable, press the **ENTER** key again to save it. Otherwise, using the numeric keys, **0/NO** or **1/YES**, enter the new setting, then press the **ENTER** key to save it.

A CLR=1 (Yes)

Automatically clears the ID after the ticket has printed.

A CLR=0 (No)

ID is not cleared when ticket prints and can be used for next transaction.

Setup your desired ticket format using the print tabs in the setup menu. Below is the list of selectable print tabs along with a brief print tab description.

- *HOURL=* Prints the current time
- *DATE=* Prints the current date
- *ID=* Prints the keyed ID
- *CNC N=* Prints the consecutive number (ticket number)
- *GROSS=* Prints the stable Gross weight
- *G ACC=* Prints the Gross weight accumulator
- *COUNT=* Prints the keyed animal head count
- *AVERG=* Prints the average animal weight if there's a stored head count
- *CRLF=* Select YES to append a LF to each printed line
- *EOP=* Number of new lines to append at the end of a ticket

SIO (SIO?) - Serial Input/Output

With *SIO (SIO?)* displayed, press the **ENTER** key. The display will change to show the current setting *NO*. To skip configuring the *SIO* (serial input/output) and proceed to the *PRINT?* menu, press the **ENTER** key again. To configure the *SIO*, press the numeric key **1/YES** (display will change to *YES*) and then press the **ENTER** key. After pressing the **ENTER** key, the display will change to *SIO 0*.

SIO 0? (Setup Serial Port 0)

Press the **ENTER** key. The display will change to show the current setting *NO*. To skip configuring the *SIO PORT 0* (serial input/output) and proceed to the *SIO 1?* menu, press the **ENTER** key again. To configure the *SIO 0*, press the numeric key **1/YES** (display will change to *YES*) and then press the **ENTER** key.

BAUD0= (Serial Port 0 Baud Rate)

Press the **ENTER** key to show the current value. If the setting displayed is acceptable, press the **ENTER** key again to save it. Otherwise, use the numeric keys to enter a new baud rate for the serial ports, then press the **ENTER** key to save it. Allowable values are:

12 = 1200 Baud	24 = 2400 Baud	48 = 4800 Baud
96 = 9600 Baud	14 = 14.4k Baud	19 = 19.2k Baud
28 = 28.8k Baud	38 = 38.4k Baud	57 = 57.6k Baud
76 = 76.8k Baud	11 = 115.2k Baud	23 = 230.4k Baud

PRTY0= (Serial Port 0 Parity)

Press the **ENTER** key to show the current value. If the setting displayed is acceptable, press the **ENTER** key again to save it. Otherwise, using the numeric keys enter the new setting, then press the **ENTER** key to save it. Allowable values are: 0, 1, or 2.

0 = NONE (No Parity)	1 = Odd Parity	2 = Even Parity
----------------------	----------------	-----------------

BIT50= (Serial Port 0 Data Bits)

Press the **ENTER** key to show the current value. If the setting displayed is acceptable, press the **ENTER** key again to save it. Otherwise, using the numeric keys enter the new setting, then press the **ENTER** key to save it. Allowable values are: 7 or 8.

STOP0= (Serial Port 0 Stop Bits)

Press the **ENTER** key to show the current value. If the setting displayed is acceptable, press the **ENTER** key again to save it. Otherwise, using the numeric keys enter the new setting, then press the **ENTER** key to save it. Allowable values are: 1 or 2.

CONTO= (Continuous Output Serial Port 0)

Press the **ENTER** key to show the current value. If the setting displayed is acceptable, press the **ENTER** key again to save it. Otherwise, using the numeric keys, **0/NO** or **1/YES**, enter the new setting, then press the **ENTER** key to save it.

CONTO= YES

Continuous Output

CONTO= NO

No Continuous Output

If *CONTO= YES* (Continuous Output) is selected, an additional prompt, *TYPE0=* will be displayed.

If *CONTO= NO* (No Continuous Output) is selected, proceed to the Weight On Demand section.

TYPE0= (Continuous 0 Output Format)

Press the **ENTER** key to show the current value. If the setting displayed is acceptable, press the **ENTER** key again to save it. Otherwise, using the numeric keys enter the new setting, then press the **ENTER** key to save it. Allowable values are:

0 = SMA	1 = SB-400	2 = SB-200
3 = Rice Lake IQ355	4 = AnDFV	5 = WI110
6 = Number Only	7 = Toledo Long/Short	8 = SB500 with Traffic Light
9 = Ranger 5000 Format A		

SMA – (TYPE = 0)

If SMA is selected, the data will be transmitted in the following format:

<lf><s><r><n><m><f><xxxxxx.xxx><uuu><cr>

Where:

lf =	Line Feed	
s =	Flags	Z= center of Zero, O = Overcap, E = zero Error, e = weight not currently being displayed
r =	Range	1, 2, 3, ...
n =	Mode	G = Gross, T = Tare, N = Net
m =	Motion	M = Motion, " "(blank) = no motion
f =	Custom	Custom flag
xxxxxx.xxx =	Weight	Six digits with decimal point
uuu =	Units	tn, lb, l/o, oz, t, kg, g
cr =	Carriage Return	(hex 0D)

SB-400 – (TYPE = 1)

If SB-400* or Computer is selected, the data will be transmitted in the following format:

<s><xxxxxx><d><uu><m><cc><cr>

Where:

s =	Sign	"-" = negative, " "(blank) = positive
xxxxxx.xxx =	Weight	Six digits
d =	Decimal point	Added to string if enabled in setup
uu =	Units	tn, lb, l/o, oz, t, kg, g
m =	Mode	G = Gross, N = Net
cc =	Weight Status	OC = overcap CZ = center of zero MO = motion ee = weight not currently being displayed
cr =	Carriage Return	(hex 0D)

*The SB-80, SB-300 (*multiple displays not supported*) and WinVRS use the SB-400 format.

SB-200 – (TYPE = 2)

If SB-200 is selected, the data will be transmitted in the following format:

<cr><s><xxxxxx><d><c><uu><m> ETX

Where:

cr =	Carriage Return	(hex 0D)
s =	Sign	"-" = negative, " " (<i>blank</i>) = positive
xxxxxx.xxx =	Weight	(with leading zeros)
d =	Decimal point	Embedded into weight (after weight dpp=0)
c =	status	m = motion o = overcap e = weight not currently being displayed
uu =	Units	tn, lb, l/o, oz, t, kg, g
m =	Mode	G = Gross, N = Net
ETX =	End of TeXt	(hex 03) MUST terminate ALL serial commands

Rice Lake IQ355 – (TYPE = 3)

If Rice Lake IQ355 is selected, the data will be transmitted in the following format:

<stx><s>xxxxxxx<u><m><s><cr><lf>

AnDFV – (TYPE = 4)

If AnDFV is selected, the data will be transmitted in the following format:

<hdr1>,xxxxx<uu><cr><lf>

WI110 – (TYPE = 5)

If WI110 is selected, the data will be transmitted in the following format:

<m><sp><s>xxxxx<sp><uu><cr><lf>

Number Only – (TYPE = 6)

If number only is selected, the data will be transmitted in the following format:

xxxxxx<cr><lf>

Toledo Short – (TYPE = 7)

If Toledo Short is selected, the data will be transmitted in the following format:

<stx><swa><swb><swc>xxxxxx<cr><sum>

Toledo Long – (TYPE=7)

If Toledo Long is selected, the data will be transmitted in the following format:

<stx><swa><swb><swc>xxxxxyyyyyy<cr><sum>

Where:

xxxxxx =	Weight	(leading zeros suppressed)
yyyyyy =	Tare Weight	(leading zeros suppressed)

SB500 (with Traffic Light) – (TYPE = 8)

If SB500 (with Traffic Light) is selected, the data will be transmitted in the following format:

`%NDDDDDDDDDT<CR>`

Where:

N = Panel number for a daisy chain configuration

D = Byte of data to display at respective location on the scoreboard

T = Control character for the traffic light. Valid characters for T are:

G = Turn on Green light

R = Turn on Red light

" "(space) = no lights on

<CR> = Carriage Return

Ranger 5000 Format A – (TYPE = 9)

In setup, after selecting type 9 for the Ranger 5000 Format A:

At the *STARTB* prompt, enter the decimal value for the start character.

Valid entry is 0 to 126.

At the *ENDB 1* prompt, enter the decimal value for the first end character.

Valid entry is 0 to 126.

At the *ENDB 2* prompt, enter the decimal value for the second end character.

Valid entry is 0 to 126.

If the above items are '0' then the character will not be included in the data stream.

If Ranger 5000 Format A is selected, the data will be transmitted in the following format:

`<StArtb>Sign WeightA(7) Status`

Where:

Sign = The sign of the weight ('+' for positive, '-' for negative)

WeightA = A seven character string containing the current weight including the decimal point. If there is no decimal point, then the first character is a space. Leading zero blanking applies.

Status = Provides information on the weight reading. The characters G/N/U/O/M/E represent Gross/Net/Underload/Overload/Motion/Error respectively.

Weight On Demand

If continuous output has not been selected for Serial Port 0 (*CONTD=NO*), the 212G/212GX indicator will respond to a weight request (ENQ).

The host device (computer) sends:

ENQ - (hex 05)

The 212G/212GX will respond:

<s><xxxxxx><d><uu><m><cc><cr>

Where:

s =	Sign	"-" = negative, " " (<i>blank</i>) = positive
xxxxxx.xxx =	Weight	Six digits
d =	Decimal point	Added to string if enabled in setup
uu =	Units	tn, lb, l/o, oz, t, kg, g
m =	Mode	G = Gross, N = Net
cc =	Weight Status	OC = overcap CZ = center of zero MO = motion ee = weight not currently being displayed
cr =	Carriage Return	(hex 0D)

SIO 1P (Setup Serial Port 1)

Press the **ENTER** key. The display will change to show the current setting *NO*. To skip configuring the *SIO PORT 1* (serial input/output) and proceed to the *SIO 2P* menu, press the **ENTER** key again. To configure the *SIO 1*, press the numeric key **1/YES** (display will change to *YES*) and then press the **ENTER** key.

BAUD1= (Serial Port 1 Baud Rate)

Press the **ENTER** key to show the current value. If the setting displayed is acceptable, press the **ENTER** key again to save it. Otherwise, use the numeric keys to enter a new baud rate for the serial ports, then press the **ENTER** key to save it. Allowable values are:

12 = 1200 Baud	24 = 2400 Baud	48 = 4800 Baud
96 = 9600 Baud	14 = 14.4k Baud	19 = 19.2k Baud
28 = 28.8k Baud	38 = 38.4k Baud	57 = 57.6k Baud
76 = 76.8k Baud	11 = 115.2k Baud	23 = 230.4k Baud

PRTY1= (Serial Port 1 Parity)

Press the **ENTER** key to show the current value. If the setting displayed is acceptable, press the **ENTER** key again to save it. Otherwise, using the numeric keys enter the new setting, then press the **ENTER** key to save it. Allowable values are: 0, 1, or 2.

0 = NONE (No Parity)	1 = Odd Parity	2 = Even Parity
----------------------	----------------	-----------------

BITS1= (Serial Port 1 Data Bits)

Press the **ENTER** key to show the current value. If the setting displayed is acceptable, press the **ENTER** key again to save it. Otherwise, using the numeric keys enter the new setting, then press the **ENTER** key to save it. Allowable values are: 7 or 8.

STOP1= (Serial Port 1 Stop Bits)

Press the **ENTER** key to show the current value. If the setting displayed is acceptable, press the **ENTER** key again to save it. Otherwise, using the numeric keys enter the new setting, then press the **ENTER** key to save it. Allowable values are: 1 or 2.

CONT1= (Continuous Output Serial Port 1)

Press the **ENTER** key to show the current value. If the setting displayed is acceptable, press the **ENTER** key again to save it. Otherwise, using the numeric keys, **0/NO** or **1/YES**, enter the new setting, then press the **ENTER** key to save it.

<i>CONT1= YES</i> Continuous Output	<i>CONT1= NO</i> No Continuous Output
---	---

If *CONT1= YES* (Continuous Output) is selected, an additional prompt, *TYPE1=* will be displayed.

If *CONT1= NO* (No Continuous Output) is selected, proceed to the Weight On Demand section.

TYPE1= (Continuous 1 Output Format)

Press the **ENTER** key to show the current value. If the setting displayed is acceptable, press the **ENTER** key again to save it. Otherwise, using the numeric keys enter the new setting, then press the **ENTER** key to save it. Allowable values are:

0 = SMA	1 = SB-400	2 = SB-200
3 = Rice Lake IQ355	4 = AnDFV	5 = WI110
6 = Number Only	7 = Toledo Long/Short	8 = SB500 with Traffic Light
9 = Ranger 5000 Format A		

SIO 2? (Setup Serial Port 2)

Press the **ENTER** key. The display will change to show the current setting *NO*. To skip configuring the *SIO PORT 2* (serial input/output) and proceed to the *SIO 3?* menu, press the **ENTER** key again. To configure the *SIO 2*, press the numeric key **1/YES** (display will change to *YES*) and then press the **ENTER** key.

BAUD2= (Serial Port 2 Baud Rate)

Press the **ENTER** key to show the current value. If the setting displayed is acceptable, press the **ENTER** key again to save it. Otherwise, use the numeric keys to enter a new baud rate for the serial ports, then press the **ENTER** key to save it. Allowable values are:

12 = 1200 Baud	24 = 2400 Baud	48 = 4800 Baud
96 = 9600 Baud	14 = 14.4k Baud	19 = 19.2k Baud
28 = 28.8k Baud	38 = 38.4k Baud	57 = 57.6k Baud
76 = 76.8k Baud	11 = 115.2k Baud	23 = 230.4k Baud

PRTY2= (Serial Port 2 Parity)

Press the **ENTER** key to show the current value. If the setting displayed is acceptable, press the **ENTER** key again to save it. Otherwise, using the numeric keys enter the new setting, then press the **ENTER** key to save it. Allowable values are: 0, 1, or 2.

0 = NONE (No Parity)	1 = Odd Parity	2 = Even Parity
----------------------	----------------	-----------------

BITS2= (Serial Port 2 Data Bits)

Press the **ENTER** key to show the current value. If the setting displayed is acceptable, press the **ENTER** key again to save it. Otherwise, using the numeric keys enter the new setting, then press the **ENTER** key to save it. Allowable values are: 7 or 8.

STOP2= (Serial Port 2 Stop Bits)

Press the **ENTER** key to show the current value. If the setting displayed is acceptable, press the **ENTER** key again to save it. Otherwise, using the numeric keys enter the new setting, then press the **ENTER** key to save it. Allowable values are: 1 or 2.

CONT2= (Continuous Output Serial Port 2)

Press the **ENTER** key to show the current value. If the setting displayed is acceptable, press the **ENTER** key again to save it. Otherwise, using the numeric keys, **0/NO** or **1/YES**, enter the new setting, then press the **ENTER** key to save it.

CONT2= YES

Continuous Output

CONT2= NO

No Continuous Output

If *CONT2= YES* (Continuous Output) is selected, an additional prompt, *TYPE2=* will be displayed.

If *CONT2= NO* (No Continuous Output) is selected, proceed to the Weight On Demand section.

TYPE2= (Continuous 2 Output Format)

Press the **ENTER** key to show the current value. If the setting displayed is acceptable, press the **ENTER** key again to save it. Otherwise, using the numeric keys enter the new setting, then press the **ENTER** key to save it. Allowable values are:

0 = SMA	1 = SB-400	2 = SB-200
3 = Rice Lake IQ355	4 = AnDFV	5 = WI110
6 = Number Only	7 = Toledo Long/Short	8 = SB500 with Traffic Light
9 = Ranger 5000 Format A		

SIO 3? (Setup Serial Port 3)

Press the **ENTER** key. The display will change to show the current setting *NO*. To skip configuring the *SIO PORT 3* (serial input/output), and proceed to the *PRINT?* menu, press the **ENTER** key again. To configure the *SIO 3*, press the numeric key **1/YES** (display will change to *YES*) and then press the **ENTER** key.

BAUD3= (Serial Port 3 Baud Rate)

Press the **ENTER** key to show the current value. If the setting displayed is acceptable, press the **ENTER** key again to save it. Otherwise, use the numeric keys to enter a new baud rate for the serial ports, then press the **ENTER** key to save it. Allowable values are:

12 = 1200 Baud	24 = 2400 Baud	48 = 4800 Baud
96 = 9600 Baud	14 = 14.4k Baud	19 = 19.2k Baud
28 = 28.8k Baud	38 = 38.4k Baud	57 = 57.6k Baud
76 = 76.8k Baud	11 = 115.2k Baud	23 = 230.4k Baud

PRTY3= (Serial Port 3 Parity)

Press the **ENTER** key to show the current value. If the setting displayed is acceptable, press the **ENTER** key again to save it. Otherwise, using the numeric keys enter the new setting, then press the **ENTER** key to save it. Allowable values are: 0, 1, or 2.

0 = NONE (No Parity)	1 = Odd Parity	2 = Even Parity
----------------------	----------------	-----------------

BITS3= (Serial Port 3 Data Bits)

Press the **ENTER** key to show the current value. If the setting displayed is acceptable, press the **ENTER** key again to save it. Otherwise, using the numeric keys enter the new setting, then press the **ENTER** key to save it. Allowable values are: 7 or 8.

STOP3= (Serial Port 3 Stop Bits)

Press the **ENTER** key to show the current value. If the setting displayed is acceptable, press the **ENTER** key again to save it. Otherwise, using the numeric keys enter the new setting, then press the **ENTER** key to save it. Allowable values are: 1 or 2.

CONT3= (Continuous Output Serial Port 3)

Press the **ENTER** key to show the current value. If the setting displayed is acceptable, press the **ENTER** key again to save it. Otherwise, using the numeric keys, **0/NO** or **1/YES**, enter the new setting, then press the **ENTER** key to save it.

CONT3= YES Continuous Output	CONT3= NO No Continuous Output
--	--

If *CONT3= YES* (Continuous Output) is selected, an additional prompt, *TYPE3=* will be displayed.

If *CONT3= NO* (No Continuous Output) is selected, proceed to the Weight On Demand section.

TYPE3= (Continuous 3 Output Format)

Press the **ENTER** key to show the current value. If the setting displayed is acceptable, press the **ENTER** key again to save it. Otherwise, using the numeric keys enter the new setting, then press the **ENTER** key to save it. Allowable values are:

0 = SMA	1 = SB-400	2 = SB-200
3 = Rice Lake IQ355	4 = AnDFV	5 = WI110
6 = Number Only	7 = Toledo Long/Short	8 = SB500 with Traffic Light
9 = Ranger 5000 Format A		

THRS= (Threshold Weight)

If any of the Serial Ports have been configured for continuous SB-500 with Traffic Light output, this prompt will be displayed.

Press the **ENTER** key to show the current value. If the setting displayed is acceptable, press the **ENTER** key again to save it. Otherwise, use the numeric keys to enter a new value for the threshold weight or enter a zero (0) to disable the traffic light and then press the **ENTER** key to save it.

The threshold weight is used to automatically toggle between the Red and Green lights.

- When the scale gross weight is less than the threshold weight, the Green light will be on, otherwise the Red light will turn on and stay on until the weight goes below the threshold weight or a ticket is printed.
- When a ticket is printed, the Green light will turn on and stay on until the scale gross weight goes below and back above the threshold weight and then the Red light will turn on.
- **NOTE:** If you enter a zero (0) for the threshold weight (*THRS=0*), the traffic light feature will be disabled (turned off).

PRINT (PRINT?) - Print Tab Settings

With *PRINT (PRINT?)* displayed, press the **ENTER** key. The display will change to show the current setting *NO*. To skip configuring the Print Tab Settings and proceed to the *F5PRINT?* menu, press the **ENTER** key again. To configure Print Tab Settings, press the numeric key **1/YES** (display will change to *YES*) and then the **ENTER** key. After pressing the **ENTER** key the display will change to *PORT=*.

The general format for the input is $A = YY.XX$ where A is the character identifying the data printed, YY is the number of lines down and XX is the number of spaces to the right.

NOTE: Enter 00 in either the YY or XX location to disable the data from printing.

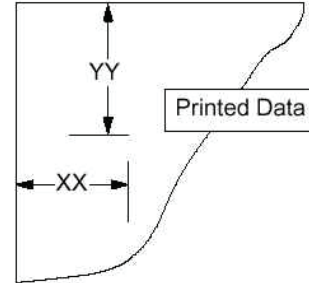

PORT= (Select Port for Printer)

Press the **ENTER** key to show the current value. If the setting displayed is acceptable, press the **ENTER** key again to save it. Otherwise, use the numeric keys to enter a new setting and then press the **ENTER** key to save it. Allowable values are: 0, 1, 2 or 3 (for port 0 through port 3) and 4 for the optional 2xx-RS232 card (if installed).

HOUR= (Time Print Location)

Press the **ENTER** key to show the current setting for the location of time printing. If the setting displayed is acceptable, press the **ENTER** key again to save it. Otherwise, use the numeric keys to enter a new location and then press **ENTER** to save it.

DATE= (Date Print Location)

Press the **ENTER** key to show the current setting for the location of date printing. If the setting displayed is acceptable, press the **ENTER** key again to save it. Otherwise, use the numeric keys to enter a new location and then press **ENTER** to save it.

ID = (ID Prompt Print Location)

Press the **ENTER** key to show the current setting for the location of ID prompt printing. If the setting displayed is acceptable, press the **ENTER** key again to save it. Otherwise, use the numeric keys to enter a new location and then press **ENTER** to save it.

CNC N= (Consecutive Number Print Location)

Press the **ENTER** key to show the current setting for the location of consecutive number printing. If the setting displayed is acceptable, press the **ENTER** key again to save it. Otherwise, use the numeric keys to enter a new location and then press **ENTER** to save it.

GROSS= (Gross Weight Print Location)

Press the **ENTER** key to show the current setting for the location of Gross weight printing. If the setting displayed is acceptable, press the **ENTER** key again to save it. Otherwise, use the numeric keys to enter a new location and then press **ENTER** to save it.

TARE= (Tare Weight Print Location)

Press the **ENTER** key to show the current setting for the location of Tare weight printing. If the setting displayed is acceptable, press the **ENTER** key again to save it. Otherwise, use the numeric keys to enter a new location and then press **ENTER** to save it.

NET= (Net Weight Print Location)

Press the **ENTER** key to show the current setting for the location of Net weight printing. If the setting displayed is acceptable, press the **ENTER** key again to save it. Otherwise, use the numeric keys to enter a new location and then press **ENTER** to save it.

G ACC= (Gross Weight Accumulator Print Location)

Press the **ENTER** key to show the current setting for the location of Gross weight accumulator printing. If the setting displayed is acceptable, press the **ENTER** key again to save it. Otherwise, use the numeric keys to enter a new location and then press **ENTER** to save it.

N ACC= (Net Weight Accumulator Print Location)

Press the **ENTER** key to show the current setting for the location of Net weight accumulator printing. If the setting displayed is acceptable, press the **ENTER** key again to save it. Otherwise, use the numeric keys to enter a new location and then press **ENTER** to save it.

COUNT= (Count "number of pieces on the scale" Print Location)

Press the **ENTER** key to show the current setting for the location of Count (number of pieces on scale) printing. If the setting displayed is acceptable, press the **ENTER** key again to save it. Otherwise, use the numeric keys to enter a new location and then press **ENTER** to save it.

EACH= (Piece Weight Print Location)

Press the **ENTER** key to show the current setting for the location of Piece weight printing. If the setting displayed is acceptable, press the **ENTER** key again to save it. Otherwise, use the numeric keys to enter a new location and then press **ENTER** to save it.

CRLF= (Carriage Return Line Feed) - Data Format Termination

Data transmitted from the serial I/O port can be terminated with a single carriage return and either no line feed or a single line feed command. Press the **ENTER** key to view the current setting. A "YES" displayed means the data will be terminated with a carriage return AND a line feed. A "no" displayed means the data will be terminated with a single carriage return only.

If the setting displayed is acceptable, press the **ENTER** key again to save it. Otherwise, using the numeric keys, **0/NO** or **1/YES**, enter the new setting and then press the **ENTER** key to save it.

EDP= (End-Of-Print Line Feeds)

At the end of a data transmission to a printer, the indicator can transmit a pre-selected number of line feed commands to space the paper in the printer to the desired position for withdrawal or for the next print.

Press the **ENTER** key to view the current setting. If the displayed value is acceptable, press the **ENTER** key to save it. Otherwise, use the numeric keys to enter the new the number of End-Of-Print linefeeds and then press the **ENTER** key to save the new setting. Allowable values are: 0 through 99.

F SPAN (FSPAN?) – Fine Span Adjustment



NOTE: The FSPAN and Hi rES modes require a load of 10% of Capacity be on the scale before adjustments can be made.

With the *F SPAN?* prompt displayed after pressing the **ENTER** key at the last Print prompt:

With *FSPAN?* displayed, press the **ENTER** key. The display will change to show the current setting *NO*. To skip the Fine Span Adjustment and return to the *SETUP* menu, press the **ENTER** key again. To perform the Fine Span Adjustment, place a calibrated test weight on the scale, press the numeric key **1/YES** (display will change to *YES*) and then the **ENTER** key.

After pressing the **ENTER** key, the display will change to show the amount of the test weight and the annunciators will alternately flash off and on i.e. (all ON, weighing unit off, then all OFF, weighing unit ON). Press the **1/YES** to increase the span OR press the **0/NO** key to decrease the span. Press the ***** key to return to the previous prompt or press the **ENTER** key to exit *FSPAN?* and return to the *SETUP* menu.

With the *F SPAN* prompt displayed after pressing the Calibration switch:

With *F SPAN* displayed, place a calibrated test weight on the scale and press the **ENTER** key. After pressing the **ENTER** key, the display will change to show the amount of the test weight and the annunciators will alternately flash off and on (all ON, weighing unit off, then all OFF, weighing unit ON). Press the **1/YES** to increase the span OR press the **0/NO** key to decrease the span. Press the ***** key to return to the previous prompt or press the **ENTER** key to exit *F SPAN* and return to the *SETUP* menu.

HI RES – Display High Resolution Weight

With *HI RES* on the display, pressing the **ENTER** key will show the active weight in "high resolution" mode (in 1/10 interval). Press the **PRINT** key to print the weight (followed by the text *TEST*) via the selected printer output port enabled during setup and calibration. Press the **ENTER** key to return to the *HI RES* prompt. To exit the *HI RES* mode, press the calibration switch or cycle power (press the **ON/OFF** key twice).

LOCOUT – Key Lock Out Function

With *LOCOUT* on the display, pressing *any* key will display *LOCKED* (locked) or *UNLOCKED* (unlocked) for the current key state. Pressing a locked key during normal operation will result in a 1/2 second display *LOCKED* and the key will be ignored. To exit the *LOCOUT* function, press the calibration switch or cycle power (press the **ON/OFF** key twice).



NOTE: The menu selections *HI RES* and *LOCOUT* can only be selected using the calibration switch.

OPTION – Option Card Configuration

This prompt will **ONLY** be displayed when a 2XX Option Card is installed in the indicator. Refer to the manual for the 2XX option card installed for setup instructions.

SETUP REVIEW

The 212G/212GX indicators allow several operational parameters to be reviewed and changed without breaking the calibration seal. These operational parameters are:

- Light Sensor Reading
- Backlight Threshold Setting
- Power Up Zero Reset Enable/Disable
- Time Format
- Sleep Mode Feature Enable/Disable
- Auto Shutoff Feature Enable/Disable

- Serial Input / Output Configuration
 - Baud Rate
 - Parity
 - Number of Data Bits
 - Number of Stop Bits
 - Continuous Output Port 1
 - Continuous Output Format
 - Continuous Output Port 2
 - Continuous Output Format

- Print Tab Settings
 - Printer Port Selection
 - Time
 - Date
 - Consecutive Number
 - Gross Weight
 - Tare Weight
 - Net Weight
 - Gross Weight Accumulator
 - Net Weight Accumulator
 - Count
 - Piece Weight

To enable the Setup Review feature, with the indicator ON:

1. Press the * key. The indicator will respond by showing the *FUNC*= (Function) prompt and alternately flashing off and on (all ON, weighing unit off, then all OFF, weighing unit ON) the annunciators.
2. Press the **ZERO/REVIEW** key. The display will change to the current light sensor reading (*LT*=). Refer to the next section DISPLAY BACKLIGHT BRIGHTNESS for instructions on adjusting the display backlight brightness.
3. If the settings displayed for each prompt is acceptable, press the **ENTER** key again to save it and proceed to the next prompt. Otherwise, use the same procedure as described in the Setup and Calibration section of this manual for each prompt to make the required changes.
4. Note that you can press the * key to return to the previous prompt.
5. To exit, press the **ENTER** key to step through the remaining prompts *OR* at anytime, cycle the power (press the **ON/OFF** key twice).

CALIBRATION "C" NUMBERS

The "C" numbers are displayed only during the Test mode operation by pressing the * key then the **UNITS/TEST** key. The "C" numbers are shown at the end of the test operation and each number is displayed for approximately 4 seconds, allowing you to record them. Each number may be up to three (3) digits in length. By recording these numbers you will be able to return the indicator to its present calibration settings without using test weights simply by entering the "C" numbers.

1. With ϵ_{RL} displayed, press the "diamond T" **TARE** key.
2. At the ϵ_1 prompt, press the **ENTER** key to show the current value of the ϵ_1 number.
3. If the ϵ_1 number displayed is acceptable, press the **ENTER** key again to save it.
4. Otherwise, use the numeric keys to enter a new ϵ_1 number, then press the **ENTER** key.
5. Repeat steps 2 through 4 for ϵ_2 , ϵ_3 and ϵ_4 .



If any components have been changed that affect calibration and/or your scale is used in a commercial application and must be "Legal for Trade" you cannot use "C" numbers to re-calibrate.

DISPLAY BACKLIGHT THRESHOLD

With the indicator ON:

1. Press the ***** key. The indicator will respond by showing the *FUNCT=* (Function) prompt and alternately flashing off and on (all ON, weighing unit off, then all OFF, weighing unit ON) the annunciators.
2. Press the **ZERO/REVIEW** key. The display will change to the current light sensor reading (*LT=*).

LT= XXX Current LCD Light Sensor Reading (where XXX is the current value)
NOTE: This value is not adjustable.

LSET= Light Sensor Reading at which LCD Backlight will turn ON. Note that the LCD Backlight will turn OFF at the *LSET=* value plus 10.

For example, if *LSET=* is 5, then the backlight will turn ON when the *LT=* reading is 5 and turn OFF when the *LT=* reading is 15.

If the setting displayed is acceptable, press the **ENTER** key again to save it. Otherwise, using the numeric keys, enter the new setting and then press the **ENTER** key to save it and advance to the next prompt.

Allowable settings are 0 to 255.

3. Press the ***** key to return to the previous prompt.
4. To exit, press the **ENTER** key to step through the remaining prompts *OR* at anytime, cycle the power (press the **ON/OFF** key twice).

ACCUMULATORS

To *view* the **NET** accumulator:

1. Press the * key then the **NET/GROSS** key.
2. Press the * key to return to normal operation.

To *print* the **NET** accumulator:

1. Press the * key, the **NET/GROSS** key, then the **PRINT** key
2. The indicator will return to normal operation when printing has been completed.

To *clear (zero)* the **NET** accumulator:

1. Press the * key, the **NET/GROSS** key, then the **ZERO** key
2. Press the * key to return to normal operation.

To *view* the **Gross** accumulator:

1. Press the * key then the **NET/GROSS** key twice.
2. Press the * key to return to normal operation.

To *print* the **Gross** accumulator:

1. Press the * key, the **NET/GROSS** key twice, then the **PRINT** key
2. The indicator will return to normal operation when printing has been completed.

To *clear (zero)* the **Gross** accumulator:

1. Press the * key, the **NET/GROSS** key twice, then the **ZERO** key
2. Press the * key to return to normal operation.

To *view* the **Count** accumulator:

1. Press the * key then the **COUNT/SAMPLE** key.
2. Press the * key to return to normal operation.

To *print* the **Count** accumulator:

1. Press the * key, the **COUNT/SAMPLE** key, then the **PRINT** key
2. The indicator will return to normal operation when printing has been completed.

To *clear (zero)* the **Count** accumulator:

1. Press the * key, the **COUNT/SAMPLE** key, then the **ZERO** key
2. Press the * key to return to normal operation.

ERROR CODES

The 212G/212GX indicators are equipped with software that indicates when an error in the operation takes place. The following lists the error codes displayed by the 212G/212GX along with their meaning. Should you encounter an error code, please refer to this list for the cause.

***CALBTN* (Calibration button)**

CALBTN will be displayed (until the condition changes), on power-up if the calibration switch is pressed in by the operator, the calibration access screw is the wrong length and is depressing the switch, the switch is disconnected from the PC board, or the switch is defective.

CORRECTIVE ACTION: Release the switch. Insure correct screw (#10 x ½ Stainless Steel fillister head) was installed for the calibration access screw. Referring to Figure No. 6, make sure calibration switch cable is plugged into P7 on the PC board. Replace calibration switch assembly. Consult your scale service provider.

***CONFIG* (Configuration)**

E²PROM checksum failure. Indicates improper stored calibration data, calibration is necessary.

CORRECTIVE ACTION: Recalibrate with calibrated test weight.

***ERROR* (Error)**

An invalid keypad entry was attempted:

- A. **PRINT** key pressed with a negative weight.
- B. **TARE** key pressed to enter a push button tare value of a negative value.
- C. **ENTER** key pressed to enter a tare weight value that exceeds the scale capacity.
- D. **ENTER** key pressed to enter a tare weight value that is inconsistent with the scale division value (i.e. attempt to enter a tare of 123 with scale divisions of 5).
- E. **ZERO** key pressed when the gross weight is outside the scale zero weight range.
- F. **lb/kg** key pressed to change to kg when the kg tare weight value exceeds 4 digits in length.

CORRECTIVE ACTION: Determine which of the reasons for the error display is applicable and take the appropriate corrective action.

***ERRAH* (Error Analog high)**

1. The load cell input is above the range of the indicator.

CORRECTIVE ACTION: Check for improper load cell wiring, excessive load, and for output of 1 to 40mV.

2. Load cell or circuit failure.

CORRECTIVE ACTION: Consult your scale service provider.

***ERRAL* (Error Analog Low)**

1. The load cell input is below the range of the indicator.

CORRECTIVE ACTION: Check for improper load cell wiring and for output of 1 to 40mV.

2. Load cell or circuit failure.

CORRECTIVE ACTION: Consult your scale service provider.

EEFAIL (External EEPROM memory write/read failure)

ID storage will not operate correctly. Occurs once at Start-Up.

CORRECTIVE ACTION: Press any key to continue. No other action is necessary if ID storage is not used. Consult your scale service provider.

EE ERR (External EEPROM memory retention error)

ID storage will not operate correctly. Occurs once at Start-Up.

CORRECTIVE ACTION: Press any key to continue. No other action is necessary if ID storage is not used. Consult your scale service provider.

-EE- (External EEPROM memory is being initialized/erased)

Displayed momentarily at Start-Up, for about 2 seconds, if previous initialization was unsuccessful.

CORRECTIVE ACTION: No action is necessary.

HUHP (HuH?)

UNITS key pressed in an attempt to perform a unit conversion that is not allowed.

CORRECTIVE ACTION: Determine the reason for the error display and take the appropriate corrective action.

IICERR (IIC bus failure)

ID storage, Time & Date, or other functions that use the IIC bus will not operate correctly. Occurs once at Start-Up.

CORRECTIVE ACTION: Press any key to continue. Consult your scale service provider.

NOTARE (no tarE)

NET key pressed with no stored tare weight value.

CORRECTIVE ACTION: Determine the reason for the error display and take the appropriate corrective action.

DCAP (over Capacity)

The load on the scale exceeds the scale capacity plus nine (9) divisions.

CORRECTIVE ACTION: Remove the over capacity load from the scale platform. May indicate miscalibration.

-DF- (overflow)

The indicator is attempting to display a positive number greater than six (6) digits in length or a negative number of more than five (5) digits.

CORRECTIVE ACTION: Return to Gross Weight mode and review Tare value. May indicate miscalibration.

TOOBIG (too big)

UNITS key pressed in an attempt to perform a unit conversion where the interval would have been greater than 50.

CORRECTIVE ACTION: Determine the reason for the error display and take the appropriate corrective action.

UNSTB (Unstable)

Motion is present when trying to perform a print function.

CORRECTIVE ACTION: Wait for a stable weight display (*STABLE* annunciator on) before performing any of this operation.

BEFORE YOU CALL FOR SERVICE

The 212G/212GX indicators have been designed to provide you with years of trouble-free operation. However, should you experience a problem, please refer to the troubleshooting guide below before you call for service. The following describes several types of symptoms along with suggested remedies.

PROBLEM	POSSIBLE SOLUTIONS
Display does not turn on	<p>AC operation:</p> <p>Is the AC power cord fully inserted into the wall receptacle? Check wall receptacle for proper AC power. Try another electrical appliance in the same receptacle, does it work? Check the circuit breaker. Has there been power failure?</p>
Incorrect weight displayed	<p>Has the indicator been calibrated? Insure that the scale platform isn't touching an adjacent object. Check the load cell connector wiring. If using four (4) wire load cells, insure the sense lead jumpers (J6 & J9) are installed. Have proper operation procedures been followed?</p>
Indicator will not display weight	<p>Refer to Error Codes section and make certain that the <i>OCAP</i> message is not displayed. If so, and scale is not loaded, perform the calibration sequence.</p>
The printer prints but does not use the Print Tab Settings or prints a test ticket	<p>The print tab setting or visual ticket format must be selected prior to beginning the weighing operation or just prior to printing the ticket.</p> <p>To select the ticket format prior to beginning the weighing operation:</p> <ol style="list-style-type: none"> 1. Press the * key then the PRINT key. The display will change to the <i>PRT=</i>. 2. Press the ENTER key to show the current value. 3. If the value displayed is acceptable, press the ENTER key again to save it. 4. If the displayed value is incorrect (or another ticket format is desired), use the numeric keys to enter the new value, then press the ENTER key to save it. <p>To select the ticket format just prior to printing the ticket:</p> <ol style="list-style-type: none"> 1. Press the desired format number. 2. Pressing the PRINT key. <p>Allowable values for ticket formats are:</p> <p style="padding-left: 40px;">0 = print tab settings 1 = visual ticket format 1 2 = visual ticket format 2</p> <p>NOTE: When a print format is selected (by either method), it will remain active until changed by the operator.</p>

CALIBRATION SEAL INSTALLATION

If your 212G/212GX Weight Indicating Instrument is used in a commercial application it must be tested and sealed by your local weights and measurements official. The 212G/212GX has been designed to accept a lead and wire security seal to prevent unauthorized access to the calibration adjustments. Refer to Figure No. 19 for details on the installation of the seal.



Figure No. 19

ID STORAGE OPERATION

The ID Storage feature has been designed to control three different types of transactions and weighing operations. The first type of transaction assigns a permanent ID string, has a stored tare weight, and accumulates net weight totals for the ID. The second type assigns a permanent ID string and accumulates net weight totals for the ID, but does not have a permanent stored weight. The third type temporarily assigns an ID string (while weighing in) and does not accumulate any net weight totals for the ID.

PERMANENT

Single Pass Transaction (One-Step Operation)

The first type of permanent transaction is a "single pass" transaction and is used to weigh loaded containers with a permanent ID string and a previously stored tare weight. The stored tare weight requires weighing the empty container in advance or if the weight of the empty container is known, by entering that value as a manual tare weight. The single pass transaction completes a ticket and accumulates the net weight for the ID associated with the container with a "one-step" weighing operation.

Two Pass Transaction (Two Step Operation)

The second type of permanent transaction is a "two pass" transaction and is used to weigh the loaded container once when it is empty and once when it is loaded. A permanent ID string and a previously stored zero (0) tare weight is required. In the two pass transaction, the zero tare weight is replaced by the new tare weight after the first pass and returned to zero after the second pass when the transaction has been completed. The two pass transaction requires a "two-step" weighing operation. On the first step, the incoming weight will be stored and an interim ticket will be printed. On the second step, during the outgoing transaction, a complete ticket will be printed and the net weight for the ID associated with the container will be added to the accumulator.

TEMPORARY

Two Pass Transaction (Two Step Operation)

The third type is a temporary "two pass" transaction that also requires a "two-step" operation. However, the ID string is only in memory while the container is weighed in and out and the net weight will not be accumulated. In this type of transaction, on the first pass, the container will be placed on the scale and an ID will be selected either by the operator entering an ID string or by the indicator automatically assigning the ID string. The weight will be stored and an interim ticket will be printed. On the second pass, the ID string is entered and the stored weight is recalled for printing the complete ticket. After the ticket has printed, the ID number and the stored weight will be removed from memory.

Gross Weight Alarm

If *ALARM?*=YES was selected setup, then when the **PRESET** key is pressed the *ALR WT* prompt is displayed. Press the **ENTER** key, the current weight value is displayed, if this value is acceptable press the **ENTER** key, otherwise, use the numeric keys to enter a new alarm weight and press the **ENTER** key.

NOTE: The gross weight must fall below 1/2 the preset weight before the alarm is re-armed.

The *ALR TI* prompt is displayed, press the **ENTER** key and the alarm time on value in seconds will be displayed. If the value is acceptable, press the **ENTER** key, otherwise, use the numeric key to enter a new alarm time value and press the **ENTER** key. The alarm time may be from 0 to 99 seconds.

NOTE: If the alarm time setting is zero, then the alarm is disabled.

Permanent Identification (ID) Strings

To Add A Permanent ID String

1. With the indicator in normal operations mode, press the * key. The display will change *FUNCT=*, press the **F** key.
2. Enter up to a 6-digit alphanumeric ID string and press the **ENTER** key.
3. The display will show *TARE=*, press the **ENTER** key. A 0 stored tare weight will be displayed, if the displayed weight is acceptable press the **ENTER** key, otherwise, use the numeric keys to enter the new tare weight and press **ENTER**, or press the **NET** key to store the current Gross weight as the new stored tare weight.
4. The display will change to *ACCUM=*, press the **ENTER** key to show a zero value for the accumulator associated with this ID.
5. If a zero value is correct, press the **ENTER** key to save it. Otherwise, using the numeric keys enter the accumulator value and then press the **ENTER** key to save it.
6. The display will change to *LORDS=*, press the **ENTER** key to show a zero value for the number of loads associated with this ID.
7. If a zero value is correct, press the **ENTER** key to save it. Otherwise, using the numeric keys enter the number of loads and then press the **ENTER** key to save it.
8. The indicator will return to normal operation.

To Edit or View A Permanent ID String

1. With the indicator in normal operations mode, press the * key. The display will change *FUNCT=*, press the **F** key.
2. Enter up to a 6-digit alphanumeric ID string and press the **ENTER** key.
3. The display will show *TARE=*, press the **ENTER** key. The stored tare weight will be displayed. If the displayed weight is acceptable press the **ENTER** key, otherwise, use the numeric keys to enter the new tare weight and press **ENTER**, or press the **NET** key to store the current Gross weight as the new stored tare weight.
4. The display will change to *ACCUM=*, press the **ENTER** key to show the current accumulator weight that is associated with this ID.
5. If the accumulator value is correct, press the **ENTER** key to save it. Otherwise, using the numeric keys enter a new accumulator value and then press the **ENTER** key to save it.
6. The display will change to *LORDS=*, press the **ENTER** key to show the current number of loads that are associated with this ID.
7. If the number of loads is correct, press the **ENTER** key to save it. Otherwise, using the numeric keys enter the new number of loads and then press the **ENTER** key to save it.
8. The indicator will return to normal operation.

Permanent Identification (ID) Strings, Cont.

To Delete A Permanent ID String

1. With the indicator in normal operations mode, press the * key. The display will change *FUNCT=*, press the **F** key.
2. Enter up to a 6-digit alphanumeric ID string and press the **F** key.
3. The *DEL ID* prompt will be displayed, to delete the ID press the **1/YES** key. The ID and its associated tare, accumulator, and loads will be deleted.
NOTE: To abort the delete operation, press the **0/NO** key.
4. If the entered ID does not exist, the *NOTFND* message will be displayed.

To Print A Permanent ID String

1. With the indicator in normal operations mode, press the * key. The display will change *FUNCT=*, press the **F** key.
2. Enter up to a 6-digit alphanumeric ID string and press the **PRINT** key.
3. The *PRT ID* prompt will be displayed, to print the ID press the **1/YES** key. The ID and its associated tare, accumulator, and loads will be printed.
NOTE: To abort the print operation, press the **0/NO** key.
4. If the entered ID does not exist, the *NOTFND* message will be displayed.

To Delete All Permanent ID Strings

1. With the indicator in normal operations mode, press the * key. The display will change *FUNCT=*, press the **F** key.
2. At the *ID=* prompt, press the **F** key.
3. The *DELALL* prompt will be displayed, to delete all of the IDs press the **1/YES** key. The IDs and their associated tare, accumulator, and loads will be deleted.
NOTE: To abort the print operation, press the **0/NO** key.
4. The indicator will return to normal operation.

To Print All ID Strings

1. With the indicator in normal operations mode, press the * key. The display will change *FUNCT=*, press the **F** key.
2. At the *ID=* prompt, press the **PRINT** key.
3. The *PRTALL* prompt will be displayed, to print all of the IDs press the **1/YES** key. The IDs and their associated tare, accumulator, and loads will be printed.
NOTE: To abort the print operation, press the **0/NO** key.
4. The indicator will return to normal operation.

To Print All ID Strings, Cont.

SAMPLE PRINTOUT: ID PRINTALL (PRTALL)

ID REPORT

08:45 1/17/2013

ID= 1

STORED WGHT= 100 lb K
ACCUMULATOR= 9143 lb
NO OF LOADS=1

ID= 2

STORED WGHT= 100 lb K
ACCUMULATOR= 9143 lb
NO OF LOADS=1

ID= 3

STORED WGHT= 1000 lb K
ACCUMULATOR= 8242 lb
NO OF LOADS=1

ID= 4

STORED WGHT= 1000 lb K
ACCUMULATOR= 8242 lb
NO OF LOADS=1

ID= 5

STORED WGHT= 100 lb K
ACCUMULATOR= 0 lb
NO OF LOADS=1

ID= 7

STORED WGHT= 100 lb K
ACCUMULATOR= 0 lb
NO OF LOADS=0

ID= 8

STORED WGHT= 100 lb K
ACCUMULATOR= 0 lb
NO OF LOADS=0

To Print All ID Strings, Cont.

IN-PROCESS (Temporary ID) REPORT

ID= 11
WEIGHT= 9242 lb

ID= A
WEIGHT= 9242 lb

ID= D
WEIGHT= 9242 lb

ID= G
WEIGHT= 9242 lb

ID= J
WEIGHT= 9242 lb

ID= M
WEIGHT= 9242 lb

PERMANENT ID

Single Pass Transaction (One-Step Operation)

The single pass transaction (one-step operation) is used to weigh LOADED containers with a permanent ID string and a *previously stored tare weight* associated with that ID string. This requires weighing the empty container in advance or if the empty weight is known, by entering that value as a manual tare weight when adding the permanent ID.

(Loaded Container)

1. With the indicator in normal operations mode, place the loaded container on the scale.
2. Press the **F** key. The display will change to show *ID=*. Press the **ENTER** key.
3. Enter up to a 6-digit alphanumeric ID string and press the **PRINT** key.
4. The Net weight will be added to the accumulator of the entered ID and the ticket printed will show the TIME, DATE, ID, the Gross, Tare, and Net weights. Also, the number of loads for the ID will be incremented.

Two Pass Transaction (Two-Step Operation)

The two pass transaction is a two-step operation used to weigh the container once when it is empty and once when it is loaded. A permanent ID string and a *previously stored zero tare weight* associated with that ID string is required.

In the two pass transaction, the zero tare weight will be replaced by the new tare weight after the first pass and the stored weight will return to zero after the second pass.

On the first step, the incoming weight will be stored and an interim ticket will be printed. On the second step, during the outgoing transaction, a complete ticket will be generated and the net weight will be added to the permanent ID string accumulator. Also, the number of loads will be incremented. .

(Empty or Loaded Container)

Step 1

1. With the indicator in normal operations mode, place the empty/loaded container on the scale.
 2. Press the **F** key. The display will change to show *ID=*. Press the **ENTER** key.
 3. Enter up to a 6-digit alphanumeric ID string and press the **ENTER** key.
- NOTE:** If a ticket is desired, press the **PRINT** key to store the weight and print the ticket.
4. The display will momentarily show *PASS 1* and then return to the Gross weight display.

Step 2

1. With the indicator in normal operations mode, place the loaded/empty container on the scale.
2. Press the **F** key. The display will change to show *ID=*. Press the **ENTER** key.
3. Enter up to a 6-digit alphanumeric ID string and press the **PRINT** key.
4. The display will momentarily show *PASS 2* and then return to the Gross weight display.
5. The Net weight will be added to the accumulator and the number of loads will be incremented for the entered ID. The ticket printed will show the TIME, DATE, ID, TIME/DATE of Stored Tare weight, the Gross, Tare, and Net weights.

TEMPORARY ID

Two Pass Transaction (Two-Step Operation)

NOTE: If the ID string entered already exists, the display will show *IDNUSE* momentarily and the indicator will return to normal operation.

(Store a Temporary ID String and Print)

First Pass

1. With the indicator in normal operations mode, place the empty/loaded container on the scale.
2. Press the **F** key. The display will change to show *ID=*, press the **ENTER** key.
3. Enter up to a 6-digit alphanumeric ID string and press the **ENTER** key to store the weight.

NOTE: If a ticket is desired, press the **PRINT** key to store the weight and print the ticket.

4. The display will momentarily show *PASS 1* and then return to the Gross weight display

Second Pass

1. With the indicator in normal operations mode, place the loaded/empty container on the scale.
2. Press the **F** key. The display will change to show *ID=*, press the **ENTER** key.
3. Enter up to a 6-digit alphanumeric ID string and press the **PRINT** key.
4. The display will momentarily show *PASS 2* and the ticket printed will show the TIME, DATE, ID, the Gross, Tare, and Net weights, and then return to the Gross weight display.

Automatically Assign A Temporary ID String

First Pass

1. With the indicator in normal operations mode, place the empty/loaded container on the scale.
2. Press the **F** key. The display will change to show *ID=*, press the **ENTER** key.
3. Press the **PRINT** key, a ticket is printed with the automatically assigned ID.
4. The display will momentarily show *PASS 1* and then return to the Gross weight display

Second Pass

1. With the indicator in normal operations mode, place the loaded/empty container on the scale.
2. Press the **F** key. The display will change to show *ID=*, press the **ENTER** key.
3. Use the numeric keys to enter the ID printed on the first pass ticket and press the **PRINT** key.
4. The display will momentarily show *PASS 2* and the ticket printed will show the TIME, DATE, ID, the Gross, Tare, and Net weights, and then return to the Gross weight display.

To Delete ALL Temporary (IN PROCESS) ID Strings

1. Press the **F** key twice. The display will change to show *DELALL*.
2. Press the **ENTER** key. The display will change to show *NO*.
3. Press the **1/YES** key.. The display will change to show *YES*.
4. Press the **ENTER** key.
5. ALL temporary ID's are deleted.

DIGITAL FILL CONTROL MODE OPERATION

The Digital Fill Control (DFC) feature has been designed to control the filling or discharge of material automatically using relays in an external enclosure. The DFC adds a number of operation features to the indicator. Those features include:

Start Validation

Pressing the **F** key changes the display to *START?*, press the **ENTER** key and the display changes to *YES*. To start the fill, press the **ENTER** key. To abort the fill, press the **0/NO** key and then the **ENTER** key.

Single or Two Speed or Two Speed Operation

The single speed operation provides a single output control. The two speed operation provides a two relay (fast and slow) output control.

The two speed operation without chatter gate control, depending on the gate sequence (*G SEQ=1, 2, or 3*) setting at setup, can begin the fill operation with one or two relay output controls (fast and slow) on until the weight reaches the *FAST=* value. At that weight, the fast output will be turned off and only the slow output will remain on until the *SLOW=* weight less the *TRIM=* weight value is reached.

Two Speed Operation with Chatter Gate

The two speed with Chatter Gate operation uses only the fast relay control output. It will begin the fill operation with the fast relay control output on and cycle the fast relay from continuous on to chatter when the weight reaches the *FAST=* weight value. At that weight, the fast relay will be turned on for the preset chatter time (*CT ON=*) 0.1 to 99.9 seconds and then turned off. When the weight reading becomes stable, the weight value will be compared to the *SLOW=* value less the *TRIM=* value. If the weight is less than the preset *SLOW=* value less the *TRIM=* value the fast relay will again be turned on for the preset chatter time (*CT ON=*) 0.1 to 99.9 seconds and then turned off. This will be repeated until the container weight is equal to or greater than the *SLOW=* value less the *TRIM=* value.

Dump Gate (Auto Discharge or Manual Discharge)

If *DGATE=YES* and *ADISC=YES*, the completed fill operation will immediately discharge and PWC3 annunciator will be on indicating that dumping is taking place. The discharge will continue until the scale weight returns to zero within the *ZERO TOL=XX* value. At this point the dump gate timer will turn on and maintain the gate open until the timer has expired at which time the gate will close.

If *ADISC=NO*, the indicator will halt after filling and will wait for the **DUMP** key to be pressed (or a remote manual dump command) before the material is discharged and the next fill started.

Auto Trim

Auto Trim option is a feature that will automatically adjust the trim weight value, after every completed fill operation, to achieve accurate fill weights. For example, if the preset *SLOW* weight is set at 5000 lbs and the *TRIM* is set at 100 lbs, the cut-off will be at 4900 lbs. If the actual weight of the trim is 50 lbs, the total weight of the material discharged will be 4950 lbs, not 5000. With Auto Trim enabled, starting with the next operation, the *TRIM* value will be gradually adjusted until the 5000 lbs preset weight total is achieved. Depending on how much difference there is between the programmed trim and the actual trim, it may take several operations before the full preset weight amount is reached.

Auto Print

This feature, when enabled, produces an automatic print of the delivered net or gross weight at the end of each fill operation. The following is an example of the information printed.

14:54 12/13/2012
#53
12000 lb G
00 lb T
12000 lb N

SINGLE SPEED OPERATION

USING STORED ID DFC SETTINGS:

To recall the stored settings from memory (setup parameter *STORP=YES*), press the * key and then the **PRESET** key. The display will show *STOR=*, press the **ENTER** key, the current ID (if any) will be displayed. If the displayed ID is correct, press the **ENTER** key, otherwise, enter the desired ID and press **ENTER**. If a new ID was entered, the Fill weight and trim weight will be retrieved from memory.

The display will change to show *FILL =*, press the **ENTER** key and the current fill weight will be displayed. If this value is acceptable press the **ENTER** key, otherwise, use the numeric keys to enter a new fill weight and press the **ENTER** key.

The display will change to show *TRIM =*, press the **ENTER** key and the current trim weight will be displayed. If this value is acceptable press the **ENTER** key, otherwise, use the numeric keys to enter a new trim weight and press the **ENTER** key.

NOTE: If the Fill or trim values are changed, they will **NOT** be saved to the ID in memory.

If the *DGATE=YES*, then the display will change to *0 TOL=*. Press the **ENTER** key and the current zero tolerance weight will be displayed. If this value is acceptable press the **ENTER** key, otherwise, use the numeric keys to enter a new zero tolerance weight and press the **ENTER** key.

The current Gross/Net weight will be displayed.

To Start a Fill Operation

1. Press the **F** key. If the gross weight is within the zero tolerance weight (*DGATE=YES*), the indicator will tare off the gross weight and display zero net weight (if *ATARE=YES*) and the display will show *START?*.

Note that if the Gross weight is not within the zero tolerance weight, *CKZERO* will be displayed momentarily.

2. Press the **ENTER** key to start the fill operation, or press the **NO** key and then the **ENTER** key to abort the operation.
3. The PWC1 enunciator will turn on and the PWC1 output control will turn on.
4. When the displayed weight reaches the *FILL=XXXXXX* value (minus the *TRIM=XXXXXX* value), the PWC1 output control is switched off and the PWC1 enunciator is turned off.
5. If the fill control parameters were retrieved from memory, then the filled weight will be added to the accumulator and the count will be incremented, and saved to the ID.
6. When all motion stops, the weight will be printed (if a printer is attached and *RPRINT=YES*). The following is an example of the information printed.

```
14:54 12/13/2008
#53
12000 lb G
00 lb T
12000 lb N
```

7. If *ATRIM=YES* was selected in setup, the trim weight will be recalculated and stored in memory and the displayed weight value added to the PRESET and GROSS or NET accumulators.
8. If *DGATE=YES* and *RDISC=YES* were selected in setup, then the completed fill operation will immediately begin to discharge and PWC3 enunciator and output control are turned on. The weight display will change from net to gross. The discharge will continue until the scale weight returns to zero within the *D TOL=XX* value.
9. If *DGATE=YES* and *RDISC=NO* were selected in setup, then the completed fill operation will wait for the **F** key or the optional **START** pushbutton to be pressed for the discharge to begin (PWC3 enunciator and output control are turned on). The weight display will change from net to gross. The discharge will continue until the scale weight returns to zero within the *D TOL=XX* value.

To Suspend (Pause) or Stop (Abort) a Fill Operation in Progress

The fill operation can be suspended (paused) or stopped (aborted) by the operator if needed.

1. To pause the filling operation, press the **F** key or press the optional **START** pushbutton.
2. The fill operation will be suspended (paused) and the *PAUSED* message will flash on the display.
3. To continue the fill operation, press the **F** key. If the optional **START** pushbutton is pressed go to step 7.
4. The *CONT ?* prompt will be displayed, press the **ENTER** key, the *NO* prompt will be displayed.
5. To stop (abort) the fill operation, press the **ENTER** key.
6. To continue the fill, press the **1/YES** key or the optional **START** pushbutton.
7. The 212G/212GX will return to normal operation, displaying the Gross weight on the scale.

NOTE: If *DGATE=YES*, the fill operation cannot be restarted after a STOP if the material weight is above the zero tolerance.

NOTE: If the optional **STOP** pushbutton is pressed, the fill operation will immediately be aborted.

TWO SPEED OPERATION

USING STORED ID DFC SETTINGS:

To recall the stored settings from memory (setup parameter *STORP=YES*), press the * key and then the **PRESET** key. The display will show *STOR=*, press the **ENTER** key, the current ID (if any) will be displayed. If the displayed ID is correct, press the **ENTER** key, otherwise, enter the desired ID and press **ENTER**. If a new ID was entered, the Fill weight and Trim weight will be retrieved from memory.

The display will change to show *FAST =*, press the **ENTER** key and the current fast weight will be displayed. If this value is acceptable press the **ENTER** key, otherwise, use the numeric keys to enter a new fast weight and press the **ENTER** key.

The display will change to show *SLOW =*, press the **ENTER** key and the current slow weight will be displayed. If this value is acceptable press the **ENTER** key, otherwise, use the numeric keys to enter a new slow weight and press the **ENTER** key.

NOTE: The slow weight is the target weight and **MUST** be greater than the fast weight.

The display will change to show *TRIM =*, press the **ENTER** key and the current trim weight will be displayed. If this value is acceptable press the **ENTER** key, otherwise, use the numeric keys to enter a new trim weight and press the **ENTER** key.

NOTE: If the Fast, SLOW, or trim values are changed, they will **NOT** be saved to the ID in memory.

If the *DGATE=YES*, then the display will change to *Z TOL=*. Press the **ENTER** key and the current zero tolerance weight will be displayed. If this value is acceptable press the **ENTER** key, otherwise, use the numeric keys to enter a new zero tolerance weight and press the **ENTER** key.

If the Chatter-Gate operation (*G SEQ=3*) was selected in setup, then the *CT ON=* prompt will be displayed. Press the **ENTER** key and the current time on setting will be displayed. If the time is acceptable the press the **ENTER** key, otherwise, use the numeric keys to enter a new time and press the **ENTER** key. The valid range is 0.00 to 99.9 seconds.

The current Gross/Net weight will be displayed.

To Start a Fill Operation

1. Press the **F** key. If the gross weight is within the zero tolerance weight (*DGATE=YES*), the indicator will tare off the gross weight and display zero net weight (if *ATARE=YES*) and the display will show *START?*.

Note that if the Gross weight is not within the zero tolerance weight, *CKZERO* will be displayed momentarily.
2. Press the **ENTER** key to start the fill operation, or press the **NO** key and then the **ENTER** key to abort the operation.
3. The PWC1 enunciator will turn on and the PWC1 output control will turn on. If the *G SEQ=1* (A->B) then the PWC2 enunciator will turn on and the PWC2 output control will turn on.
4. When the displayed weight reaches the *FAST=XXXXXX* value (minus the *TRIM=XXXXXX* value), the PWC1 output control is switched off and the PWC1 enunciator is turned off.
5. If *G SEQ=2* (A->B) then the PWC2 enunciator and output control will be turned on.
6. If *G SEQ=3* (Chatter-gate), then the PWC1 enunciator and output control will be turned on for the *CT ON* time.
7. If *G SEQ=2* (A->B), then PWC2 enunciator and output control will stay on until the weight reaches the *SLOW-TRIM* weight.
8. If *G SEQ=3* (Chatter-gate), then the PWC1 enunciator and output will pulse on and off until the weight reaches the *SLOW-TRIM* weight.
9. If the fill control parameters were retrieved from memory, then the filled weight will be added to the accumulator and the count will be incremented, and saved to the ID.
10. When all motion stops, the weight will be printed (if a printer is attached and *RPRINT=YES*). The following is an example of the information printed.

14:54 12/13/2012
#53
12000 lb G
00 lb T
12000 lb N

11. If *ATRIM=YES* was selected in setup, the trim weight will be recalculated and stored in memory and the displayed weight value added to the PRESET and GROSS or NET accumulators.
12. If *DGATE=YES* and *ADISC=YES* were selected in setup, then the completed fill operation will immediately begin to discharge and PWC3 enunciator and output control are turned on. The weight display will change from net to gross. The discharge will continue until the scale weight returns to zero within the *D TOL=XX* value.
13. If *DGATE=YES* and *ADISC=NO* were selected in setup, then the completed fill operation will wait for the **F** key or the optional **START** pushbutton to be pressed for the discharge to begin (PWC3 enunciator and output control are turned on). The weight display will change from net to gross. The discharge will continue until the scale weight returns to zero within the *D TOL=XX* value.

To Suspend (Pause) or Stop (Abort) a Fill Operation in Progress

The fill operation can be suspended (paused) or stopped (aborted) by the operator if needed.

1. To pause the filling operation, press the **F** key or press the optional **START** pushbutton.
2. The fill operation will be suspended (paused) and the *PAUSED* message will flash on the display.
3. To continue the fill operation, press the **F** key. If the optional **START** pushbutton is pressed go to step 7.
4. The *CONT ?* prompt will be displayed, press the **ENTER** key, the *NO* prompt will be displayed.
5. To stop (abort) the fill operation, press the **ENTER** key.
6. To continue the fill, press the **1/YES** key or the optional **START** pushbutton.
7. The 212G/212GX will return to normal operation, displaying the Gross weight on the scale.

NOTE: If *DGATE=YES*, the fill operation cannot be restarted after a STOP if the material weight is above the zero tolerance.

NOTE: If the optional **STOP** pushbutton is pressed, the fill operation will immediately be aborted.

DIGITAL FILL CONTROL ID STORAGE

If the setup parameter *STOR=YES*, then up to 25 DFC-ID filling settings can be saved.

To Add a DFC-ID Setting

1. With the indicator in normal operations mode, press the * key. The display will change *FUNC=*, press the **PRESET** key.
2. Enter up to a 6-digit alphanumeric ID string and press the **ENTER** key.

3. SINGLE SPEED:

The display will show *FILL=*, press the **ENTER** key. A 0 *FILL* weight will be displayed, if the displayed weight is acceptable press the **ENTER** key, otherwise, use the numeric keys to enter the new *FILL* weight and press **ENTER**.

TWO SPEED:

The display will show *FAST=*, press the **ENTER** key. A zero *FAST* weight will be displayed, if the displayed weight is acceptable press the **ENTER** key, otherwise, use the numeric keys to enter the new *FAST* weight and press **ENTER**.

4. SINGLE SPEED:

Skip to step 5.

TWO SPEED:

The display will change to *SLOW=*, press the **ENTER** key. A zero *SLOW* weight will be displayed, if the displayed weight is acceptable press the **ENTER** key, otherwise, use the numeric keys to enter the new *SLOW* weight and press **ENTER**.

NOTE: The *SLOW* weight **MUST** be greater than the *FAST* weight.

5. The display will change to show *TRIM=*, press the **ENTER** key and the current trim weight will be displayed. If this value is acceptable press the **ENTER** key, otherwise, use the numeric keys to enter a new trim weight and press the **ENTER** key.
6. The display will change to *ACCUM=*, press the **ENTER** key to show a zero value for the accumulator associated with this ID.
7. If a zero value is correct, press the **ENTER** key to save it. Otherwise, using the numeric keys enter the accumulator value and then press the **ENTER** key to save it.
8. The display will change to *COUNT=*, press the **ENTER** key to show a zero value for the number of batches associated with this ID.
9. If a zero value is correct, press the **ENTER** key to save it. Otherwise, using the numeric keys enter the number of batches and then press the **ENTER** key to save it.
10. The indicator will return to normal operation.

To Edit or View A DFC-ID Setting

1. With the indicator in normal operations mode, press the * key. The display will change *FUNC* =, press the **PRESET** key.

2. Enter up to a 6-digit alphanumeric ID string and press the **ENTER** key.

3. SINGLE SPEED:

The display will show *FILL* =, press the **ENTER** key. The current *FILL* weight will be displayed, if the displayed weight is acceptable press the **ENTER** key, otherwise, use the numeric keys to enter the new *FILL* weight and press **ENTER**.

TWO SPEED:

The display will show *FAST* =, press the **ENTER** key. The current *FAST* weight will be displayed, if the displayed weight is acceptable press the **ENTER** key, otherwise, use the numeric keys to enter the new *FAST* weight and press **ENTER**.

4. SINGLE SPEED:

Skip to step 5.

TWO SPEED:

The display will change to *SLOW* =, press the **ENTER** key. The current *SLOW* weight will be displayed, if the displayed weight is acceptable press the **ENTER** key, otherwise, use the numeric keys to enter the new *SLOW* weight and press **ENTER**.

NOTE: The *SLOW* weight **MUST** be greater than the *FAST* weight.

5. The display will change to show *TRIM* =, press the **ENTER** key and the current trim weight will be displayed. If this value is acceptable press the **ENTER** key, otherwise, use the numeric keys to enter a new trim weight and press the **ENTER** key.

6. The display will change to *ACCUM* =, press the **ENTER** key to show the current accumulator weight associated with this ID.

7. If the accumulator weight is correct, press the **ENTER** key to save it. Otherwise, using the numeric keys enter the new accumulator value and then press the **ENTER** key to save it.

8. The display will change to *COUNT* =, press the **ENTER** key to show the current count of batches associated with this ID.

9. If the count is correct, press the **ENTER** key to save it. Otherwise, using the numeric keys to enter a new count value and then press the **ENTER** key to save it.

10. The indicator will return to normal operation.

To Delete A DFC-ID Setting

1. With the indicator in normal operations mode, press the * key. The display will change *FUNCT=*, press the **PRESET** key.
2. Enter up to a 6-digit alphanumeric ID string and press the **F** key.
3. The *DEL ID* prompt will be displayed. To delete the ID press the **1/YES** key. The ID will be deleted.
NOTE: To abort the delete operation, press the **0/NO** key.
4. If the entered ID does not exist, the *NOTFND* message will be displayed.

To Print A DFC-ID Setting

1. With the indicator in normal operations mode, press the * key. The display will change *FUNCT=*, press the **PRESET** key.
2. Enter up to a 6-digit alphanumeric ID string and press the **PRINT** key.
3. The *PRT ID* prompt will be displayed, to print the ID press the **1/YES** key. The ID will be printed.
NOTE: To abort the print operation, press the **0/NO** key.
4. If the entered ID does not exist, the *NOTFND* message will be displayed.

To Delete All DFC-ID Setting

1. With the indicator in normal operations mode, press the * key. The display will change *FUNCT=*, press the **PRESET** key.
2. At the *ID=* prompt, press the **F** key.
3. The *DELALL* prompt will be displayed, to delete all of the IDs press the **1/YES** key. The IDs and their associated settings will be deleted.
NOTE: To abort the print operation, press the **0/NO** key.
4. The indicator will return to normal operation.

To Print All DFC-ID Setting

1. With the indicator in normal operations mode, press the * key. The display will change *FUNCT=*, press the **PRESET** key.
2. At the *ID=* prompt, press the **PRINT** key.
3. The *PRTALL* prompt will be displayed, to print all of the IDs press the **1/YES** key. The IDs and their associated settings will be printed.
NOTE: To abort the print operation, press the **0/NO** key.
4. The indicator will return to normal operation.

AXLE WEIGHER MODE OPERATION

After placing the wheel load weighers on the ground in front of the vehicle(s) to be weighed, the two weighers are connected together using the interconnection cable assembly. One weigher (makes no difference which) is connected to the indicator using the indicator interface cable. The interconnection diagram is shown below:

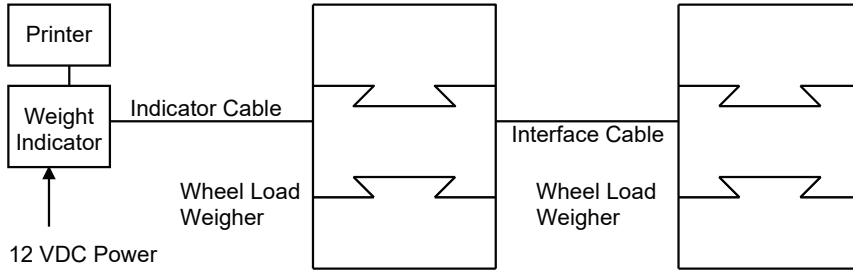

1. With power applied to the indicator, press the **ON** key to turn on the indicator.
2. Verify that the weight display is at zero (*00*). If not, press the **ZERO** key.
3. Have the vehicle driven forward until the first axle is on the center of the wheel load weighers.
4. Observe the weight of the first axle and press the **PRINT** key to record the weight, date and time.
5. Have the vehicle pull forward until the next axle is on the center of the wheel load weighers. **NOTE:** If the next axle is a tandem or tridem set of axles, place **ONLY** the first axle of the group on the wheel load weighers.
6. Observe the weight of this axle and press the **PRINT** key to record the weight, date and time.
7. Repeat step 5 until all of the remaining axles have been weighed and printed.
8. After the last axle has been weighed and its value recorded, pull the vehicle off the wheel load weighers.
9. Press the * (asterisk) key and then press the **PRINT** key. The total of all of the vehicle axle weights will be recorded and printed. The example below illustrates a typical print ticket for a five-axle truck.

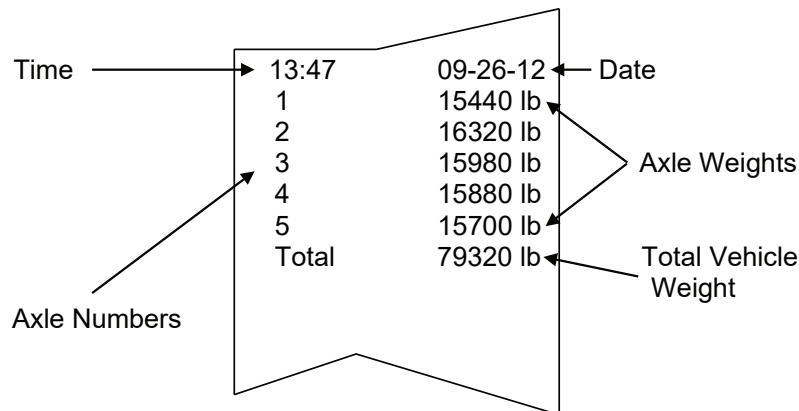

Additional Features

If you wish to also record the total of any axle groups, press the number key corresponding to the number of axles in the axle group to be totaled when the first axle in the group is weighed. After the last axle in the group is recorded, the printer will automatically record the subtotal of the axle group weights. In the previous example, assume that axles 2 and 3 form a tandem pair of axles as do axles 4 and 5. To record the total weight of these axle groups, press the number 2 key followed by the **PRINT** key when printing axles 2 and 4. This indicates that the next two axles form an axle group whose total is to be recorded. The example below illustrates the print format when the two axle groups are identified.

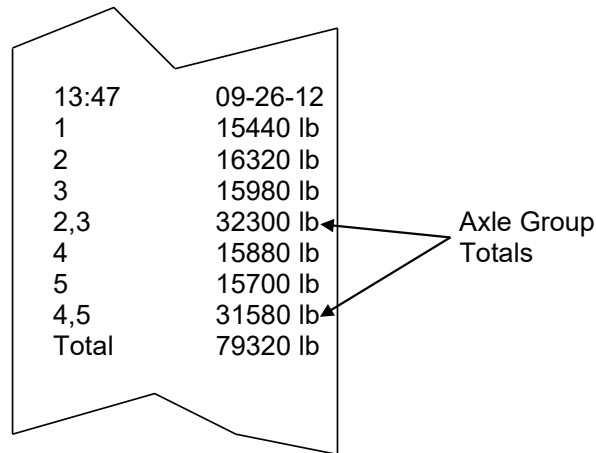

13:47	09-26-12
1	15440 lb
2	16320 lb
3	15980 lb
2,3	32300 lb
4	15880 lb
5	15700 lb
4,5	31580 lb
Total	79320 lb

Note that there is a maximum of 9 single axles in an axle group and that the axles must be weighed in a consecutive group. The axles comprising the axle group are also identified on the printed record.

If you wish to print additional copies of the printed record for the vehicle, press the * (asterisk) key again followed by the **PRINT** key and a summary print will be produced. This can be repeated as often as necessary to secure the number of desired copies. Note, however, that as soon as the first axle of the next vehicle is printed, the weights from the previously weighed vehicle are cleared.

LIVESTOCK WEIGHER MODE OPERATION

To weigh a single animal:

1. Direct animal onto scale.
2. Press the **PRINT** key after scale weight has stabilized.
3. If you have ID printing enabled (*ID=YES*), you will be prompted to enter an ID associated with this ticket. Enter your desired alphanumeric ID, then press **ENTER** key.
4. The ticket will print, and the remote display(s) will lock onto the printed weight while animal remains on the scale.
5. Remove animal from scale and repeat for additional animals.

To weigh many animals on a single ticket:

1. Direct all animals onto scale.
2. Press the **F** key.
3. The indicator will prompt for a head count (*COUNT=*). Enter the number of animals being weighed.
4. Press **ENTER** if still loading animals onto scale, and the head count will be retained for the next print (or if all animals are loaded press the **PRINT** key to immediately print the ticket; Skip next step).

NOTE: The head count value will be cleared after each ticket printed.

5. Press the **PRINT** key to print the ticket.
6. If you have ID printing is enabled (*ID=YES*), you will be prompted to enter an ID associated with this ticket. Enter your desired alphanumeric ID, then press **ENTER** key.
7. The ticket will print, and the remote display(s) will lock onto the printed weight while animals remain on the scale.
8. Remove animals from scale and repeat for additional animals.

The indicator will automatically keep a running total of animal data printed.

To print the totals of consecutive tickets:

1. Press the ***** key.
2. The indicator will display *FUNCT=*.
3. Press the **PRINT** key.
4. Total ticket will be printed containing total weight, total head count, and average weight.
5. These values will be reset after the total ticket is printed.

LOCAL/REMOTE SETUP

If the indicator is to function as a remote indicator, at the *SERSEL* (REMOTE INDICATOR SETUP) prompt, press the ***/UP ARROW** key to select **YES** and then press the **TARE/ENTER** key.

With *SERSEL* set to YES, the *LRP:* (Local/Remote Port) will be displayed to select the serial port for the LOCAL/REMOTE communications.

With the *LRP:* (Local/Remote Port) displayed, press the **TARE/ENTER** key to show the current setting. If the setting displayed is acceptable, press the **TARE/ENTER** key again to save it. Otherwise, use the ***/UP ARROW** key to toggle to a new setting and then press the **TARE/ENTER** key to save it. Allowable values are: 0, 1, 2 or 3 (for port 0 through port 3) and 4 for the optional 2xx-RS232 card (if installed).

Any unused RS-232 serial port may be used (see Figure 20 for port 1 interconnect wiring) for distances less than 100 feet.

NOTE: If the distance between the local and remote indicator is greater than 100 feet, the serial port with a 20mA Current Loop receiver and transmitter, port 1, must be used (see Figure 21 for interconnect wiring).



IMPORTANT! The selected serial port (*SERP*) for the remote indicator must be configured the same as the serial port used for the local indicator. In addition, the Continuous Output must be set to NO (*Cont=NO*).

Local/Remote 210 RS-232 Wiring

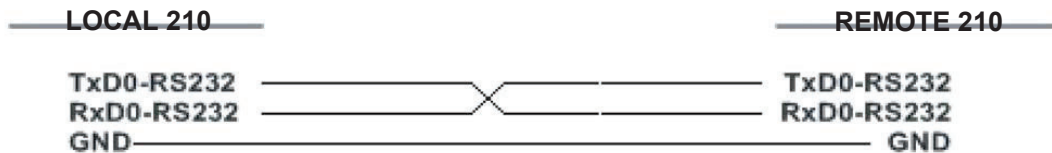
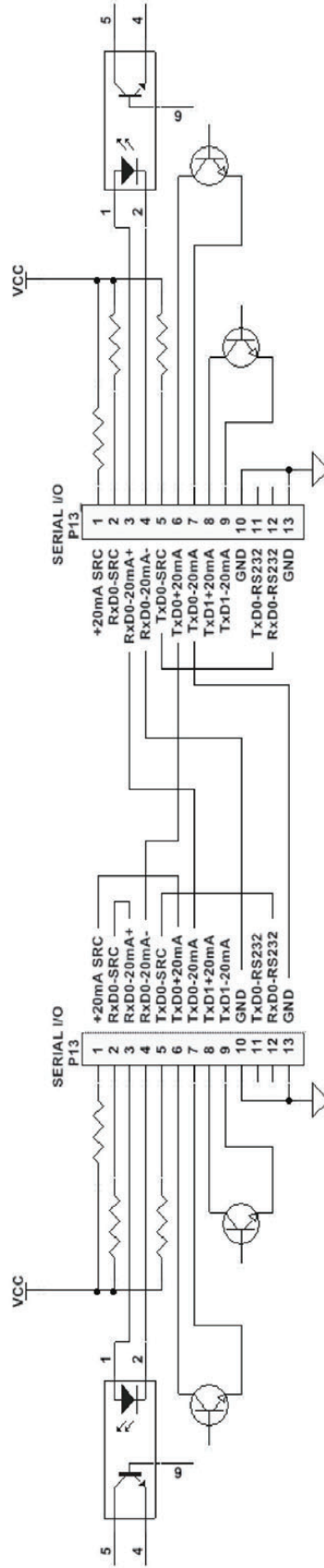

Figure No. 20

Local/Remote 210 20mA Current Loop Wiring

REMOTE 210 PASSIVE



LOCAL 210 ACTIVE

Figure No. 21

PART IDENTIFICATION

Rear Sub-Assembly

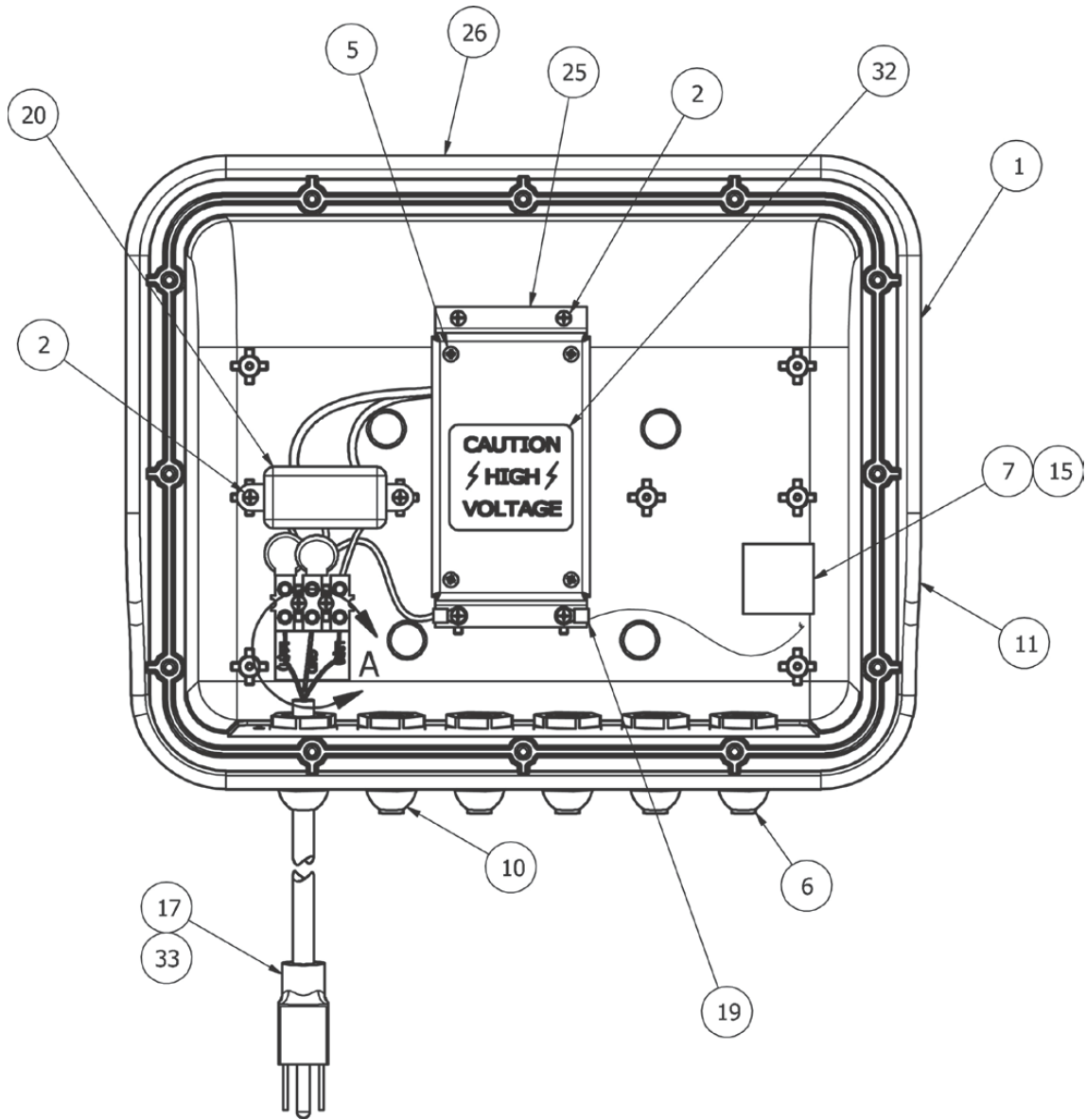

PART IDENTIFICATION

Rear Sub-Assembly

Item	Qty	Part Number	Description
1	1	593GR986	SERIAL TAG ASSY
2	6	6021-1286	SCW PAN-HEAD THREAD CUT TYPE 25, #4X1/4, PHIL. DR. Z/P
5	4	6021-2018	SCW PAN-HEAD.. MACHINE-SCW 04-40X.875
6	5	6540-1104	PLUG, HOLE 0.343" X 0.187" X 1" LG, SILICONE RUBBER
7	1	6560-0064	DESSICCANT, 1"X1" BAG, FOR VOL. UP TO 1 CU.FT
10	6	6610-2248	CONN GLAND .187-.312 GRIP .599 MTG BLK
11	1	6650-0087	LABEL, MADE IN USA (WITH FLAG) 1" X 1"
15	3/4"	6710-1017	TAPE DBL SIDED 1.0" WIDE 45 MIL THICK
17	1	6980-1030	POWER CORD 18/3 SVT CEE 6.3 FT (212G/212GX)
19	1	8200-B212-0A	CABLE: GROUND 205/210
20	1	8200-B237-0A	CABLE: AC POWER W/FILTER 205/210 DWI
25	1	8200-C615-08	POWER SUPPLY COVER
26	1	8200-D608-18	PLASTIC ENCLOSURE, 212G
32	1	8510-C346-0I	LABEL CAUTION HIGH VOLTAGE
33	1	6980-0525	POWER CORD H05VV-F3G 1mm, 10A/250V, BLACK (212GEU/212GXEU)

PART IDENTIFICATION

Front Sub-Assembly

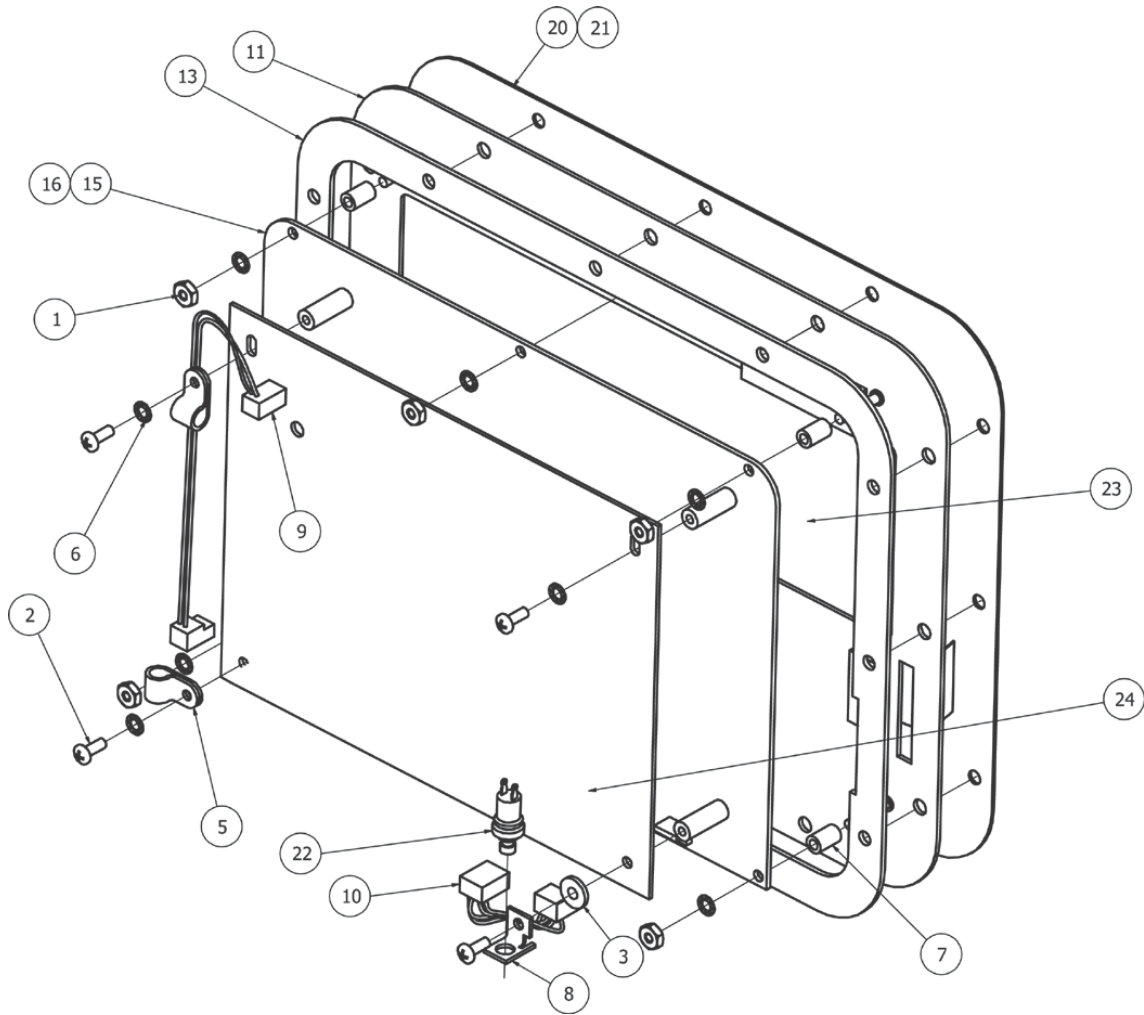

PART IDENTIFICATION

Front Sub-Assembly

Item	Qty	Part Number	Description
1	6	6013-0039	NUT #6-32 HEX
2	4	6021-0665	SCW PAN-HEAD.. MACHINE SCW 06-32X.375
3	1	6024-0126	WASHER FLAT FOR 5/32 POP RIVET
5	2	6610-1660	CABLE CLAMP 1/4" DIA #6 SCREW
6	9	6680-0004	WASHER LOCK INT TOOTH #6 TYPE A Z-PL
7	6	6680-0131	SPACER #6 X .400 NYLON
8	1	8200-B276-08	BRACKET, CONNECTOR – WIPOPT INTERFACEE BD
9	1	8200-B605-0A	CABLE: POWER, 212 TO 210
10	1	8200-B614-0A	CABLE: IIC 2.5"
11	1	8200-C609-0A	FRONT PLATE WELDMENT
13	1	8200-C618-08	GASKET, 212
15	1	8200-D600-0A	PCB: DISPLAY, 212/212G
16	1	8200-D600-1A	PCB: DISPLAY, 212X/212GX
20	1	8200-D619-08	KEYPAD: 212GX DWI
21	1	8200-D620-08	KEYPAD: 212G DWI
22	1	8555-B053-0A	CABLE ASSEMBLY: CAL SWITCH
23	1	6670-0019	FILTER, RFI, WIRE MESH, 3.4" X 9.2"
24	1	8200-D124-1A	PCB ASSEMBLY – 210 CONTROLLER

PART IDENTIFICATION

Final Assembly

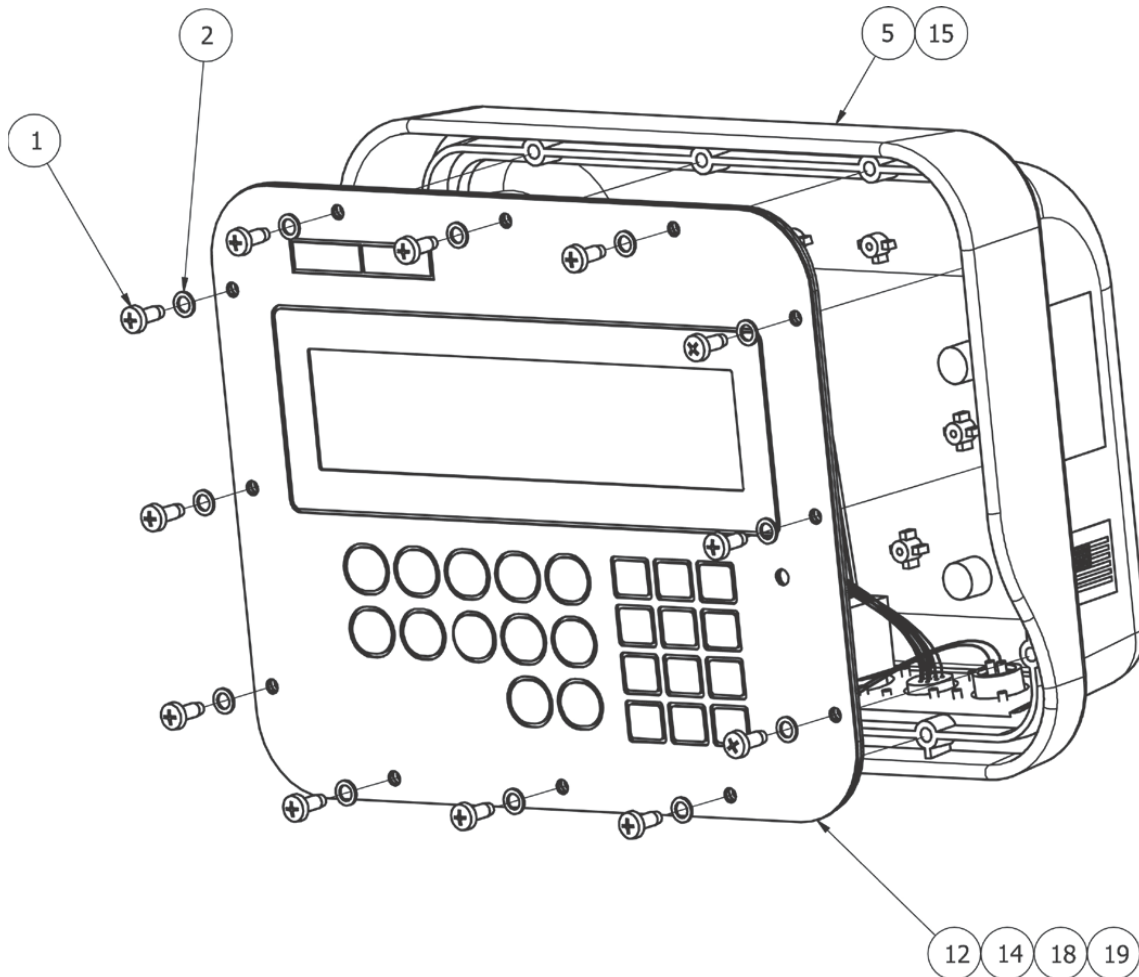

Item	Qty	Part Number	Description
1	12	6021-1289	SCW PAN-HEAD PLASTIC THD. ROLLING, #10X1/2, PHIL. DR. Z/P
2	12	6024-0141	WASHER FLAT 0.345 OD, 0.218 ID, 0.032 THK NYLON
5	1	8200-D629-1A	REAR SUB-ASSEMBLY: 212G
12	1	8200-D630-2A	FRONT SUB-ASSEMBLY: 212G
14	1	8200-D630-4A	FRONT SUB-ASSEMBLY: 212GX
15	1	8200-D629-6A	REAR SUB-ASSEMBLY: 212GEU/212GXEU
18	1	8200-D630-7A	FRONT SUB-ASSEMBLY: 212GEU
19	1	8200-D630-8A	FRONT SUB-ASSEMBLY: 212GXEU

STATEMENT OF LIMITED WARRANTY

WARRANTY TERMS

Cardinal Scale Manufacturing Company warrants the equipment we manufacture against defects in material and workmanship. The length and terms and conditions of these warranties vary with the type of product and are summarized below:

PRODUCT TYPE	TERM	MATERIAL AND WORKMANSHIP	LIGHTNING DAMAGE See note 9	WATER DAMAGE See note 7	CORROSION See note 4	ON-SITE LABOR	LIMITATIONS AND REQUIREMENTS
WEIGHT INDICATORS	90 DAY REPLACEMENT ----- 1 YEAR PARTS	YES	YES	YES	YES	NO	1, 2, 3, 5, 6 A, B, C, D
LOAD CELLS (Excluding Hydraulic)	1 YEAR	YES	YES	YES	YES	NO	1, 2, 3, 5, 6 A, B, C, D
HYDRAULIC LOAD CELLS (When purchased with Guardian Vehicle Scale)	LIFETIME	YES	YES	YES	YES	90 DAYS	1, 5, 6, 8 A, B, C, D
HYDRAULIC LOAD CELLS (When purchased separately)	10 YEARS	YES	YES	YES	YES	NO	1, 5, 6, 8, 9 A, B, C, D
VEHICLE SCALE (Deck and Below Excl. PSC Series)	5 YEARS	YES	YES	YES	YES	90 DAYS	1, 2, 3, 5, 6 A, B, C, D, E
LSC SCALE (Deck and Below)	3 YEARS	YES	YES	YES	YES	90 DAYS	1, 2, 3, 5, 6, 11 A, B, C, D
GUARDIAN FLOOR SCALES	10 YEARS	YES	YES	YES	YES	NO	1, 2, 3, 5, 6, 9, 10 A, B, C, D
ALL OTHER CARDINAL PRODUCTS	1 YEAR	YES	YES	YES	YES	NO	1, 2, 5, 6 A, B, C, D, E
REPLACEMENT PARTS	90 DAYS	YES	YES	YES	YES	NO	1, 2, 4, 5, 6 A, B, C, D
SWIM AND 760 SERIES VEHICLE SCALES	1 YEAR	YES	YES	YES	YES	90 DAYS	1, 2, 5, 6 A, B, C, D
SOFTWARE	90 DAYS	YES	N/A	N/A	N/A	NO	1, 6 B, C, D
CONVEYOR BELT SCALES (including Belt-Way)	1 YEAR	YES	YES	YES	YES	NO	1, 2, 3, 5, 6 A, B, C, D, E, F



CARDINAL

Ph. (800) 441-4237
E-mail: cardinal@cardet.com
102 E. Daugherty
Webb City, MO 64870

04/24
Printed in USA
315-WARRANTY-CAR-M

APPLICABLE LIMITATIONS AND REQUIREMENTS

1. This warranty applies only to the original purchaser. The warranty does not apply to equipment that has been tampered with, defaced, damaged, or had repairs or modifications not authorized by Cardinal or has had the serial number altered, defaced or removed.
2. This warranty is not applicable to equipment that has not been grounded in accordance with Cardinal's recommendations.
3. This equipment must be installed and continuously maintained by an authorized Cardinal / Belt-Way dealer.
4. Applies only to components constructed from stainless steel.
5. This warranty does not apply to equipment damaged in transit. Claims for such damage must be made with the responsible freight carrier in accordance with freight carrier regulations.
6. Warranty term begins with date of shipment from Cardinal.
7. Only if device is rated NEMA 4 or better or IP equivalent.
8. Lifetime warranty applies to damages resulting from water, lightning, and voltage transients and applies only to the hydraulic load cell structure itself (does not include pressure transducers, rubber seals, o-rings, and associated wiring).
9. 10-Year prorated warranty on hydraulic load cells.
10. 1-Year warranty for scale structure.
11. PSC models' warranty coverage applies only to agricultural installations on farms up to 3,000 acres (LSC models not limited in this manner).
12. Load cell kits MUST be installed in accordance with Cardinal Scale instructions. Failure to follow these instructions will void the warranty.

EXCLUSIONS

- A.) This warranty does not include replacement of consumable or expendable parts. The warranty does not apply to any item that has been damaged due to unusual wear, abuse, improper line voltage, overloading, theft, fire, water, prolonged storage or exposure while in purchaser's possession or acts of God unless otherwise stated herein.
- B.) This warranty does not apply to peripheral equipment not manufactured by Cardinal. This equipment will normally be covered by the equipment manufacturer's warranty.
- C.) This warranty sets forth the extent of our liability for breach of any warranty or deficiency in connection with the sale or use of our product. Cardinal will not be liable for consequential damages of any nature, including but not limited to loss of profit, delays or expenses, whether based on tort or contract. Cardinal reserves the right to incorporate improvements in material and design without notice and is not obligated to incorporate said improvements in equipment previously manufactured.
- D.) This warranty is in lieu of all other warranties expressed or implied including any warranty that extends beyond the description of the product including any warranty of merchantability or fitness for a particular purpose. This warranty covers only those Cardinal products installed in the forty-eight contiguous United States and Canada.
- E.) This warranty does not cover paint coatings due to the variety of environmental conditions.
- F.) Do not cut load cell cables on load cells returned for credit or warranty replacement. Cutting the cable will void the warranty.
- G.) Software is warranted only for performance of the functions listed in the software manual and/or the Cardinal proposal.
- H.) The software warranty does not cover hardware. Warranties on hardware are provided from the hardware vendor only.
- I.) The software warranty does not cover interfacing issues to non-Cardinal supplied hardware.
- J.) The software warranty does not include automatic software upgrades unless purchased separately.



Ph. (800) 441-4237
E-mail: cardinal@cardet.com
102 E. Daugherty
Webb City, MO 64870

04/24
Printed in USA
315-WARRANTY-CAR-M

Cardinal Scale Mfg. Co.

102 E. Daugherty, Webb City, MO 64870 USA

Ph: 417-673-4631 or 1-800-641-2008

Fax: 417-673-2153

www.cardinalscale.com

Technical Support: 1-866-254-8261

E-mail: tech@cardet.com

Printed in USA

8200-M694-O1 Rev B 05/13