



CARDINAL®



Model 190 Indicator Installation, Technical, and Operation Manual

Includes Models 190A, 190-BP, 190DC, 190EU, 190LS, 190UK, and options BP190, 190-DAC, 190-IP, 190-RS232, 190-USB, and 190-WIFI

INTRODUCTION

Thank you for selecting and purchasing the Cardinal Model 190 Weight Indicator. The Model 190 indicator was built with quality and reliability and incorporates the latest in digital technology and innovative features for the weighing industry. Configuration and upgrades can easily be performed in the field, while still maintaining the rigid control the most demanding installations require. This flexibility ensures the Model 190 will be able to meet your weight indicating needs for years to come.

The purpose of this manual is to provide you with a guide through the installation, setup, and operation of your new Model 190 Weight Indicator. Please read it thoroughly before attempting to install your indicator and keep it available for future reference

COPYRIGHT

All rights reserved. Reproduction or use, without expressed written permission, of editorial or pictorial content, in any manner, is prohibited. No patent liability is assumed with respect to the use of the information contained herein.

DISCLAIMER

While every precaution has been taken in the preparation of this manual, the Seller assumes no responsibility for errors or omissions. Neither is any liability assumed for damages resulting from the use of the information contained herein. All instructions and diagrams have been checked for accuracy and ease of application; however, success and safety in working with tools depend to a great extent upon individual accuracy, skill, and caution. For this reason, the Seller is not able to guarantee the result of any procedure contained herein. Nor can they assume responsibility for any damage to property or injury to persons occasioned from the procedures. Persons engaging in the procedures do so entirely at their own risk.

PRECAUTIONS

Before using this indicator, read this manual and pay special attention to all “NOTIFICATION” symbols:



**ELECTRICAL
IMPORTANT**

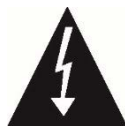

**STATIC
WARNING**



SENSITIVE

FCC COMPLIANCE STATEMENT

This equipment generates uses and can radiate radio frequency and if not installed and used in accordance with the instruction manual, may cause interference to radio communications. It has been tested and found to comply with the limits for a Class A computing device pursuant to Subpart J of Part 15 of FCC rules, which are designed to provide reasonable protection against such interference when operated in a commercial environment. Operation of this equipment in a residential area may cause interference in which case the user will be responsible to take whatever measures necessary to correct the interference.

You may find the booklet “How to Identify and Resolve Radio-TV Interference Problems” prepared by the Federal Communications Commission helpful. It is available from the U.S. Government Printing Office, Washington, D.C. 20402. Stock No. 001-000-00315-4.

PROPER DISPOSAL

When this device reaches the end of its useful life, it must be properly disposed of. It must not be disposed of as unsorted municipal waste. Within the European Union, this device should be returned to the distributor from where it was purchased for proper disposal. This is in accordance with EU Directive 2002/96/EC. Within North America, the device should be disposed of in accordance with the local laws regarding the disposal of waste electrical and electronic equipment.

It is everyone’s responsibility to help maintain the environment and to reduce the effects of hazardous substances contained in electrical and electronic equipment on human health. Please do your part by making certain that this device is properly disposed of. The symbol shown to the right indicates that this device must not be disposed of in unsorted municipal waste programs.



TABLE OF CONTENTS

PRECAUTIONS	I
SPECIFICATIONS	1
Standard Features	2
Optional Features	2
European Declaration of Conformity	3
PRECAUTIONS	4
Static Electricity.....	4
Batteries.....	4
INSTALLATION	5
Site Preparation Requirements	5
Environmental	5
Electrical Power	6
Electrical Noise Interference	6
Transient Suppression	6
Mounting	7
Load Cell Connections	8
Load Cell Connections with Over 30 Feet of Cable	9
Sense and Dead Load Jumpers.....	9
Serial and I/O Cable Installation.....	10
P3 I/O Connections (Refer to Figure No. 6)	10
P2 Power Connections (Refer to Figure No. 6)	10
P3 I/O Interconnection Diagram.....	11
Re-Installing the Front Panel.....	11
INDICATOR SETUP	12
Calibration Inhibit Jumper	12
Calibration Data Entry	13
Accessing Setup	14
Settings	15
Analog to Digital Filtering	21
Filter Setting Recommendations	23
Calibration.....	24
Dual-Point with Zero (First Zero) Calibration.....	25
Dual-Point without Zero (False Zero) Calibration	26
Single-Point for Span Only (Last Zero) Calibration	27
Single-Point for Zero Only (Only Zero) Calibration.....	28
Multi-Point Calibration	29
Calibration “E” Numbers.....	31

Set Gravity Constant	32
Serial Input/Output.....	33
Print Tab Settings	36
Fine Span Adjustment	39
Display High Resolution Weight	40
Key Lockout Feature	41
Options Setup.....	43
Function Setup	45
Display Backlight Color Setup	47
KEYPAD.....	49
Standard Key Functions	49
Fn/▲ Key Functions	52
Fn/▲ Key Combination Features	53
ANNUNCIATORS.....	54
Battery Status.....	56
INDICATOR SETUP REVIEW.....	57
Accessing Setup Review	57
OPERATION	59
Ticket Format Selection.....	59
Preset Weight Comparators	60
Hold Function	61
Count Function.....	62
Time and Date Functions	63
Peak Hold Function	64
Checkweigher.....	65
Live Weight Function.....	67
Accumulated Weight Function.....	68
Touch Key Lock Out Function	69
ASCII Commands.....	70
ERROR MESSAGES.....	75
Before You Call Service	75
Error Codes	76
EVENT COUNTERS.....	77
Accessing the Event Counters	77
TEST MODE/ DIAGNOSTICS.....	79
Accessing Test Mode/Diagnostics.....	79

PARTS IDENTIFICATION.....	80
Front Sub-Assembly.....	80
Rear Sub-Assembly	82
AC Wiring (Detail C).....	83
Power Supply Sub-Assembly.....	84
P2 Wiring Detail	85
P2 Wiring Detail with 190-DAC Option Card.....	85
190DC and 190LS Rear Sub-Assembly.....	86
190DC Power Supply Sub-Assembly.....	87
190DC Wiring Detail B.....	88
190DC POWER OPTIONS (not shown).....	88
APPENDIX A – BP190 OPTIONAL BATTERY PACK	90
BP190 Contents:.....	90
BP190 Specifications:	90
Installing the BP190	91
APPENDIX B – Model 190A.....	93
Traffic Control	93
Axle Weighing Mode	93
Standard Axle Weighing Operation.....	95
Auto Axle Weighing Operation	97
Wiring.....	98
Scoreboard Interconnections	99
APPENDIX C – 190-RS232 Option.....	100
Operation	100
Specifications.....	100
Onboard Status/Diagnostic LED's.....	100
Serial Option Card P4 Wiring	100
Setup.....	101
APPENDIX D – 190-IP Option	104
Features.....	104
Onboard Status/Diagnostic LED's.....	104
Setup.....	105
Ethernet Cable Installation	106
IP Address Setup	106
190-IP Operation.....	106
XPORT Connector Status LED's	107

APPENDIX E – 190-WiFi Option 108

- Specifications 108
- Onboard Status/Diagnostic LED's 109
- Setup 110
- Network Configuration 112
- Wi-Fi Operation 116

APPENDIX F – 190-DAC Option 117

- Specifications 117
- Onboard Status/Diagnostic LED's 118
- Setup 119
- DAC Wiring 121

APPENDIX G – 190-USB Option 122

- Features 122
- Onboard Status/Diagnostic LED's 122
- Setup 123
- 190-USB Operation 124

SPECIFICATIONS

Power Requirements:	100 to 240V AC (50/60 Hz) at 0.4A Max.
Enclosure Type:	Thermoplastic IP69K wall or desk-mount
Enclosure Size:	9.4" W x 6.4" H x 3.7" D (239mm W x 163mm H x 93mm D)
Operating Environment:	Temperature: 14 to 104 °F (-10 to +40 °C) Humidity: 90% non-condensing (maximum)
Display:	Six-digit, seven segment, 1.0" high Backlit LCD
Transducer Excitation:	5.15V DC
Signal Input Range:	0.5 mV min. to 40 mV max. (with dead load boost)
Number of Load Cells:	6 each, 350 OHM minimum resistance
Load Cell Cable Length:	1500 feet maximum. 30 feet maximum without sense lines Consult factory for other requirements
Division Value:	1, 2, or 5 x 10, 1, 0.1, 0.01, 0.001 commercial 0 to 99, non-commercial
Sensitivity:	
NON-COMMERCIAL	0.15 uV/e
NTEP	0.5uV/e (Class III/IIIL)
CANADA	0.5uV/e (Class III/IIHHD)
Scale Divisions:	
NON-COMMERCIAL	100 to 240,000
NTEP	100 to 10,000 (Class III/IIIL)
CANADA	100 to 10,000 (Class III/IIHHD)
Internal Resolution:	1 part in 16,777,216
Tare Capacity:	Scale Capacity
Sample Rate:	1 to 100 samples per second, selectable
Auto Zero Range:	0.5 or 1 through 9 divisions
Weighing Units:	Pounds, Ounces, Kilograms, Grams
Keypad:	Color-Coded, Capacitive Touch-type, 7 keys
Standard I/O:	(1) bi-directional RS232

Standard Features

- Push-button tare function
- Gross, tare, net conversion
- Selectable key lockout
- Hi-Resolution mode
- StableSENSE^{®1} adjustable digital filtering
- Gross and Net accumulators
- Single serial port
- Remote input line for Zero, Tare, Gross, and Print (1000 feet maximum)
- Programmable print format using Visual Print or nControl (1 Visual Ticket available)
- SMA level 2 compliant serial communications (For more information see <http://www.scalemanufacturers.org>)
- Field re-programmable via PC interconnection
- Test feature (performs display and internal tests)
- Auto Shutoff and Sleep modes
- Battery operation (Requires additional hardware and includes additional documentation)

Optional Features

Additional Serial Port (190-RS232)*, Ethernet TCP/IP (190-IP)*, Wi-Fi Wireless Ethernet TCP/IP (190-WIFI)*, Analog Output (190-DAC)*, Special Filtering, and Column Mounting

*This feature requires additional hardware.

¹ StableSENSE[®] is a digital filter utilizing proprietary software algorithms to remove or greatly reduce changes in the weight display resulting from movement on the scale platform. StableSENSE[®] can be used with livestock and single animal scales to lessen the effects of the animal's movement on the scale or it can be used with vehicle scales to lessen the effects of wind and vehicle vibration. Any application affected by vibration or movement on the scale platform can benefit from using StableSENSE[®].

European Declaration of Conformity

Manufacturer: Cardinal Scale Manufacturing Company
PO Box 151
203 East Daugherty
Webb City, Missouri 64870 USA

Telephone No. 417 673 4631
Fax No. 417 673 5001

Product: Non-automatic Weight Indicating Instrument
Model Numbers 190EU
Serial Number EXXXYY-ZZZ
where XXX = day of year
YY = last two digits of year
ZZZ = sequential number

The undersigned hereby declares, on behalf of Cardinal Scale Manufacturing Company of Webb City, Missouri, that the above-referenced product, to which this declaration relates, is in conformity with the provisions of:

Council Directive 2006/95/EC Low Voltage Directive
Test Report Number 0206-1 Cardinal Scale Mfg. Co.

Council Directive 90/384/EEC (20 June, 1990) on the Harmonization of the Laws of Member States relating to non-automatic Weighing Systems as amended by:
Council Directive 93/68/EEC (22 July, 1993)
Certificate of EU Type Approval Number: DK 0199.299

The Technical Construction File required by this Directive is maintained at the corporate headquarters of Cardinal Scale Manufacturing Company, 203 East Daugherty, Webb City, Missouri.



Mark Levels
Quality Assurance Administrator

PRECAUTIONS

Static Electricity



CAUTION! This device contains static-sensitive circuit cards and components. Improper handling of these devices or printed circuit cards can result in damage to or destruction of the component or card. Such actual and/or consequential damage **IS NOT** covered under warranty and is the responsibility of the device owner. Electronic components must be handled only by qualified electronic technicians who follow the guidelines listed below.



ATTENTION! ALWAYS use a properly grounded wrist strap when handling, removing, or installing electronic circuit cards or components. Make certain that the wrist strap ground lead is securely attached to an adequate ground. If you are uncertain of the quality of the ground, you should consult a licensed electrician.



ALWAYS handle printed circuit card assemblies by the outermost edges. **NEVER** touch the components, component leads, or connectors. **ALWAYS** observe warning labels on static protective bags and packaging and never remove the card or component from the packaging until ready for use. **ALWAYS** store and transport electronic printed circuit cards and components in anti-static protective bags or packaging.

Batteries



CAUTION: RISK OF EXPLOSION IF BATTERY IS REPLACED BY AN INCORRECT TYPE. DISPOSE OF USED BATTERIES ACCORDING TO THE INSTRUCTIONS.

ATTENTION: RISQUE D'EXPLOSION SI LA BATTERIES EST REMPLAC'E PAR UN TYPE INCORRECT. REJETEZ LES BATTERIES UTILISE'ES SELON LES INSTRUCTIONS.

INSTALLATION

Site Preparation Requirements

The Cardinal Model 190 indicator is a precision weight-measuring instrument. As with any precision instrument, it requires an acceptable environment to operate at peak performance and reliability. This section is provided to assist you in obtaining such an environment.

Environmental

The 190 indicator meets or exceeds all certification requirements within a temperature range of 14 to 104 °F (-10 to +40 °C).

To keep cooling requirements to a minimum, the indicator should be placed out of direct sunlight and to provide adequate air circulation, keep the area around the indicator clear.

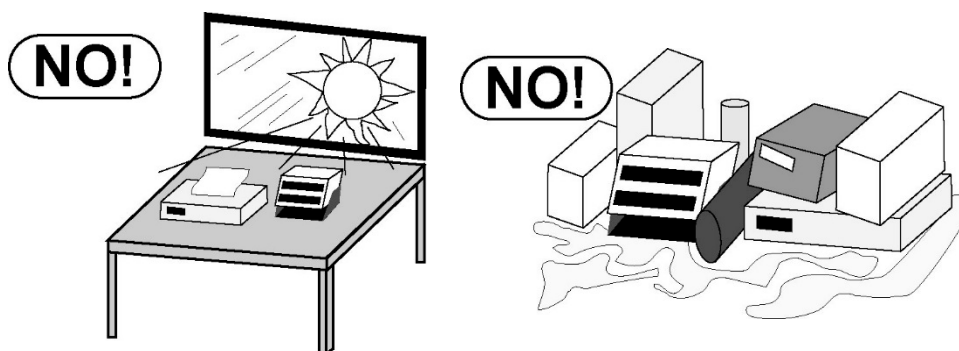

Make certain the indicator is not directly in front of a heating or cooling vent. Such a location will subject the indicator to sudden temperature changes, which may result in unstable weight readings.

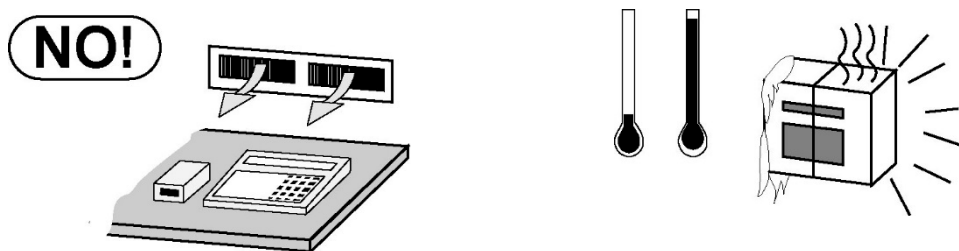

Ensure that the indicator has good, clean AC power and is properly grounded. In areas subject to lightning strikes, additional protection to minimize lightning damage, such as surge suppressors, should be installed.

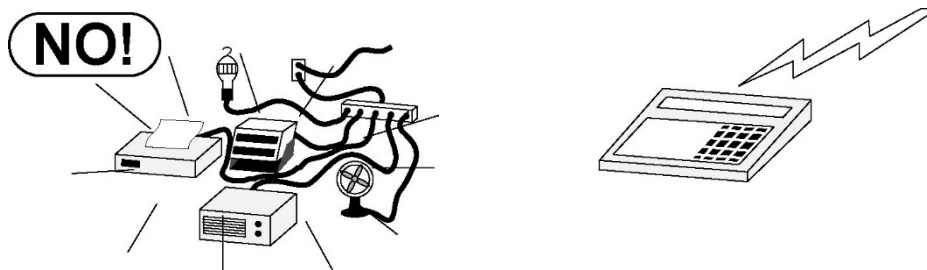

Electrical Power

The 190 has been designed to operate from 100 to 240V AC @ 0.4A Max. at 50/60 Hz. Note that a special order is not required for operation at 230/240V AC.



WARNING! - To avoid electrical hazard and possible damage to the indicator, DO NOT, under any circumstance, cut, remove, alter, or in any way bypass the power cord grounding prong.

The socket-outlet supplying power to the indicator should be on a separate circuit from the distribution panel and dedicated to the exclusive use of the indicator.

The socket outlet shall be installed near the equipment and shall be easily accessible. Note that the power cord on the 190 serves as the power disconnect.

The wiring should conform to national and local electrical codes and ordinances and should be approved by the local inspector to assure compliance.

For outdoor operations, the socket-outlet must provide GFCI (ground fault circuit interrupter) protection.

On installations requiring 230/240V AC power, **it is the responsibility of the customer** to have a qualified electrician install the proper power cord plug that conforms to national electrical codes and local codes and ordinances.

Electrical Noise Interference

To prevent electrical noise interference, make certain all other wall outlets for use with air conditioning and heating equipment, lighting, or other equipment with heavily inductive loads, such as welders, motors, and solenoids are on circuits separate from the indicator. Many of these disturbances originate within the building itself and can seriously affect the operation of the instrument. These sources of disturbances must be identified and steps must be taken to prevent possible adverse effects on the instrument. Examples of available alternatives include isolation transformers, power regulators, uninterruptible power supplies, or simple line filters.

Transient Suppression

The following recommendations will help to reduce transients:

- Always use shielded cables to connect signal wires to the weight indicator.
- Secure the cables in the cable clips provided inside the indicator.
- Connect the cable shield (indicator end only) to a ground point inside the indicator. Keep wires that extend beyond the shield as short as possible.
- Do not run load cell or signal cables from the weight indicator alongside or parallel to wiring carrying AC power. If unavoidable, position the load cell and signal cables a minimum of 24" away from all AC wiring.
- Always use arc suppressors across all AC power relay contacts.
- Use zero voltage switching relays, optically isolated if possible.

Mounting

Before beginning the installation of your Model 190 Indicator, make certain that it has been received in good condition. Carefully remove it from the shipping carton and inspect it for any evidence of damage (such as exterior dents or scratches) that may have taken place during shipment. Keep the carton and packing material for return shipment if it should become necessary. It is the responsibility of the purchaser to file all claims for any damages or loss incurred during transit.

NOTE: Should your Model 190 indicator come already installed on a scale, the following information describing the installation of the indicator does not apply.

The Model 190 indicator is housed in a Thermoplastic IP69K wall or desk-mount enclosure. The gimbal may be mounted on a desktop or other smooth, flat, horizontal surface or may be mounted on a wall. Refer to Figure No. 1 for a layout of wall-mounting bolts.

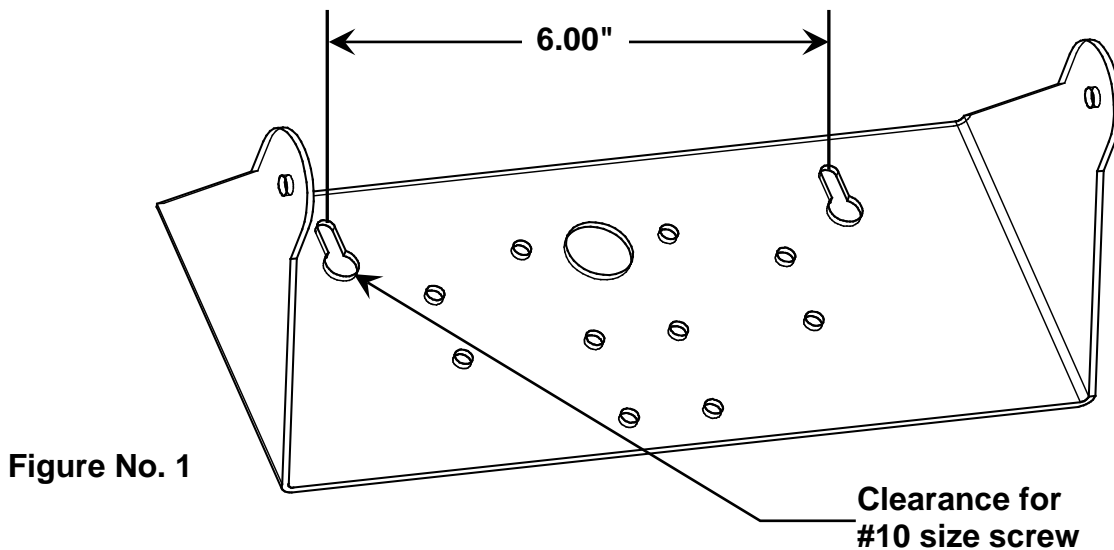

If wall-mounted, make certain the mounting surface is strong enough to support the indicator. The mounting location should be where the display is easily viewed while being close enough to provide the operator easy access to the keypad. Carefully lay out the mounting hole locations, then drill and install the anchor bolts. Attach the gimbal to the wall and securely tighten the retaining bolts.

Load Cell Connections



CAUTION! Disconnect any external load cell power supply before connecting load cells to the indicator. Failure to do so will result in permanent damage to the indicator.

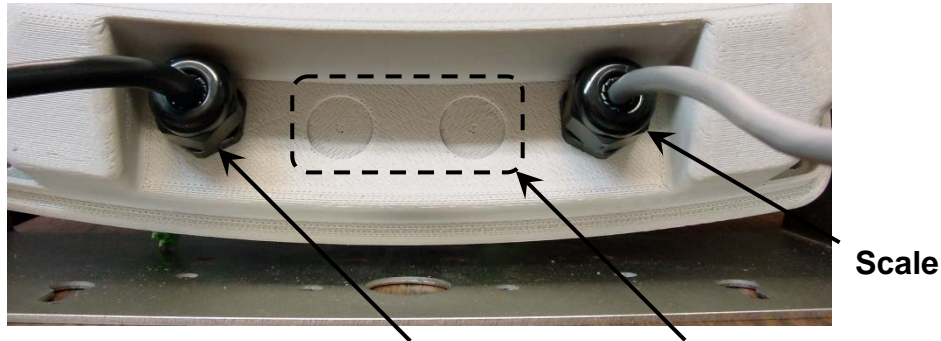

Figure No. 2

AC Power
100-240V AC
0.4 Amp

I/O
(Serial, Isolated
Inputs/Outputs)

1. Loosen the 4 Captive screws securing the rear housing to the front housing assembly.
2. Referring to Figure No. 2, choose a gland connector for the load cell cable and loosen it.
3. Slip the single cable from the load cell or load cell junction box through the gland connector and into the enclosure.

4. Referring to Figure No. 3, remove 3 inches of the outer insulation jacket.
5. Next, remove 1/4 inch of insulation from each of the six wires and shield (with sense leads) or four wires and shield (without sense leads).

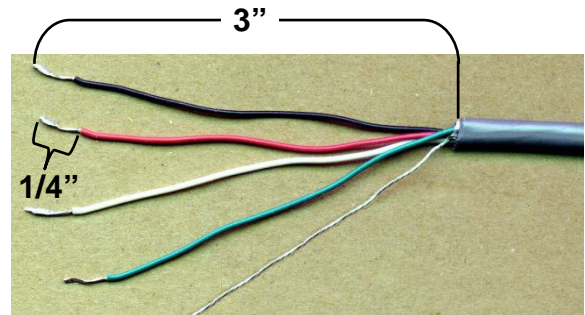

Figure No. 3

6. Remove the 7-connector terminal block connector from P5 on the 190 mainboard. Grasp the terminal block connector and lift straight up away from the board.
7. Referring to the table below and the labels on the circuit board for terminal connections, connect each wire to the terminal block.

P5 Load Cell Wiring Table

P5 Board Label	Function	P5 Board Label	Function
+EXC	+ EXCITATION	-SIG	- SIGNAL
+SEN	+ SENSE	-SEN	- SENSE
+SIG	+ SIGNAL	-EXC	- EXCITATION
SHLD	SHIELD (Connect the load cell cable shield wire here).		

8. To terminate a wire, loosen the screws in the terminal block and then insert the wire into the terminal opening. Tighten the screw to secure the wire in place. See Figure No. 4.

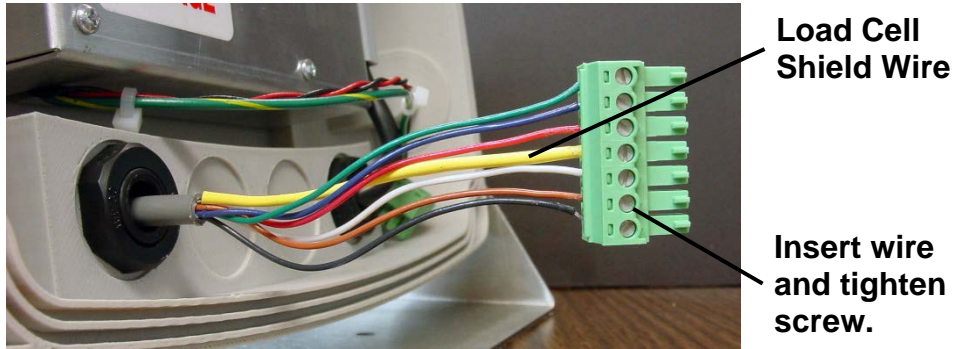

Figure No. 4

9. Repeat the procedure until all wires are in place.

10. After all terminations have been made, remove the excess cable from the enclosure.

Load Cell Connections with Over 30 Feet of Cable

For installations with over 30 feet of cable between the indicator and the load cells, sense wires should be used. The sense wires must be connected between the +SENS, -SENS terminals on the indicator and the +EXCITATION, -EXCITATION wires of the load cells or the +SENS, -SENS terminals of the load cell trim board or the section seal trim board.

Sense and Dead Load Jumpers

J1 (+SEN) and J2 (-SEN) – Sense Jumpers

If the sense leads are NOT used, you must install the +SEN and -SEN jumpers at J1 and J2 (near the P5 terminal block). These jumpers connect the sense leads to the excitation leads. If sense leads ARE used (as in motor truck scales or installations with over 30 feet between the indicator and load cells), these jumpers should be open (on one pin only) or removed.

J3 (DEAD LOAD) – Dead Load Boost Jumper

For scales with very low dead loads (less than 10% of the combined load cell capacity), connect the DEAD LOAD (dead load boost) jumper J3 (near the P5 terminal block).

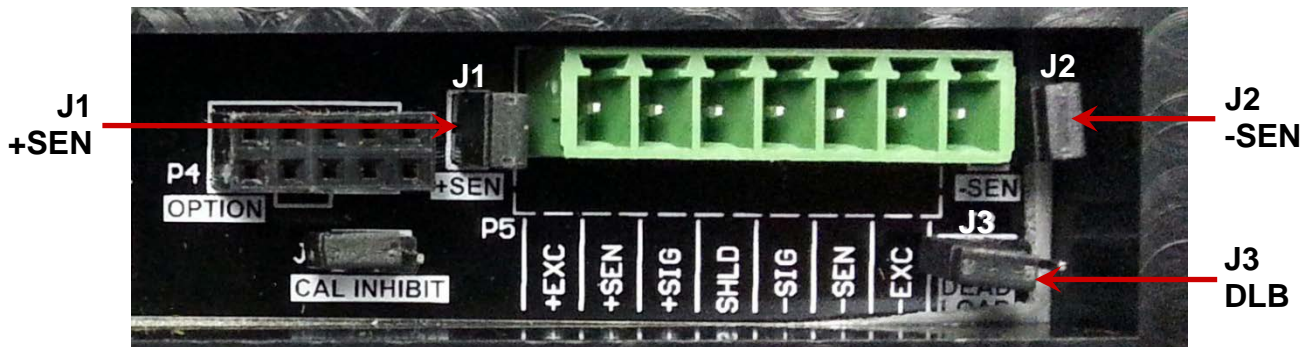

Figure No. 5

Serial and I/O Cable Installation

1. Loosen the 4 Captive screws securing the rear housing to the front housing assembly and then loosen a gland connector for the serial cable. Refer to Figure No. 2 for an illustration of the connector layout.
2. Slip the serial cable through the gland connector and into the enclosure.
3. Remove 3" of the outer insulation jacket then remove 1/4" of insulation from each of the wires (refer to Figure No. 3).
4. Remove the 9-connector terminal block connector from P3 on the 190 mainboard. Grasp the terminal block connector and lift straight up away from the board.
5. Referring to the table below and the labels on the circuit board for terminal connections, connect each wire to the terminal block.
6. To terminate a wire, loosen the screws in the terminal block and then insert the wire into the terminal opening. Tighten the screw to secure the wire in place.
7. Repeat the procedure until all wires are in place.
8. After all terminations have been made, remove the excess cable from the enclosure.

P3 I/O Connections (Refer to Figure No. 6)

SERIAL INTERFACE		INPUT/OUTPUTS	
P3 Board Label	Function	P3 Board Label	Function
TXD	Transmit	IN1	Input 1
RXD	Receive	OUT1	Output 1
GND	Ground	OUT2	Output 2
+9-24 DC	9V DC to 24V DC	OUT3	Output 3
		COMMON	Common

P2 Power Connections (Refer to Figure No. 6)

P2 Board Label	Function
+9V	9V DC
GND	Ground
CHGND	Chassis Ground
+BAT	+ (Plus) Battery
-BAT	- (Negative) Battery

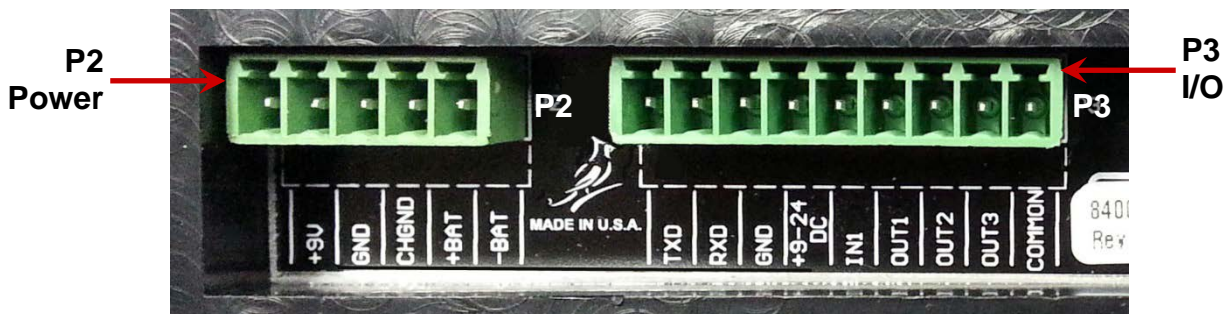

Figure No. 6

P3 I/O Interconnection Diagram

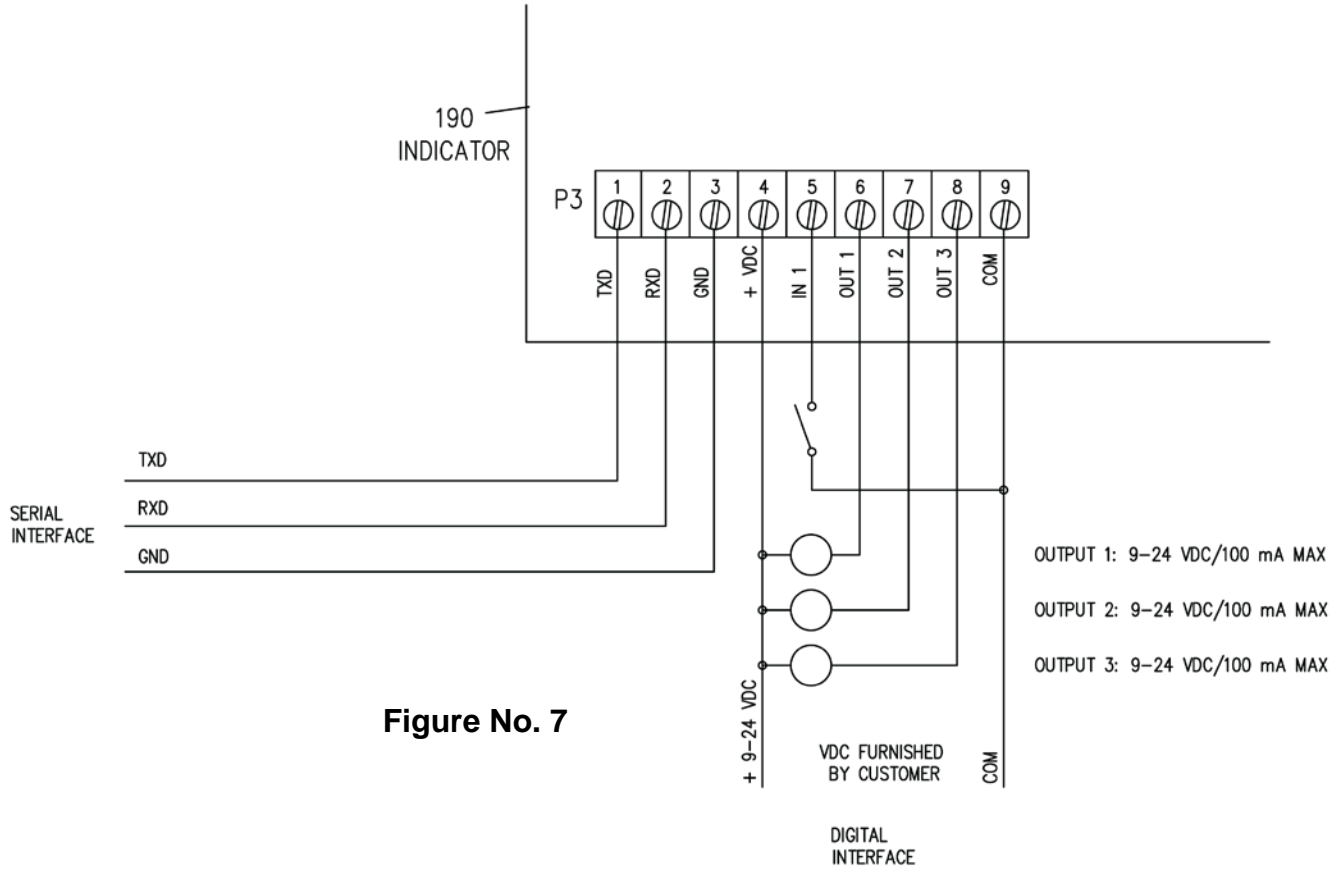

Figure No. 7

Re-Installing the Front Panel

1. After all terminations have been made, remove the excess cable from the indicator enclosure and securely tighten each of the cable gland connectors.
2. Use a wrench to ensure the gland connectors are tight (to maintain a water-tight seal) but do not over-tighten them.
3. Make certain no cables or wires are exposed between the rear housing and front housing assembly and then place the front housing assembly onto the rear housing.
4. Secure by tightening the 4 Captive screws loosened earlier.

INDICATOR SETUP

Calibration Inhibit Jumper

Your Model 190 indicator has been thoroughly tested and calibrated before being shipped to you. If you received the indicator attached to a scale, calibration is not necessary. If the indicator is being connected to a scale for the first time or recalibration is necessary for other reasons, proceed as indicated.

Calibration and Setup of the indicator are accomplished entirely by the keypad. However, it may require changing the position of the calibration inhibit jumper depending on the method of sealing required by your local metrology laws.

The calibration inhibit jumper (**J4**) is located on the main printed circuit board (see Figure No. 8) and can **only** be accessed by removing the front panel of the indicator.

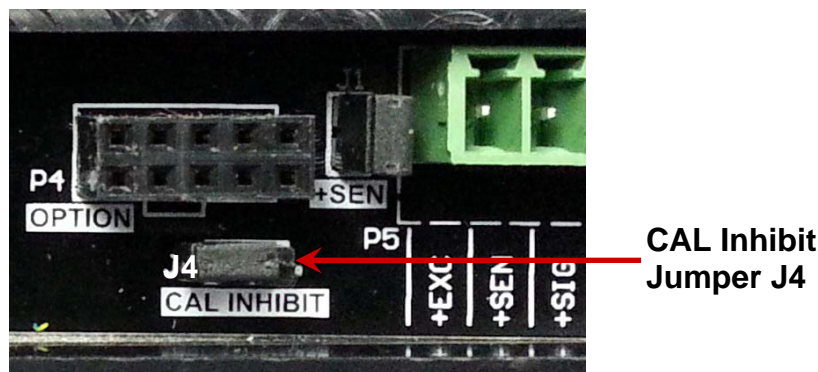

Figure No. 8



IMPORTANT! The following setup parameters **CAN NOT** be changed with the calibration inhibit jumper (**J4**) installed:

<i>USA</i>	=	Domestic or International
<i>Lft</i>	=	Legal-For-Trade
<i>Unit 1</i>	=	Weighing Units 1 (Primary Units)
<i>Int</i>	=	Interval Setting
<i>dPP</i>	=	Decimal Point Precision
<i>CRP</i>	=	Capacity
<i>Unit 2</i>	=	Weighing Units 2 (Secondary Units)
<i>trR</i>	=	Zero Tracking Range
<i>trL</i>	=	4% Zero Limit
<i>PUD</i>	=	Power Up Zero
<i>dFLt</i>	=	Digital Filter Number
<i>F</i>	=	Filter Level Amount
<i>b</i>	=	Filter Break Range
<i>Sr</i>	=	Sample Rate
<i>UnS</i>	=	Motion Range
<i>SC</i>	=	Stable Count

Calibration Data Entry



The Model 190 uses a capacitive touch keypad that requires a “finger touch” to function. The keypad will not operate with other items such as pens, pencils, or tools.



Figure No. 9

During the indicator setup and calibration process, it will be necessary to enter operational parameters via the 190 keypad.

- Pressing the **TARE** \leftarrow key will cause the data entered or displayed to be retained and the 190 to advance to the next prompt.
- The functions of numeric keys are replaced by using the **UNITS**/ \blacktriangleleft and the **Fn**/ \blacktriangle keys.
- The cursor location is identified by the blinking character and can be advanced to the left to the next position by pressing the **UNITS**/ \blacktriangleleft key.
- Pressing the **Fn**/ \blacktriangle key will change the blinking character to the next value or setting. Continue to press this key to "toggle" between the different available values or settings for the setup parameter.
- Pressing the **Fn**/ \blacktriangle key when a setup parameter (not a parameter value or setting) is displayed, will "backup" to the previous parameter prompt.

Accessing Setup

1. With the 190 turned ON, press the **Fn/▲** and **UNITS/◀** key simultaneously.
2. Hold both keys until the display changes to *SEtUP*.
3. Release the keys to begin setup.
4. Press the **UNITS/◀** key to step to the beginning point of each setup section.

<i>SEtUP</i>	See Note Below	Setup Mode (starts at <i>USR=</i> prompt)
<i>R-d</i>	<i>R-d?</i>	Analog to Digital Filtering (starts at <i>dFLt=</i> prompt)
<i>CRl</i>	<i>CRl?</i>	Calibration (starts at <i>CRl l=</i> prompt)
<i>SEt9C</i>	<i>SEt9C?</i>	Set Gravity Constant (starts at <i>CRl9C=</i> prompt)
<i>S io</i>	<i>S io?</i>	Serial Input/Output (starts at <i>bRUd=</i> prompt)
<i>Pr int</i>	<i>Pr int?</i>	Print Tab Settings (starts at <i>Port=</i> prompt)
<i>F SPAn</i>	<i>FSPAn?</i>	Fine Span Adjustment
<i>H i rES</i>	<i>H i rES?</i>	Display High-Resolution Weight
<i>L oC oUt</i>	<i>LCoUt?</i>	Key Lockout Feature Setup
<i>oPt ion</i>	<i>OPt?</i>	Configuration for Indicator Option Boards
<i>FUnC</i>	<i>FUnC?</i>	Function Setup
<i>CoLoR5</i>	<i>CoLoR?</i>	Display Colors Setup

5. If you press the **TARE ↵** key at the *SEtUP* prompt, you may proceed through to the next section (up to and including *CoLoR5*) by pressing the **TARE ↵** key.
6. To exit setup, press the **Fn/▲** key with any of the menu selections displayed.



NOTE: Except for the *SEtUP* prompt, the prompts displayed for each section are different if you push the **UNITS/◀** key to step through the prompts instead of pressing the **TARE ↵** key to proceed through the section.

For example, if you press the UNITS/◀ key with the SEtUP displayed, the next prompt displayed will be R-d. If you step through the setup prompts by pressing the TARE ↵ key, the next prompt displayed will be R-d?

Also, at a prompt with the *?* displayed, you must press the **TARE ↵** key again to proceed with that section.

To skip the section and advance you to the next menu selection, press the **TARE ↵** key twice.

Settings



IMPORTANT! Calibration and Configuration parameters are not stored in the non-volatile memory until *SETUP* is exited. If power is lost while in Setup, any changes made will be lost and the 190 will revert to the previous configuration.

SETUP

USR: (Domestic or International)

With *SETUP* displayed, press the **TARE** \leftarrow key. The display will change to *USR*:. Press the **TARE** \leftarrow key to show the current setting. If the setting displayed is acceptable, press the **TARE** \leftarrow key again to save it.

Otherwise, use the **Fn/▲** key to toggle the setting and press the **TARE** \leftarrow key to save it.

YES (Domestic)

trL: (4% Zero Range) = no
CRP (Capacity) = + 4% to OC
Date Format = MM/DD/YY

no (International)

trL: (4% Zero Range) = yes
CRP (Capacity) = + 9 grads to OC
Date Format = DD/MM/YY

LFt: (Legal-For-Trade)

Press the **TARE** \leftarrow key to show the current setting. If the setting displayed is acceptable, press the **TARE** \leftarrow key again to save it.

Otherwise, use the **Fn/▲** key to toggle the setting and press the **TARE** \leftarrow key to save it.

YES = Interval Settings (*Int*:)
allowed are: 1, 2, 5, 10, 20, 50

no = Interval Setting (*Int*:) is
selectable from 1 to 99.

When both *LFt*:*YES* and *USR*:*YES*, the followings results occur:

Scale must have between 100 and 10,000 divisions
Inhibit serial data during input
trR: (Zero Tracking Range) = 0.5 or 0 to 3
trL: (4% Zero Range) = no
CRP (Capacity) = + 4% to OC

When *LFt*:*YES* and *USR*:*no*, the followings results occur:

UnS: (Motion Range) = 1
trL: (4% Zero Range) = yes
CRP (Capacity) = + 9 grads to OC

Unit 1: (Weighing Unit 1)

Press the **TARE** ↵ key to show the current setting. If the setting displayed is acceptable, press the **TARE** ↵ key again to save it.

Otherwise, use the **Fn/▲** key to toggle to a new setting and press the **TARE** ↵ key to save it. Allowable settings are:

1 = lb (pounds) 2 = kg (kilograms) 3 = oz (ounces) 4 = g (grams)

Int: (Interval Setting)

Press the **TARE** ↵ key to show the current setting.

If **LFt = YES**, use the **Fn/▲** key to toggle to a new setting and press the **TARE** ↵ key to save it. Allowable settings are: 1, 2, 5, 10, 20, or 50.

If **LFt = NO**, use the **Fn/▲** and **UNITS/◀** keys to enter a new setting and press the **TARE** ↵ key to save it. Allowable settings are 1 through 99.

When the setting displayed is acceptable, press the **TARE** ↵ key again to save it.

dPP: (Decimal Point Setting)

Press the **TARE** ↵ key to show the current setting. If the setting displayed is acceptable, press the **TARE** ↵ key again to save it.

Otherwise, use the **Fn/▲** key to toggle to a new setting and press the **TARE** ↵ key to save it. Allowable settings are:

0 = XXXXXX 1 = XXXXX.X 2 = XXXX.XX 3 = XXX.XXX

CRP: (Capacity)

Press the **TARE** ↵ key to show the current setting. If the setting displayed is acceptable, press the **TARE** ↵ key again to save it.

Otherwise, use the **Fn/▲** and **UNITS/◀** keys to enter a new setting and press the **TARE** ↵ key to save it. Allowable capacity settings are 1 through 999,999.

Unit 2: (Weighing Unit 2)

Press the **TARE** ↵ key to show the current setting. If the setting displayed is acceptable, press the **TARE** ↵ key again to save it.

Otherwise, use the **Fn/▲** key to toggle to a new setting and press the **TARE** ↵ key to save it. Allowable settings are:

0 = none 1 = lb (pounds) 2 = kg (kilograms) 3 = oz (ounces) 4 = g (grams)



NOTE: The selection for *Unit 2* cannot be the same as *Unit 1*. Also, dependent upon the selection for *Unit 1*, the interval and decimal point settings, not all unit combinations are available.

Unit 3: (Weighing Unit 3)

Press the **TARE** \leftarrow key to show the current setting. If the setting displayed is acceptable, press the **TARE** \leftarrow key again to save it.

Otherwise, use the **Fn/▲** key to toggle to a new setting and press the **TARE** \leftarrow key to save it. Allowable settings are:

0 = none 1 = lb (pounds) 2 = kg (kilograms) 3 = oz (ounces) 4 = g (grams)



NOTE: The selection for *Unit 3* cannot be the same as *Unit 1* or *Unit 2*. Also, the prompt for *Unit 3*, will not appear if *Unit 2* is 0.

Zero Tracking Range

Press the **TARE** \leftarrow key to show the current setting assigned to the Automatic Zero Tracking Range. This is the value in scale divisions that will be automatically zeroed off. If the setting displayed is acceptable, press the **TARE** \leftarrow key again to save it.

Otherwise, use the **Fn/▲** key to toggle to a new setting and press the **TARE** \leftarrow key to save it. Allowable values are 0 (disables Zero Tracking), 0.5, or 1 through 9.

4% Zero Range

Press the **TARE** \leftarrow key to show the current setting. If the setting displayed is acceptable, press the **TARE** \leftarrow key again to save it.

Otherwise, use the **Fn/▲** key to toggle the setting and press the **TARE** \leftarrow key to save it.

4% Zero Range
4% of scale capacity

Full capacity
Full capacity (no limit)

Power-Up Zero Feature

Press the **TARE** \leftarrow key to show the current setting. If the setting displayed is acceptable, press the **TARE** \leftarrow key again to save it.

Otherwise, use the **Fn/▲** key to toggle the setting and press the **TARE** \leftarrow key to save it.

Power-Up Zero
Automatic Re-Zero on Power-Up

No Re-Zero
No Re-Zero on Power-Up

12 or 24 Time Format

Press the **TARE** \leftarrow key to show the current setting. If the setting displayed is acceptable, press the **TARE** \leftarrow key again to save it.

Otherwise, use the **Fn/▲** key to toggle the setting and press the **TARE** \leftarrow key to save it.

NOTE: In the 24-hour format, 12 is added to all times after noon, i.e., 3 PM would be 1500.

12-hour
12-hour clock (3PM displays 3:00)

24-hour
24-hour clock (3PM displays 15:00)

d in : **X,Y (Digital Input)**

Press the **TARE** \leftarrow key to show the current setting. If the setting displayed is acceptable, press the **TARE** \leftarrow key again to save it.

Otherwise, use the **Fn/▲** key to select the X, Y settings for the Digital Input, and press the **TARE** \leftarrow key to save it.

where:

X = Input transition which activates selected keypad function
(0=open to closed, 1=closed to open)

Y = Keypad function which will be performed

- 0 = Digital Input is disabled
- 1 = **ZERO** key function is performed when input goes from open to closed
- 2 = **PRINT** key function is performed when input goes from open to closed
- 3 = **TARE** key function is performed when input goes from open to closed
- 4 = **NET/GROSS** key function is performed when input goes from open to closed
- 11 = **ZERO** key function is performed when input goes from closed to open
- 12 = **PRINT** key function is performed when input goes from closed to open
- 13 = **TARE** key function is performed when input goes from closed to open
- 14 = **NET/GROSS** key function is performed when input goes from closed to open

d out : **X,Y (Digital Output)**

Press the **TARE** \leftarrow key to show the current setting. If the setting displayed is acceptable, press the **TARE** \leftarrow key again to save it.

Otherwise, use the **Fn/▲** key to select the X, Y settings for the Digital Output, and press the **TARE** \leftarrow key to save it.

where:

X = State below cutoff
(0=Output connected to common, 1=Output not connected to common)

Y = Preset Number or Checkweigher Mode

- 0 = Digital Output is disabled
- 1 = Output connected to common before cutoff with 1 active Preset
- 2 = Output connected to common before cutoff with 2 active Presets
- 3 = Output connected to common before cutoff with 3 active Presets
- 4 = Output connected to common before cutoff on Checkweigher Mode
- 11 = Output not connected to common before cutoff with 1 active Preset
- 12 = Output not connected to common before cutoff with 2 active Presets
- 13 = Output not connected to common before cutoff with 3 active Presets
- 14 = Output not connected to common before cutoff on Checkweigher Mode

SLEEP = (Sleep Mode Feature)

The Sleep Mode feature conserves battery power when the indicator remains unused for a selected period of time. With the feature enabled, the display will be blank.

Press the **TARE** \leftarrow key to show the current status of this feature. If a number other than 0 is shown, this feature is selected and the number shown corresponds to the number of minutes of a stable zero weight reading before the indicator enters the sleep mode.

If the setting displayed is acceptable, press the **TARE** \leftarrow key again to save it.

Otherwise, use the **Fn/▲** and **UNITS/◀** keys to enter a new setting (0 to 10) and press the **TARE** \leftarrow key to store the new setting.

NOTE: Selecting 0 disables this feature.

Auto OFF = (Auto Shutoff)

The Automatic Shutoff feature will automatically turn the indicator off (when it is not in use) after a predetermined period of inactivity to prolong battery life. To turn the indicator back on you must press the **ON/OFF** key.

Press the **TARE** \leftarrow key to show the current status of this feature. A number other than 0 indicates that the auto-shutoff feature is enabled and the displayed number corresponds to the number of minutes of stable weight displayed before the indicator is turned off automatically.

If the setting displayed is acceptable, press the **TARE** \leftarrow key again to save it.

Otherwise, use the **Fn/▲** and **UNITS/◀** keys to enter a new setting (0 to 10) and press the **TARE** \leftarrow key to store the new setting.

NOTE: Selecting 0 disables the Auto-Shutoff feature.

bAtt = (Battery Installed)

Press the **TARE** \leftarrow key to show the current setting. If the setting displayed is acceptable, press the **TARE** \leftarrow key again to save it.

Otherwise, use the **Fn/▲** key to toggle the setting and press the **TARE** \leftarrow key to save it.

bAtt = YES
Battery is Installed

bAtt = no
No Battery Installed



NOTE: If a battery is installed, select *YES* for the *bAtt* = parameter. The battery charger will be turned on automatically upon the power up of the indicator.

TOUCH (Key Touch Sensitivity)

The Key Touch Sensitivity sets the minimum number of milliseconds the key must be touched before the key press is acted upon.

Press the **TARE** ↵ key to show the current status of this feature. If the setting displayed is acceptable, press the **TARE** ↵ key again to save it.

Otherwise, use the **Fn/▲** and **UNITS/◀** keys to enter a new setting (0 to 255) and press the **TARE** ↵ key to store the new setting.

Analog to Digital Filtering

R-d

With *R-d* displayed, press the **TARE** \leftarrow key. The display will change to *dFLt=*. Proceed to the *dFLt=* parameter.

R-d²

With *R-d²* displayed, press the **TARE** \leftarrow key. The display will change to *no*. Press the **Fn/▲** key to toggle to *YES* and press the **TARE** \leftarrow key. The display will change to *dFLt=*. Proceed to the *dFLt=* parameter.

Otherwise, to skip the Analog to Digital Filtering setup, press the **TARE** \leftarrow key to advance to the *CRLP* prompt.

dFLt= (Digital Filtering)

With *dFLt=* displayed, press the **TARE** \leftarrow key to show the current setting. If the setting displayed is acceptable, press the **TARE** \leftarrow key to save it.

Otherwise, use the **Fn/▲** key to toggle to a new setting and press the **TARE** \leftarrow key to save it. Allowable settings are 0, 1, 2, or 3. Note, that if you select 3 (Custom Filtering) two additional prompts will be displayed.

dFLt=

- 0* Filter Level = 2, Break Range = 1
- 1* Filter Level = 6, Break Range = 12, Sample Rate = 2
- 2* Filter Level = 20, Break Range = 12, Sample Rate = 1
- 3 CUSTOM FILTERING

NOTE: The prompts, *F=* (Filter Level) and *b=* (Break Range) will only be displayed if you selected 3 (Custom Filtering) for the *dFLt=* (Digital Filtering) prompt.

* Digital Filtering (*dFLt=*) selections 0, 1, and 2 have fixed factory settings for Filter Level, Break Range, and Sample Rate.

F= (Filter Level)

The filter level is a number from 1 to 99 that corresponds to the level of filtering with 1 being the least and 99 being the greatest. Press the **TARE** \leftarrow key to show the current setting. To accept the setting displayed, press the **TARE** \leftarrow key again to save it.

Otherwise, use the **Fn/▲** and **UNITS/◀** keys to enter a new setting (1 to 99) and press the **TARE** \leftarrow key to save it.

b = (Break Range)

The break range is a number from 1 to 255 that corresponds to the number of division changes to break out of the filtering.

Press the **TARE** \leftarrow key to show the current setting for the break range. If the displayed setting is acceptable, press the **TARE** \leftarrow key to save it.

Otherwise, use the **Fn/▲** and **UNITS/◀** keys to enter a new setting (1 to 255) and press the **TARE** \leftarrow key to save it. **NOTE:** Selecting 0 disables this feature.

5r = (Sample Rate)

Press the **TARE** \leftarrow key to show the current setting for the sample rate. The setting displayed is the sample rate in samples per second. If the displayed setting is acceptable, press the **TARE** \leftarrow key to save it.

Otherwise, use the **Fn/▲** and **UNITS/◀** keys to enter a new setting (1 to 120) and press the **TARE** \leftarrow key to save it.

Un5 = (Motion Range)

The motion range is the number of divisions of change permitted before indicating unstable.

Press the **TARE** \leftarrow key to view the current setting for the range of motion detection. If the displayed setting is acceptable, press the **TARE** \leftarrow key to save it.

Otherwise, use the **Fn/▲** and **UNITS/◀** keys to enter a new range and press the **TARE** \leftarrow key to save the new setting. Allowable range values are 0 through 99 divisions.

5E = (Stable Count)

Stable Count is the number of consecutive stable weight readings before indicating stable weight. This helps filter weight readings for stability when trying to capture stable weight.

Press the **TARE** \leftarrow key to view the current setting for Stable Count. If the displayed setting is acceptable, press the **TARE** \leftarrow key to save it.

Otherwise, use the **Fn/▲** and **UNITS/◀** keys to enter a new setting and press the **TARE** \leftarrow key to save the new setting. Allowable values for the stable count are 1 through 255.

Filter Setting Recommendations

Non-Critical Sample Rate

If the sample rate is not critical, as in static weighing, set:

$$dFLt = 0^* (F = 2, b = 1),$$

$$dFLt = 1^* (F = 6, b = 12, S_r = 2), \text{ or}$$

$$dFLt = 2^* (F = 20, b = 12, S_r = 1).$$

* Digital Filtering ($dFLt$) selections 0, 1, and 2 have fixed factory settings for Filter Level, Break Range, and Sample Rate.

Critical Sample Rate

If the sample rate is critical, as in a filling operation, use Custom Filtering (set $dFLt$ to "3").

1. S_r = SAMPLE RATE (1 to 120 samples/second) determination:

Set the sample rate as close as possible to produce a display graduation change for every graduation of material added to the scale.

$$\frac{\text{Material Flow Rate (lbs/second)}}{\text{Resolution}} = S_r$$

$$\text{EXAMPLE: } \frac{100\text{lbs/sec}}{10\text{lbs}} = 10\text{s/s} = S_r$$

2. b = BREAK RANGE (1 to 255 graduations) determination:

Turn the filtering off by setting the $dFLt$ setting to "0". Operate the system as it will be normally used and, by observation, determine the number of grads of instability that needs to be filtered out. Set the break range (b) to that value.

$$\frac{\text{Weight Change}}{\text{Graduation Value}} = b$$

EXAMPLE: 20,000 x 10lb capacity scale with 800lb variation in the weight display.

$$\frac{800}{10} = b = 80$$

3. F = FILTER SETTING (1 to 99) determination: Set to desired results.
4. If stability is unacceptable with any setting of F , reduce the sample rate and/or increase the break range, b setting for increased filtering.

Calibration

The 190 indicator has six modes that can be used to perform calibration. Four of the modes require a test load or test weights, one requires the scale to be empty (and at zero) and the last uses the calibration “C” numbers from a previous calibration.

CAL

With *CAL* displayed, press the **TARE** \leftarrow key. The display will change to *CAL 1=*. Proceed to the *CAL 1=* parameter.

CALP

With *CALP* displayed, press the **TARE** \leftarrow key. The display will change to *no*. Press the **Fn/▲** key to toggle to *YES* and press the **TARE** \leftarrow key. The display will change to *CAL 1=*. Proceed to the *CAL 1=* parameter.

Otherwise, to skip Calibration, press the **TARE** \leftarrow key to advance to the *SKIP* prompt.

NOTE: During calibration, it will be necessary to enter values using the 190 keypad.

- Pressing the **TARE** \leftarrow key will cause the data entered or displayed to be retained (saved) and the 190 to advance to the next prompt.
- The numeric key functions are replaced by using the **UNITS/◀** and the **Fn/▲** keys.
- The cursor location is identified by the blinking character and can be advanced to the left to the next position by pressing the **UNITS/◀** key.
- Pressing the **Fn/▲** key will change the blinking character to the next value.

Dual-Point with Zero (First Zero) Calibration

This is a standard calibration method requiring one weight, an empty scale, and has one conversion factor.

This method uses two calibration points ($CAL 1=$ and $CAL 2=$) to establish a zero (no load) calibration value and to span the indicator. The two points correspond to zero weight and the test load or test weight and can be applied in any order.

NOTE: This method should be used for first-time calibration and complete recalibration.

$CAL 1=$ – First Calibration Weight

1. The display will show $CAL 1=$. This is the first of two calibration weights. This weight could be ZERO (NO LOAD) or the TEST WEIGHTS (TEST LOAD).
2. Press the **TARE** \leftarrow key to view the current setting.
3. If the first calibration weight is to be ZERO (NO LOAD), press the **TARE** \leftarrow key.
4. If the first calibration weight is to be the TEST WEIGHTS (TEST LOAD), use the **UNITS/◀** and **Fn/▲** keys to input the value of the test weights.
5. Place the weights on the scale platform, then press the **TARE** \leftarrow key.
6. Starting at the left and proceeding right, a series of dashes will appear on the display.
7. Next, starting at the left and proceeding right, the dashes will disappear, after which the display will show: $CAL 2=$.

$CAL 2=$ – Second Calibration Weight

1. The display will show $CAL 2=$. This is the second of two calibration weights. This weight could be ZERO (NO LOAD) or the TEST WEIGHTS (TEST LOAD).
2. Press the **TARE** \leftarrow key to view the current setting.
3. If the second calibration weight is to be ZERO (NO LOAD), press the **TARE** \leftarrow key.
4. If the first calibration weight is to be the TEST WEIGHTS (TEST LOAD), use the **UNITS/◀** and **Fn/▲** keys to input the value of the test weights.
5. Place the weights on the scale platform, then press the **TARE** \leftarrow key.
6. Starting at the left and proceeding right, a series of dashes will appear on the display.
7. Next, starting at the left and proceeding right, the dashes will disappear, after which the display will show: $CAL 3=$.

$CAL 3=$ – Last Calibration Weight

1. The display will show $CAL 3=$. This weight is not used.
2. Press the **UNITS/◀** key to skip $CAL 3=$ and advance to $SETUP$ prompt.

Dual-Point without Zero (False Zero) Calibration

This calibration method requires one test weight and establishes a new conversion factor only. It is used to establish a false zero (temporary zero) without affecting the zero calibration value stored during the last calibration.

This is particularly useful in tank weighing applications, where it may be impractical or impossible to completely empty the tank.

This method uses two calibration points, $[\text{CAL } 1:]$ and $[\text{CAL } 2:]$. The value of the test weight is entered when $[\text{CAL } 1:]$ is displayed and the **NET/GROSS** key is pressed when $[\text{CAL } 2:]$ is displayed.

$[\text{CAL } 1:]$ – First Calibration Weight

1. The display will show $[\text{CAL } 1:]$. This is the first of two calibration weights. This weight could be ZERO (NO LOAD) or the TEST WEIGHTS (TEST LOAD).
2. Press the **TARE** \leftarrow key to view the current setting.
3. If the first calibration weight is to be ZERO (NO LOAD), press the **TARE** \leftarrow key.
4. If the first calibration weight is to be the TEST WEIGHTS (TEST LOAD), use the **UNITS**/ \blacktriangleleft and **Fn**/ \blacktriangle keys to input the value of the test weights.
5. Place the weights on the scale platform, then press the **TARE** \leftarrow key.
6. Starting at the left and proceeding right, a series of dashes will appear on the display.
7. Next, starting at the left and proceeding right, the dashes will disappear, after which the display will show: $[\text{CAL } 2:]$.

$[\text{CAL } 2:]$ – Second Calibration Weight

1. The display will show $[\text{CAL } 2:]$. This is the second of two calibration steps.
2. Remove the weights on the scale platform.
3. Press the **NET/GROSS** key.
4. Starting at the left and proceeding right, a series of dashes will appear on the display.
5. Next, starting at the left and proceeding right, the dashes will disappear, after which the display will show: $5\text{E}6\text{9C}2$.

Single-Point for Span Only (Last Zero) Calibration

This calibration method requires one test weight and establishes a new conversion factor (span) without affecting the zero calibration value stored during the last calibration. This minimizes placing and removing test weights and is especially useful when checking high-capacity scales.

This method uses two calibration points, $CAL 1$ and $CAL 2$. The value of the test weight is entered when $CAL 1$ is displayed and the **ZERO** key is pressed when $CAL 2$ is displayed.

$CAL 1$ – First Calibration Weight

1. The display will show $CAL 1$. This is the first of two calibration steps. This weight is the TEST WEIGHTS (TEST LOAD).
2. Press the **ZERO** key.
3. The display will show $CAL 2$.

$CAL 2$ – Second Calibration Weight

1. Place the weights on the scale platform.
2. Press the **TARE** \leftarrow key to view the current setting.
3. Using the **UNITS**/ \blacktriangleleft and **Fn**/ \blacktriangle keys, input the value of the test weights.
4. Press the **TARE** \leftarrow key.
5. Starting at the left and proceeding right, a series of dashes will appear on the display.
6. Next, starting at the left and proceeding right, the dashes will disappear, after which the display will show: $SET9C2$.

Single-Point for Zero Only (Only Zero) Calibration

This calibration method requires no test weight, an empty scale and establishes a new zero without affecting the conversion factor (span). This is useful to regain the full range of the zero limit when the dead load of the scale has changed. This would occur for example, if a guard rail has been added to the scale platform.

This method uses two calibration points, *CAL 1=* and *CAL 2=*. The **TARE** \leftarrow key is pressed when *CAL 1=* is displayed and the **ZERO** key is pressed when *CAL 2=* is displayed.

CAL 1= – First Calibration Weight

1. The display will show *CAL 1=*. This is the first of two calibration steps.
2. Ensure the scale is empty.
3. Press the **TARE** \leftarrow key.
4. Press the **TARE** \leftarrow key.
5. Starting at the left and proceeding right, a series of dashes will appear on the display.
6. Next, starting at the left and proceeding right, the dashes will disappear, after which the display will show: *CAL 2=*.

CAL 2= – Second Calibration Weight

1. The display will show *CAL 2=*. This is the second of two calibration steps.
2. Press the **ZERO** key.
3. The display will advance to *SEt9C?*.

Multi-Point Calibration

This method requires up to four weights, an empty scale, and has up to four conversion factors. This method uses up to five calibration points ($CAL 1$, $CAL 2$, $CAL 3$, $CAL 4$, and $CAL 5$). The five points correspond to zero weight, up to three midpoint weights, and the test load or test weight and can be applied in any order.

NOTE: This method can be used to correct for system nonlinearity.

$CAL 1$ – First Calibration Weight

1. The display will show $CAL 1$. This is the first of five calibration weights. This weight could be ZERO (NO LOAD) or the TEST WEIGHTS (TEST LOAD).
2. Press the **TARE** \leftarrow key to view the current setting.
3. If the first calibration weight is to be ZERO (NO LOAD), press the **TARE** \leftarrow key.
4. If the first calibration weight is to be the TEST WEIGHTS (TEST LOAD), use the **UNITS**/ \blacktriangleleft and **Fn**/ \blacktriangle keys to input the value of the test weights.
5. Place the weights on the scale platform, then press the **TARE** \leftarrow key.
6. Starting at the left and proceeding right, a series of dashes will appear on the display.
7. Next, starting at the left and proceeding right, the dashes will disappear, after which the display will show: $CAL 2$.

$CAL 2$ – Second Calibration Weight

1. The display will show $CAL 2$. This is the second of two calibration weights. This weight could be ZERO (NO LOAD) or the TEST WEIGHTS (TEST LOAD).
2. Press the **TARE** \leftarrow key to view the current setting.
3. If the second calibration weight is to be ZERO (NO LOAD), press the **TARE** \leftarrow key.
4. If the first calibration weight is to be the TEST WEIGHTS (TEST LOAD), use the **UNITS**/ \blacktriangleleft and **Fn**/ \blacktriangle keys to input the value of the test weights.
5. Place the weights on the scale platform, then press the **TARE** \leftarrow key.
6. Starting at the left and proceeding right, a series of dashes will appear on the display.
7. Next, starting at the left and proceeding right, the dashes will disappear, after which the display will show: $CAL 3$.

CAL3: – Third Calibration Weight

1. The display will show **CAL3:**. This is the second of two calibration weights. This weight could be ZERO (NO LOAD) or the TEST WEIGHTS (TEST LOAD).
2. Press the **TARE** \leftarrow key to view the current setting.
3. If the second calibration weight is to be ZERO (NO LOAD), press the **TARE** \leftarrow key.
4. If the first calibration weight is to be the TEST WEIGHTS (TEST LOAD), use the **UNITS/◀** and **Fn/▲** keys to input the value of the test weights.
5. Place the weights on the scale platform, then press **TARE** \leftarrow key.
6. Starting at the left and proceeding right, a series of dashes will appear on the display.
7. Next, starting at the left and proceeding right, the dashes will disappear, after which the display will show: **CAL4:**.

CAL4: – Fourth Calibration Weight

1. The display will show **CAL4:**. This is the fourth of the calibration weights. This weight could be ZERO (NO LOAD) or the TEST WEIGHTS (TEST LOAD). If the fourth calibration weight is not going to be used, press the **UNITS/◀** key to skip **CAL4:** and advance to **SEE9C?** prompt. Otherwise, proceed to the next step.
2. Press the **TARE** \leftarrow key to view the current setting.
3. If the fourth calibration weight is to be ZERO (NO LOAD), press the **TARE** \leftarrow key.
4. If the fourth calibration weight is to be the TEST WEIGHTS (TEST LOAD), use the **UNITS/◀** and **Fn/▲** keys to input the value of the test weights.
5. Place the weights on the scale platform, then press **TARE** \leftarrow key.
6. Starting at the left and proceeding right, a series of dashes will appear on the display.
7. Next, starting at the left and proceeding right, the dashes will disappear, after which the display will show: **CAL5:**.

CAL5: – Last Calibration Weight

1. The display will show **CAL5:**. This is the fifth of the calibration weights. This weight could be ZERO (NO LOAD) or the TEST WEIGHTS (TEST LOAD). If the fifth calibration weight is not going to be used, press the **UNITS/◀** key to skip **CAL5:** and advance to **SEE9C?** prompt. Otherwise, proceed to the next step.
2. Press the **TARE** \leftarrow key to view the current setting.
3. If the fifth calibration weight is to be ZERO (NO LOAD), press the **TARE** \leftarrow key.
4. If the fifth calibration weight is to be the TEST WEIGHTS (TEST LOAD), use the **UNITS/◀** and **Fn/▲** keys to input the value of the test weights.
5. Place the weights on the scale platform, then press the **TARE** \leftarrow key.
6. Starting at the left and proceeding right, a series of dashes will appear on the display.
7. Next, starting at the left and proceeding right, the dashes will disappear, after which the display will show: **SEE9C?**.

Calibration “[” Numbers



IMPORTANT! If any components have been changed that affect calibration and/or your scale is used in a commercial application and must be "Legal for Trade" you cannot use the “[” numbers to re-calibrate.

The “[” numbers are displayed only during the Test mode operation by pressing the **Fn/▲** key then the **UNITS/◀** key. The “[” numbers are shown at the end of the test operation and each number is displayed for approximately 4 seconds, allowing you to record them. Each number may be up to three (3) digits in length. By recording these numbers, you will be able to return the indicator to its present calibration settings without using test weights simply by entering the “[” numbers.

1. With $[RL] =$ displayed, press **UNITS/◀** key.
2. At $[1 =$ prompt, press **TARE ↵** key to show the current value of $[1$ number.
3. If the $[1 =$ value displayed is acceptable, press **TARE ↵** key again to save it.
4. Otherwise, use **Fn/▲** and **UNITS/◀** keys to enter a new $[1 =$ value and press the **TARE ↵** key.
5. At $[2 =$ prompt, press **TARE ↵** key to show the current value of $[2$ number.
6. If the $[2 =$ value displayed is acceptable, press **TARE ↵** key again to save it.
7. Otherwise, use **Fn/▲** and **UNITS/◀** keys to enter a new $[2 =$ value and press the **TARE ↵** key.
8. At $[3 =$ prompt, press **TARE ↵** key to show the current value of the $[3$ number.
9. If the $[3 =$ value displayed is acceptable, press **TARE ↵** key again to save it.
10. Otherwise, use **Fn/▲** and **UNITS/◀** keys to enter a new $[3 =$ value and press **TARE ↵** key.
11. At $[4 =$ prompt, press the **TARE ↵** key to show the current value of the $[4$ number.
12. If the $[4 =$ value displayed is acceptable, press the **TARE ↵** key again to save it.
13. Otherwise, use **Fn/▲** and **UNITS/◀** keys to enter a new $[4 =$ value and press **TARE ↵** key.
14. The display will change to show: $SEt9[2$.

Set Gravity Constant

The Cardinal 190 Weight Indicator is equipped with an acceleration of gravity function which means that it can be calibrated in one location and then adjusted to match the acceleration of gravity at the location where it will be used.

SEt9C

With *SEt9C* displayed, press the **TARE** \leftarrow key. The display will change to *CAL9C=*. Proceed to the *CAL9C=* parameter.

SEt9C?

With *SEt9C?* displayed, press the **TARE** \leftarrow key. The display will change to *no*. Press the **Fn/▲** key to toggle to *YES* and press the **TARE** \leftarrow key. The display will change to *CAL9C=*. Proceed to the *CAL9C=* parameter.

Otherwise, to skip the Set Gravity Constant setup, press the **TARE** \leftarrow key to advance to the *Stop* prompt.

CAL9C= (Calibrated Gravity Constant)

This is the acceleration of gravity value of the location where the scale was calibrated. Set to 0 if calibrated at the location of operation or if gravity constants are not going to be used.

Press the **TARE** \leftarrow key to show the current setting. If the value displayed is acceptable, press the **TARE** \leftarrow key to save it.

Otherwise, use the **Fn/▲** and **UNITS/◀** keys to enter a new value and press the **TARE** \leftarrow key to save it

OP9C= (Operating Gravity Constant)

This is the acceleration of gravity value for the location where the scale will be operated.

Press the **TARE** \leftarrow key to show the current setting. If the value displayed is acceptable, press the **TARE** \leftarrow key to save it.

Otherwise, use the **Fn/▲** and **UNITS/◀** keys to enter a new value and press the **TARE** \leftarrow key to save it. Consult the factory Tech Support for the Acceleration of Gravity value for your location.

Serial Input/Output

S io

With *S io* displayed, press the **TARE** \leftarrow key. The display will change to *bAudz*. Proceed to the *bAudz* parameter.

S io?

With *S io?* displayed, press the **TARE** \leftarrow key. The display will change to *no*. Press the **Fn/▲** key to toggle to *YES* and press the **TARE** \leftarrow key. The display will change to *bAudz*. Proceed to the *bAudz* parameter.

Otherwise, to skip Serial Input/Output setup, press the **TARE** \leftarrow key to advance to the *Pr int?* prompt.

bAudz (Serial Interface Baud Rate)

Press the **TARE** \leftarrow key to show the current setting. If the setting displayed is acceptable, press the **TARE** \leftarrow key again to save it.

Otherwise, use the **Fn/▲** key to toggle to a new baud rate setting for the serial ports and press the **TARE** \leftarrow key to save it. Allowable settings are:

12 = 1200 Baud	24 = 2400 Baud	48 = 4800 Baud
96 = 9600 Baud	19 = 19200k Baud	38 = 38400 Baud
76 = 76800 Baud		

Pr tyz (Serial Interface Parity Setting)

Press the **TARE** \leftarrow key to show the current setting. If the setting displayed is acceptable, press the **TARE** \leftarrow key again to save it.

Otherwise, use the **Fn/▲** key to toggle to a new setting and press the **TARE** \leftarrow key to save it. Allowable settings are:

- 0 = No Parity with 8 data bits
- 1 = Odd Parity with 7 data bits
- 2 = Even Parity with 7 data bits

Cont 1: (Continuous Output on Serial Interface)

Press the **TARE** ↵ key to show the current setting. If the setting displayed is acceptable, press the **TARE** ↵ key again to save it.

Otherwise, use the **Fn/▲** key to toggle the setting and press the **TARE** ↵ key to save it.

Cont 1: YES

Continuous Output on Serial Interface

Cont 1: NO

No Continuous Output on Serial Interface

If *Cont 1: YES* (Continuous Output) is selected, an additional prompt, *TYPE:* will be displayed.

If *Cont 1: NO* (No Continuous Output) is selected, proceed to the Weight-On- Demand section.

TYPE: (Continuous Output Format)

Press the **TARE** ↵ key to show the current setting. If the setting displayed is acceptable, press the **TARE** ↵ key again to save it.

Otherwise, use the **Fn/▲** key to toggle the setting and press the **TARE** ↵ key to save it.

0 = Continuous Output uses SMA format

1 = Continuous Output uses Cardinal Scoreboard format

SMA Continuous Output Format

If SMA is selected, data will be transmitted in the following format:

<lf><s><r><n><m><f><xxxxxx.xxx><uuu><cr>

Where:

lf = Line Feed

s = Flags Z= center of Zero, O = Overcap, E = zero Error,
e = weight not currently being displayed

r = Range 1 (*always a 1*)

n = Mode G = Gross, T = Tare, N = Net

m = Motion M = Motion, " "(*blank*) = no motion

f = Custom Custom flag

xxxxxx.xxx = Weight Ten characters including a decimal point (if any)

uuu = Units lb, oz, kg, g

cr = Carriage Return (hex 0D)

Cardinal Scoreboard Continuous Output Format

If Cardinal Scoreboard is selected, the data will be transmitted in the following format:

```
<s><xxxxxx><d><uu><m><cc><cr>
```

Where:

s	=	Sign	"-" = negative, " " (<i>blank</i>) = positive
xxxxxx	=	Weight	Six digits
d	=	Decimal point	Added to string if enabled in setup
uu	=	Units	LB, OZ, KG, G
m	=	Mode	G = Gross, N = Net
cc	=	Weight Status	OC = overcapacity CZ = center of zero MO = motion EE = weight not currently being displayed
cr	=	Carriage Return	(hex 0D)

Weight-On-Demand

If the continuous output has not been selected for Serial Port 1 (Cont1=NO), the indicator will respond to a weight request (ENQ).

The host device (computer) sends:

```
ENQ - (hex 05)
```

The 190 will respond:

```
<s><xxxxxx><d><uu><m><cc><cr>
```

where:

s	=	Sign	"-" = negative, " " (<i>blank</i>) = positive
xxxxxx	=	Weight	Six digits
d	=	Decimal point	Added to string if enabled in setup
uu	=	Units	LB, OZ, KG, G
m	=	Mode	G = Gross, N = Net
cc	=	Weight Status	OC = overcapacity CZ = center of zero MO = motion EE = weight not currently being displayed
cr	=	Carriage Return	(hex 0D)

Operation Commands

A connection to the 190 Serial Port RXD serial input can be used to send commands to the indicator. A description of the available commands is described in the section, ASCII Commands.

Print Tab Settings

Print

With *Print* displayed, press the **TARE** \leftarrow key. The display will change to *Port:*. Proceed to the *Port:* parameter.

Print?

With *Print?* displayed, press the **TARE** \leftarrow key. The display will change to *no*. Press the **Fn/▲** key to toggle to *YES* and press the **TARE** \leftarrow key. The display will change to *Port:*. Proceed to the *Port:* parameter.

Otherwise, to skip the Print Tab Settings setup, press the **TARE** \leftarrow key to advance to the *FSPAn?* prompt.

The general format for the input is $A = YY.XX$ where A is the character identifying the data printed, YY is the number of lines down and XX is the number of columns to the right.



NOTE: Enter 00 in either the YY or XX location to disable the data from printing.

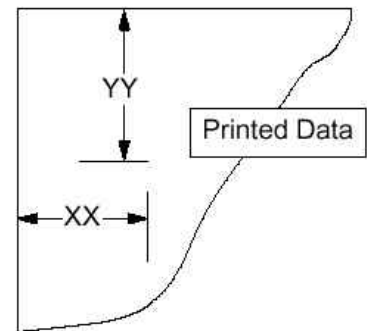

Figure No. 10

Port: **(Select Serial Interface for Printing)**

Press the **TARE** \leftarrow key to show the current setting. If the setting displayed is acceptable, press the **TARE** \leftarrow key again to save it.

Otherwise, use the **Fn/▲** key to toggle to a new setting and press the **TARE** \leftarrow key to save it. Allowable values are:

- 0 = Ticket Printing Disabled
- 1 = Standard Serial Interface used for Printing
- 2 = Optional Serial Interface used for Printing
(Serial Option Card must be installed)

Hour: **(Time Print Location)**

Press the **TARE** \leftarrow key to show the current setting for the Time Print Location. If the setting displayed is acceptable, press the **TARE** \leftarrow key again to save it.

Otherwise, use the **Fn/▲** and **UNITS/◀** keys to enter a new location and press the **TARE** \leftarrow key to save it.

Date: **(Date Print Location)**

Press the **TARE** \leftarrow key to show the current setting for the Date Print Location. If the setting displayed is acceptable, press the **TARE** \leftarrow key again to save it.

Otherwise, use the **Fn/▲** and **UNITS/◀** keys to enter a new location and press the **TARE** \leftarrow key to save it.

Gross (Gross Weight Print Location)

Press the **TARE** ↵ key to show the current setting for the Gross Weight Print Location. If the setting displayed is acceptable, press the **TARE** ↵ key again to save it.

Otherwise, use the **Fn/▲** and **UNITS/◀** keys to enter a new location and press the **TARE** ↵ key to save it.

Tare (Tare Weight Print Location)

Press the **TARE** ↵ key to show the current setting for the Tare Weight Print Location. If the setting displayed is acceptable, press the **TARE** ↵ key again to save it.

Otherwise, use the **Fn/▲** and **UNITS/◀** keys to enter a new location and press the **TARE** ↵ key to save it.

Net (Net Weight Print Location)

Press the **TARE** ↵ key to show the current setting for the Net Weight Print Location. If the setting displayed is acceptable, press the **TARE** ↵ key again to save it.

Otherwise, use the **Fn/▲** and **UNITS/◀** keys to enter a new location and press the **TARE** ↵ key to save it.

Gross ACC (Gross Weight Accumulator Print Location)

Press the **TARE** ↵ key to show the current setting for the Gross Weight Accumulator Print Location. If the setting displayed is acceptable, press the **TARE** ↵ key again to save it.

Otherwise, use the **Fn/▲** and **UNITS/◀** keys to enter a new location and press the **TARE** ↵ key to save it.

Net ACC (Net Weight Accumulator Print Location)

Press the **TARE** ↵ key to show the current setting for the Net Weight Accumulator Print Location. If the setting displayed is acceptable, press the **TARE** ↵ key again to save it.

Otherwise, use the **Fn/▲** and **UNITS/◀** keys to enter a new location and press the **TARE** ↵ key to save it.

Count (Count "number of pieces on the scale" Print Location)

Press the **TARE** ↵ key to show the current setting for the Count Print Location. If the setting displayed is acceptable, press the **TARE** ↵ key again to save it.

Otherwise, use the **Fn/▲** and **UNITS/◀** keys to enter a new location and press the **TARE** ↵ key to save it.

PRCH = (Piece Weight Print Location)

Press the **TARE** ↵ key to show the current setting for the Piece Weight Print Location. If the setting displayed is acceptable, press the **TARE** ↵ key again to save it.

Otherwise, use the **Fn/▲** and **UNITS/◀** keys to enter a new location and press the **TARE** ↵ key to save it.

CR LF = (Carriage Return Line Feed) - Data Format Termination

Data transmitted from the serial I/O port can be terminated with a single carriage return and either no line feed or a single line feed command.

Press the **TARE** ↵ key to view the current setting. A **YES** on the display means the data will be terminated with a carriage return AND a line feed while a **NO** on the display means the data will be terminated with a single carriage return only.

If the setting displayed is acceptable, press the **TARE** ↵ key again to save it.

Otherwise, use the **Fn/▲** key to toggle to a new setting and press the **TARE** ↵ key to save it.

EO P = (End-Of-Print Line Feeds)

At the end of data transmission to a printer, the indicator can transmit a pre-selected number of line feed commands to space the paper in the printer to the desired position for withdrawal or the next print.

Press the **TARE** ↵ key to show the current setting for the End-Of-Print Line Feeds. If the setting displayed is acceptable, press the **TARE** ↵ key again to save it.

Otherwise, use the **Fn/▲** and **UNITS/◀** keys to enter a new number of End-Of-Print linefeeds and press the **TARE** ↵ key to save it. Allowable settings are: 0 through 99

Fine Span Adjustment



IMPORTANT! The *FSPAN* (*FSPAN?*) mode requires a load of 10% of Capacity on the scale before adjustments can be made.

FSPAN

Fine Span Adjustment (from *SETUP* Prompt)

1. If Fine Span Adjustment is desired, with the *SETUP* prompt displayed, press the **UNITS/◀** key until the display shows the *FSPAN* prompt.
2. Place a calibrated test weight on the scale and press the **TARE ↵** key.
3. The display will change to show the amount of the test weight, an *F* will be displayed to the right of the annunciators and the annunciators will alternately flash off and on.
4. Press the **Fn/▲** key to increase the span by 0.5 division OR press the **UNITS/◀** key to decrease the span by 0.5 division.
5. Press the **TARE ↵** key to exit the Fine Span Adjustment and advance to the *HIRESP* prompt.

FSPAN?

Fine Span Adjustment (after pressing **TARE ↵** at last *Print* prompt)

1. With *FSPAN?* displayed, press the **TARE ↵** key.
2. The display will change to *no*.
3. Place a calibrated test weight on the scale.
4. Press the **Fn/▲** key to toggle to *YES* and press the **TARE ↵** key.
5. The display will change to show the amount of the test weight, an *F* will be displayed to the right of the annunciators and the annunciators will alternately flash off and on.
6. Press the **Fn/▲** key to increase the span by 0.5 division OR press the **UNITS/◀** key to decrease the span by 0.5 division.
7. Press the **TARE ↵** key to exit the Fine Span Adjustment and advance to the *HIRESP* prompt.

Display High Resolution Weight



IMPORTANT! The *H r ES* (*H r ES?*) mode requires a load of 10% of Capacity on the scale.

H r ES

High Resolution Weight (from *SEtUP* Prompt)

1. If displaying High Resolution Weight is desired, with the *SEtUP* prompt displayed, press **UNITS/◀** key until the display shows the *H r ES* prompt.
2. Place a calibrated test weight on the scale and press the **TARE ↵** key.
3. The display will change to show the amount of the test weight in "high resolution" mode (1/10 division), an *h* will be displayed to the right of the annunciators and the annunciators will alternately flash off and on.
4. Press the **Fn/▲** key to increase the span by 0.1 division *OR* press the **UNITS/◀** key to decrease the span by 0.1 division.
5. Press the **TARE ↵** key to exit the Display High Resolution Weight and advance to *LoC oUt?* prompt.

H r ES?

High Resolution Weight (after **TARE ↵** pressed at *FSPAn* prompt)

1. With *H r ES?* displayed, press the **TARE ↵** key.
2. The display will change to *no*.
3. Place a calibrated test weight on the scale.
4. Press the **Fn/▲** key to toggle to *YES* and press the **TARE ↵** key.
5. The display will change to show the amount of the test weight in "high resolution" mode (1/10 division), an *h* will be displayed to the right of the annunciators and the annunciators will alternately flash off and on.
6. Press the **Fn/▲** key to increase the span by 0.1 division *OR* press the **UNITS/◀** key to decrease the span by 0.1 division.
7. Press the **TARE ↵** key to exit the Display High Resolution Weight and advance to the *LoC oUt?* prompt.

Key Lockout Feature

The Key Lockout Feature allows keys on the indicator to be disabled for use by the operator “during normal operation”. During normal operation, when the operator presses a locked key, the display will show *LoCkd* for about a 1/2 second and the key will be ignored.



NOTE: The Key Lockout Feature only disables keys for use during normal operation, not setup and calibration.

LoCkOut

With *LoCkOut* displayed, press the **TARE** \leftarrow key. The display will change to show *ZErO*. Proceed to the *ZErO* parameter.

LoCkOut?

With *LoCkOut?* displayed, press the **TARE** \leftarrow key. The display will change to *no*. Press the **Fn/▲** key to toggle to *YES* and press the **TARE** \leftarrow key. The display will change to *ZErO*. Proceed to the *ZErO* parameter.

Otherwise, to skip the Key Lockout Feature setup, press the **TARE** \leftarrow key to advance to the *oPt?* prompt.

ZErO (ZERO Key)

Press the **TARE** \leftarrow key to show the current setting. If the setting displayed is acceptable, press the **TARE** \leftarrow key again to save it.

Otherwise, use the **Fn/▲** key to toggle the setting and press the **TARE** \leftarrow key to save it.

<i>UnLoCkd</i>	<i>LoCkd</i>
Key is Unlocked (Enabled)	Key is Locked (Disabled)

tARrEr (TARE \leftarrow key)

Press the **TARE** \leftarrow key to show the current setting. If the setting displayed is acceptable, press the **TARE** \leftarrow key again to save it.

Otherwise, use the **Fn/▲** key to toggle the setting and press the **TARE** \leftarrow key to save it.

<i>UnLoCkd</i>	<i>LoCkd</i>
Key is Unlocked (Enabled)	Key is Locked (Disabled)

nEt (NET/GROSS Key)

Press the **TARE** \leftarrow key to show the current setting. If the setting displayed is acceptable, press the **TARE** \leftarrow key again to save it.

Otherwise, use the **Fn/▲** key to toggle the setting and press the **TARE** \leftarrow key to save it.

<i>UnLoCkd</i>	<i>LoCkd</i>
Key is Unlocked (Enabled)	Key is Locked (Disabled)

Units (UNITS/◀ Key)

Press the **TARE** ↵ key to show the current setting. If the setting displayed is acceptable, press the **TARE** ↵ key again to save it.

Otherwise, use the **Fn/▲** key to toggle the setting and press the **TARE** ↵ key to save it.

UnLoCk *LoCk*
Key is Unlocked (Enabled) Key is Locked (Disabled)

Func (Fn/▲ Key)

Press the **TARE** ↵ key to show the current setting. If the setting displayed is acceptable, press the **TARE** ↵ key again to save it.

Otherwise, use the **Fn/▲** key to toggle the setting and press the **TARE** ↵ key to save it.

UnLoCk *LoCk*
Key is Unlocked (Enabled) Key is Locked (Disabled)

Print (PRINT Key)

Press the **TARE** ↵ key to show the current setting. If the setting displayed is acceptable, press the **TARE** ↵ key again to save it.

Otherwise, use the **Fn/▲** key to toggle the setting and press the **TARE** ↵ key to save it.

UnLoCk *LoCk*
Key is Unlocked (Enabled) Key is Locked (Disabled)

On (ON/OFF Key)

Press the **TARE** ↵ key to show the current setting. If the setting displayed is acceptable, press the **TARE** ↵ key again to save it.

Otherwise, use the **Fn/▲** key to toggle the setting and press the **TARE** ↵ key to save it.

UnLoCk *LoCk*
Key is Unlocked (Enabled) Key is Locked (Disabled)



IMPORTANT! When the **ON/OFF** key is locked, the display will briefly show "LoCk" and then prompt the operator to press the following keys in this order:

PRINT, ZERO, Fn/▲, TARE ↵, UNITS/◀, NET/GROSS

If no key is pressed or the keys are pressed in the wrong order, the indicator will turn off.

Options Setup

oPt ion

With *oPt* displayed, press the **TARE** \leftarrow key. The display will change to show *oPt =*. Proceed to the *oPt =* parameter.

oPt ?

With *oPt ?* displayed, press the **TARE** \leftarrow key. The display will change to *no*. Press the **Fn/▲** key to toggle to *YES* and press the **TARE** \leftarrow key. The display will change to *oPt =*. Proceed to the *oPt =* parameter.

Otherwise, to skip the Options Setup, press the **TARE** \leftarrow key to advance to the *Func?* prompt.

oPt = (Option)

Press the **TARE** \leftarrow key to show the current setting. If the setting displayed is acceptable, press the **TARE** \leftarrow key again to save it.

Otherwise, use the **Fn/▲** key to toggle to a new setting and press the **TARE** \leftarrow key to save it. Allowable values are:

0 = No Option Card Installed

1 = Serial Interface, Ethernet, Wi-Fi, or USB Option Card Installed
(See Appendix C, D, E and G for details)

2 = not applicable

3 = not applicable

4 = Digital to Analog Converter Option Card Installed
(See Appendix F for details)



IMPORTANT! The settings for the following prompts, *baud =*, *Prty =*, and *Cont? =* are only applied when the *oPt =* parameter is set to 0 or 1.

baud = (Optional Serial Interface Baud Rate)

Press the **TARE** \leftarrow key to show the current setting. If the setting displayed is acceptable, press the **TARE** \leftarrow key again to save it.

Otherwise, use the **Fn/▲** key to toggle to a new baud rate setting for the serial ports and press the **TARE** \leftarrow key to save it. Allowable settings are:

12 = 1200 Baud

24 = 2400 Baud

48 = 4800 Baud

96 = 9600 Baud

19 = 19.2k Baud

38 = 38.4k Baud

76 = 76.8k Baud

Parity: (Optional Serial Interface Parity Setting)

Press the **TARE** ← key to show the current setting. If the setting displayed is acceptable, press the **TARE** ← key again to save it.

Otherwise, use the **Fn/▲** key to toggle to a new setting and press the **TARE** ← key to save it. Allowable settings are:

- 0 = No Parity with 8 data bits
- 1 = Odd Parity with 7 data bits
- 2 = Even Parity with 7 data bits

Cont: (Continuous Output on Optional Serial Interface)

Press the **TARE** ← key to show the current setting. If the setting displayed is acceptable, press the **TARE** ← key again to save it.

Otherwise, use the **Fn/▲** key to toggle the setting and press the **TARE** ← key to save it.

- YES = Continuous Output on Optional Serial Interface
- no = No Continuous Output on Optional Serial Interface



IMPORTANT! The setting for the **TYPE:** is only applied when the **opt:** parameter is set to 1 and the **Cont:** parameter is set to YES.

TYPE: (Continuous Output Format)

Press the **TARE** ← key to show the current setting. If the setting displayed is acceptable, press the **TARE** ← key again to save it.

Otherwise, use the **Fn/▲** key to toggle the setting and press the **TARE** ← key to save it.

- 0 = Continuous Output uses SMA format
- 1 = Continuous Output uses Cardinal Scoreboard format

NOTE: Refer to the **Cont 1:** Continuous Output on Serial Interface, **TYPE:** parameter for a description of output formats.

Function Setup

FUnC

With *FUnC* displayed, press the **TARE** \leftarrow key. The display will change to show *Hold=*. Proceed to the *Hold=* parameter.

FUnCP

With *FUnCP* displayed, press the **TARE** \leftarrow key. The display will change to *no*. Press the **Fn/▲** key to toggle to *YES* and press the **TARE** \leftarrow key. The display will change to *Hold=*. Proceed to the *Hold=* parameter.

Otherwise, to skip the Options Setup, press the **TARE** \leftarrow key to advance to the *Colors* prompt.



IMPORTANT! The Hold, Count, and Live Weight Features should not be enabled if the Legal-For-Trade option (*Lft=YES*) was selected during setup. Also, only one of the features Hold, Count, Peak Hold, Checkweigher, or Live Weight can be enabled at a time.

Hold= (Hold Function)

Press the **TARE** \leftarrow key to show the current setting. If the setting displayed is acceptable, press the **TARE** \leftarrow key again to save it.

Otherwise, use the **Fn/▲** key to toggle the setting and press the **TARE** \leftarrow key to save it.

YES

Hold Function is Enabled

no

Hold Function is Disabled

Count= (Count Function)

Press the **TARE** \leftarrow key to show the current setting. If the setting displayed is acceptable, press the **TARE** \leftarrow key again to save it.

Otherwise, use the **Fn/▲** key to toggle the setting and press the **TARE** \leftarrow key to save it.

YES

Count Function is Enabled

no

Count Function is Disabled

Time-Date= (Time and Date)

Press the **TARE** \leftarrow key to show the current setting. If the setting displayed is acceptable, press the **TARE** \leftarrow key again to save it.

Otherwise, use the **Fn/▲** key to toggle the setting and press the **TARE** \leftarrow key to save it.

YES

Time and Date is Enabled

no

Time and Date is Disabled

PHOLD = (Peak Hold Function)

Press the **TARE** ↵ key to show the current setting. If the setting displayed is acceptable, press the **TARE** ↵ key again to save it.

Otherwise, use the **Fn/▲** key to toggle the setting and press the **TARE** ↵ key to save it.

YES

Peak Hold Function is Enabled

NO

Peak Hold Function is Disabled

CHEC = (Checkweigher Function)

Press the **TARE** ↵ key to show the current setting. If the setting displayed is acceptable, press the **TARE** ↵ key again to save it.

Otherwise, use the **Fn/▲** key to toggle the setting and press the **TARE** ↵ key to save it.

YES

Checkweigher Function is Enabled

NO

Checkweigher Function is Disabled

RELT = (Live Weight Function)

Press the **TARE** ↵ key to show the current setting. If the setting displayed is acceptable, press the **TARE** ↵ key again to save it.

Otherwise, use the **Fn/▲** key to toggle the setting and press the **TARE** ↵ key to save it.

YES

Live Weight Function is Enabled

NO

Live Weight Function is Disabled

ACCU = (Weight Accumulation Function)

Press the **TARE** ↵ key to show the current setting. If the setting displayed is acceptable, press the **TARE** ↵ key again to save it.

Otherwise, use the **Fn/▲** key to toggle the setting and press the **TARE** ↵ key to save it.

YES

Weight Accumulation
Function is Enabled

NO

Weight Accumulation
Function is Disabled

Display Backlight Color Setup

Color5

With *Color5* displayed, press the **TARE** ↵ key. The display will change to show *dFlt=*. Proceed to the *dFlt=* parameter.

Color2

With *Color2* displayed, press the **TARE** ↵ key. The display will change to *no*. Press the **Fn/▲** key to toggle to *YES* and press the **TARE** ↵ key. The display will change to *dFlt=*. Proceed to the *dFlt=* parameter.

Otherwise, to skip the Display Backlight Color setup, press the **TARE** ↵ key to reset the indicator and return to the normal weight display.

dFlt= (Default Display Backlight Color)

Press the **TARE** ↵ key to show the current setting. If the setting displayed is acceptable, press the **TARE** ↵ key again to save it.

Otherwise, use the **Fn/▲** key to toggle to a new setting and press the **TARE** ↵ key to save it. Allowable settings are:

0 = No Backlight	1 = Red Backlight	2 = Green Backlight
3 = Yellow Backlight	4 = Blue Backlight	5 = Pink Backlight

Under= (Checkweigher “Under” Backlight Color)

Press the **TARE** ↵ key to show the current setting. If the setting displayed is acceptable, press the **TARE** ↵ key again to save it.

Otherwise, use the **Fn/▲** key to toggle to a new setting and press the **TARE** ↵ key to save it. Allowable settings are:

0 = No Backlight	1 = Red Backlight	2 = Green Backlight
3 = Yellow Backlight	4 = Blue Backlight	5 = Pink Backlight

Accept= (Checkweigher “Accept” Backlight Color)

Press the **TARE** ↵ key to show the current setting. If the setting displayed is acceptable, press the **TARE** ↵ key again to save it.

Otherwise, use the **Fn/▲** key to toggle to a new setting and press the **TARE** ↵ key to save it. Allowable settings are:

0 = No Backlight	1 = Red Backlight	2 = Green Backlight
3 = Yellow Backlight	4 = Blue Backlight	5 = Pink Backlight

oEr= (Checkweigher “Over” Backlight Color)

Press the **TARE** ↵ key to show the current setting. If the setting displayed is acceptable, press the **TARE** ↵ key again to save it.

Otherwise, use the **Fn/▲** key to toggle to a new setting and press the **TARE** ↵ key to save it. Allowable settings are:

0 = No Backlight 1 = Red Backlight 2 = Green Backlight
3 = Yellow Backlight 4 = Blue Backlight 5 = Pink Backlight

KEYPAD

Standard Key Functions

The Model 190 is equipped with a 7-key Capacitive Touch keypad. The keypad is used to enter commands and data into the indicator. This section describes each key along with its normal function. It is helpful to refer to the actual indicator while reading this section.









The Model 190 uses a capacitive touch keypad that requires a “finger touch” to function. The keypad will not operate with other items such as pens, pencils, or tools.

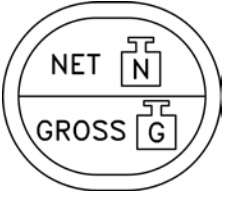

Figure No. 11

Key	Description
	<p>ON/OFF: The ON/OFF key is used to turn the scale on and off.</p> <ul style="list-style-type: none"> • Press the ON/OFF key when the scale is off to turn the scale ON. The indicator will perform a display test (turn on all segments) and then show the model number and software version. • If the scale is already on, press the ON/OFF key and hold for 2 to 3 seconds. When the display shows <i>OFF</i>, release the key to turn the scale OFF.

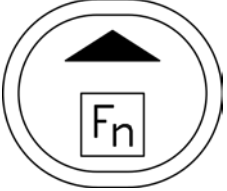
Key	Description
	<p>ZERO: The ZERO key is used to zero the weight display. Up to the selected limit of 4% or 100% of the scale's capacity can be zeroed. This limit is selected during the setup and calibration of the indicator.</p> <p>Note that the indicator will not respond to pressing the ZERO key unless the weight display is stable.</p> <ul style="list-style-type: none"> • When displaying a Tare weight, pressing the ZERO key will clear the Tare value and set the display to Gross mode. • When displaying the Peak weight, pressing the ZERO key will clear the Peak weight. • When displaying the Gross accumulator, pressing the ZERO key will clear the Gross accumulator. • When displaying the Net accumulator, pressing the ZERO key will clear the Net accumulator.
	<p>TARE ↵ (Enter): The TARE ↵ key is used during normal operation to store the current Gross weight as the new Tare weight. The display will change to the Net weight and the Net annunciator will turn on.</p> <p>During Setup, pressing the TARE ↵ key will display the current setting of the parameter. Pressing the TARE ↵ key a second time (after changing parameter values or settings), signals the completion of the entry of data and causes the indicator to process the data entered.</p>
	<p>NET/GROSS: The NET/GROSS key is used to toggle between the Gross and Net weight modes. The selected mode is indicated by turning on the appropriate annunciator on the display.</p> <p>Note that if no valid tare weight has been entered, pressing the NET/GROSS key will cause a momentary display error (<i>no tARE</i>) and the indicator will remain in the Gross weight mode.</p> <p>When in Hold, Count, Peak weight, Live weight, or Accumulator display mode, press the NET/GROSS key to return the display to normal weight display mode.</p>
	<p>UNITS/◀ (Left Arrow): The UNITS/◀ key is used for several functions.</p> <ul style="list-style-type: none"> • In normal operation, the UNITS/◀ key is used to select the units in which the weight is to be displayed. The available units of measure ("unit1", "unit2", and "unit3") are selected in setup. The available units include pounds, ounces, kilograms, and grams. <p>During setup, the UNITS/◀ key is used to advance the cursor left to the next position when inputting setup parameters.</p>

Key	Description
	<p>Fn/▲ (Up Arrow): The Fn/▲ key is used for several functions.</p> <ul style="list-style-type: none"> • During indicator setup, when a setup parameter (not a parameter value or setting) is displayed, pressing the Fn/▲ key will "backup" to the previous parameter prompt. • Also, during setup when a parameter value or setting is displayed, pressing the Fn/▲ key will "toggle" between the different available values or settings for that parameter. <p>In normal operation, the Fn/▲ key is used in conjunction with the other keys on the keypad to access additional indicator features.</p>
	<p>PRINT: Pressing the PRINT key during a weighing operation, will add the displayed Gross weight, or Net weight to the associated accumulator and send print ticket data to the serial interface selected during setup (see <i>Port =</i>).</p> <p>NOTE: The indicator will not respond to pressing the PRINT key unless the weight display is stable.</p>

Fn/▲ Key Functions

The **Fn/▲** key is used to select several additional functions that may have been enabled during the setup and calibration of the indicator. Those functions include Hold, Count, Time and Date, Peak Hold, Checkweigher, Live Weight, Weight Accumulation, and Backlight Color.



IMPORTANT! The Hold, Count, and Live Weight functions cannot be enabled if the Legal-For-Trade option (*L F t = Y E S*) was selected during setup.

Also, only one of the functions Hold, Count, Peak Hold, Checkweigher, or Live Weight can be enabled at a time.

Description of Fn/▲ Key Functions

Function	Display	Description or Setting
Hold	<i>H o L d</i> X	X will be 1 if enabled, 0 if disabled
Count	<i>C o U n t</i> X	X will be 1 if enabled, 0 if disabled
Time and Date	HH:MM A MM.DD.YY (<i>U S R = Y E S</i>) DD.MM.YY (<i>U S R = n o</i>)	HH=hours, MM=minutes, A for AM, P for PM MM=month, DD=day, YY=last two digits of year
Peak Hold	<i>P h o L d</i> X	X will be 1 if enabled, 0 if disabled
Checkweigher	<i>L o z</i> X*	Minimum acceptable weight prompt = minimum acceptable weight value. * When the value for <i>L o z</i> is greater than 0, the Checkweigher function is enabled.
	<i>H i z</i> X	Maximum acceptable weight prompt. This prompt is displayed, when the value for <i>L o z</i> is greater than 0. = maximum acceptable weight value
Live Weight	<i>R e t</i> X	X will be 1 if enabled, 0 if disabled
Weight Accumulation	<i>R C C U</i> X	X will be 1 if enabled, 0 if disabled
Backlight Color	<i>C o L o r S</i>	Backlight Colors for normal operation and Checkweigher results

Fn/▲ Key Combination Features

The **Fn/▲** key is also used in combination with the other keys on the keypad to access additional indicator features. Those features and their associated key combinations are as follows:

Fn/▲, ZERO KEY

This combination will enter the Review mode of Setup and Calibration. Refer to the Setup Review section of this manual for details.

Fn/▲, TARE ↵ KEY

This combination will display the Tare weight. If a tare weight has not been stored, then the *not RrE* error message will be displayed.

Fn/▲, NET/GROSS KEY

This combination will allow viewing of the Audit Trail Counters. Refer to the View Event Counters section of this manual for details.

Fn/▲, UNITS/◀ KEY

This combination will enter the Test Mode/Diagnostics Feature. This feature is used to conduct a test of all display elements and perform self-diagnostics. Refer to the Test/Mode/Diagnostics section of this manual for details.

Fn/▲, PRINT KEY

This key combination is used for several functions. Print formats are selected by using the **Fn/▲** key and **PRINT** keys in combination. Note that when the **PRINT** key is pressed the indicator looks for the selected format. If no visual ticket is found it reverts to the print tab settings. Refer to the Operation, Ticket Format Selection for details.

This key combination is also used to enter the Preset Weight Comparators “PWC” weight values. Refer to the Operation, Preset Weight Comparators section for details.

ANNUNCIATORS

The Model 190 is equipped with annunciators that are turned on to indicate that the display is in the mode corresponding to the annunciator label or that the status indicated by the label is active. This section describes each annunciator. Refer to the illustration below for the location of the annunciators.

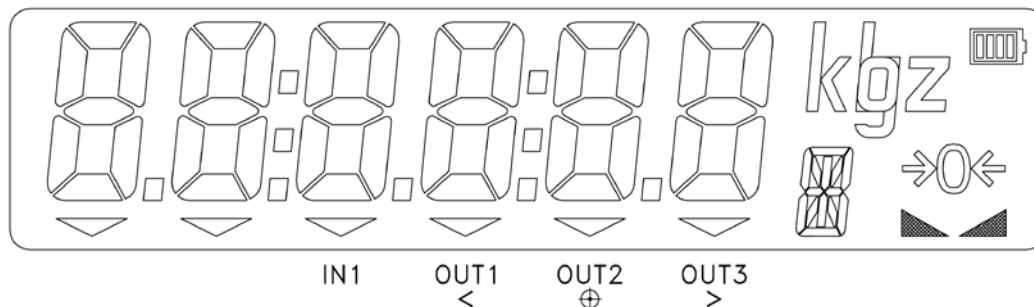

Symbol	Name	Description
→0←	ZERO	This annunciator is turned on to indicate that the weight displayed is within $\pm 1/4$ division of true zero.
▲▼	STABLE	This annunciator is turned on when the weight display is stable. When off, it means that the change in successive weight samples is greater than the motion limits selected during setup.
n	NET	This annunciator is turned on when the displayed weight is Net weight (Gross weight less Tare weight).
G	GROSS	This annunciator is turned on to show that gross weight is displayed. Gross weight will be displayed when no tare weight is stored.
T	TARE	This annunciator is turned on to show that the displayed weight is the tare weight.
lb	pounds	This annunciator is located to the right of the weight display and is turned on to show that the displayed weight unit is pounds.
oz	ounces	This annunciator is located to the right of the weight display and is turned on to show that the displayed weight unit is ounces.
kg	kilograms	This annunciator is located to the right of the weight display and is used to indicate that the displayed unit of weight measurement is kilograms.
g	grams	This annunciator is located to the right of the weight display and is used to indicate that the displayed unit of weight measurement is grams.

Symbol	Name	Description
\lfloor	COUNT	This annunciator shows that the display is in the Count mode and the value displayed is in pieces (the count quantity) and not weight.
\lfloor And \uparrow or \downarrow And \uparrow	ACCUMULATOR	This annunciator shows that the displayed value is the content of the accumulator.
\blacktriangledown IN1	DIGITAL INPUT	This annunciator is used to signal that a remote key function has been activated. Note that this annunciator is active only when the Digital Input feature has been enabled. Refer to the d_{in} parameter in Setup.
\blacktriangledown OUT1 <	UNDER	This annunciator is used to signal that the displayed weight is less than the minimum value of acceptable weight used in the Checkweigher feature or that preset 1 is active. Note that this annunciator is active only when the Checkweigher feature or the preset feature has been enabled. Refer to the d_{out} parameter in Setup.
\blacktriangledown OUT2 \oplus	ACCEPT	This annunciator is used to signal that the displayed weight is within the acceptable weight limits for the Checkweigher feature. That is, the weight is equal to or greater than the minimum acceptable weight and equal to or less than the maximum acceptable weight. This annunciator is also used to indicate that preset 2 is active. Note that this annunciator is active only when the Checkweigher feature or the preset feature has been enabled. Refer to the d_{out} parameter in Setup.
\blacktriangledown OUT3 >	OVER	This annunciator is used to signal that the displayed weight is equal to or greater than the minimum value of overweight used in the Checkweigher feature This annunciator is also used to indicate that preset 3 is active. Note that this annunciator is active only when the Checkweigher feature or the preset feature has been enabled. Refer to the d_{out} parameter in Setup.

Battery Status

The battery status indicator will be displayed when a battery pack is installed. The number of bars indicates the level of charge.

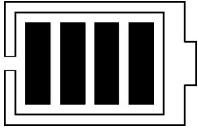

Number of Bars	Level of Charge
4	100%
3	75%
2	50%
1	25%



NOTE: When the indicator is connected to an external power supply and is charging the battery, the charge level status bars will scroll. Also, as the battery approaches full discharge, the outline of the battery will start to flash.

INDICATOR SETUP REVIEW

The 190 indicator allows several operational parameters to be reviewed and changed without breaking the calibration seal.

Accessing Setup Review

1. With the indicator ON, press the **Fn/▲** key and then the **ZERO** key.
2. The display will change to show `t d :` (the prompt for selection of a 12 or 24-hour clock).
3. Press the **TARE ↵** key to show the current setting. If the setting displayed is acceptable, press the **TARE ↵** key again to save it. Otherwise, use the **Fn/▲** key to toggle to a new setting and press the **TARE ↵** key to save it and advance to the next prompt.
4. To exit Setup Review, press the **TARE ↵** key to step through the remaining prompts *OR* at any time, cycle the power (press the **ON/OFF** key twice).

<code>t d :</code>	Time and Date (Select 12 or 24-hour clock)
<code>d i n :</code>	Digital Input (Disable or Select key function)
<code>d o u t :</code>	Digital Output (Disable or Select Preset/Checkweigher function)
<code>S L E E P :</code>	Sleep Mode (Disable or Select number of minutes before entering sleep mode)
<code>R o f f :</code>	Auto Shutoff (Disable or Select number of minutes before automatic shutoff)
<code>t o u c h :</code>	Key Touch Sensitivity (Select number of milliseconds key must be touched before the key press is acted upon)
<code>S i o ?</code>	Serial Input/Output Configuration (Select YES or NO)
<code>b a u d :</code>	Select Serial Port Baud Rate
<code>p r t y :</code>	Select Serial Port Parity
<code>C o n t i :</code>	Enable or Disable Continuous Output to the Serial Port
<code>t y p e :</code>	If <code>C o n t i = Y E S</code> (Select Continuous Output Format, SMA or Cardinal Scoreboard)

Print? Print Tab Settings Configuration
 (Select YES or NO)

Port: Disable or Select Serial Interface for Printing

Hour: Time Print Location

date: Date Print Location

Gross: Gross Weight Print Location

tare: Tare Weight Print Location

net: Net Weight Print Location

G ACC: Gross Weight Accumulator Print Location

n ACC: Net Weight Accumulator Print Location

Count: Count "number of pieces on the scale" Print Location

ERCH: Piece Weight Print Location

CR LF: Carriage Return Line Feed (*Data Format Termination*)

EOP: End-Of-Print Line Feeds

opt? Options Configuration
 (Select YES or NO)

opt: Select Option Card Installed

baud: Select Option Card Baud Rate when *opt = 0* or *1*

parity: Select Option Card Parity when *opt = 0* or *1*

cont2: Enable or Disable Continuous Output to the Option Port

type: If *opt = 1* and *cont2 = YES*
 (Select Continuous Output Format, SMA or Cardinal Scoreboard)

baud: Select Field Bus Option Baud Rate when *opt = 2*

addr: Select Field Bus Option MAC Address when *opt = 2*

color? Display Backlight Color Setup
 (Select YES or NO)

dflt: Select Default Backlight Color

under: Select Checkweigher "Under" Backlight Color

accept: Select Checkweigher "Accept" Backlight Color

over: Select Checkweigher "Over" Backlight Color

OPERATION

Ticket Format Selection

The 190 includes support for visual tickets. Visual tickets are designed by the PC-based programs Visual Print or nControl and then downloaded to the indicator.

The 190 allows one programmable format in addition to the standard print tab settings format.

1. Press the **Fn/▲** key then the **PRINT** key.
2. The display will change to show *P r t :*.
3. Press the **TARE ↵** key to show the current value.
4. If the setting displayed is acceptable, press the **TARE ↵** key again to save it.
5. Otherwise, press the **Fn/▲** key to "toggle" between the different available settings and press the **TARE ↵** key to save it. Allowable settings are:

0 = print tab settings

1 = visual ticket format



NOTE: When a print format is selected, it will remain active until changed by the operator.

```
10:19 08/23/2013
100.00 lb G
20.00 lb T
80.00 lb N
  0.00 lb GROSS ACCUM
272.00 lb NET ACCUM
```

TICKET EXAMPLE

Preset Weight Comparators

The Model 190 has three (3) outputs, which can be configured during setup to perform as Preset Weight Comparators “PWC”. The output state of each PWC (before reaching the preset weight) is defined in the section SETUP, *d o u t =* (Digital Output) parameter.

With the PWC feature selected, during operation, the indicator will compare each enabled preset weight value with the displayed weight and then output a signal for each preset based on the comparison results.

Entering Preset Weight Comparators Values

1. To enter the Preset Weight Comparators values, simultaneously press the **Fn/▲** key and the **PRINT** key.
2. The display will change to show *P r t =* (the prompt for Print Ticket Format selection). Refer to the previous section for details on selecting a Print Ticket Format.
3. Press the **TARE ←** key again to skip the Print Ticket Format selection.
4. The display will change to show *P S E t =*.
5. Press the **TARE ←** key to display the current value of the first preset weight value.
6. If the setting displayed is acceptable, press the **TARE ←** key again to save it.
7. Otherwise, use the **Fn/▲** and **UNITS/◀** keys to enter a new value for the preset weight.
8. When the desired value is displayed, press the **TARE ←** key to save it.
9. Continue with this procedure until a value for each preset to be used has been entered.
10. After the last preset value has been entered and the **TARE ←** key pressed, the indicator will return to the weight display.

Preset Weight Comparators Operation

The preset weight comparators are used to control peripheral devices used in some form of process control. The number of comparators used depends upon system needs.

For example, in a simple filling operation, a single comparator may be used to open or close a gate that dumps material on the scale. In a more complex application, more comparators may be used for high-speed/low-speed filling.

The *d o u t =* (Digital Output) setup parameter selects how many comparators are being used and the state of the output when the scale weight is below the preset target or cutoff weight. The output can be in one of two states: connected to the common pin on the I/O connector or not connected to the common pin on the I/O connector. When the scale weight is greater than or equal to the cutoff weight, the output will change state.

Hold Function

With the Hold function enabled during setup of the indicator, the function must be activated before it can be used. Refer to the section Function Setup, the *FUNC (FUNC?)* parameter to enable the **Fn/▲** key Hold function.



NOTE: This function is not available when Legal-For-trade (*LFt = YES*) has been selected in setup. Also, only one of the functions Hold, Count, Peak Hold, Checkweigher, or Live Weight can be active at a time.

Activate Hold Function

1. Press and hold the **Fn/▲** key until the display blanks.
2. Once the display blanks, release the **Fn/▲** key
3. The display will change to show *Hold X*, the prompt, and status of the Hold function.
4. If the setting displayed is acceptable, press the **TARE ↵** key to save it. Otherwise, use the **Fn/▲** key to toggle to a new setting and press the **TARE ↵** key to save it.

I = Hold Function Active

0 = Hold Function Not Active

5. Repeatedly press the **TARE ↵** key to step through the remaining function prompts until the indicator returns to the weight display.

Hold Function Operation

1. With the Hold function enabled and activated, momentarily press the **Fn/▲** key and the display will lock at its current weight reading.
2. Press the **PRINT** key to print the held reading.
3. Press the **NET/GROSS, ZERO, TARE ↵**, or **UNITS/◀** key to release the hold and return to the weight display.

Count Function

With the Count function enabled during setup of the indicator, the function must be activated before it can be used. Refer to the section Function Setup, the *FUNC (FUNC?)* parameter to enable the **Fn/▲** key Count function.



NOTE: This function is not available when Legal-For-trade (*LFt = YES*) has been selected in setup. Also, only one of the functions Hold, Count, Peak Hold, Checkweigher, or Live Weight can be active at a time.

Activate Count Function

1. Press and hold the **Fn/▲** key until the display blanks.
2. Once the display blanks, release the **Fn/▲** key
3. Press the **TARE** \leftarrow key until the display shows *Count X*, the prompt, and the status of the Count function.
4. If the setting displayed is acceptable, press the **TARE** \leftarrow key to save it. Otherwise, use the **Fn/▲** key to toggle to a new setting and press the **TARE** \leftarrow key to save it.

! = Count Function Active

0 = Count Function Not Active

5. Repeatedly press the **TARE** \leftarrow key to step through the remaining function prompts until the indicator returns to the weight display.

Count Function Operation

1. Press the **Fn/▲** key. If no average piece weight has been set, the display will show *Add = 5*.
2. Repeatedly press the **Fn/▲** key to cycle through the sample sizes 5, 10, 25, 50, and 75 pieces.
3. Alternatively, press the **UNITS/◀** key. The digit will start to flash.
4. Repeatedly press the **Fn/▲** key until the desired value is displayed.
5. Press the **UNITS/◀** key to select the next digit.
6. Add the number of pieces to the scale and press the **TARE** \leftarrow key.
7. The display will change to show the number of pieces on the scale.
8. Additional pieces may be added and the display will show the total number of pieces.
9. Press the **NET/GROSS** key to return to the weight display.

After the average piece weight has been set, pressing the **Fn/▲** key will go directly to displaying piece count.

To change the average piece weight, press the **Fn/▲** key a second time, and the *Add = 5* prompt will be displayed.

To quit the sampling process without changing the average piece weight, set the sample size to 0 and press the **TARE** \leftarrow key.

Time and Date Functions

With the Time and Date function enabled during setup of the indicator, the function must be activated before it can be used. Refer to the section Function Setup, the *FUNC (FUNC?)* parameter to enable the **Fn/▲** key Time and Date function.



If *USA=YES*, the date format is month-day-year.

If *USA=NO*, the date format is day-month-year.

Set the Time

1. Press and hold the **Fn/▲** key until the display blanks.
2. Once the display blanks, release the **Fn/▲** key
3. Press the **TARE** \leftarrow key until the display shows the time prompt, HH:MM X. Note that X will be A for AM or P for PM.
4. If the time displayed is correct, press the **TARE** \leftarrow key to save it.
5. Otherwise, press the **Fn/▲** key to toggle between A and P.
6. Next, press the **UNITS/◀** key to select the digit of the minutes or hour to change.
7. Press the **Fn/▲** key to change the digit's value.
8. When the correct time is displayed, press the **TARE** \leftarrow key to save it.
9. Repeatedly press the **TARE** \leftarrow key to step through the remaining function prompts until the indicator returns to the weight display.

Set the Date

1. Press and hold the **Fn/▲** key until the display blanks.
2. Once the display blanks, release the **Fn/▲** key.
3. Press the **TARE** \leftarrow key until the display shows the date prompt.
4. If the date displayed is correct, press the **TARE** \leftarrow key to save it.
5. Otherwise, use the **UNITS/◀** key to select the digit of the month, day, or year to change and use the **Fn/▲** key to change the digit's value.
6. When the correct date is displayed, press the **TARE** \leftarrow key to save it.
7. Repeatedly press the **TARE** \leftarrow key to step through the remaining function prompts until the indicator returns to the weight display.

Peak Hold Function

With the Peak Hold function enabled during setup of the indicator, the function must be activated before it can be used. Refer to the section Function Setup, the *FUNC (FUNC?)* parameter to enable the **Fn/▲** key Hold function.



NOTE: Only one of the functions Hold, Count, Peak Hold, Checkweigher, or Live Weight can be active at a time.

Activate Hold Function

1. Press and hold the **Fn/▲** key until the display blanks.
2. Once the display blanks, release the **Fn/▲** key
3. The display will change to show *PHoLdX*, the prompt, and status of the Peak Hold function.
4. If the setting displayed is acceptable, press the **TARE** \leftarrow key to save it. Otherwise, use the **Fn/▲** key to toggle to a new setting and press the **TARE** \leftarrow key to save it.

I = Peak Hold Function Active

□ = Peak Hold Function Not Active

5. Repeatedly press the **TARE** \leftarrow key to step through the remaining function prompts until the indicator returns to the weight display.

Peak Hold Function Operation

When the Peak Hold function is active, the largest weight value measured since Peak Hold was activated (or cleared) will be stored.

1. To display the peak value, momentarily press the **Fn/▲** key.
2. To zero the peak value, make sure there is no load on the scale and press the **ZERO** key.
3. Press the **NET/GROSS** key to return to the weight display.

Checkweigher

The Model 190 has logic level outputs that can be used to control peripheral devices used to signal when the weight is within preset limits. The output state of the Checkweigher (before reaching the preset weight) is defined in the section SETUP, the *d out =* (Digital Output) parameter.



NOTE: These outputs are at logic level and cannot drive external devices directly. Solid-state relays can be used to accept the logic level outputs from the 190 and in turn, drive the external device.

With the Checkweigher function enabled during setup of the indicator, the function must be activated before it can be used. Refer to the section Function Setup, the *FUNC (FUNC?)* parameter to enable the **Fn/▲** key Hold function.



NOTE: Only one of the functions Hold, Count, Peak Hold, Checkweigher, or Live Weight can be active at a time.

Target Weight Setup

1. Press and hold the **Fn/▲** key until the display blanks.
2. Once the display blanks, release the **Fn/▲** key
3. The display will change to show the first function prompt.
4. Repeatedly press the **TARE** \leftarrow key until the *L o l =* prompt is displayed.
5. Press the **TARE** \leftarrow key once again.
6. The display will show the current value for the minimum acceptable weight for ID 1.
7. If the setting displayed is acceptable, press the **TARE** \leftarrow key to save it.
8. Otherwise, use the **Fn/▲** and **UNITS/◀** keys to enter a new value for the minimum acceptable weight for ID 1.
9. When the desired weight value is displayed, press the **TARE** \leftarrow key to save it.
10. The display will change to show the *H i l =* prompt.
11. Press the **TARE** key again.
12. The display will show the current value for the maximum acceptable weight for ID 1.
13. If the setting displayed is acceptable, press the **TARE** key to save it.
14. Otherwise, use the **Fn/▲** key and **UNITS/◀** key to enter a new value for the maximum acceptable weight for ID 1.
15. When the desired value is displayed, press the **TARE** key to save it.
16. The display will change to show the *L o 2 =* prompt.
17. Repeat steps 5 to 9 to set the value for the minimum acceptable weight for ID 2.
18. The display will change to show the *H i 2 =* prompt.

19. Repeat steps 11 to 15 to set the value for the maximum acceptable weight for ID 2.
20. Continue to enter the minimum and maximum acceptable weights for the remaining IDs for up to ten (10) IDs, or press the **UNITS/◀** key at the *L o n =* prompt or the *H i n =* prompt to skip the entry of the remaining weights.
21. Repeatedly press the **TARE** key to step through the remaining function prompts until the indicator returns to the weight display.
22. Note that if the low weight for ID 1 is set to 0, the Checkweigher function will be *disabled*. The low and high weights must be less than scale capacity and the high weight must be greater than the low weight.

Target Weight Selection

1. From the weight display, briefly press and release the **Fn/▲** key.
2. The display will show the prompt *t d =*.
3. Press the **TARE** key.
4. The display will show the ID of the currently selected target weight.
5. If the setting displayed is acceptable, press the **TARE** key to save it.
6. Otherwise, use the **Fn/▲** key to enter a new value for the ID.
7. When the desired value is displayed, press the **TARE** key to save it.
8. The indicator will return to the weight display.

Checkweigher Operation

With the Checkweigher function enabled and activated, during operation the indicator will compare the displayed weight with the preset values and display the results as under, accept, or over.

When the displayed weight is less than the minimum acceptable weight, the arrow over **OUT1 <** (the UNDER annunciator) will turn on and the display will change to the color selected in the section, Display Backlight Color Setup.

When the displayed weight is greater than the maximum acceptable weight, the arrow over **OUT3 >** (the OVER annunciator) will turn on and the display will change to the color selected in the section, Display Backlight Color Setup.

When the displayed weight is within the range from minimum acceptable weight to maximum acceptable weight, the arrow over **OUT2 ⊕** (the ACCEPT annunciator) will turn on and the display will change to the color selected in the section, Display Backlight Color Setup.

Live Weight Function

With the Live Weight function enabled during setup of the indicator, the function must be activated before it can be used. Refer to the section, Function Setup, the *FUNC (FUNC?)* parameter to enable the **Fn/▲** key Hold function.



NOTE: This function is not available when Legal-For-trade (*LFt = YES*) has been selected in setup. Also, only one of the functions Hold, Count, Peak Hold, Checkweigher, or Live Weight can be active at a time.

Activate Live Weight Function

1. Press and hold the **Fn/▲** key until the display blanks.
2. Once the display blanks, release the **Fn/▲** key
3. The display will change to show *RLt X*, the prompt, and status of the Live Weight function.
4. If the setting displayed is acceptable, press the **TARE ↵** key to save it. Otherwise, use the **Fn/▲** key to toggle to a new setting and press the **TARE ↵** key to save it.

! = Live Weight Function Active

0 = Live Weight Function Not Active

5. Repeatedly press the **TARE ↵** key to step through the remaining function prompts until the indicator returns to the weight display.

Live Weight Function Operation

With the Live Weight function enabled and activated, make sure the scale platform is empty, and then simultaneously press the **NET/GROSS** and the **UNITS/◀** key.

The Hold annunciator will flash.

Load the scale platform.

When a stable value has been reached, the Hold annunciator will be on steadily and the display will lock.

Press the **NET/GROSS** key to return to the weight display.

Accumulated Weight Function

When the accumulated weight function has been enabled during setup of the indicator, the function must be activated before it can be used. Refer to the section, Function Setup, the *FUNC (FUNC?)* parameter to enable the **Fn/▲** key Hold function.



NOTE: If Legal-For-trade (*LFt = YES*) has been selected in setup, the Gross weight must return to zero before the next weighing operation to enable accumulation.

Activate Accumulated Weight Function

1. Press and hold the **Fn/▲** key until the display blanks.
2. Once the display blanks, release the **Fn/▲** key
3. The display will change to show *ACCU X*, the prompt, and status of the Accumulated Weight function.
4. If the setting displayed is acceptable, press the **TARE ↵** key to save it. Otherwise, use the **Fn/▲** key to toggle to a new setting and press the **TARE ↵** key to save it.

i = Accumulated Weight Function Active

o = Accumulated Weight Function Not Active

5. Repeatedly press the **TARE ↵** key to step through the remaining function prompts until the indicator returns to the weight display.

Accumulated Weight Function Operation

During operation, the weight recorded when the **PRINT** key is pressed will be added to the accumulator. This will be indicated by *totRL* being displayed briefly after the **PRINT** key has been pressed.

1. To display the Accumulator, simultaneously press the **UNITS/◀** and **TARE ↵** keys. If Legal-For-trade (*LFt = YES*) is on, the gross load must be zero.
2. The Gross accumulator weight will be shown as indicated by the alternating *o* and *R*.
3. After a brief interval, the display will show the number of Gross weight items accumulated, indicated by the alternating *o* and *L*.
4. The display will alternate between showing the Gross accumulator weight and the Gross accumulator count.
5. Press the **TARE ↵** key and the Net accumulator weight will be displayed, indicated by the alternating *n* and *R*.
6. After a brief interval, the display will show the number of Net weight items accumulated, indicated by the alternating *n* and *L*.
7. The display will alternate between showing the Net accumulator weight and the Net accumulator count.
8. Press the **TARE ↵** key to display the Gross accumulator again.
9. Press the **ZERO** key to clear the displayed accumulator.
10. Press the **NET/GROSS** key to return to the normal weight display.

Touch Key Lock Out Function

The 190 firmware provides a means for locking out the capacitive touch keys. When the keys are locked out, any activation of the keys, whether intentional or accidental, will be ignored.



NOTE: This function is available in firmware version 1.0.13 or newer.

Lock Out the Keys

1. To lock out the keys, touch the **ON/OFF**, **PRINT**, **Fn**, and **UNITS** keys sequentially in that order within approximately four seconds.
2. The display will briefly show *L o c k e d*.
3. If any key is touched, all of the key LEDs will flash briefly and the touch will be ignored. Note that it is not possible to turn the indicator off with the **ON/OFF** key when the keys are locked out.

Re-Enable the Locked-Out Keys

1. To re-enable the keys, touch the **ON/OFF**, **PRINT**, **Fn**, and **UNITS** keys sequentially in that order within approximately four seconds.
2. The display will briefly show *U n l o c k e d*.
3. Normal touch key operation will resume.



NOTE: If power is lost when the keys are locked out, the keys will not be locked out when power is restored. The key sequence for locking out the keys will have to be entered again to lock out the keys.

ASCII Commands

The Model 190 indicator will respond to ASCII commands when input to the 190's internal serial port, the 190-RS232 option card, the 190-IP option card, and the 190-WiFi option card.

Note that for the indicator to respond to the ASCII commands described below, the internal serial port and the option cards must be set to "Weight-On-Demand" output format.

Request Displayed Weight Command (Scoreboard Format)

The wireless device sends:

<ENQ> (hex 05)

The 190 will respond with weight in Cardinal Scoreboard format:

<S><XXXXXX><d>_<UU>_<m>_<cc>_<CR>

where:

- <S>** = sign
 - "-" = negative
 - space = positive
- <XXXXXX>** = weight (six digits)
- <d>** = decimal point (embedded in weight, if enabled in setup)
- _** = space
- <UU>** = units of measure ("LB", "OZ", "KG", or "G ")
- <m>** = mode
 - G = gross
 - N = net
- <cc>** = weight status
 - OC = over capacity
 - CZ = center of zero
 - MO = unstable
 - EE = weight is not being displayed
 - " " = none of the above
- <CR>** = carriage return (hex 0D)

Request Displayed Weight Command (SMA Format)

The wireless device sends:

<LF>W<CR>

The 190 will respond with displayed weight in SMA format:

<LF><s><r><n><m><f><xxxxxxx.xxx><uuu><CR>

where:

<LF> = line feed (hex 0A)

<s> = scale status

Z = center of zero

O = over capacity

U = under capacity

E = zero error

T = tare error

e = weight is not being displayed

space = none of the above

NOTE: For the E or T error conditions, <xxxxxxx.xxx> = -----

<r> = range (always 1)

<n> = mode

G = gross

T = tare

N = net

<m> = motion status

M = unstable

space = stable

<f> = always a space

<xxxxxxx.xxx> = weight (fixed at ten characters)

>

<uuu> = units of measure ("lb", "oz", "kg", or "g")

<CR> = carriage return (hex 0D)

Request Scale to Zero Command

The wireless device sends:

<LF>Z<CR>

The 190 will attempt to zero the scale and respond with weight in SMA format. Scale status will indicate if the attempt to zero was unsuccessful.

Request Scale to Tare Command

The wireless device sends:

<LF>T<CR>

The 190 will attempt to set the tare to current gross weight and respond with displayed weight in SMA format. Scale status will indicate if the attempt to tare was unsuccessful. Setting the tare will change the displayed weight to net mode.

Return Tare Weight Command

The wireless device sends:

<LF>M<CR>

The 190 will respond with the tare weight in SMA format.

Clear Scale Tare Weight Command

The wireless device sends:

<LF>C<CR>

The 190 will clear the tare weight and respond with displayed weight in SMA format. Clearing the tare will change the displayed weight to gross mode.

Repeat Displayed Weight Continuously Command

The wireless device sends:

<LF>R<CR>

The 190 will repeat displayed weight in SMA format continuously until another SMA command is received.

About Scale First Line Command

The wireless device sends:

<LF>A<CR>

The 190 will respond with:

<LF>SMA:2/1.0<CR>

About Scale Scroll Command

The wireless device sends:

<LF>B<CR>

The 190 will respond with the following (**NOTE:** The command must be repeated for each response):

<LF>MFG:Cardinal Scale Mfg. Co.<CR>

<LF>MOD:190<CR>

<LF>REV:n.n.nn/1.1<CR>

<LF>END:<CR>

NOTE: n.n.nn will be the version number for the 190 firmware.

Scale Information Command

The wireless device sends:

<LF>I<CR>

The 190 will respond with:

<LF>SMA:2/1.0<CR>

Scale Information Scroll Command

The wireless device sends:

<LF>N<CR>

The 190 will respond with the following:*

<LF>TYP:S<CR>

<LF>CAP:uuu:ccc:n:d<CR>

<LF>CMD:TMCIN<CR>

<LF>END:<CR>

The **CAP** response will be repeated once for each unit of measure.

uuu is the unit of measure.

ccc the capacity for that unit of measure.

n is the least significant count by digit (e.g., 1, 2, 5, 10, 20, ...).

d is the decimal point position (0=none, 1=xxxxx.x, 2=xxxx.xx, 3=xxx.xxx).

***NOTE:** the command must be repeated for each response.

Invoke Scale Diagnostics Command

The wireless device sends:

<LF>D<CR>

The 190 will respond with diagnostic status:

<LF><r><e><c><m><CR>

where:

- <LF>** = line feed (hex 0A)
- <r>** = space
- <e>** = space
- <c>** = 'C' = calibration error, space = OK
- <m>** = space
- <CR>** = carriage return (hex 0D)

Abort Command

The wireless device sends:

<ESC> (hex 1B)

The 190 will clear any pending commands. The 190 will not send a response to this command.

Unrecognized Command Response

If the 190 receives a command it does not recognize it will respond with

<LF>?<CR>

ERROR MESSAGES

Before You Call Service

The Cardinal 190 Weight Indicator has been designed to provide you with years of trouble-free operation. However, should you experience a problem, please refer to the troubleshooting guide below before you call for service. The following describes several types of symptoms along with suggested remedies.

PROBLEM	POSSIBLE SOLUTIONS
The display does not turn on	<p>AC operation:</p> <p>Is the AC power cord fully inserted into the wall receptacle? Check the wall receptacle for proper AC power. Try another electrical appliance in the same receptacle, does it work? Check the circuit breaker. Has there been a power failure?</p> <p>Battery operation:</p> <p>Check if the battery is installed correctly. Is the battery discharged? Replace or recharge.</p>
Incorrect weight displayed	<p>Has the indicator been calibrated? Ensure that the scale platform isn't touching an adjacent object. Check the load cell connector wiring. If using four (4) wire load cells, ensure the sense lead jumpers (J4 & J5) are installed. Have proper operation procedures been followed?</p>
The indicator will not display weight	<p>Refer to the Error Codes section and make certain that the "oCAP" message is not displayed. If so, and the scale is not loaded, perform the calibration procedure.</p>
The printer prints but does not use the Print Tab Settings or prints a test ticket	<p>The print tab setting or visual ticket format must be selected before beginning the weighing operation or just before printing the ticket.</p> <p>To select the ticket format before beginning the weighing operation:</p> <ol style="list-style-type: none"> 1. Press the Fn/▲ key then the PRINT key. The display will change to the "P r t =". 2. Press the TARE ↵ key to show the current value. 3. If the value displayed is acceptable, press the TARE ↵ key again to save it. 4. If the displayed value is incorrect (or another ticket format is desired), use the Fn/▲ key to toggle to a new setting and press the TARE ↵ key to save it. <p>Allowable values for ticket formats are:</p> <p style="padding-left: 40px;">0 = print tab settings 1 = visual ticket format</p> <p>NOTE: When a print format is selected, it will remain active until changed by the operator.</p>

Error Codes

The Cardinal 190 Weight Indicator is equipped with software that indicates when an error in the operation takes place. The following lists the error codes displayed by the 190 along with their meaning. Should you encounter an error code, please refer to this list for the cause.

Error	Cause (A.) and Corrective Action (B.)
<i>CONF 19</i>	<p>A. Calibration required.</p> <p>B. Calibrate the scale with test weights.</p>
<i>ERRRH</i>	<p>A. The analog input is off the scale at the upper end of the input range.</p> <p>B. Check wiring and load cell.</p>
<i>ERRRL</i>	<p>A. The analog input is off the scale at the lower end of the input range.</p> <p>B. Check wiring and load cell.</p>
<i>Error</i>	<p>A. Attempt to perform an illegal function:</p> <ol style="list-style-type: none"> 1. Performing a hold operation when the weight is invalid (e.g., overcapacity). 2. Attempting to clear Tare with Gross weight greater than zero (<i>LFt = 1</i>, <i>OSR = 0</i>). 3. Attempting to zero the scale when there is motion present or the scale is over capacity. 4. Attempting to zero the scale when Gross weight is out of zero range (<i>ErL = 4E5</i>). 5. Attempting to print when the scale is over capacity. 6. Attempting to do a span adjustment with insufficient load on the scale. 7. Attempting to tare scale when there is motion present or the Gross weight is below zero or over capacity.
<i>Lo bAt</i>	<p>A. This message is used with the battery operation and will turn ON to indicate the battery does not have a sufficient charge and requires recharging. If continued use furthers drains the battery, no change in operation will occur until just before the battery voltage drops to a level where operation is affected. At this level, the indicator will automatically turn off.</p> <p>B. Charge the battery pack or replace it.</p>
<i>notArE</i>	<p>The NET/GROSS key was pressed when there is no stored tare.</p>
<i>oCAP</i>	<p>A. The load on the scale exceeds the capacity of the scale.</p> <p>B. Remove the excess load.</p>
<i>-oF-</i>	<p>A. The indicator is trying to display a positive number with more than six digits or a negative number with more than five digits.</p> <p>B. Return to Gross weight mode and review the Tare weight. Might indicate incorrect calibration.</p>
<i>UnStb</i>	<p>A. Motion was present when a print was initiated.</p> <p>B. Wait for a stable indication before printing.</p>

EVENT COUNTERS

The Cardinal Model 190 Weight Indicator has been designed with a Category 1 Event Counter type of security seal. The 190 will display two event counters that increment when a change is made to features that are required by NTEP or OIML to be sealed. One counter is designated for calibration parameters and one is designated for configuration changes as required in NCWM Publication 14, 2007. Each event counter's data is maintained in non-volatile memory and can be viewed by a Weights and Measures inspector.

The calibration event counter ($\llcorner RL \llcorner$) will be incremented once each time Setup mode is entered and a change is made to at least one calibration parameter (span adjustment, coarse zero adjustment, etc.). Up to 10,000 calibration events can be counted.

The configuration event counter ($\llcorner FG \llcorner$) will be incremented once each time Setup mode is entered and a change is made to at least one configuration parameter. Up to 10,000 configuration events can be counted.

Accessing the Event Counters

1. With the indicator ON, press the **Fn/▲** key and press the **NET/GROSS** key.
2. The display will change to show $\llcorner RL \llcorner$.
3. Press the **TARE** \llcorner key.
4. The display will change to show the current value for the number of times the indicator has been calibrated.
5. Press the **TARE** \llcorner key.
6. The display will change to show $\llcorner FG \llcorner$.
7. Press the **TARE** \llcorner key.
8. The display will change to show the current value for the number of times the indicator has had a configuration change.
9. Press the **TARE** \llcorner key.
10. The indicator will return to the normal weight display.

Configuration Parameters	
<i>USA</i>	Domestic or International
<i>LFT</i>	Legal-For-Trade
<i>Unit 1</i>	Weighing Units 1 (Primary Units)
<i>Int</i>	Interval Setting
<i>dPP</i>	Decimal Point Precision
<i>CAP</i>	Capacity
<i>Unit 2</i>	Weighing Units 2 (Secondary Units)
<i>trR</i>	Zero Tracking Range
<i>trL</i>	4% Zero Limit
<i>PUD</i>	Power Up Zero
<i>dFLT</i>	Digital Filter Number
<i>F</i>	Filter Level Amount
<i>b</i>	Filter Break Range
<i>sr</i>	Sample Rate
<i>UnS</i>	Motion Range
<i>SC</i>	Stable Count

TEST MODE/ DIAGNOSTICS

The Cardinal Model 190 Weight Indicator has a comprehensive diagnostic feature that can allow it to self-diagnose a problem. After displaying the model number, software revision, and performing a display test, the indicator will enter the diagnostics mode.

The diagnostics feature will check to ensure that the internal memory is functioning correctly, that setup parameters (as well as other operational parameters) are within range and that the battery (if equipped with batteries) voltage is correct for operation.

Accessing Test Mode/Diagnostics

To access the Test Mode/Diagnostics feature, with the indicator ON, press the **Fn/▲** key and press the **UNITS/◀** key. Each test lasts about one second.

1. The model number (190) will be displayed
2. The software version (r #.#.#) will be displayed.
3. All horizontal segments will turn on and then off.
4. All vertical segments and decimal points will turn on and then off.
5. The key status arrows will turn on and then off.
6. Each weight mode annunciator (lb, kg, etc.) will turn on and then off.
7. The diagnostics feature will perform an internal memory check, verify that the setup parameters (and other operational parameters) are within range and if equipped with batteries, that the voltage is correct for operation.
8. *SETUP:-* and *PASS* will be displayed if everything passes the diagnostic check.
9. The calibration numbers (C1 to C4) will be displayed.

PARTS IDENTIFICATION

Front Sub-Assembly

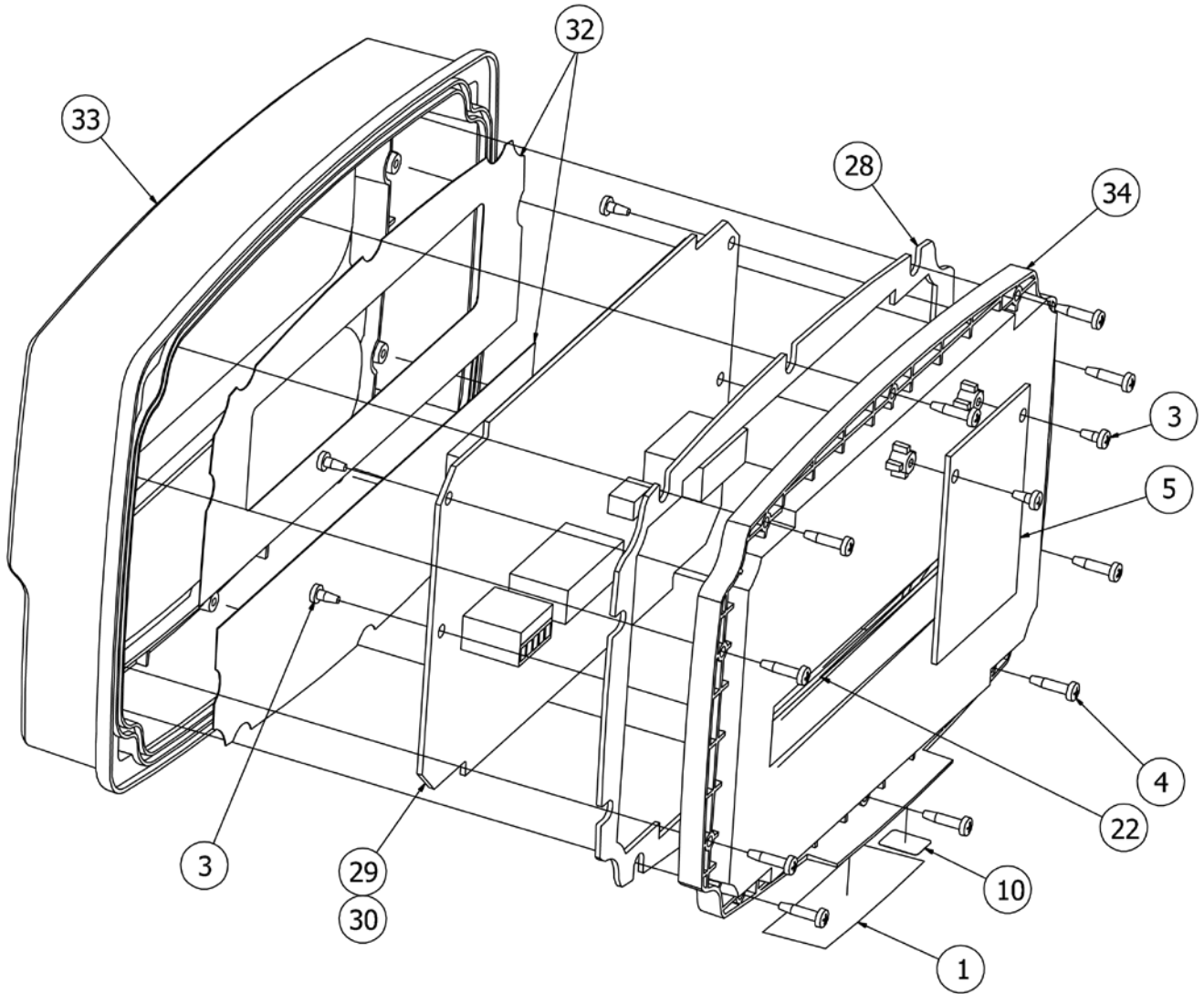

Front Sub-Assembly, Cont.

ITEM NO.	QTY.	PART NUMBER	DESCRIPTION
1	1	593GR986	SERIAL TAG ASSY
3	8	6021-1286	SCW PAN-HEAD PLASTIC THD. ROLLING, #4X1/4, PHIL. DR. Z/P
4	10	6021-1287	SCW PAN-HEAD PLASTIC THD. ROLLING, #4X1/2, PHIL. DR. Z/P
5	1	SEE LIST BELOW	PCB, 190 OPTION CARDS
10	1	6600-0659	LABEL "WEEE" .4" X .5" (WHITE ON BLACK)
22	1	8400-B014-08	CONNECTOR GASKET, 190
28	1	8400-C013-08	CENTER GASKET, 190
29	1	8400-D003-0A	PCB ASSY 190 CONTROLLER
30	1	8400-D003-1A	PCB ASSY 190EU CONTROLLER
32	1	8400-D008-08	190 OVERLAY
33	1	8400-D010-08	PLASTIC FRONT, 190
34	1	8400-D011-08	PLASTIC CENTER, 190

190 OPTION CARDS

190-DAC, 190-IP, 190-RS232, 190-USB, and 190-WIFI

PCB Controller Terminal Block Connectors*

QTY.	PART NUMBER	DESCRIPTION
1	6610-1552	P2 – 5-PIN POWER TERMINAL BLOCK CONNECTOR
1	6610-1554	P5 – 7-PIN LOAD CELL TERMINAL BLOCK CONNECTOR
1	6610-1556	P3 – 9-PIN I/O TERMINAL BLOCK CONNECTOR

* Not shown.

Rear Sub-Assembly

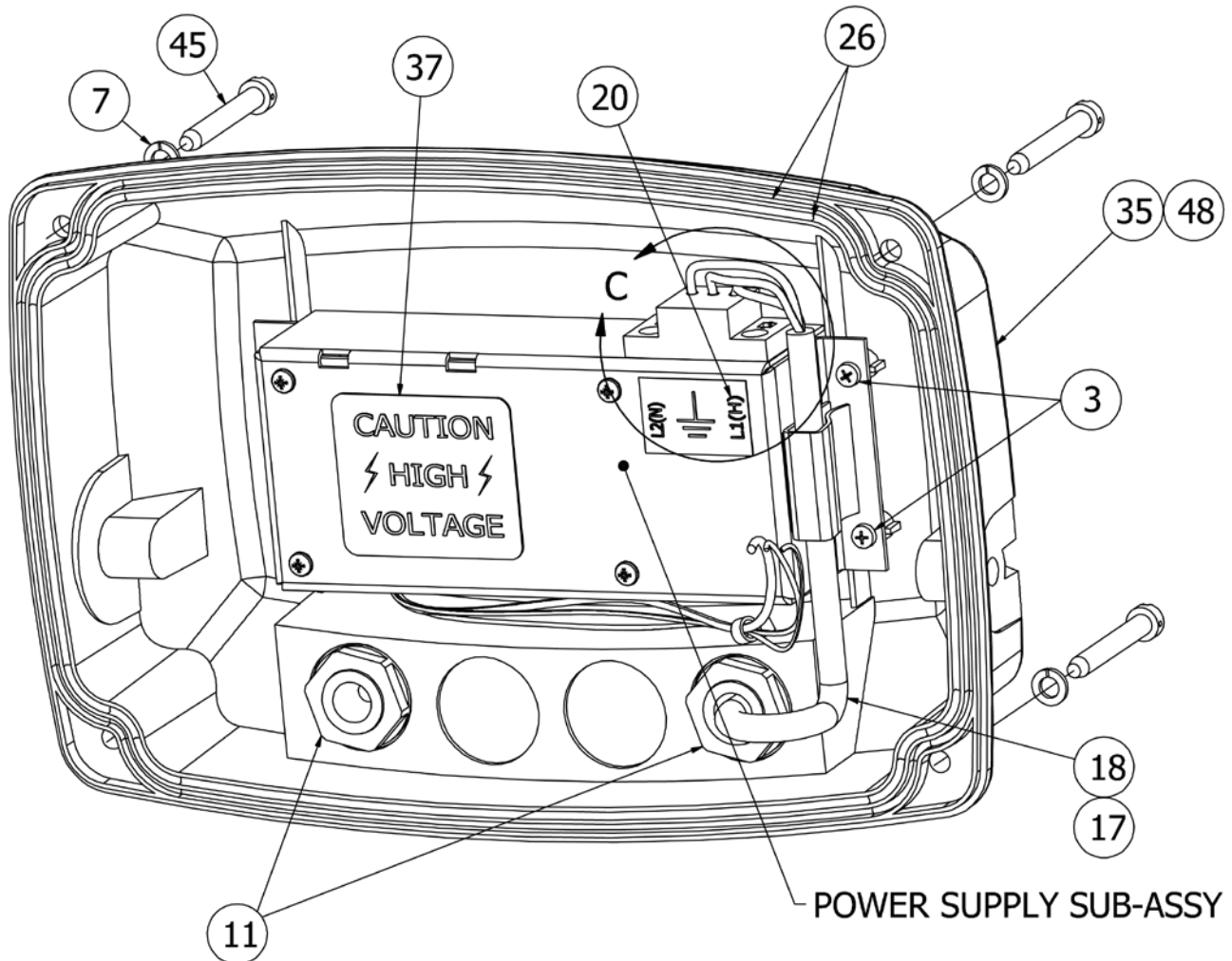

ITEM NO.	QTY.	PART NUMBER	DESCRIPTION
3	8	6021-1286	SCW PAN-HEAD PLASTIC THD. ROLLING, #4X1/4, PHIL. DR. Z/P
7	4	6024-0037	WASHER LOCK HELICAL SP #10 REG SS
11	2	6610-2248	CONN GLAND .187-.312 GRIP .599 MTG BLK
17	1	6980-0250	POWER CORD H05VV-F3G 1mm, 10A/250V, EURO PLUG
18	1	6980-1030	POWER CORD 18/3 SVT CEE 6.3 FT
20	1	8200-B104-08	LABEL: 205-210 TERM. BLOCK
26	2	8400-B020-08	O-RING, 190
35	1	8400-D012-08	PLASTIC BACK, 190
37	1	8510-C346-0I	LABEL CAUTION HIGH VOLTAGE
45	4	8400-0150-08	SCW FILLISTER, MACHINE-SCW 10-32X1.5. WITH UNDERCUT THREADS SS
48	1	8400-D012-08	MODIFIED PLASTIC BACK, 190 (FOR 190A)

Rear Sub-Assembly, Cont.

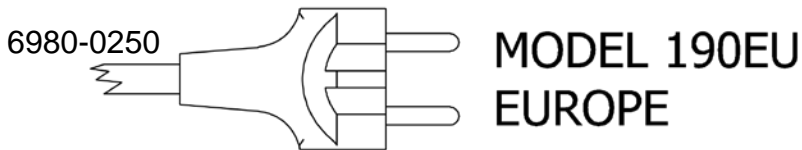
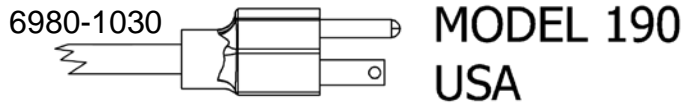
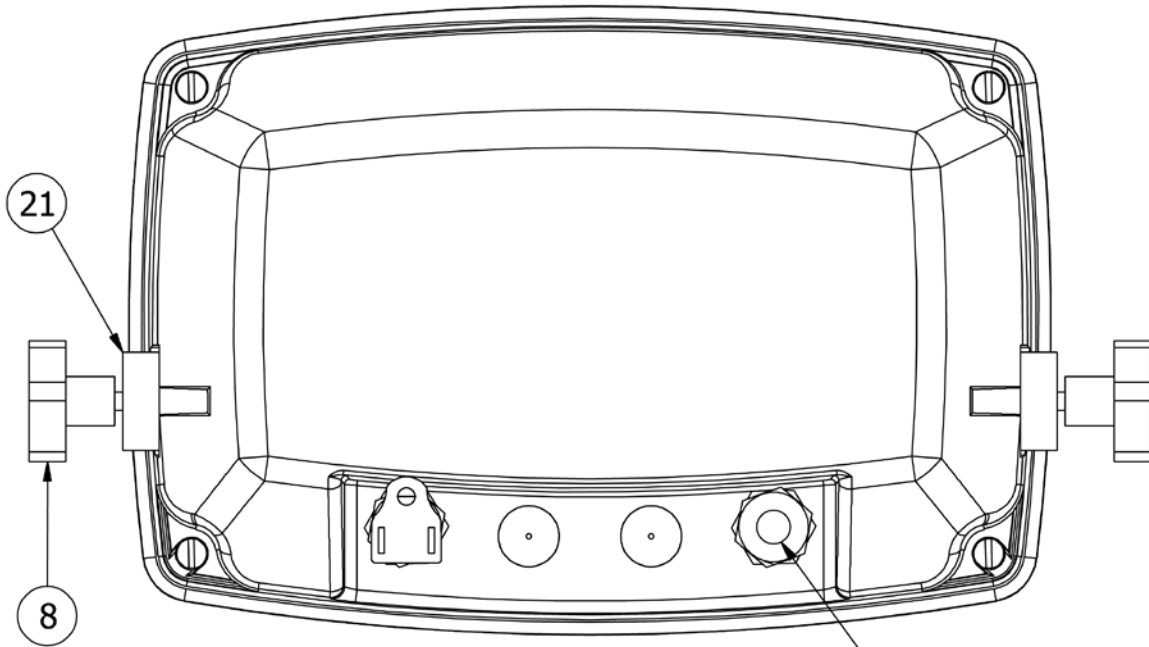

ITEM NO.	QTY.	PART NUMBER	DESCRIPTION
8	2	6540-0332	KNOB, ENCLOSURE 1.25 DIA W/10-32 X 3/4 STUD
9	1	6540-1104	PLUG, HOLE 0.343" X 0.187" X 1" LG, SILICONE RUBBER
21	2	8400-B001-08	RUBBER GIMBAL WASHER

AC Wiring (Detail C)

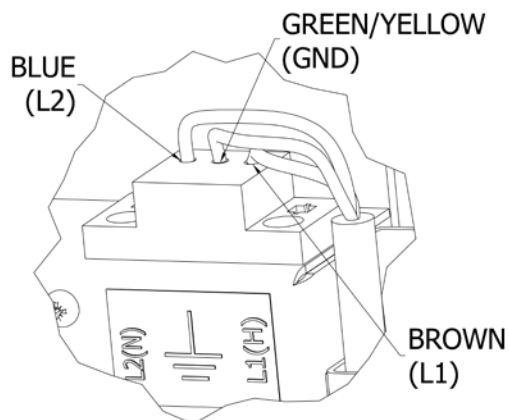

Power Supply Sub-Assembly

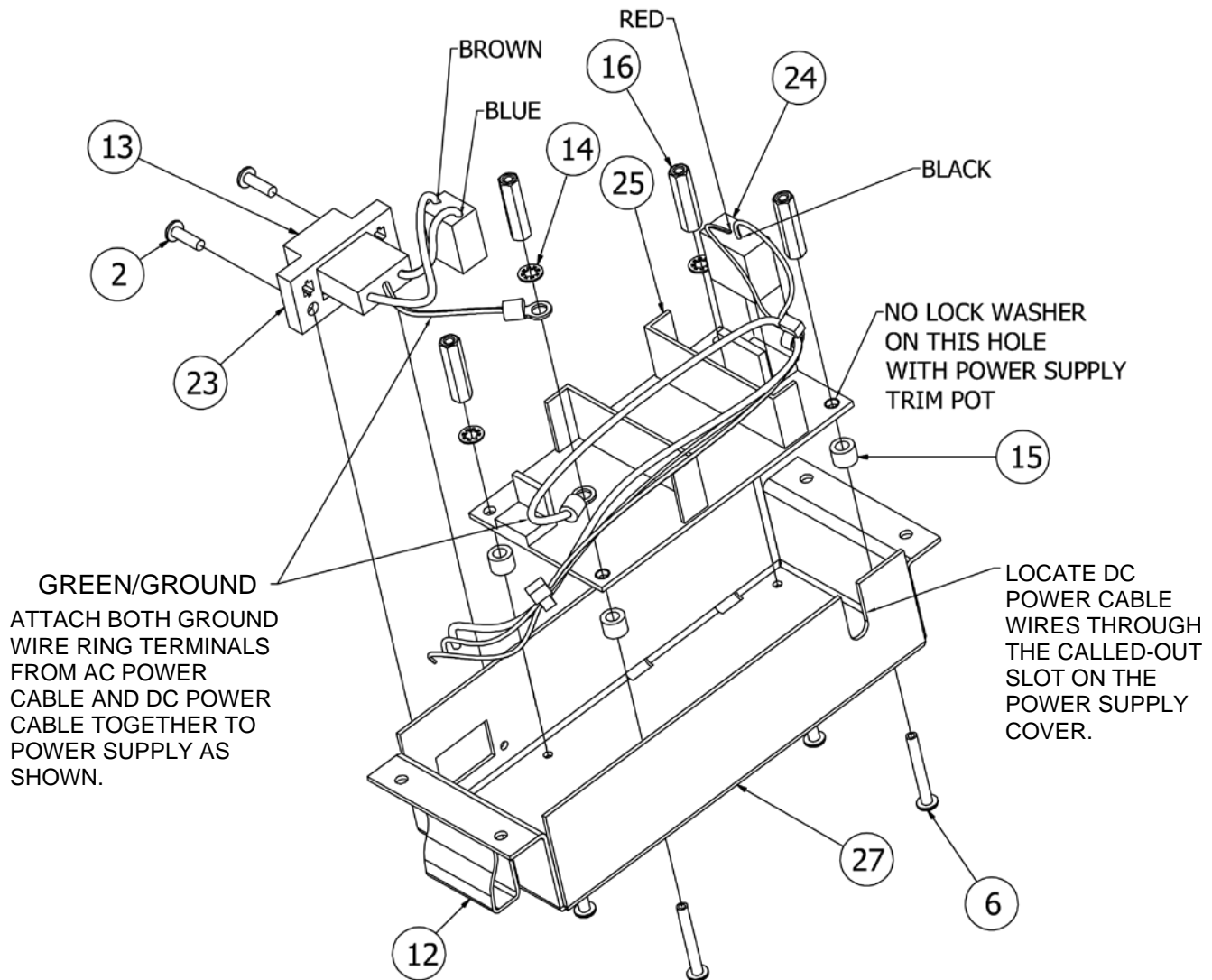

ITEM NO.	QTY.	PART NUMBER	DESCRIPTION
2	2	6021-0423	SCW ROUND-HEAD, MACHINE-SCW 04-40X.250
6	4	6021-2018	SCW PAN-HEAD, MACHINE-SCW 04-40X.875
12	1	6610-5007	CABLE CLIP, 1" X 1" GREY
13	1	6610-5084	TERMINAL BLOCK 3 POS. 5MM PLUGGABLE RT-AN
14	3	6680-0026	WASHER LOCK INT TOOTH #4 TYPE A Z-PL
15	4	6680-0138	SPACER #6 X .187 NYLON
16	4	6680-1107	SPACER #4-40 X .750 3/16 HEX ALU. Z/P
23	1	8400-B017-0A	190 AC POWER CABLE (SEE AC WIRING DETAIL C)
24	1	8400-B018-0A	DC POWER CABLE, 190
25	1	8400-B019-08	POWER SUPPLY, 190
27	1	8400-C005-08	POWER SUPPLY COVER, 190

P2 Wiring Detail

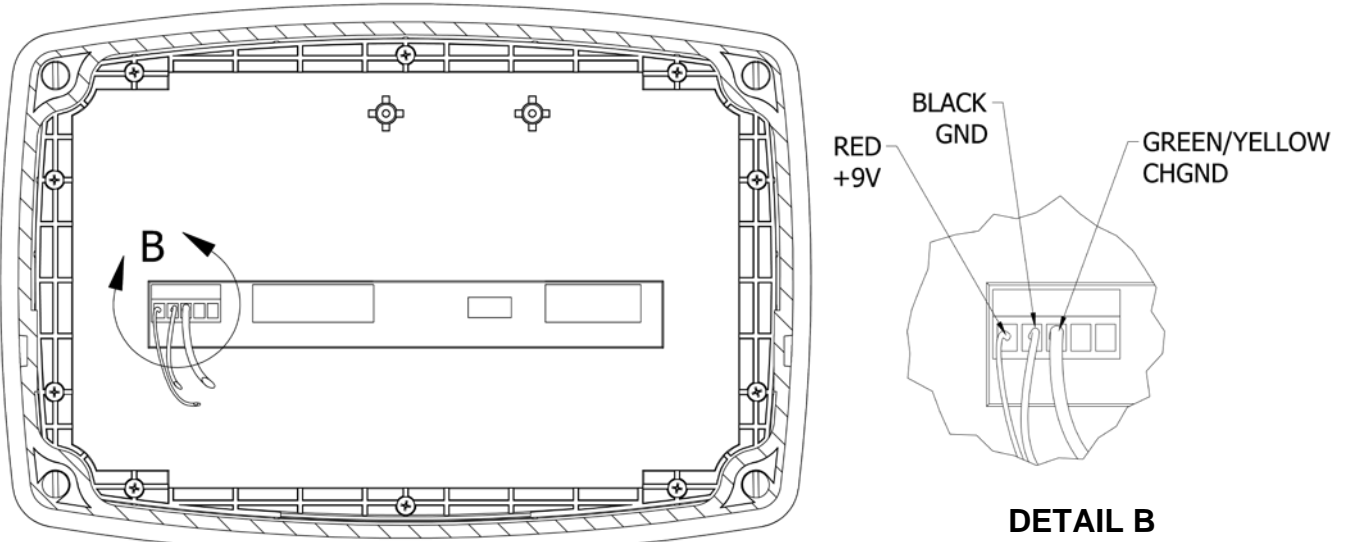

P2 Wiring Detail with 190-DAC Option Card

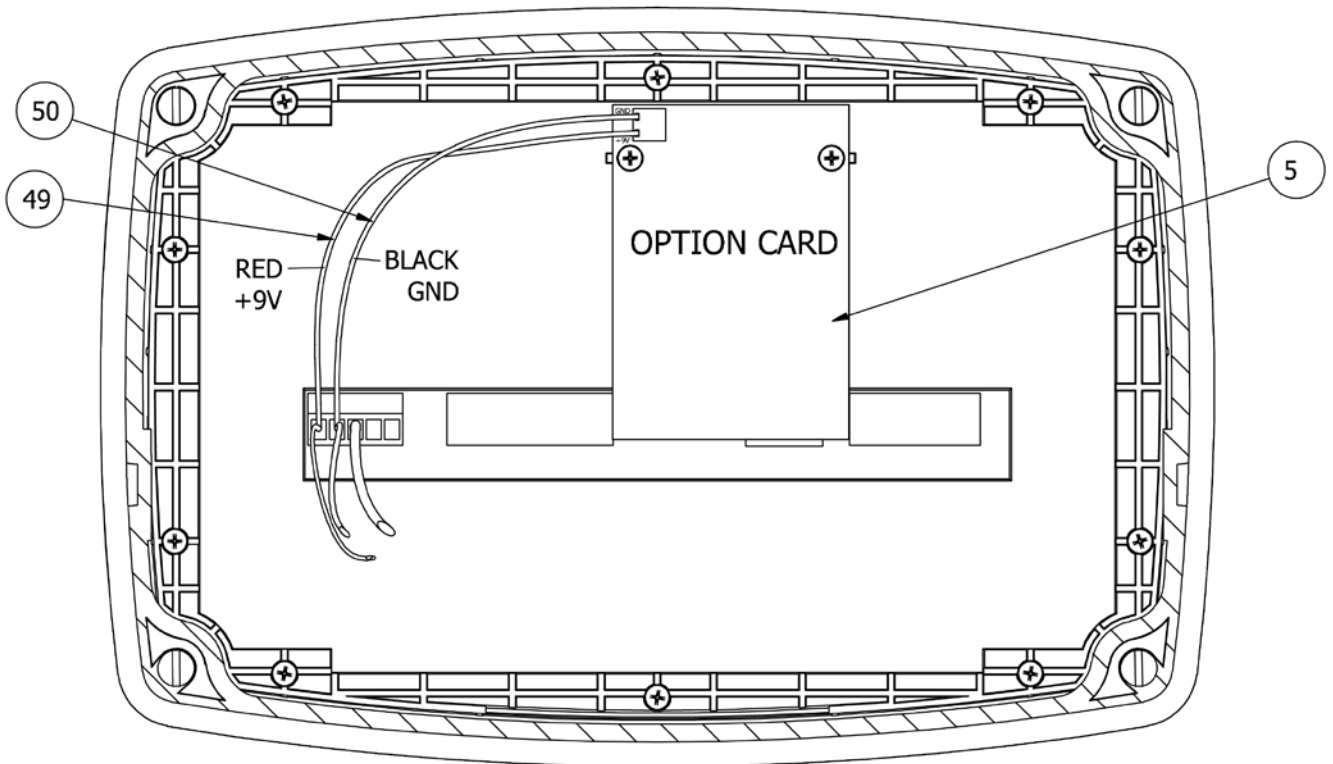

ITEM NO.	QTY.	PART NUMBER	DESCRIPTION
5	1	8400-C031-0A	PCB, 190-DAC OPTION CARD
49	0.5 ft	6980-0151	WIRE, 24 GA, RED (6" LONG)
50	0.5 ft	6980-0150	WIRE, 24 GA, BLACK (6" LONG)

190DC and 190LS Rear Sub-Assembly

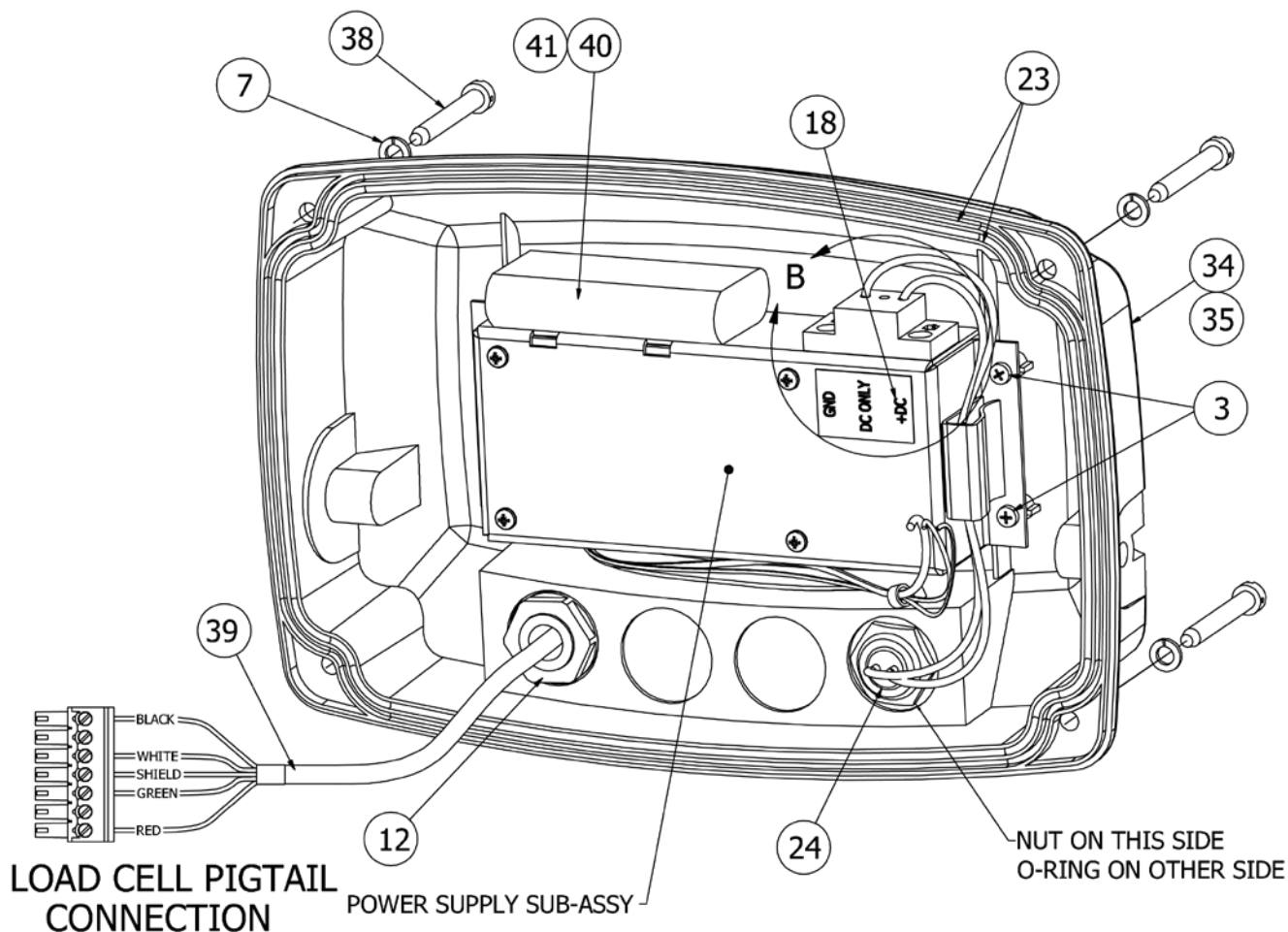

ITEM NO.	QTY.	PART NUMBER	DESCRIPTION
3	8	6021-1286	SCW PAN-HEAD PLASTIC THD. ROLLING, #4x1/4, PHIL. DR. Z/P
7	4	6024-0037	WASHER LOCK HELICAL SP #10 REG SS
12	1	6610-2248	CONN GLAND .187-.312 GRIP .599 MTG BLK
18	1	8200-B567-08	LABEL: 825-DCPOWER
23	2	8400-B020-08	O-RING, 190
24	1	8400-B025-0A	CABLE ASSY: 190DC 2-PIN CONN.
34	1	8400-D012-08	PLASTIC BACK, 190
35	1	8400-D012-18	MODIFIED PLASTIC BACK, 190 (FOR 190A)
38	4	8400-0150-08	SCW FILLISTER, MACHINE-SCW 10-32X1.5, WITH UNDERCUT THREADS SS
39	1	1938-0050-0A	CABLE, 190 LOAD CELL PIGTAIL (190LS ONLY)
40	2	6610-5033	CABLE TIE, LARGE 8" (190LS ONLY)
41	1	6800-1072	BATTERY, LI-ION, 7.4V, 2600 mA (190LS ONLY)

190DC Power Supply Sub-Assembly

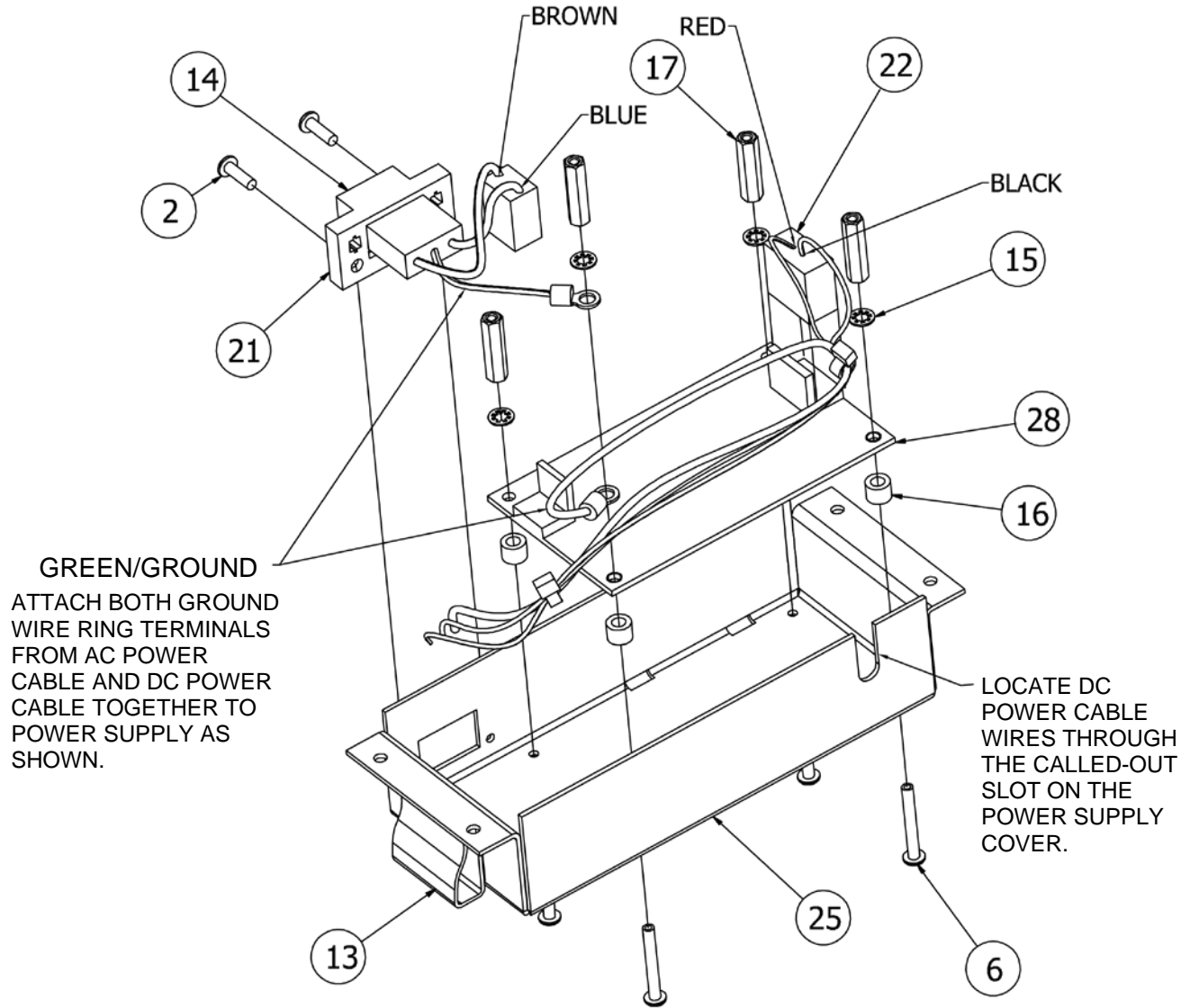

ITEM NO.	QTY.	PART NUMBER	DESCRIPTION
2	2	6021-0420	SCW ROUND-HEAD MACHINE-SCW 04-40X.375
6	4	6021-2018	SCW PAN-HEAD, MACHINE-SCW 04-40X.875
13	1	6610-5007	CABLE CLIP, 1" X 1" GREY
14	1	6610-5084	TERMINAL BLOCK 3 POS. 5MM PLUGGABLE RT-AN
15	4	6680-0026	WASHER LOCK INT TOOTH #4 TYPE A Z-PL
16	4	6680-0138	SPACER #6 X .187 NYLON
17	4	6680-1107	SPACER #4-40X.750 3/16 HEX ALU. Z/P
21	1	8400-B017-0A	190 AC POWER CABLE (SEE 190DC WIRING DETAIL B)
22	1	8400-B018-0A	DC POWER CABLE, 190
25	1	8400-C005-08	POWER SUPPLY COVER, 190
28	1	8400-C026-0A	POWER SUPPLY, 190DC

190DC Wiring Detail B

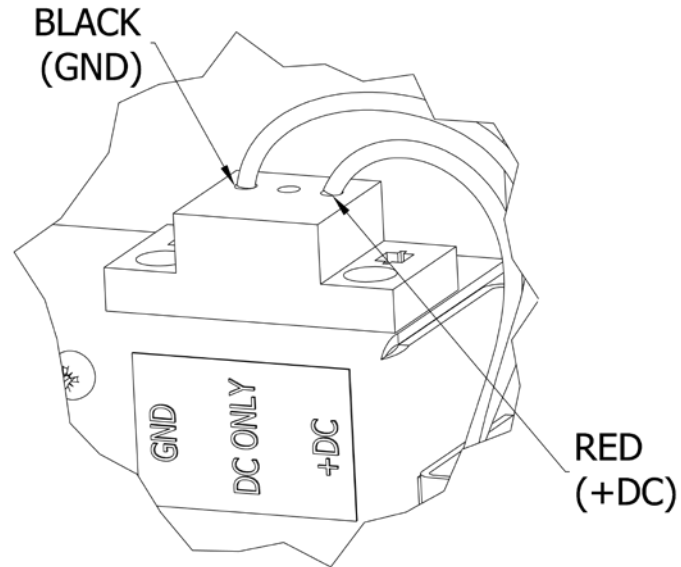

190DC POWER OPTIONS (not shown)

(Must select from power options listed below)

PS190	190DC POWER MATING CONNECTOR ATTACHED AC ADAPTER WITH US, UK, AND EU PLUGS
190DC6	190DC POWER MATING CONNECTOR, 6 FT CABLE AND BATTERY TERMINAL EYELETS
190DC12	190DC POWER MATING CONNECTOR, 12 FT CABLE AND BATTERY TERMINAL EYELETS
190DC18	190DC POWER MATING CONNECTOR, 18 FT CABLE AND BATTERY TERMINAL EYELETS
190DCMATE	190DC POWER MATING CONNECTOR

APPENDIX A – BP190 OPTIONAL BATTERY PACK

BP190 Contents:

QTY	PART NUMBER	DESCRIPTION
2	6610-5033	CABLE TIE LARGE 8" SST2SM
1	6800-1072	BATTERY PACK LI-ION 7.2V, 2600 mAh 6" LEADS

BP190 Specifications:

DISCHARGE CURRENTS

Backlight	# of Cells	Current ~ Continuous Operation
Indicator turned off:		2.2mA ~ 1150hrs [*]
No backlight	1 @ 350Ω	27.5mA ~ 92hrs
Blue Backlight	1 @ 350Ω	30.75mA ~ 83hrs
Red Backlight	1 @ 350Ω	53.3mA ~ 48hrs
Green Backlight	1 @ 350Ω	56.2mA ~ 45hrs
Yellow Backlight	1 @ 350Ω	62.7mA ~ 41hrs
Blue Backlight	4 @ 350Ω	77.8mA ~ 33hrs
Blue Backlight	6 @ 350Ω	105mA ~ 24hrs

* Ambient temp will change this quite a bit

CHARGING

To recharge the battery pack, the AC power adapter must be connected to an AC power outlet and plugged into the indicator. It will take approximately six (6) hours to fully recharge the battery pack in the indicator. While the battery pack is charging the indicator can still be operated. **NOTE:** Charging the battery pack for more than six (6) hours *will not* damage it.

CHARGING GUIDELINES

- **DO NOT** charge battery below freezing.
- **DO NOT** charge the battery above 40 C.
- Lithium-ion does not need to be fully charged; a partial charge is acceptable.
- The battery does not need to be fully discharged between charging cycles.

Installing the BP190

1. Loosen the 4 Captive screws securing the rear housing to the front housing assembly.
2. Remove 5-connector terminal block from P2 on 190 main board.
3. Referring to labels on the circuit board for terminal connections, connect each wire to the terminal block.
4. To terminate a wire, loosen the screws in the terminal block and then insert the wire into the terminal opening. Tighten the screw to secure the wire in place. Repeat the procedure until both wires are in place.

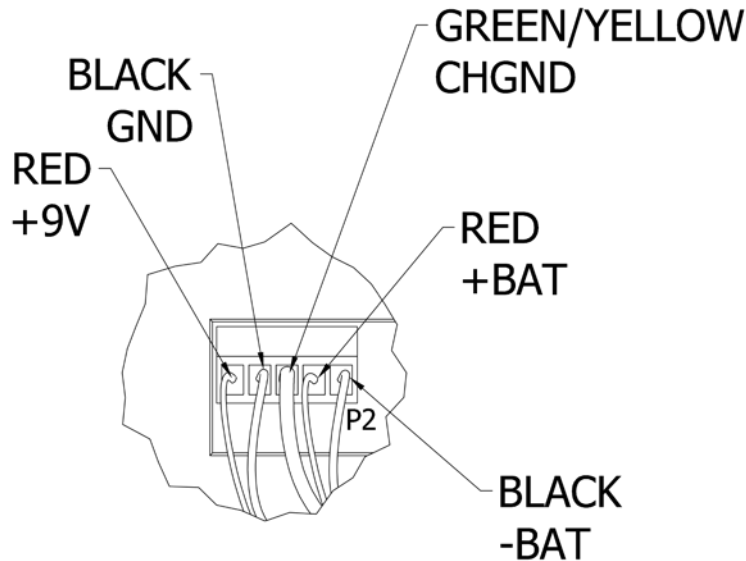

5. Insert two (2) cable ties through the slots in the power supply cover as shown on the next page.



NOTE: If your power supply cover does not have two (2) slots, connect two (2) cable ties together and secure the battery by sliding cable tie behind power supply cover and over battery pack as shown on the next page. *Make sure the cable tie connections are on the top of the batteries and not the front of the batteries.*

6. Place the battery pack on the power supply cover.
7. Secure battery pack to power supply cover with cable ties.
8. Insert 5-connector terminal block removed in step 2 into P2 on 190 main board.
9. Make certain no cables or wires are exposed between the rear housing and front housing assembly and then place the front housing assembly onto the rear housing.
10. Secure by tightening the 4 Captive screws loosened earlier. The indicator is ready for normal operations.

Slots in Power Supply Cover

Cable Ties

Battery Pack

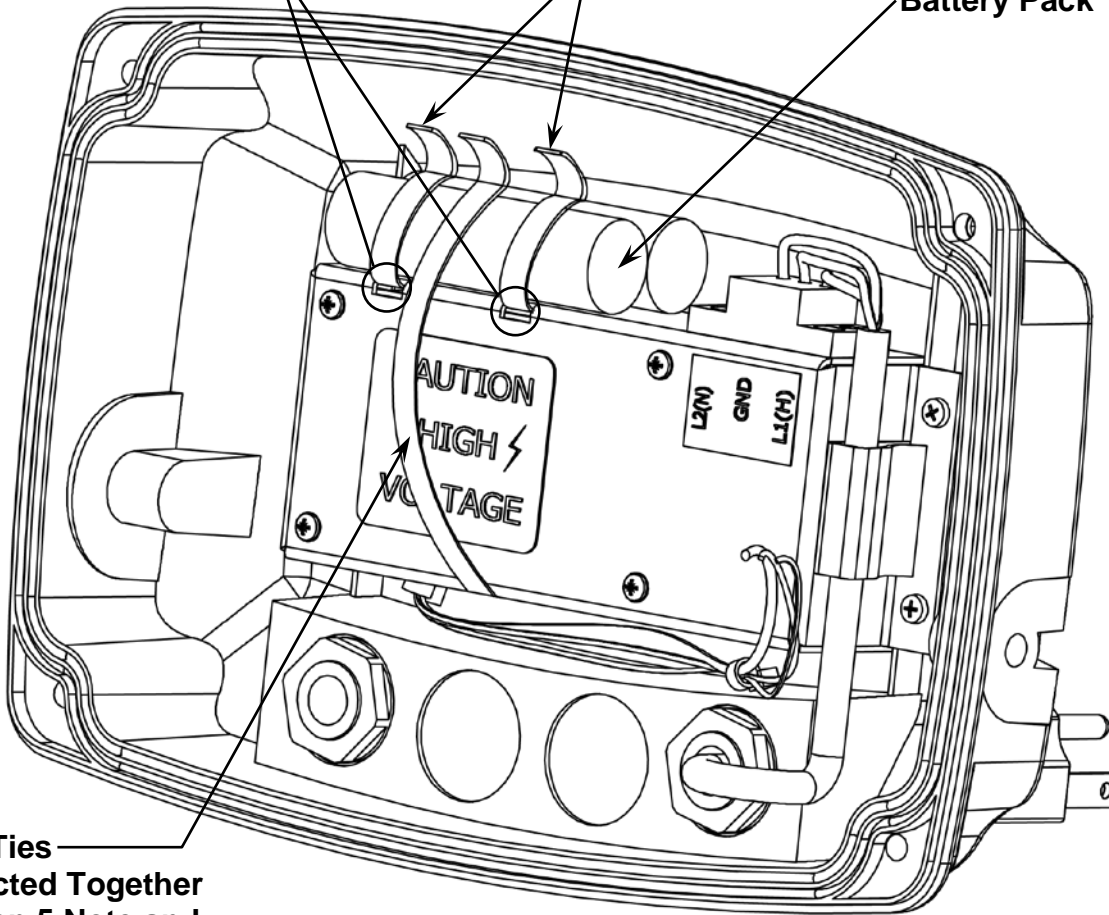

Cable Ties Connected Together See Step 5 Note and Images Below.



CORRECT!
Position Cable Ties Connection on Top of Batteries.



WRONG!
Do Not Position Cable Ties Connection on Front of Batteries.

APPENDIX B – Model 190A

Designed for non-legal-for-trade portable axle weighing applications such as with Cardinal's CWL-40 and 760 series mobile wheel weighers, the Model 190A weight indicator features axle weighing software, traffic control mode to automatically capture accumulative axle weights without the driver having to leave the truck (when connected to an SB500 remote display and printer), two RS232 serial ports (for printer and remote display), optional rechargeable lithium-ion battery, capacitive touch keys, and IP69K-rated wash down enclosure (the highest protection rating possible). The 190A features 3 watertight gland connectors, a quick-connect power connector, and one ID.

Traffic Control

Traffic control is available when the 190A is used with an SB500 scoreboard with a traffic light. The SB500 is selected by setting the Continuous Output format type for the serial port to 2.

After the SB500 has been selected, a prompt for threshold weight will be displayed `THR 5 :`. If the threshold is set to 0, then traffic control will be disabled. Otherwise, the threshold weight will determine whether the traffic light is red or green.

When the scale gross weight is less than or equal to the threshold weight, the traffic light will be green. When the scale gross weight is larger than the threshold weight, the traffic light will change to red. The light will stay red until the scale gross weight is less than or equal to the threshold weight or a ticket is printed.

If a ticket is printed, the light will change to green. It will remain green until the scale gross weight goes below and then above the threshold weight again. Then the light will change to red.

Axle Weighing Mode

Setup

Axle weighing mode is enabled by setting the `d out :` parameter to 5, setting the `Auto :` parameter to determine whether the scale will be an automatic axle weigher or will function as a standard axle weigher, setting the printer `Port` number to 1 or 2, and setting the continuous output `Cont` on the selected port to NO.

`d out :` X,Y (Digital Output)

5 = setting enables the Axle Weighing Mode.



NOTE: The Model 190 cannot be upgraded to a Model 190A in the field. It must be returned to the factory to perform the upgrade.

When the `d out :` parameter is set to 5, the following prompts will be enabled:

RUt o = (Automatic Axle Weigher)

The *RUt o* = (Automatic Axle Weigher) prompt determines whether the scale will be an automatic axle weigher or will function as a standard axle weigher, using the **PRINT / Fn PRINT** key functions

Press the **TARE** \leftarrow key to show the current setting. If the setting displayed is acceptable, press the **TARE** \leftarrow key again to save it. Otherwise, use the **Fn/▲** key to toggle to a new setting and press the **TARE** \leftarrow key to save it.

RUt o = *YES*

The scale will be an
automatic axle weigher

RUt o = *no*

The scale will be a
standard axle weigher

When *RUt o* = *YES*, the following additional prompts will be displayed.

t H r S = (Threshold Weight)

The user can enter a one-to-six-digit number. This value will be the threshold weight or trip point above which the system will consider a truck to be on the scale.

Press the **TARE** \leftarrow key to show the current setting. If the setting displayed is acceptable, press the **TARE** \leftarrow key again to save it. Otherwise, use the **Fn/▲** and **UNITS/◀** keys to enter a new setting and press the **TARE** \leftarrow key to save it. Allowable values for threshold weight are 1 through 999,999.

S d L Y = (Stoplight Delay)

This value is the number of seconds the stop light will stay on (red) before turning back to green following a printing, to allow the user to proceed to the next axle.

Press the **TARE** \leftarrow key to show the current setting. If the setting displayed is acceptable, press the **TARE** \leftarrow key again to save it. Otherwise, use the **Fn/▲** and **UNITS/◀** keys to enter a new setting and press the **TARE** \leftarrow key to save it. Allowable values for the stoplight delay are 1 to 99 seconds.

t d L Y = (Total Delay)

This value is the number of seconds between when the scale weight falls below *t H r S* (threshold weight) and the automatic TOTAL print starts.

Press the **TARE** \leftarrow key to show the current setting. If the setting displayed is acceptable, press the **TARE** \leftarrow key again to save it. Otherwise, use the **Fn/▲** and **UNITS/◀** keys to enter a new setting and press the **TARE** \leftarrow key to save it. Allowable values for the total delay are 1 to 99 seconds.



NOTE: The Total Delay timer will start after the Stoplight Delay timer expires.



IMPORTANT! The following prompt, `id=` (ID Prompt) is displayed after the `touch=` (Key Touch Sensitivity) parameter ONLY in the Model 190A.

`id=` (ID Prompt)

The `id=` (ID=) parameter enables an ID prompt to be displayed when the PRINT key is pressed and printed a ticket.

Press the **TARE** \leftarrow key to show the current setting. If the setting displayed is acceptable, press the **TARE** \leftarrow key again to save it. Otherwise, use the **Fn/▲** key to toggle to a new setting and press the **TARE** \leftarrow key to save it. Allowable values are:

`id=YES`

ID prompt will be displayed when **PRINT** key is pressed and printed on the ticket.

`id=NO`

Normal print operation (no ID prompt) will occur.

Standard Axle Weighing Operation

After placing the wheel load weighers on the ground in front of the steering axle, the two weighers are connected together using the interconnection cable assembly. One weigher (makes no difference which) is connected to the indicator using the indicator interface cable. The interconnection diagram is shown below:

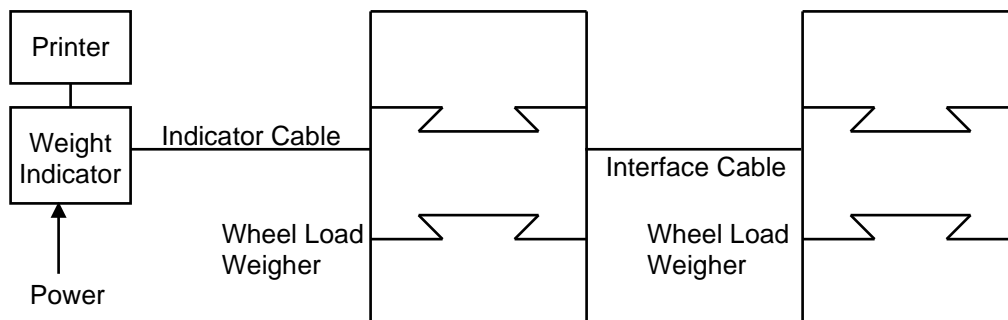

1. Power the indicator on.
2. If the weight display is not 0, press the **ZERO** key.
3. Have the vehicle driven onto the axle load weighers until each wheel is centered on the respective axle load weigher.
4. The axle weight will be displayed on the indicator.
5. When the display shows that the weight is stable, press the **PRINT** key to record the weight.
6. Have the vehicle driven forward until the next set of wheels are centered on the axle load weighers.
7. Press the **PRINT** key to record the weight.

8. Alternatively, to get the total weight of a group of axles, press the **Fn/▲** key.
9. The display will show *g-r P =*.
10. Press the **TARE/Enter** key and the number 0 will be displayed.
11. Press the **Fn/▲** key until the number of axles in the group is displayed.
12. Press the **PRINT** key to record the weight of the first axle.
13. Have the vehicle driven forward until the next set of wheels are centered on the axle load weighers.
14. Press the **PRINT** key.
15. Repeat the process for the remaining axles.
16. After the last axle of the group, the total weight of the axles in the group will be printed.
17. After the last axle has been weighed, press the **Fn/▲** key.
18. The display will show *g-r P =*.
19. Press the **TARE/Enter** key and the number 0 will be displayed.
20. Press the **PRINT** key and the total of the axle weights will be printed and displayed on the weight indicator. The example below illustrates a typical print ticket for a five-axle truck.

Standard Axle Weighing Ticket Format

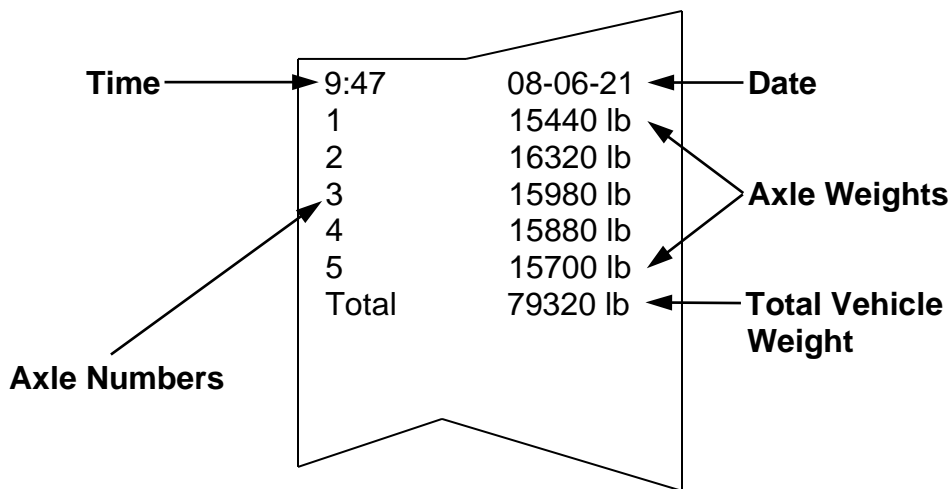

If the preceding steps are repeated, a summary print of the printed record for the vehicle will be produced.

This may be repeated as many times as desired as long as the indicator is not turned off or another axle weight recorded.

As soon as the first axle weight of the next vehicle is printed, the axle weights of the previous vehicle are cleared.

Auto Axle Weighing Operation

1. In the idle state, the light will be green and the system will wait for a truck to approach
2. The first axle is driven on the scale and the weight exceeds t_{HrS} , the threshold weight. The traffic light will turn red. The Gross weight for that axle will be displayed.
3. After the motion on the scale stops, the printer will print the weight on the scale and add the weight to the total accumulator. The *Printed* message will be displayed on the 190 display.
4. After the s_{dLg} (Stoplight Delay) timer runs out the light will turn green. At this time the system is ready for the next axle if any.
5. Repeat steps 2 through 5 for each new axle.
6. After all of the axles have been weighed and the scale weight is below t_{HrS} (threshold weight), the t_{dLg} (Total Delay) time expires the total weight will be printed and displayed on the 190 display.

Auto Axle Weighing Ticket Format

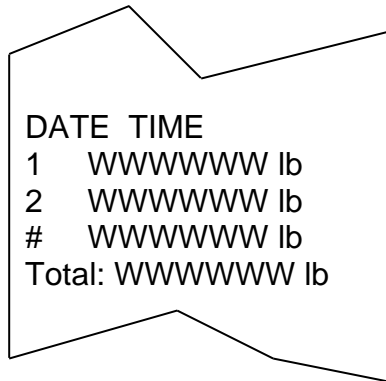

where:

W is the weight, lb is the units.

Once all axles have been weighed and the t_{dLg} (Total Delay) timer runs out (ticket printed), the application is reset and is ready for the next truck.

Wiring

OUT 1 RED light
OUT 2 GREEN light

The PWC outputs will always function if the indicator is set for *Output = 5* and *Auto = YES*. These outputs can be used, or the serial output of the indicator can contain the light state information if continuous data type = 2 (*TYPE = 2*, see below).

TYPE = (Continuous Output Format)

Press the **TARE** \leftarrow key to show the current setting. If the setting displayed is acceptable, press the **TARE** \leftarrow key again to save it.

Otherwise, use the **Fn/▲** key to toggle to a new setting and press the **TARE** \leftarrow key to save it. Allowable settings are:

- 0 = Continuous Output uses SMA format
- 1 = Continuous Output uses Cardinal Scoreboard format
- 2 = Continuous Output uses Cardinal SB500 with traffic control format

NOTE: Refer to the *Cont = Continuous Output on Serial Interface, TYPE =* parameter section for a description of output formats 0 and 1.

Cardinal SB500 with traffic control Continuous Output Format

If Cardinal SB500 with traffic control is selected, the data will be transmitted in the following format:

`%NDDDDDDDDDT<CR>`

where:

- N = Panel number for a daisy chain configuration
- D = Byte of data to display at a respective location on the scoreboard
- T = Control character for the traffic light. Valid characters for T are:
 - = G = Turn on the Green light
 - = R = Turn on the Red light
 - = " "(space) = no lights on
- <CR> = Carriage Return

Scoreboard Interconnections

Serial Option Card P4 Wiring

RS232 Wiring

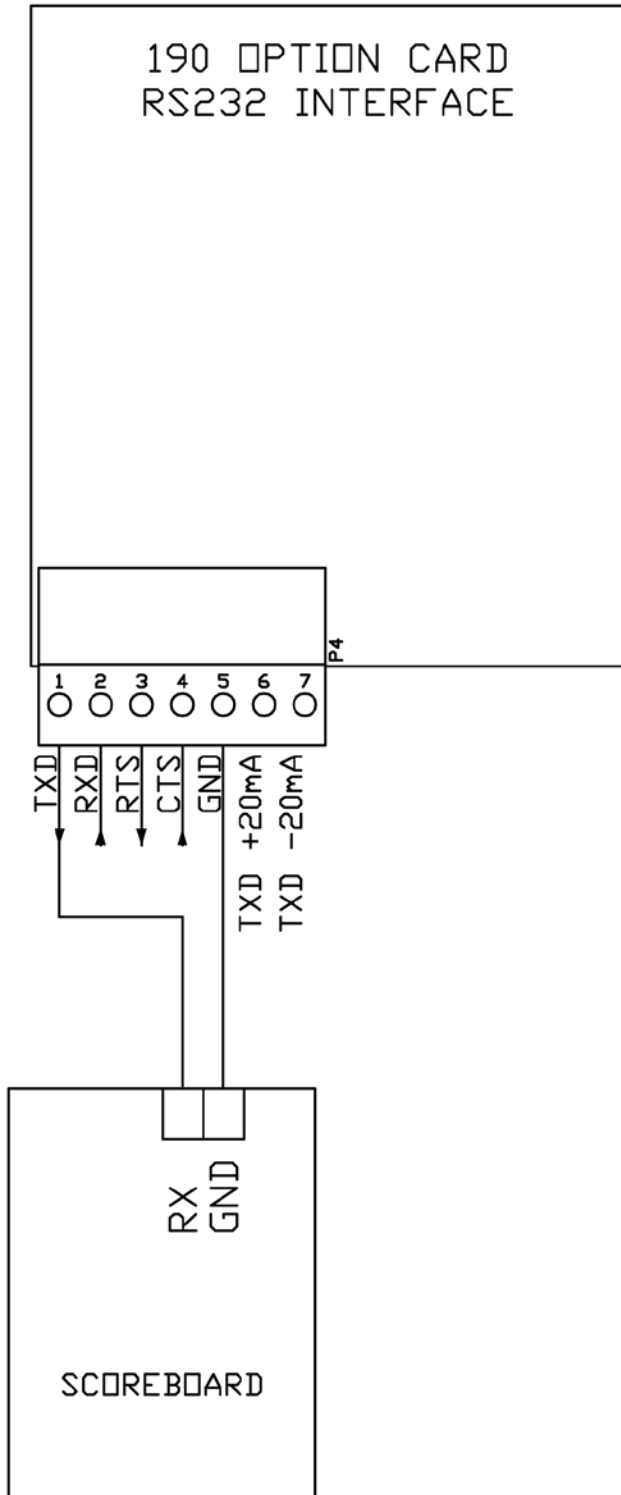

20mA Current Loop (Passive)

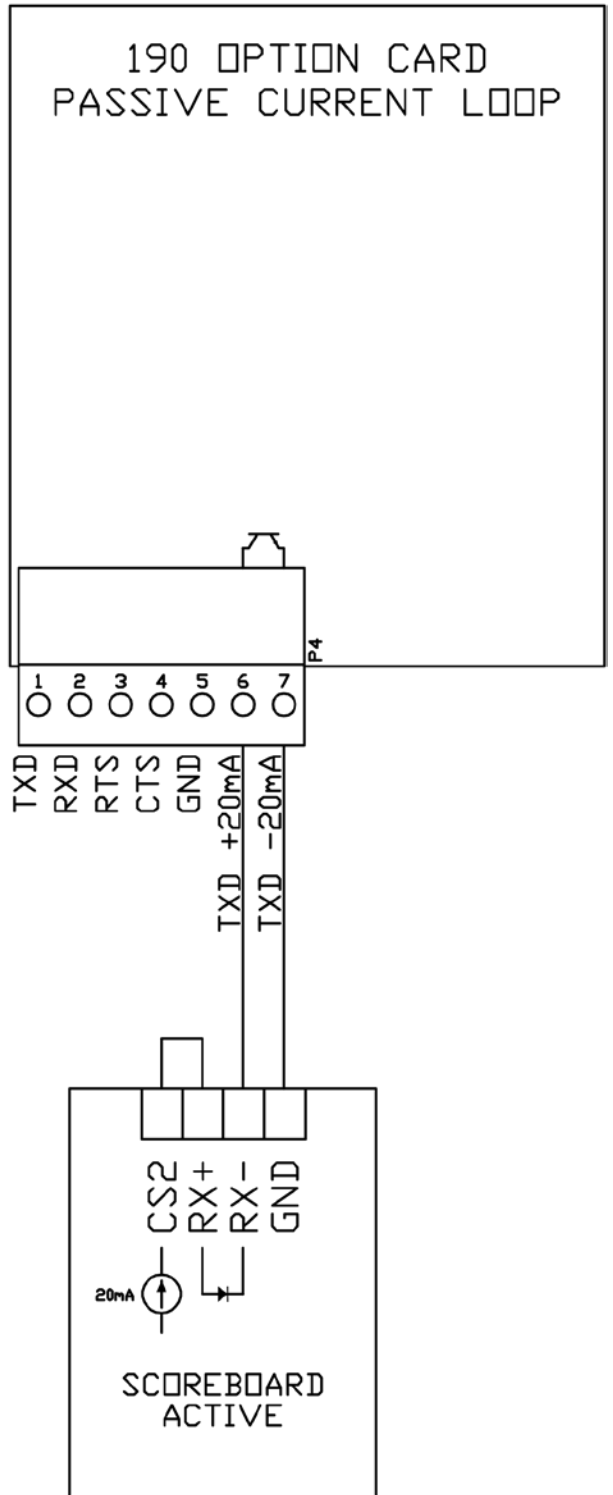

APPENDIX C – 190-RS232 Option

Operation

A connection to the 190-RS232 option card RXD serial input can be used to send commands to the 190. A description of the available commands is described in the ASCII Commands section.

Specifications

Function:	Provides an additional serial port for 190 series indicator
Temperature Range:	14° to 104° F (-10° to +40° C)
Internal Connection:	10-pin DIL
External Connection:	7 terminal pluggable connector

Onboard Status/Diagnostic LED's

The 190-RS232 option card contains one (1) LED to indicate the communication status of the serial connection.

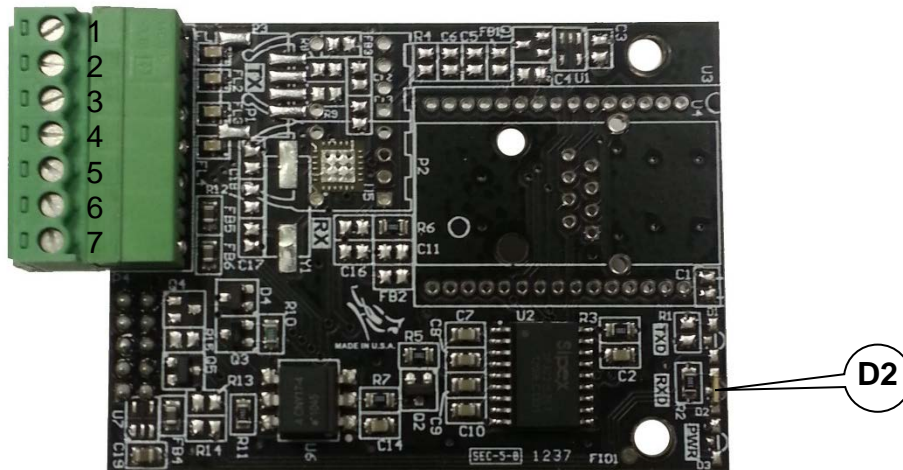

LED	Indication	Description
D2	RXD	Indicates incoming RS-232 data.

Serial Option Card P4 Wiring

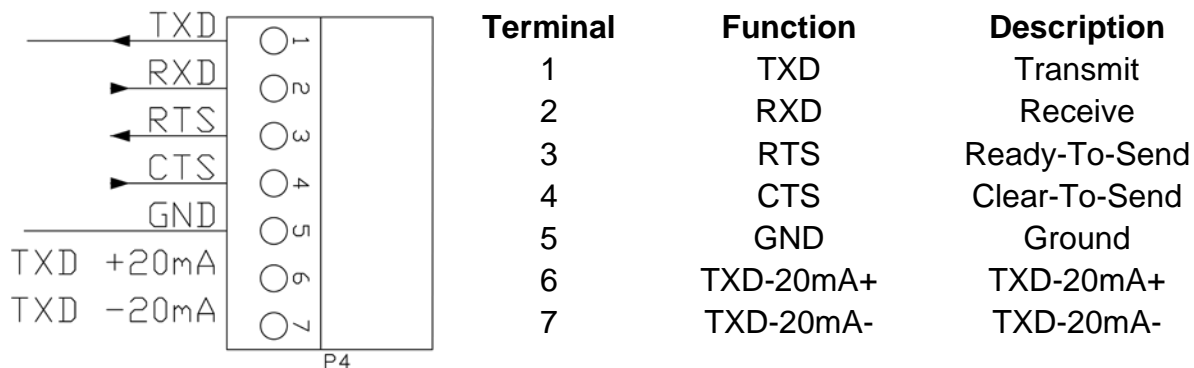

Setup

Enter *SEtUP* and proceed to the Options Setup.

oPt ion

With *oPt ion* displayed, press the **TARE** ↵ key. The display will change to show *oPt =*. Proceed to the *oPt =* parameter.

oPt?

With *oPt?* displayed, press the **TARE** ↵ key. The display will change to *no*. Press the **Fn/▲** key to toggle to *YES* and press the **TARE** ↵ key. The display will change to *oPt =*. Proceed to the *oPt =* parameter.

Otherwise, to skip the Options Setup, press the **TARE** ↵ key to advance to the *FUnC?* prompt.

oPt = (Option)

Press the **TARE** ↵ key to show the current setting. If the setting displayed is acceptable, press the **TARE** ↵ key again to save it.

Otherwise, use the **Fn/▲** key to toggle to a new setting and press the **TARE** ↵ key to save it. Allowable values are:

0 = No Option Card Installed

1 = **Serial Interface**, Ethernet, Wi-Fi, or USB **Option Card Installed**

2 = not applicable

3 = not applicable

4 = Digital to Analog Converter Option Card Installed

baUD = (Optional Serial Interface Baud Rate)

Press the **TARE** ↵ key to show the current setting. If the setting displayed is acceptable, press the **TARE** ↵ key again to save it.

Otherwise, use the **Fn/▲** key to toggle to a new baud rate for the serial ports and press the **TARE** ↵ key to save it. Allowable settings are:

12 = 1200 Baud

24 = 2400 Baud

48 = 4800 Baud

96 = 9600 Baud

19 = 19.2k Baud

38 = 38.4k Baud

76 = 76.8k Baud

Prty: (Optional Serial Interface Parity Setting)

Press the **TARE** ← key to show the current setting. If the setting displayed is acceptable, press the **TARE** ← key again to save it.

Otherwise, use the **Fn/▲** key to toggle to a new setting and press the **TARE** ← key to save it. Allowable settings are:

- 0 = No Parity with 8 data bits
- 1 = Odd Parity with 7 data bits
- 2 = Even Parity with 7 data bits

Cont: (Continuous Output on Optional Serial Interface)

Press the **TARE** ← key to show the current setting. If the setting displayed is acceptable, press the **TARE** ← key again to save it.

Otherwise, use the **Fn/▲** key to toggle to a new setting and press the **TARE** ← key to save it.

- YES = Continuous Output on Optional Serial Interface
- no = No Continuous Output on Optional Serial Interface



IMPORTANT! The setting for the *Prty:* is only applied when the *opt:* parameter is set to 1 and the *Cont:* parameter is set to YES.

TYPE: (Continuous Output Format)

Press the **TARE** ← key to show the current setting. If the setting displayed is acceptable, press the **TARE** ← key again to save it.

Otherwise, use the **Fn/▲** key to toggle to a new setting and press the **TARE** ← key to save it. Allowable settings are:

- 0 = Continuous Output uses SMA format
- 1 = Continuous Output uses Cardinal Scoreboard format
- 2 = Continuous Output uses Cardinal SB500 with traffic control format

NOTE: Refer to the *Cont 1: Continuous Output on Serial Interface, TYPE:* parameter section for a description of output formats 0 and 1.

Cardinal SB500 with traffic control Continuous Output Format

If Cardinal SB500 with traffic control is selected, the data will be transmitted in the following format:

`%NDDDDDDDDDT<CR>`

where:

- N = Panel number for a daisy chain configuration
- D = Byte of data to display at a respective location on the scoreboard
- T = Control character for the traffic light. Valid characters for T are:
 - = G = Turn on the Green light
 - = R = Turn on the Red light
 - = " "(*space*) = no lights on
- <CR> = Carriage Return

APPENDIX D – 190-IP Option

Features

- Standard RJ45 Ethernet port
- Embedded Web server
- 10/100Mb Ethernet – auto-sensing
- No firmware updates necessary to the 190 STORM
- Easy configuration through a Web interface
- High-performance processor (12 MIPS at 48 MHz, 22 MIPS at 88 MHz)
- E-mail client capability
- Password protection
- Status/diagnostic LEDs

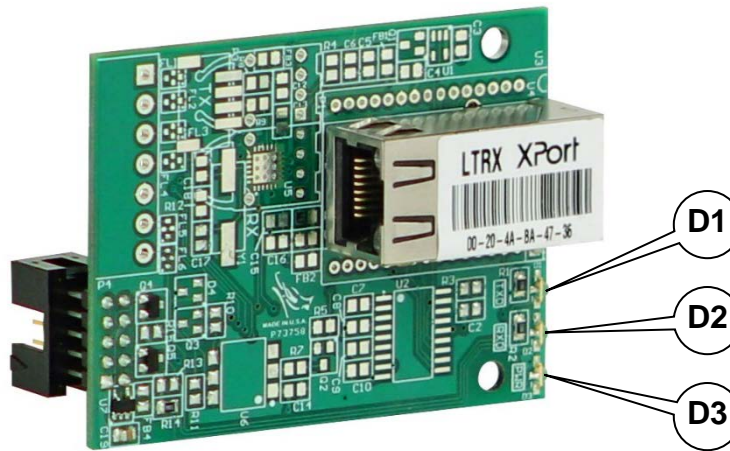

Onboard Status/Diagnostic LED's

The 190-IP option card contains three (3) LEDs to indicate the communication status of the Ethernet TCP/IP connection.

LED	Indication	Description
D1	TXD	Indicates data transferred from the 190
D2	RXD	Indicates data received from the XPORT module
D3	PWR	Indicates power applied to the option card

Setup

Enter *SEtUP* and proceed to the Options Setup.

oPt ion

With *oPt ion* displayed, press the **TARE** ↵ key. The display will change to show *oPt =*. Proceed to the *oPt =* parameter.

oPt ?

With *oPt ?* displayed, press the **TARE** ↵ key. The display will change to *no*. Press the **Fn/▲** key to toggle to *YES* and press the **TARE** ↵ key. The display will change to *oPt =*. Proceed to the *oPt =* parameter.

Otherwise, to skip the Options Setup, press the **TARE** ↵ key to advance to the *FUnC?* prompt.

oPt = (Option)

Press the **TARE** ↵ key to show the current setting. If the setting displayed is acceptable, press the **TARE** ↵ key again to save it.

Otherwise, use the **Fn/▲** key to toggle to a new setting and press the **TARE** ↵ key to save it. Allowable values are:

0 = No Option Card Installed

1 = Serial Interface, **Ethernet**, Wi-Fi, or USB **Option Card Installed**

2 = not applicable

3 = not applicable

4 = Digital to Analog Converter Option Card Installed

baUD = (Option Card Baud Rate)

Press the **TARE** ↵ key to show the current setting. If the setting displayed is 96, press the **TARE** ↵ key again to save it.

Otherwise, use the **Fn/▲** key to toggle the baud rate setting to 96 (9600 Baud) and press the **TARE** ↵ key to save it.

NOTE: The default baud rate is 9600 and must match the baud rate in the XPORT Channel 1 Serial Setting.

Parity = (Option Card Parity Setting)

Press the **TARE** ↵ key to show the current setting. If the setting displayed is 0, press the **TARE** ↵ key again to save it.

Otherwise, use the **Fn/▲** key to toggle the parity setting to 0 (No Parity with 8 data bits) and press the **TARE** ↵ key to save it.

NOTE: The default parity is 0 (No Parity with 8 data bits) and should not be changed.

Cont2: (Continuous Output on Option Card)

Press the **TARE** ↵ key to show the current setting. If the setting displayed is *no* (no), press the **TARE** ↵ key again to save it.

Otherwise, use the **Fn/▲** key to toggle the setting to *no* (No Continuous Output on Option Card) and press the **TARE** ↵ key to save it.

NOTE: The default continuous output is *no* (No Continuous Output on Option Card) and should not be changed.

Ethernet Cable Installation

Connections to the 190 are by CAT 5 or equivalent cable. Consult your network administrator for the proper procedure to terminate the cable.

After the cable has been terminated, plug the cable into the Ethernet port on the 190-IP.

IP Address Setup

Before operation may begin the Ethernet Device Server must have an IP Address. The 190-IP option card IP address is set using the DeviceInstaller by Lantronix, available when logged into the dealer-protected software section of CardinalScale.com. Download the application and its user's guide from CardinalScale.com by navigating to 190 Storm > Resource Type > Software > Lantronix DeviceInstaller for Cardinal IP Devices.

190-IP Operation

A client TCP connection to the 190-IP IP address at its listening port, 10001, can be used to send commands to the 190. A description of the available commands is described in the ASCII Commands section.

XPORT Connector Status LED's

LEDs are provided on the edge of the XPORT connector for diagnostics. Their status and meaning are listed below.

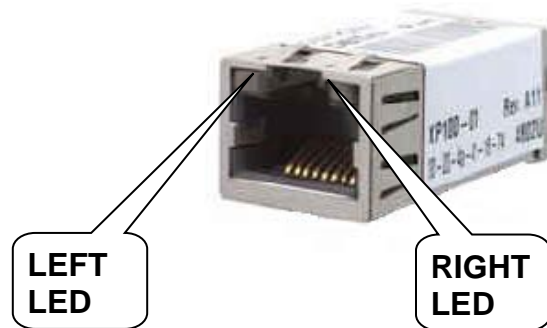

LEFT LED	RIGHT LED	MEANING
OFF	OFF	No Link
OFF	Solid Amber	100BASE-T Half Duplex Link
OFF	Blinking Amber	100BASE-T Half Duplex; Activity
OFF	Solid Green	100BASE-T Full Duplex Link
OFF	Blinking Green	100BASE-T Full Duplex; Activity
Solid Amber	OFF	10BASE-T Half Duplex Link
Blinking Amber	OFF	10BASE-T Half Duplex; Activity
Solid Green	OFF	10BASE-T Full Duplex Link
Blinking Green	OFF	10BASE-T Full Duplex; Activity

APPENDIX E – 190-WiFi Option

The 190-WiFi Option is used to connect the 190 digital weight indicator to IEEE 802.11b/g wireless local area networks (wireless LAN). When the indicator is powered on, the Wi-Fi option card will connect to a wireless LAN matching the configuration stored in the option card.

Specifications

Wireless Network Type:	Server (SoftAP)
Service Set Identifier (SSID):	190WIFI-##*
Wireless Channel:	6
Security:	None
LAN IP Address:	192.168.0.100
LAN Subnet Mask:	255.255.255.0



* **NOTE:** ## is the last 2 digits of the MAC address of the module.

Onboard Status/Diagnostic LED's

The 190-WiFi option card contains four (4) LEDs to indicate the communication status of the wireless connection.

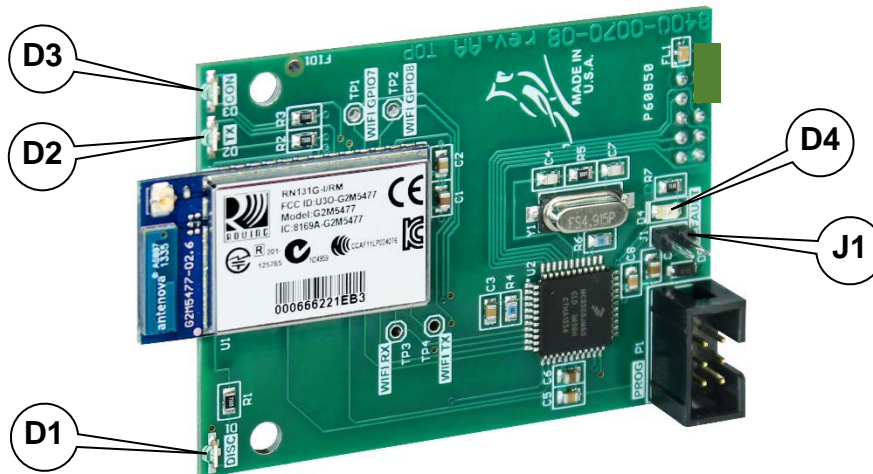

LED	Indication	Description
D1	DISC	This LED indicates that Discovery Mode is active on the 190-WIFI. Discovery Mode affects whether the 190-WIFI can see (find) computers and devices on the network and whether other computers on the network can see the 190-WIFI.
D2	TXD	This LED will illuminate when the 190-WIFI has been successfully connected to a network and will flicker when there is data activity over the wireless network.
D3	CON	This LED displays the communication status. It will be ON or flashing rapidly when communications between the 190-WIFI and the wireless network are established.
D4	DEFAULT	This LED will illuminate to indicate the 190-WIFI is in the process of resetting the configuration. When the reset to defaults is complete you should see the LED flash 5 times and then go out when it is complete.

Setup

Enter *SEtUP* and proceed to the Options Setup.

oPt ion

With *oPt ion* displayed, press the **TARE** \leftarrow key. The display will change to show *oPt =*. Proceed to the *oPt =* parameter.

oPt ?

With *oPt ?* displayed, press the **TARE** \leftarrow key. The display will change to *no*. Press the **Fn/▲** key to toggle to *YES* and press the **TARE** \leftarrow key. The display will change to *oPt =*. Proceed to the *oPt =* parameter.

Otherwise, to skip the Options Setup, press the **TARE** \leftarrow key to advance to the *FUnC?* prompt.

oPt = (Option)

Press the **TARE** \leftarrow key to show the current setting. If the setting displayed is acceptable, press the **TARE** \leftarrow key again to save it.

Otherwise, use the **Fn/▲** key to toggle to a new setting and press the **TARE** \leftarrow key to save it. Allowable values are:

0 = No Option Card Installed

1 = Serial Interface, Ethernet, **Wi-Fi**, or USB **Option Card Installed**

2 = not applicable

3 = not applicable

4 = Digital to Analog Converter Option Card Installed

baud = (Option Card Baud Rate)

Press the **TARE** \leftarrow key to show the current setting. If the setting displayed is 96, press the **TARE** \leftarrow key again to save it.

Otherwise, use the **Fn/▲** key to toggle the baud rate setting to 96 (9600 Baud) and press the **TARE** \leftarrow key to save it.

NOTE: The default baud rate is 9600 and should not be changed.

Parity = (Option Card Parity Setting)

Press the **TARE** \leftarrow key to show the current setting. If the setting displayed is 0, press the **TARE** \leftarrow key again to save it.

Otherwise, use the **Fn/▲** key to toggle the parity setting to 0 (No Parity with 8 data bits) and press the **TARE** \leftarrow key to save it.

NOTE: The default parity is 0 (No Parity with 8 data bits) and should not be changed.

Cont: (Continuous Output on Option Card)

Press the **TARE** \leftarrow key to show the current setting. If the setting displayed is acceptable, press the **TARE** \leftarrow key again to save it.

Otherwise, use the **Fn/▲** key to toggle to a new setting and press the **TARE** \leftarrow key to save it.

YES = Continuous Output on Optional Serial Interface

no = No Continuous Output on Optional Serial Interface



IMPORTANT! The setting for the *TYPE:* is only applied when the *opt:* parameter is set to 1 and the *Cont:* parameter is set to YES.

TYPE: (Continuous Output Format)

Press the **TARE** \leftarrow key to show the current setting. If the setting displayed is acceptable, press the **TARE** \leftarrow key again to save it.

Otherwise, use the **Fn/▲** key to toggle to a new setting and press the **TARE** \leftarrow key to save it. Allowable settings are:

0 = Continuous Output uses SMA format

1 = Continuous Output uses Cardinal Scoreboard format

2 = Continuous Output uses Cardinal SB500 with traffic control format

NOTE: Refer to the *Cont 1:* Continuous Output on Serial Interface, *TYPE:* parameter section for a description of output formats 0 and 1.

Network Configuration

Connecting to 190-WIFI Access Point (Ad Hoc)

From the initial factory settings, the 190-WIFI will appear as a wireless access point with the name “190WIFI”. To connect to 190-WIFI for initial setup, you will need to connect to it as a wireless access point using a wireless device such as a laptop, PC, tablet, or smartphone. Once connected you can make use of the full functionality described in the Operation section below.

Connecting to an Existing Network

To set up 190-WIFI to connect to an existing network:

1. Power on the indicator with the 190-WIFI installed.
2. Connect to the 190-WIFI access point.
3. With a PC or laptop, use a communications program or a terminal client to connect to the wireless module IP address and port 10001. The default IP address is 192.168.0.100.
4. Once connected, send three ‘\$’ characters and press enter. The module should reply with “CMD” and is now in command mode.
5. To launch the web configuration utility, type “**run web_app**” into the terminal console window and press Enter. This will cause the 190-WIFI to reboot in the web configuration mode where you can set it to connect to an existing network.
6. Since the module rebooted, you will need to reconnect to the 190WIFI access point. Once you have reconnected to the WIFI module, launch a web browser and navigate to

<http://config>

If your attempt to browse to this page is unsuccessful, you may need to disable any other Ethernet adapters besides the wireless adapter being used to connect to the 190-WIFI module. Make sure to start the web configuration app by briefly applying the DEFAULTS jumper before connecting to the 190-WIFI access point.

You should then be presented with a new page that contains a form that can be used to set up the network configuration to either connect to an existing network or act as a wireless access point. On the next page is an image of how this screen will appear as well as functional descriptions of each of the settings.

Reset to Defaults – Jumper J1

If you change the network settings in such a way that you can no longer access 190-WIFI, a jumper has been provided (J1 DEFAULT) to reset the network configuration to the initial factory defaults.

To reset the 190-WIFI module to defaults, set the jumper in the shorted position and apply power to the 190. You should see the DEFAULT LED (D3) light up while 190-WIFI is in the process of resetting the configuration. When the reset to defaults is complete you should see the LED flash 5 times and then go out when it is complete.

It is necessary to completely remove the power and re-apply power to ensure that the default settings have taken effect.

This means that it is very important that the DEFAULTS jumper NOT be left in place on the board for normal operation and should only be used if trying to recover a module with incorrect settings.

At this point, 190-WIFI should continue with normal operation using the default configuration.

NOTE: The DEFAULTS jumper will launch the configuration web page if set briefly after power up.

Web Configuration Parameter Descriptions – Access Point

The configuration web page in the 190-WIFI module allows the module to be configured as either an access point or to connect to an existing network. To accomplish this, a new parameter has been added on the web page “Network Mode”.

 **MICROCHIP**

Network Configuration **Information**

Network Mode
Server (SoftAP) ▼

Access Point SSID
190WIFI

Security Mode
Open ▼

IP Address
192.168.0.100

Network Mask
255.255.255.0

Gateway IP Address
192.168.0.100

Enable DHCP Server (recommended)

Save & Reboot **Cancel**

Network Mode

This parameter allows the 190-WIFI module to be configured as either an access point, or to connect to an existing network.

To set up the 190-WIFI module as an access point, set the mode to “Server (SoftAP).”

Access Point SSID

Enter the SSID of the access point you wish to connect to here. If no access point exists with the SSID that is entered, then the 190-WIFI module will attempt to start an access point with the entered SSID.

Security Mode

When the “Network Mode” is set to “Server (SoftAP)” mode, then this sets the security type that will be used to connect to the module acting as an access point. The password used by the connecting device must match the password set on the configuration web page to connect to the module.

IP Address

Enter the static IP address of the 190-WIFI module here.

Network Mask

Enter the desired Netmask here.

Gateway IP Address

Enter the default gateway IP address here.

Enable DHCP Server (recommended)

When “Server (SoftAP)” mode is active, the “Enable DHCP Server” checkbox will enable the DHCP server to assign addresses automatically to connecting devices.

NOTE: If this check box is unchecked in this mode, it will be important to set static IP addresses in the devices connecting to the WIFI module that is compatible with the settings that are set in the module itself.

Once all settings have been entered, click “Save & Reboot” at the bottom of the webpage to save the parameters.



NOTE: It is very important not to press “Enter” before all of the configuration settings have been properly entered. Pressing “Enter” before entering in all of the appropriate settings will submit the information and may put the device into a state where it cannot be connected to. If this happens, it may be necessary to isolate the 190-WIFI module from wireless signals and use the DEFAULT jumper to restore the network to a known configuration.

Web Configuration Parameter Descriptions – Client (Infrastructure)

The configuration web page in the 190-WIFI module allows the module to be configured as either an access point or to connect to an existing network. To accomplish this, a new parameter has been added on the web page “Network Mode”.

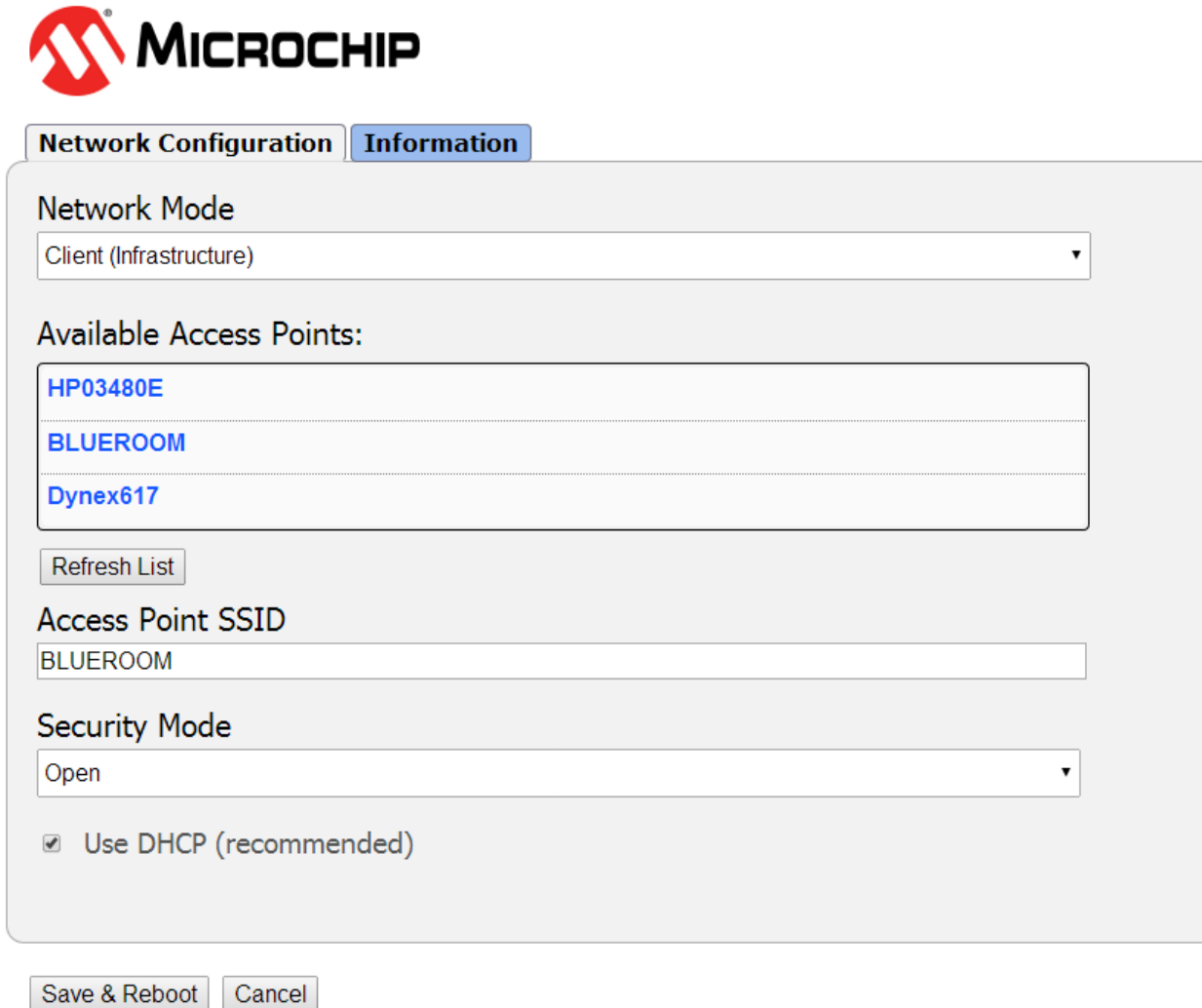

MICROCHIP

Network Configuration Information

Network Mode
Client (Infrastructure)

Available Access Points:

- HP03480E
- BLUEROOM
- Dynex617

Refresh List

Access Point SSID
BLUEROOM

Security Mode
Open

Use DHCP (recommended)

Save & Reboot Cancel

Network Mode

This parameter allows the 190-WIFI module to be configured as either an access point or to connect to an existing network. To set the module to connect to an existing network, change the “Network Mode” to “Client (Infrastructure)”.

Available Access Points

Click the “Refresh List” button to scan for available access points that the 190-WIFI module can connect to. You can select an AP by clicking on its name in the list.

Access Point SSID

Enter the SSID of the access point you wish to connect to here. If no access point exists with the SSID that is entered, then the 190-WIFI module will attempt to start an access point with the entered SSID.

Security Mode

When the “Network Mode” is set to “Client (Infrastructure)” mode, this sets the security type that the module will use to attempt to connect to the existing network. This will be beneficial when attempting to connect to certain secured networks that the older firmware was having issues in properly detecting the security type.

Use DHCP (recommended)

When the “Client (Infrastructure)” mode is active, the “Use DHCP” will cause the module to try and obtain an IP address automatically when it connects to an existing network.

NOTE: Having this box checked may make the module difficult to locate on an existing network unless the existing network has been configured to always assign the same IP address to the WIFI module.

When set to connect to an existing network, it is recommended to use static IP addressing to make connecting to the module easier.

Once all settings have been entered, click “Save & Reboot” at the bottom of the webpage to save the parameters.



NOTE: It is very important not to press “Enter” before all of the configuration settings have been properly entered. Pressing “Enter” before entering in all of the appropriate settings will submit the information and may put the device into a state where it cannot be connected to. If this happens, it may be necessary to isolate the 190-WIFI module from wireless signals and use the DEFAULT jumper to restore the network to a known configuration.

Wi-Fi Operation

A connection to the 190-WIFI option card can be used to send commands to the 190. A description of the available commands is described in the ASCII Commands section.

APPENDIX F – 190-DAC OPTION

The 190-DAC is an option card for the 190 that outputs an analog 0-10V or 0-24mA. The user can control the output voltage or current using the DAC interface in the 190. The DAC has sense jumpers that allow the user to connect the 190-DAC card voltage or current lines long distances.

If the Voltage or Current lines need to go long distances the user will need to connect the polarized sense lines as close to the other end connections as possible and remove sense jumpers J1 (+SEN) and J2 (-SEN). Refer to the DAC Wiring section for the location of J1 and J2. If the sense lines are not needed the jumpers need to be installed.



NOTE: The 190-DAC Option cannot be added in the field. It *requires* returning the 190 to the factory to perform the upgrade.

Specifications

Temperature Range:	14° to 104° F (-10° to +40° C)
Maximum Load Resistance: 0 – 20 mA and 4 – 20 mA 0 – 24 mA	500 ohms 450 ohms
Minimum load resistance:	2K ohms
Internal Connection:	10-pin DIL
+9V Internal Connection: Connect to P2 of 190 Main Board Pin +9V and GND (Refer to the DAC Wiring section)	9VDC ± 5%
External Connection:	5 terminal pluggable connector
Output Isolation:	1kV

Onboard Status/Diagnostic LED's

The 190-DAC option card contains four (4) LEDs to indicate run time status and errors to the user.

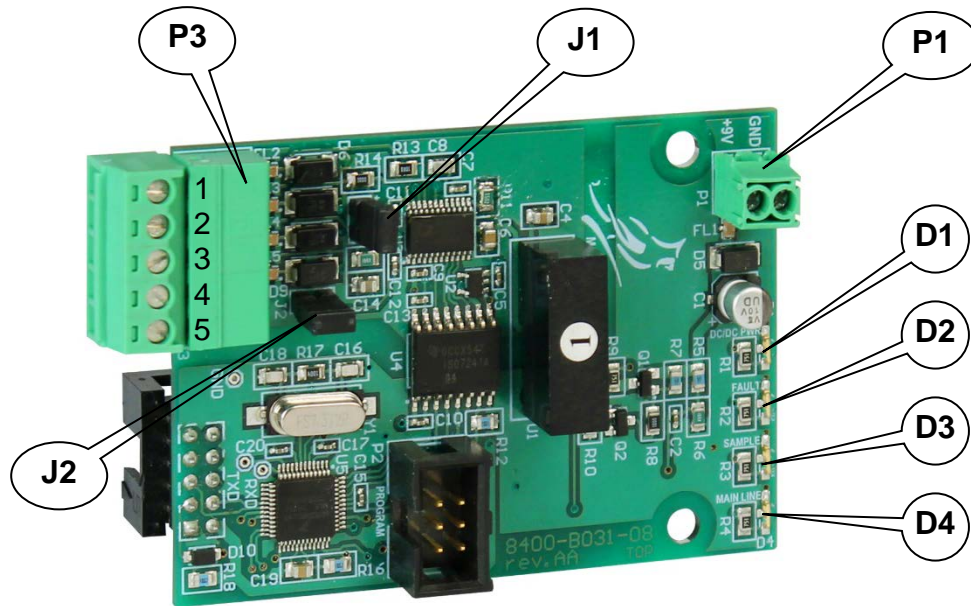

LED	Indication	Description
D1	DC/DC Power	Voltage is in tolerance $9V \pm 5\%$ and isolated DAC is powered. NOTE: The DC/DC Power (D1) LED will be on continuously when the DAC is powered.
D2	Fault	<u>IOUT Fault</u> – Current loop is an open circuit or insufficient power supply voltage to drive the load. <u>Over Temp</u> – DAC core temperature has exceeded the limit.
D3	Sample	Blinks each time Sample is received
D4	Mainline	Heartbeat monitor that blinks each time through mainline routine

Setup

Enter *SEtUP* and proceed to the Options Setup.

oPt ion

With *oPt ion* displayed, press the **TARE** \leftarrow key. The display will change to show *oPt =*. Proceed to the *oPt =* parameter.

oPt?

With *oPt?* displayed, press the **TARE** \leftarrow key. The display will change to *no*. Press the **Fn/▲** key to toggle to *YES* and press the **TARE** \leftarrow key. The display will change to *oPt =*. Proceed to the *oPt =* parameter.

Otherwise, to skip the Options Setup, press the **TARE** \leftarrow key to advance to the *FUnC?* prompt.

oPt = (Option)

Press the **TARE** \leftarrow key to show the current setting. If the setting displayed is acceptable, press the **TARE** \leftarrow key again to save it.

Otherwise, use the **Fn/▲** key to toggle to a new setting and press the **TARE** \leftarrow key to save it. Allowable values are:

- 0 = No Option Card Installed
- 1 = Serial Interface, Ethernet, Wi-Fi, or USB Option Card Installed
- 2 = not applicable
- 3 = not applicable
- 4 = Digital to Analog Converter Option Card Installed**

rRnGE =

Press the **TARE** \leftarrow key to show the current setting. If the setting displayed is acceptable, press the **TARE** \leftarrow key again to save it.

Otherwise, use the **Fn/▲** key to toggle to a new setting and press the **TARE** \leftarrow key to save it. Allowable values are:

- 0 = 4-20 ma
- 1 = 0-20 ma
- 2 = 0-24 ma
- 3 = 0-10 volts
- 4 = 0-5 volts
- 5 = -10 to +10 volts
- 6 = -5 to +5 volts

Lo =

This is the value, in weight, which outputs zero volts (or 0 or 4 ma) from the DAC. All weight below this target will output zero volts (or 0 or 4 ma).

Press the **TARE** \leftarrow key to show stored value. If the setting is acceptable, press the **TARE** \leftarrow key again to save it.

Otherwise, using the numeric keys enter the desired weight value, and press the **TARE** \leftarrow key to save it. Allowable values are -99999 to 999999.

NOTE: The **NET/GROSS** key is used to change the weight sign. For example, to input -1000 as the weight value, press 1000 **NET**.

H₁ =

This is the value, in weight, which outputs the maximum selected voltage and current (see **oUt =**). All weights above this value will output maximum volts from the DAC.

Press the **TARE** \leftarrow key to show the stored value. If the setting is acceptable, press the **TARE** \leftarrow key again to save it.

Otherwise, using the numeric keys enter the desired weight value, and press the **TARE** \leftarrow key to save it. Allowable values are 1 to 999999.

NOTE: This weight must be a positive value, up to the capacity of the scale, and above the **H₁ =** value.

oUt =

This is the maximum output value in volts (00.01 to 10.00). All weight values equal to or greater than **H₁ =** will output this value.

NOTE: If the scale goes **oC RP** (over capacity), this value is used.

Press the **TARE** \leftarrow key to show the stored value. If the setting is acceptable, press the **TARE** \leftarrow key again to save it.

Otherwise, using the numeric keys enter the desired output value, and press the **TARE** \leftarrow key to save it. Allowable values are 00.01 to 10.00.

NOTE: If one of the current output ranges is selected, set **oUt =** to:

4-20 ma:	$10 \times (\text{max_current} - 4) / 16$
0-20 ma:	$10 \times (\text{max_current}) / 20$
0-24 ma:	$10 \times (\text{max_current}) / 24$
+1-5	Set OUT = 5.00

dARCtSt

Press the **TARE** \leftarrow key and the **Fn/▲** key to switch to the *YES* prompt.

Press the **TARE** \leftarrow key to enter the DAC output test function, pressing the **TARE** \leftarrow key with the *no* prompt will skip the output test.

The *dARC Lo* prompt is displayed and the output of the DAC is the Low value for the range selected.

Press the **Fn/▲** key to switch to the High value of the range on the DAC output, *dARC Hi* will be displayed.

Continue pressing the **Fn/▲** key to toggle between the Low and High output.

When done testing the DAC output press the **TARE** \leftarrow key.

gDAC =

This sets the DAC output to follow the Gross weight only or the displayed weight (gross or net).

Press the **TARE** \leftarrow key to show the current value. If the setting displayed is acceptable, press the **TARE** \leftarrow key again to save it and advance to the *FUNC?* prompt.

Otherwise, press the **Fn/▲** key to toggle between *YES* and *no* and press the **TARE** \leftarrow key and advance to the *FUNC?* prompt.

gDAC = YES

DAC output is Gross Weight Only

gDAC = no

DAC output is the displayed Weight (gross or net)

DAC Wiring

DAC Option Card P1 Power Connection

To power the DAC option card, connect P1 on the DAC (Pin +9V and GND) to connector P2 of 190 Main Board (Pin +9V and GND).

DAC Option Card P3 Analog Out Connections

Terminal	Function
1	IOUT
2	VOUT
3	+SENSE
4	-SENSE
5	ISO GND

APPENDIX G – 190-USB Option

Features

The 190-USB Option is a standard full-speed (12Mbps) USB 2.0 device (or upstream) port. It can be connected to a USB 2.0 host, with the Cardinal Scale 8200-B512-0A USB CABLE, to be used as a serial I/O port.

NOTE: The 190-USB driver and driver installation instructions are available when logged into the dealer-protected software section of CardinalScale.com. Download the driver and its installation instructions from CardinalScale.com by navigating to 190 Storm > Resource Type > Software > 190-USB Driver.

Onboard Status/Diagnostic LED's

The 190-USB option card contains three (3) LEDs to indicate the communication status of the USB connection.

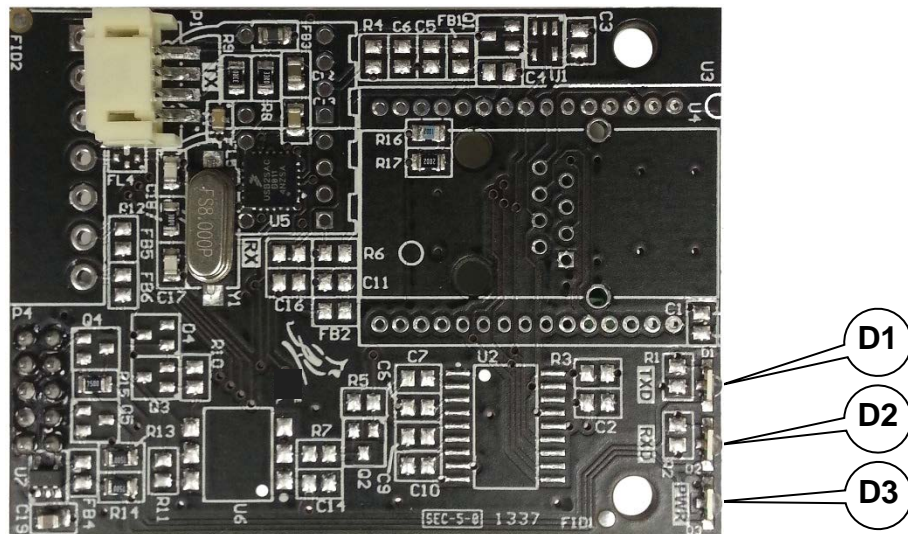

LED	Label	Description
D1	TXD	Indicates the 190-USB has been successfully connected to a serial device and will flicker when there is USB data activity.
D2	RXD	Indicates activity between the 190-USB and the indicator. If D2 is not flashing, communications have failed between the 190-USB and the indicator.
D3	PWR	Indicates power applied to the option card

Setup

Enter *SEtUP* and proceed to the Options Setup.

oPt ion

With *oPt ion* displayed, press the **TARE** ↵ key. The display will change to show *oPt =*. Proceed to the *oPt =* parameter.

oPt ?

With *oPt ?* displayed, press the **TARE** ↵ key. The display will change to *no*. Press the **Fn/▲** key to toggle to *YES* and press the **TARE** ↵ key. The display will change to *oPt =*. Proceed to the *oPt =* parameter.

Otherwise, to skip the Options Setup, press the **TARE** ↵ key to advance to the *FUnC?* prompt.

oPt = (Option)

Press the **TARE** ↵ key to show the current setting. If the setting displayed is acceptable, press the **TARE** ↵ key again to save it.

Otherwise, use the **Fn/▲** key to toggle to a new setting and press the **TARE** ↵ key to save it. Allowable values are:

0 = No Option Card Installed

1 = Serial Interface, Ethernet, Wi-Fi, or **USB Option Card Installed**

2 = not applicable

3 = not applicable

4 = Digital to Analog Converter Option Card Installed

baUD = (Option Card Baud Rate)

Press the **TARE** ↵ key to show the current setting. If the setting displayed is 96, press the **TARE** ↵ key again to save it.

Otherwise, use the **Fn/▲** key to toggle the baud rate setting to 96 (9600 Baud) and press the **TARE** ↵ key to save it.

NOTE: The default baud rate is 9600 and *should not* be changed.

Prty = (Option Card Parity Setting)

Press the **TARE** ↵ key to show the current setting. If the setting displayed is 0, press the **TARE** ↵ key again to save it.

Otherwise, use the **Fn/▲** key to toggle the parity setting to 0 (No Parity with 8 data bits) and press the **TARE** ↵ key to save it.

NOTE: The default parity is 0 (No Parity with 8 data bits) and *should not* be changed.

Cont: (Continuous Output on Option Card)

Press the **TARE** \leftarrow key to show the current setting. If the setting displayed is acceptable, press the **TARE** \leftarrow key again to save it.

Otherwise, use the **Fn/▲** key to toggle to a new setting and press the **TARE** \leftarrow key to save it.

YES = Continuous Output on Optional Serial Interface

no = No Continuous Output on Optional Serial Interface



IMPORTANT! The setting for the *TYPE:* is only applied when the *opt:* parameter is set to 1 and the *Cont:* parameter is set to YES.

TYPE: (Continuous Output Format)

Press the **TARE** \leftarrow key to show the current setting. If the setting displayed is acceptable, press the **TARE** \leftarrow key again to save it.

Otherwise, use the **Fn/▲** key to toggle to a new setting and press the **TARE** \leftarrow key to save it. Allowable settings are:

0 = Continuous Output uses SMA format

1 = Continuous Output uses Cardinal Scoreboard format

2 = Continuous Output uses Cardinal SB500 with traffic control format



NOTE: Continuous Output *TYPE:* settings are for the selection of the format only. A scoreboard cannot be connected directly to the 190-USB.

NOTE: Refer to the *Cont 1:* Continuous Output on Serial Interface, *TYPE:* parameter section for a description of output formats 0 and 1.

190-USB Operation

A connection to the 190-USB option card can be used to send commands to the 190. A description of the available commands is described in the ASCII Commands section.



NOTE: When the 190 indicator is turned OFF, power is removed from the USB transceiver. The serial communication software connecting the computer to the 190-USB must be disconnected before the 190 indicator is turned OFF. If the communication software does not release the connection to the USB Comm port before power to the 190 indicator is turned off, the USB Comm connection will not restore the connection when the 190 indicator is powered ON again. To restore the connection, the USB cable must be unplugged and reconnected.

STATEMENT OF LIMITED WARRANTY

WARRANTY TERMS

Cardinal Scale Manufacturing Company warrants the equipment we manufacture against defects in material and workmanship. The length and terms and conditions of these warranties vary with the type of product and are summarized below:

PRODUCT TYPE	TERM	MATERIAL AND WORKMANSHIP	LIGHTNING DAMAGE See note 9	WATER DAMAGE See note 7	CORROSION See note 4	ON-SITE LABOR	LIMITATIONS AND REQUIREMENTS
WEIGHT INDICATORS	90 DAY REPLACEMENT ----- 1 YEAR PARTS	YES	YES	YES	YES	NO	1, 2, 3, 5, 6 A, B, C, D
LOAD CELLS (Excluding Hydraulic)	1 YEAR	YES	YES	YES	YES	NO	1, 2, 3, 5, 6 A, B, C, D
HYDRAULIC LOAD CELLS (When purchased with Guardian Vehicle Scale)	LIFETIME	YES	YES	YES	YES	90 DAYS	1, 5, 6, 8 A, B, C, D
HYDRAULIC LOAD CELLS (When purchased separately)	10 YEARS	YES	YES	YES	YES	NO	1, 5, 6, 8, 9 A, B, C, D
VEHICLE SCALE (Deck and Below Excl. PSC Series)	5 YEARS	YES	YES	YES	YES	90 DAYS	1, 2, 3, 5, 6 A, B, C, D, E
LSC SCALE (Deck and Below)	3 YEARS	YES	YES	YES	YES	90 DAYS	1, 2, 3, 5, 6, 11 A, B, C, D
GUARDIAN FLOOR SCALES	10 YEARS	YES	YES	YES	YES	NO	1, 2, 3, 5, 6, 9, 10 A, B, C, D
ALL OTHER CARDINAL PRODUCTS	1 YEAR	YES	YES	YES	YES	NO	1, 2, 5, 6 A, B, C, D, E
REPLACEMENT PARTS	90 DAYS	YES	YES	YES	YES	NO	1, 2, 4, 5, 6 A, B, C, D
SWIM AND 760 SERIES VEHICLE SCALES	1 YEAR	YES	YES	YES	YES	90 DAYS	1, 2, 5, 6 A, B, C, D
SOFTWARE	90 DAYS	YES	N/A	N/A	N/A	NO	1, 6 B, C, D
CONVEYOR BELT SCALES (including Belt-Way)	1 YEAR	YES	YES	YES	YES	NO	1, 2, 3, 5, 6 A, B, C, D, E, F



CARDINAL

Ph. (800) 441-4237
E-mail: cardinal@cardet.com
102 E. Daugherty
Webb City, MO 64870

04/24
Printed in USA
315-WARRANTY-CAR-M

APPLICABLE LIMITATIONS AND REQUIREMENTS

1. This warranty applies only to the original purchaser. The warranty does not apply to equipment that has been tampered with, defaced, damaged, or had repairs or modifications not authorized by Cardinal or has had the serial number altered, defaced or removed.
2. This warranty is not applicable to equipment that has not been grounded in accordance with Cardinal's recommendations.
3. This equipment must be installed and continuously maintained by an authorized Cardinal / Belt-Way dealer.
4. Applies only to components constructed from stainless steel.
5. This warranty does not apply to equipment damaged in transit. Claims for such damage must be made with the responsible freight carrier in accordance with freight carrier regulations.
6. Warranty term begins with date of shipment from Cardinal.
7. Only if device is rated NEMA 4 or better or IP equivalent.
8. Lifetime warranty applies to damages resulting from water, lightning, and voltage transients and applies only to the hydraulic load cell structure itself (does not include pressure transducers, rubber seals, o-rings, and associated wiring).
9. 10-Year prorated warranty on hydraulic load cells.
10. 1-Year warranty for scale structure.
11. PSC models' warranty coverage applies only to agricultural installations on farms up to 3,000 acres (LSC models not limited in this manner).
12. Load cell kits MUST be installed in accordance with Cardinal Scale instructions. Failure to follow these instructions will void the warranty.

EXCLUSIONS

- A.) This warranty does not include replacement of consumable or expendable parts. The warranty does not apply to any item that has been damaged due to unusual wear, abuse, improper line voltage, overloading, theft, fire, water, prolonged storage or exposure while in purchaser's possession or acts of God unless otherwise stated herein.
- B.) This warranty does not apply to peripheral equipment not manufactured by Cardinal. This equipment will normally be covered by the equipment manufacturer's warranty.
- C.) This warranty sets forth the extent of our liability for breach of any warranty or deficiency in connection with the sale or use of our product. Cardinal will not be liable for consequential damages of any nature, including but not limited to loss of profit, delays or expenses, whether based on tort or contract. Cardinal reserves the right to incorporate improvements in material and design without notice and is not obligated to incorporate said improvements in equipment previously manufactured.
- D.) This warranty is in lieu of all other warranties expressed or implied including any warranty that extends beyond the description of the product including any warranty of merchantability or fitness for a particular purpose. This warranty covers only those Cardinal products installed in the forty-eight contiguous United States and Canada.
- E.) This warranty does not cover paint coatings due to the variety of environmental conditions.
- F.) Do not cut load cell cables on load cells returned for credit or warranty replacement. Cutting the cable will void the warranty.
- G.) Software is warranted only for performance of the functions listed in the software manual and/or the Cardinal proposal.
- H.) The software warranty does not cover hardware. Warranties on hardware are provided from the hardware vendor only.
- I.) The software warranty does not cover interfacing issues to non-Cardinal supplied hardware.
- J.) The software warranty does not include automatic software upgrades unless purchased separately.



Ph. (800) 441-4237
E-mail: cardinal@cardet.com
102 E. Daugherty
Webb City, MO 64870

04/24
Printed in USA
315-WARRANTY-CAR-M

Cardinal Scale Mfg. Co.

102 E. Daugherty, Webb City, MO 64870 USA

Ph: 417-673-4631 or 1-800-641-2008

Fax: 417-673-2153

www.cardinalscale.com

Technical Support: 1-866-254-8261

E-mail: tech@cardet.com

Printed in USA

8400-M022-O1 Rev K 04/21