



**4500 Series
Platform Mechanical
Bench Scale
Owner's Manual**

INTRODUCTION

The Detecto 4500 Series Platform Mechanical Scale is ideal for use in smaller commercial and industrial applications that require high performance with minimum cost. The scale is durable, having a sturdy enameled steel scale base, and is available in single weigh beam capacities of 130 lb x 1 oz or 450 lb x 4 oz, and a front and back reading dual weigh beam capacity of 440 lb x 4 oz/200 kg x 100 g.

This manual is provided to guide you through the assembly and operation of your scale. Please read it thoroughly before attempting to assemble or operate your scale and keep it available for future reference.

This manual is for use with the following Platform Mechanical Scale models:

4570, 4520, 4520B, and 4527PK

COPYRIGHT

All rights reserved. Reproduction or use, without expressed written permission, of editorial or pictorial content, in any manner, is prohibited. No patent liability is assumed with respect to the use of the information contained herein.

DISCLAIMER

While every precaution has been taken in the preparation of this manual, the Seller assumes no responsibility for errors or omissions. Neither is any liability assumed for damages resulting from the use of the information contained herein. All instructions and diagrams have been checked for accuracy and ease of application; however, success and safety in working with tools depend to a great extent upon individual accuracy, skill, and caution. For this reason, the Seller is not able to guarantee the result of any procedure contained herein. Nor can they assume responsibility for any damage to property or injury to persons occasioned from the procedures. Persons engaging in the procedures do so entirely at their own risk.

Serial Number _____
Date of Purchase _____
Purchased Form _____

RETAIN THIS INFORMATION FOR FUTURE USE

UNPACKING

Remove the scale base with the platform cover, the column with weigh beam headpiece, and the hardware kit from the shipping carton. After removing from the carton, check for any damage that may have occurred during shipment. Note that the purchaser is responsible for filing all claims for any damages or loss incurred during transit. *Keep and use the original carton and packing material for return shipment if it should become necessary.*

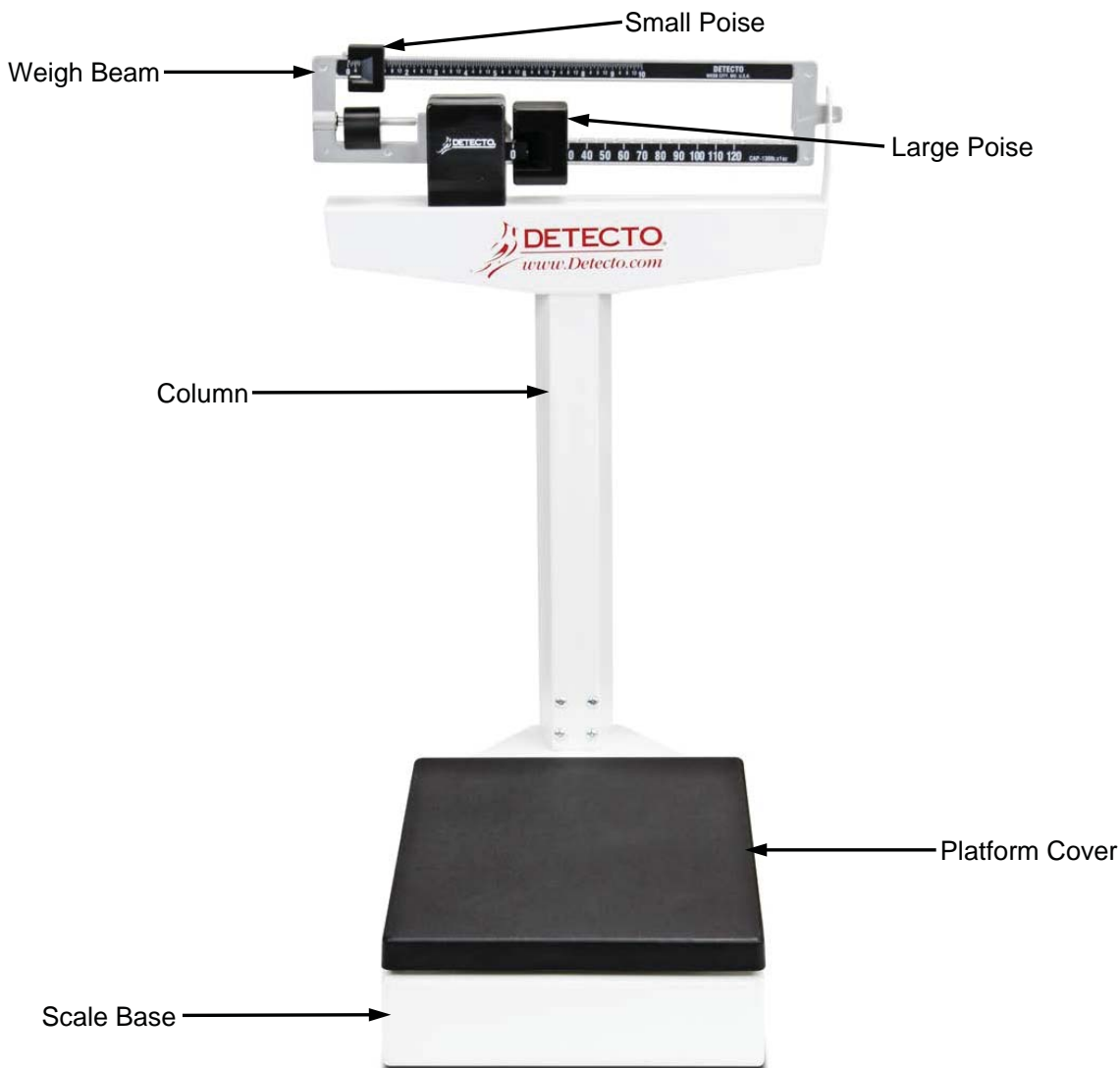

SPECIFICATIONS

Models:	4570	4520/4520B	4527PK
Capacity:	130 lb x 1 oz	450 lb x 4 oz	440 lb x 4 oz or 200 kg x 100 g
Platform Size:	14.75" x 10.75" (37.5 x 27.3 cm)		

SCALE ASSEMBLY

The Detecto 4500 Series Platform Mechanical Scale comes partially assembled. The following components require assembly:

- Column
- Draft Rod

Tools required:

- Phillips head screwdriver
- Wrench (included)

1. Set the scale base on a table or other assembly area free from traffic and obstructions.
2. Remove the cable tie that secures the draft rod during transit (shown in Figure 1).



Figure 1. - Remove cable tie securing draft rod in column

3. Insert the column onto the scale base (shown in Figure 2), ensuring that the DETECTO logo on the weigh beam faces the scale base.

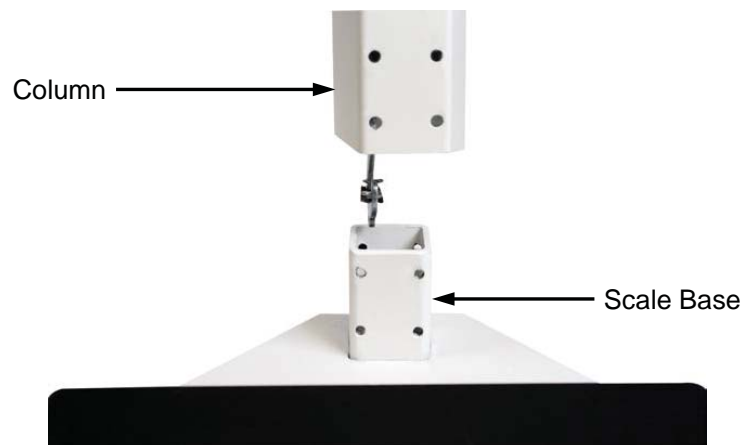

Figure 2. - Insert column onto scale base

SCALE ASSEMBLY, CONT.

4. Using a Phillips screwdriver, install the eight screws and washers to secure the column to the scale base as shown in Figure 3.



Figure 3. - Install eight screws and washers to secure the column to scale base

5. Lay the scale on a table. Remove and discard the shipping tie-wrap wires on the underside of the scale base as shown in Figure 4.

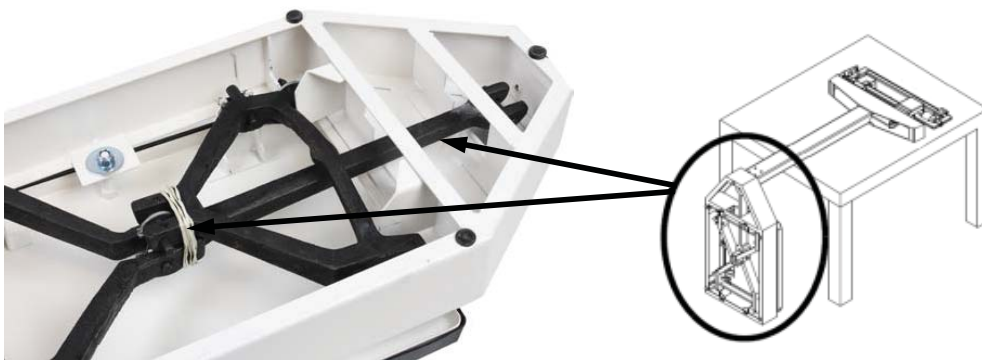

Figure 4. - Lay scale on a table to access the bottom of scale base

SCALE ASSEMBLY, CONT.

6. Insert the wrench (included) into the small hole in front of the draft rod and pull the draft rod hook with the wrench to connect it to the long lever as shown in Figure 5. The draft rod is located inside the scale column. Once the column is attached to the scale base, the draft rod must be attached to the long lever.

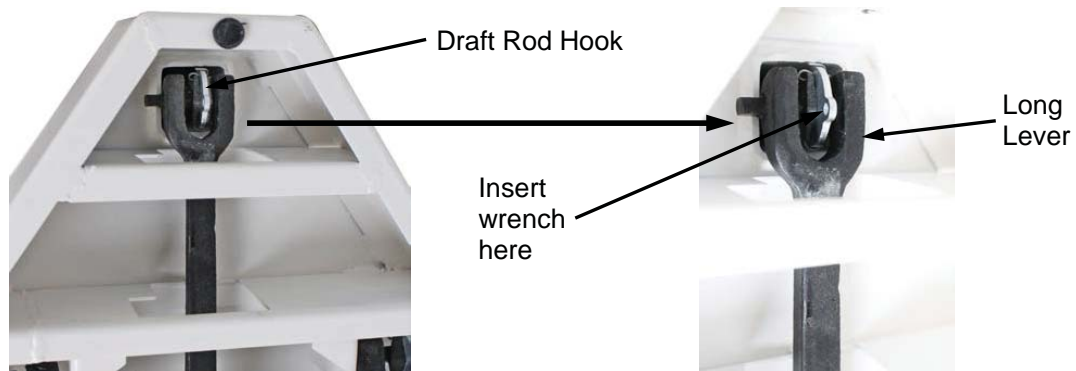

Figure 5. - Connect draft rod hook to the long lever

7. Push the long lever forward and hook the draft rod's hook onto the long lever pivot.



IMPORTANT! During shipping, a plug is installed to ensure that the shelf lever assembly stays aligned. However, the linkage may still come out of alignment. Remove the plug and then visually ensure that the shelf lever assembly linkage is centered and properly aligned. The linkage must be free-floating for the scale to weigh properly. If the scale is slightly tipped to one side, the linkage can be seen by looking up underneath the weigh beam headpiece.

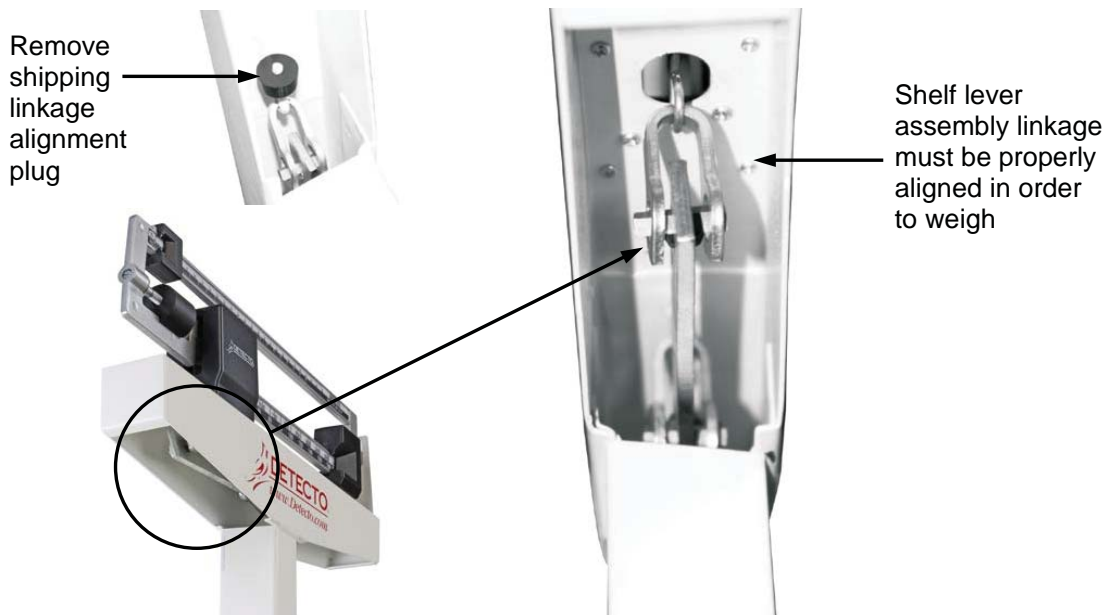

Figure 6. - View of linkage underneath weigh beam headpiece

8. Place the scale gently back on the floor.

BALANCING THE SCALE

After assembly, the scale must be balanced before using it.

1. Ensure the scale is sitting on a level surface, and slide both the small and large poise to zero (far-left position on the weigh beam).
2. Gently hold the beam pointer with your finger so it is centered within the trig loop area. Release the beam pointer and let it rise freely up or down.
3. If the beam pointer doesn't remain centered, turn the balance screw (shown in Figure 7) to the right or left using a flathead screwdriver until the beam pointer remains centered within the trig loop.



Figure 7 - View showing components for balancing scale prior to normal operation.

OPERATING THE SCALE

The following steps will guide you through the operation of your Detecto 4500 Series Platform Mechanical Scale. Refer to Figure 8 below when performing the steps.

1. Move both poise to the Zero position. Be sure the Beam Pointer is in the center of the opening in the Trig Loop.
2. Slide the Large Poise to the approximate weight. For example, if the item weighs approximately 20 pounds, slide the Large Poise to 10 pounds.
3. Place the item on the scale, and then slide the Small Poise to 5 pounds.
4. Continue sliding the Small Poise until the Beam Pointer is centered in the Trig Loop opening.
5. Read the Small Poise at the pointer and add to the 10 pounds from the Large Poise. For example, if the pointer is at 8 pounds, the item weighs 18 pounds.

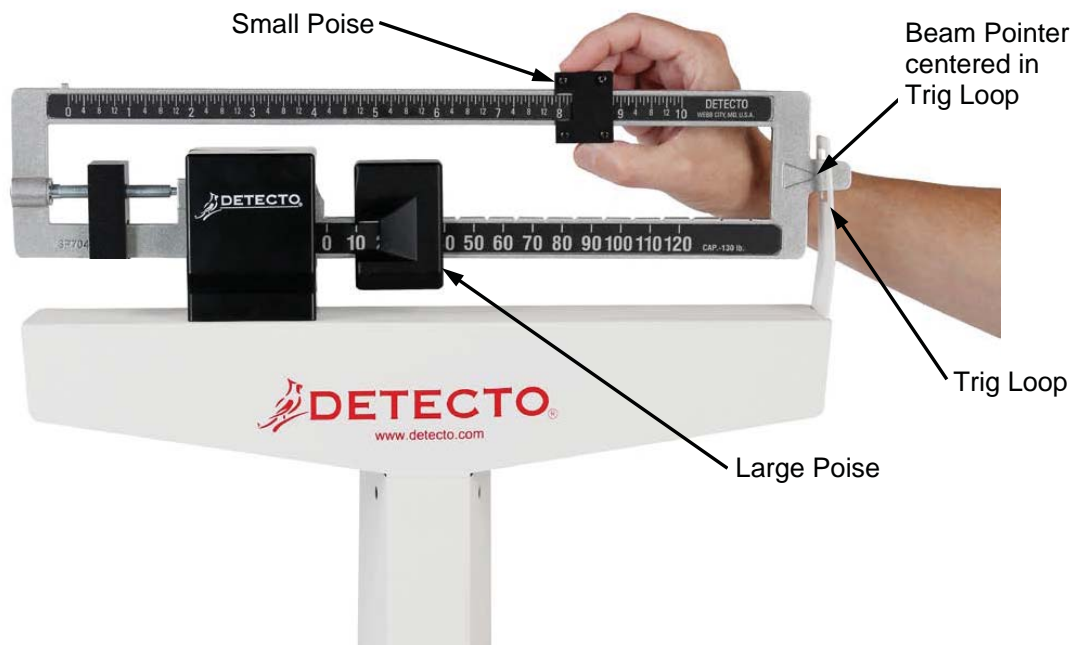

Figure 8 - View showing the procedure for weighing operation.

TROUBLESHOOTING

The Detecto 4500 Series Platform Mechanical Scale is factory-calibrated to within plus or minus 1/4 pound (0.1 kg) accuracy. For the most accurate readings, always use the scale on a hard, level surface and stand in the center of the scale platform with the weight evenly distributed. If an error occurs or seems excessive, check the following:

Problem	Possible Solution
Zero balance out of adjustment	<ul style="list-style-type: none"> The weighing beam must be balanced so the beam pointer comes to rest in the center of the trig loop when both the small and large poise are set at zero (far-left position). Refer to Figure 7 and the BALANCING THE SCALE instructions.
Beam does not move freely	<ul style="list-style-type: none"> Make sure the beam pointer is not touching the side of the trig loop, impeding its range of travel. Visually ensure that the linkage is centered and properly aligned. Occasionally during shipping, the alignment will become skewed. The linkage must be free-floating for the scale to weigh properly. If the scale is slightly tipped to one side, the linkage can be seen by looking up underneath the weigh beam headpiece.
Platform rocks excessively	<ul style="list-style-type: none"> Ensure the scale is sitting on a level surface. When you push down on any corner of the platform, you should not feel any significant rocking.
Beam does not move at all during weighing	<ul style="list-style-type: none"> Small and large poise is set higher than the person's actual weight. Reset both poise to a lower or zero weight. Make sure the draft rod is properly connected and aligned as shown in Figure 5.
Scale is out of calibration	<ul style="list-style-type: none"> Recalibrate the scale by placing a known weight on the scale and turning the balance screw until the pointer remains centered within the trig loop.

REPLACEMENT PART IDENTIFICATION

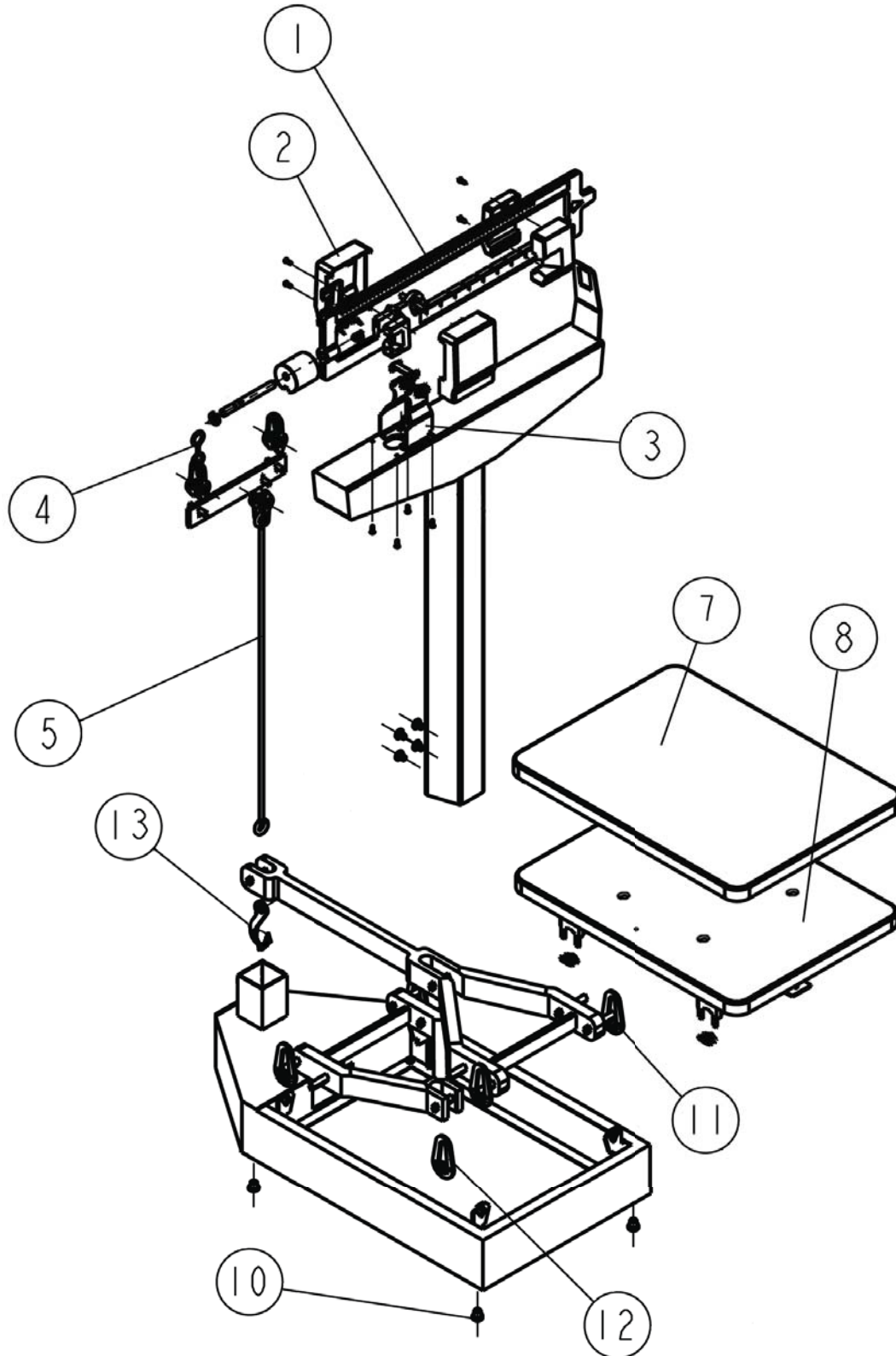

REPLACEMENT PART IDENTIFICATION, CONT.

Item	Qty.	Part Number	Description
1	1	0033-0551-0A	BEAM ASSY, 130 LB X 1 OZ, MODEL 4570
	1	0033-0536-0A	BEAM ASSY, 450 LB X 4 OZ, MODEL 4520/4520B
	1	0033-0535-0A	BEAM ASSY, MODEL 4527PK DUAL READING 440 LB X 4 OZ / 200 KG X 100 G
2	1	0033-0538-08	BEAM YOKE COVER
3	1	0033-0539-0A	BEAM YOKE ASSY
4	1	0033-0540-08	SHELF LEVER HANGER
5	1	0033-0553-0A	DRAFT ROD AND SHELF LEVER SHORT COLUMN
7	1	0033-0543-08	PLATFORM COVER LONG COLUMN
8	1	0033-0544-0A	PLATFORM AND BEARING WITH HOLES
10	1	0033-0546-08	BASE FEET
11	1	0033-0547-08	HANGER OUTER
12	1	0033-0548-08	HANGER CENTER
13	1	0033-0549-08	DRAFTROD HOOK

STATEMENT OF LIMITED WARRANTY

DETECTO warrants its equipment to be free from defects in material and workmanship as follows: DETECTO warrants to the original purchaser only that it will repair or replace any part of equipment which is defective in material or workmanship for a period of **two (2) years from date of shipment**. Detecto shall be the sole judge of what constitutes a defect.

During the **first ninety (90) days** DETECTO may choose to replace the product at no charge to the buyer upon inspection of the returned item.

After the first ninety (90) days, upon inspection of the returned item, DETECTO will repair or replace it with a remanufactured product. The customer is responsible for paying for the freight both ways.

This warranty does not apply to peripheral equipment not manufactured by DETECTO; this equipment will be covered by certain manufacturer's warranty only.

This warranty does not include replacement of expendable or consumable parts. This does not apply to any item which has deteriorated or damaged due to wear, accident, misuse, abuse, improper line voltage, overloading, theft, lightning, fire, water or acts of God, or due to extended storage or exposure while in purchaser's possession. This warranty does not apply to maintenance service. Purchased parts will have a ninety (90) day repair or replacement warranty only.

DETECTO may require the product to be returned to the factory; item(s) must be properly packed and shipping charges prepaid. A return authorization number must be obtained for all returns and marked on the outside of all returned packages. DETECTO accepts no responsibility for items lost or damaged in transit.

Conditions Which Void Limited Warranty

This warranty shall not apply to equipment which:

- A.) Has been tampered with, defaced, mishandled or has had repairs and modifications not authorized by DETECTO.
- B.) Has had serial number altered, defaced, or removed.
- C.) Has not been properly grounded according to Detecto's recommended procedure.

Freight Carrier Damage

Claims for equipment damaged in transit must be referred to the freight carrier in accordance with freight carrier regulations.

This warranty sets forth the extent of our liability for breach of any warranty or deficiency in connection with the sale or use of the product. DETECTO will not be liable for consequential damages of any nature, including but not limited to, loss of profit, delays or expenses, whether based on tort or contract. Detecto reserves the right to incorporate improvements in material and design without notice and is not obligated to incorporate improvements in equipment previously manufactured.

The foregoing is in lieu of all other warranties, express or implied including any warranty that extends beyond the description of the product including any warranty of merchantability or fitness for a particular purpose. This warranty covers only those DETECTO products installed in the forty-eight (48) contiguous continental United States.



Ph. (800) 641-2008
E-mail: detecto@cardet.com
102 E. Daugherty
Webb City, MO 64870

04/22/2024
Printed in USA
D268-WARRANTY-DET-B



DETECTO
102 E. Daugherty, Webb City, MO 64870 USA
Ph: 417-673-4631 or 1-800-641-2008
Fax: 417-673-2153
www.Detecto.com
Technical Support: 1-866-254-8261
E-mail: tech@cardet.com