



Installation Instructions for DC Digital Load Cell Retrofit Kits for MT Truck Scales

The following instructions have been provided for guidance in installing the MTX and PDX Truck Scale Retrofit Kits for Cardinal Scale's DC Digital Load Cells. It should be used in conjunction with the DC Digital Load Cell Kit Technical Manual, 8525-0353-0M, and the 225D SmartCell Weight Indicator Installation and Technical Manual, 8581-0043-0M or the 825D SmartCell Weight Indicator Installation and Technical Manual. Refer to those manuals for wiring and additional technical details.



CAUTION! Be sure all restraint systems are loosened before jacking up the scale, and that they are retightened after the installation has been completed.

1. At each section, jack up the weighbridge and remove the load cell spacers.
2. Verify that the area where the lower load cell bearing cup will be installed is clean and free of dirt and debris.
3. Place the load cells in the lower load cell bearing cups, following these guidelines:
 - Ensure the flat surface (A) of the load cell is aligned with the notch (B) in the load cell bearing cup.
 - Make sure you place the load cell bearing cup with the notch in the lower locating plate.
 - Additionally, the load cell must be correctly oriented on the scale. The notch in the load cell bearing cup **must** be placed in the lower locating plate in the direction of longitudinal scale movement (with the flow of traffic).



DC Load Cell with MTX Retrofit Components



DC Load Cell with PDX Retrofit Components

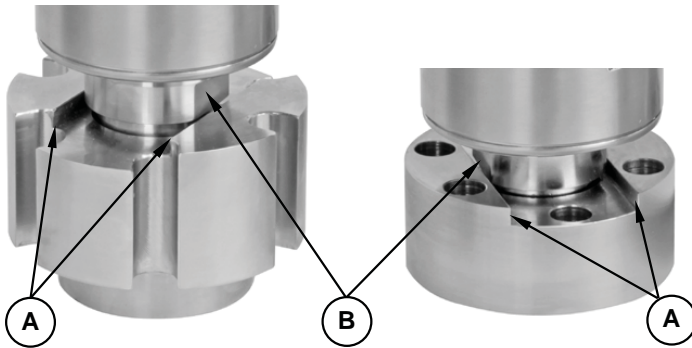

Flat surface (A) of load cell correctly installed in notch (B) of MTX load cell bearing cup.

Flat surface (A) of load cell correctly installed in notch (B) of PDX load cell bearing cup.

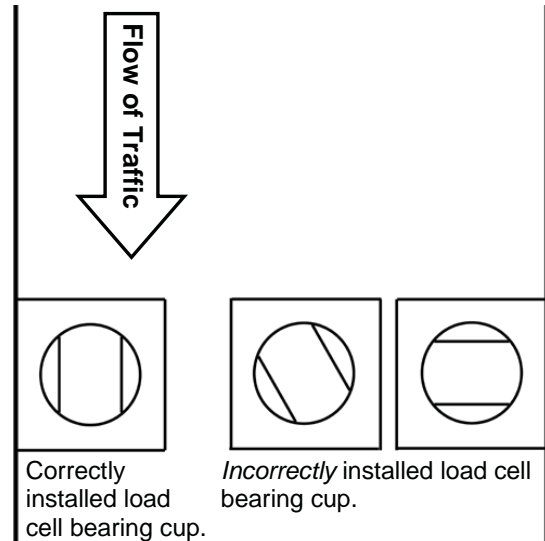

Correctly installed load cell bearing cup.

Incorrectly installed load cell bearing cup.



WARNING! Failure to install the load cell correctly in the load cell bearing cup and to ensure the notched load cell bearing cup is properly oriented in the lower locating plate will result in damage to the load cell and void the warranty!

NOTE: The load cell bearing cups are provided with O-ring seals to ensure the cleanliness of the bearing surfaces, and to ensure the bearing buttons are properly centered on the bearing surface. Should the cups become separated from the load cells, first lubricate the O-ring, then using a small wire to break the air seal on the O-ring, press the load cell bearing button back into the load cell bearing cup, and then remove the wire.

4. Lower the weighbridge in place and verify that the load cell bearing cup is seated on the top plate and that the load cell is plumb (*within 2 degrees in all directions*).

5. When all load cells are in place, verify that the scale weighbridge is properly located laterally and longitudinally. Verify that all load cells are vertical (*plumb, within 2 degrees in all directions*). If any are not plumb, jack up the scale at that cell, and reposition the cell. Care should be exercised to ensure that when the process is complete all load cells are vertical (plumb).
6. After repositioning the load cells, again verify that they are vertical (*plumb, within 2 degrees in all directions*) and that the weighbridge is seated on each load cell.
7. Next, verify that each load cell is carrying an equal dead load (plus (+) or minus (-) 10 percent) of the dead on the scale. If necessary, install one or more shims between the upper loading bearing cup and the weighbridge.

Checking

The check stand brackets should be set on smooth and level concrete and securely fixed to the concrete to prevent damage to the load cells and/or the scale from excessive movement of the scale weighbridge.



IMPORTANT! Cardinal Scale Mfg. Co. recommends that lateral and longitudinal checking limits be adjusted to $\pm 3.2\text{mm}$ (1/8 in) clearance.

Dimensions of Load Cell and MTX Retrofit Cups

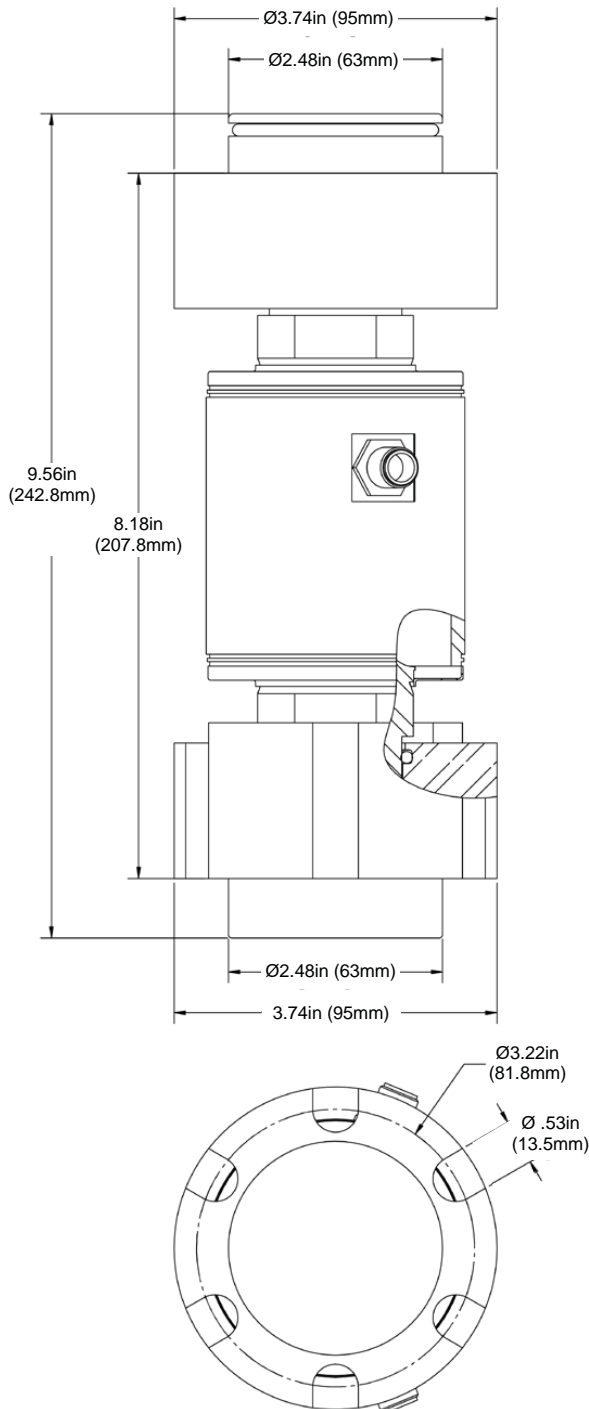

Dimensions of Load Cell and PDX Retrofit Cups

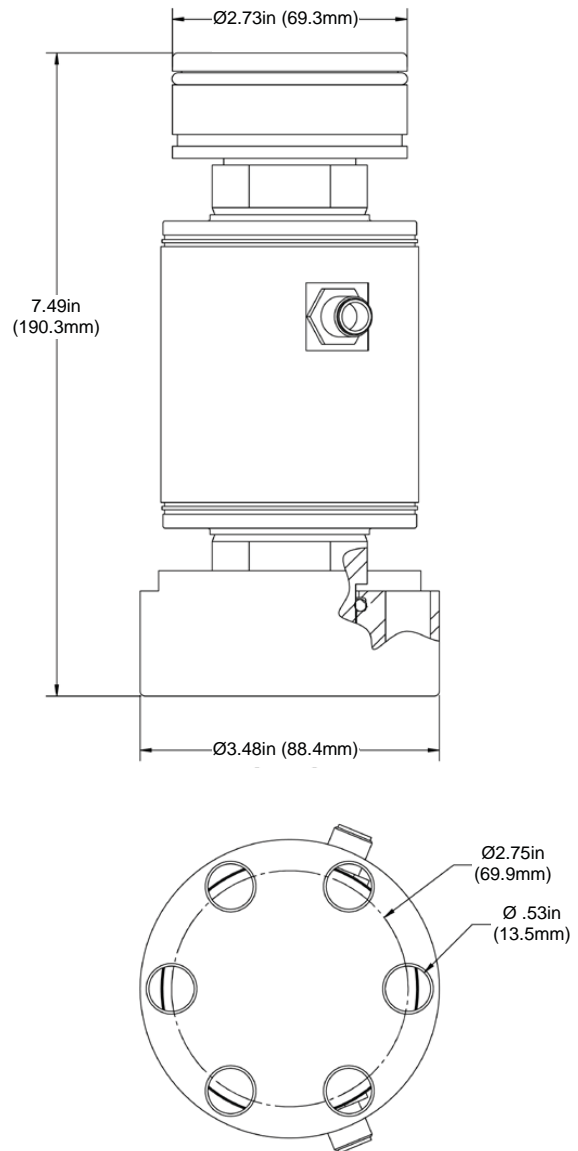

Cardinal Scale Mfg. Co.

102 E. Daugherty, Webb City, MO 64870 USA

Ph: 417-673-4631 or 1-800-641-2008

Fax: 417-673-2153

www.cardinalscale.com

Technical Support: 1-866-254-8261

E-mail: tech@cardet.com