



**PSC Series
Precast Concrete Deck
Truck Scale
Installation Manual**



8525-M335-O1 Rev A
09/12

203 E. Daugherty, Webb City, MO 64870 USA
Ph: 417-673-4631 • Fax: 417-673-2153
www.cardinalscale.com

Printed in USA

Technical Support: Ph: 866-254-8261 • tech@cardet.com

TABLE OF CONTENTS

Section I

Introduction	Page 1
Site Preparation Requirements	Page 1
Electrical Power	Page 1
AC Power Fluctuations	Page 2
Power Source	Page 2
Voltage	Page 3
Frequency	Page 3
Grounding	Page 3
AC Neutral	Page 3
Safety Considerations	Page 4
Lightning Protection	Page 4
Heating and Cooling	Page 4
Scale Site	Page 4

Section II

PSC Installation	Page 6
Foundation Verification	Page 6
Grout Plate Installation	Page 6
Bridge Module Installation	Page 7
Check Stand Bracket	Page 7
Stabilizer Installation	Page 7
Load Cell Installation	Page 8
Grout Installation	Page 10
Grounding Installation Instruction	Page 11

Section III

Calibration	Page 12
Trimming Individual Load Cells	Page 12
Section-Sealing at Time of Installation	Page 16
Section-Sealing Using Test Truck	Page 17
Section-Sealing with Test Weights	Page 17

Section IV

Troubleshooting	Page 19
---------------------------	---------





IMPORTANT! If your scale is equipped with access ways, such as manholes, it is the user's responsibility to provide proper protection, such as barriers, during the time they are opened or removed.

TABLE OF ILLUSTRATIONS

Title

Figure No. 1 – Power Outlet	Page 1
Table A – Power Outlet Requirements	Page 1
Figure No. 2 – Power Outlet Wiring	Page 2
Table B – Power Conditioning Device	Page 3
Figure No. 3 – Grout Plate Installation	Page 6
Figure No. 4 – Bridge Module Attaching	Page 7
Figure No. 5 – Load Cell Assembly Install	Page 8
Figure No. 6 – Load Button	Page 8
Figure No. 7 – Grout Placement	Page 10
Figure No. 8 – Caution Label and SENS Jumpers	Page 13
Figure No. 9 – Load Cell Adjustment Pot and Enable Jumper	Page 14
Figure No. 10 – Section-Sealing Pots	Page 16
Table C – Section-Seal Adjustment Chart	Page 17
Table D – Load Cell Output Voltage Chart	Page 20

<p>Serial Number _____</p> <p>Date of Purchase _____</p> <p>Purchased Form _____</p> <p>_____</p> <p>_____</p> <p>RETAIN THIS INFORMATION FOR FUTURE USE</p>

<h2>PRECAUTIONS</h2> <p>Before using this instrument, read this manual and pay special attention to all "WARNING" symbols:</p>	
	
IMPORTANT	ELECTRICAL WARNING

FCC COMPLIANCE STATEMENT

This equipment generates uses, can radiate radio frequency, and if not installed and used in accordance with the instruction manual, may cause interference to radio communications. It has been tested and found to comply with the limits for a Class A computing device pursuant to Subpart J of Part 15 of FCC rules, which are designed to provide reasonable protection against such interference when operated in a commercial environment. Operation of this equipment in a residential area may cause interference in which case the user will be responsible to take whatever measures necessary to correct the interference.

You may find the booklet “How to Identify and Resolve Radio TV Interference Problems” prepared by the Federal Communications Commission helpful. It is available from the U.S. Government Printing Office, Washington, D.C. 20402. Stock No. 001-000-00315-4.

COPYRIGHT

All rights reserved. Reproduction or use, without expressed written permission, of editorial or pictorial content, in any manner, is prohibited. No patent liability is assumed with respect to the use of the information contained herein.

DISCLAIMER

While every precaution has been taken in the preparation of this manual, the Seller assumes no responsibility for errors or omissions. Neither is any liability assumed for damages resulting from use of the information contained herein. All instructions and diagrams have been checked for accuracy and ease of application; however, success and safety in working with tools depend largely upon the individual accuracy, skill and caution. For this reason, the Seller is not able to guarantee the result of any procedure contained herein. Nor can they assume responsibility for any damage to property or injury to persons occasioned from the procedures. Persons engaging the procedures do so entirely at their own risk.

SECTION I

INTRODUCTION

The Cardinal PSC Series Precast Concrete Deck Truck Scale is a versatile scale that is designed to be installed above ground. All required components may be installed from the top.

This manual must be used in conjunction with certified drawings of the particular truck scale model being installed. *In case of conflict, the certified drawings will govern.*

This manual should be studied thoroughly before attempting to install the PSC Series Truck Scale. Safety should always be the prime consideration during all phases of the installation. Failure to comply with the instructions in this manual will void all warranty implied or stated.

SITE PREPARATION REQUIREMENTS

Your new Cardinal scale, as with any precision measuring instrument, requires an acceptable environment to operate at its peak performance and reliability. The purpose of this section is to explain how the user can provide such an environment.

Electrical Power

Most Cardinal instrumentation is designed to operate at 115 VAC, 50/60 Hz. Where required, the equipment may be ordered for operation at 230 VAC, 50/60 Hz. Refer to your order confirmation copy or to the equipment nameplate, if you are not certain for which voltage level your scale is configured.

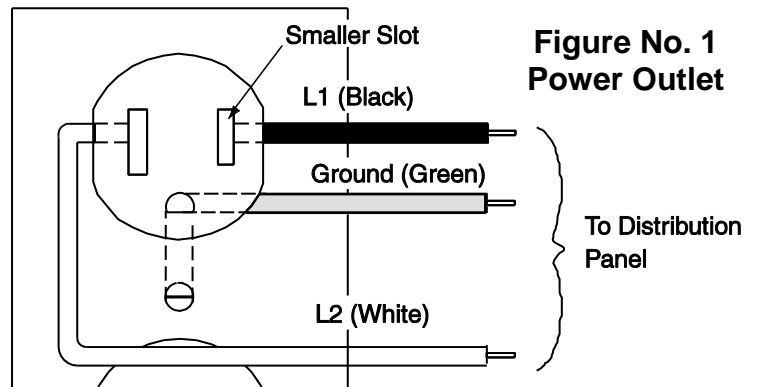

Your weighing system will require one or more power outlets. Refer to Table A to determine the number of power outlets necessary for your system. These outlets should be of the grounded, polarized type as shown in Figure No. 1. One additional outlet is recommended to allow a source of power for test equipment to be used during installation and service.

Table A – Power Outlet Requirements

Device	Outlets Required
Weight-Indicating Instrument	1
Printer	1
Fill Control Console	1
Traffic Control Console	1
Regulating Transformer*	1
Computer	1

*This piece of optional equipment eliminates the need for an outlet for the weight-indicating instrument and power supply-section seal J-box, depending on the type of regulating transformer.

Electrical Power, Cont.

Figure No. 2 illustrates typical wiring from the distribution panel to the power outlets used for the weighing system.

Power outlets should be on a separate circuit from the distribution panel. This circuit should be dedicated to the exclusive use of the weighing system. The power wiring should conform to local electrical codes. Services of a qualified contractor and approval by the local building inspector generally will assure compliance with this code.

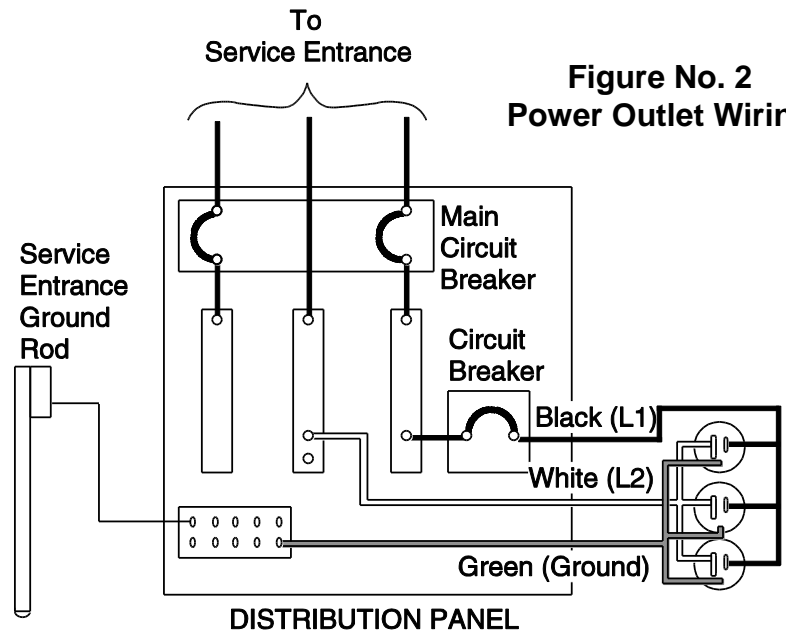

Figure No. 2
Power Outlet Wiring

To prevent electrical noise interference, make certain that all other wall outlets for use with vacuum cleaners, lighting, calculators and other equipment are on circuits separate from that used for the weighing system.

AC Power Fluctuations

Your Cardinal Weighing System uses one or more microcomputer systems. Many of the problems associated with computer operations are caused by fluctuations in the AC power system. Electrical noise, power interruptions and lightning effects from the commercial power line may enter the weighing system and cause equipment failures.

Many of the disturbances that can seriously affect the operation of a weighing system originate within the building itself. These disturbances result from switching heavily inductive loads, such as welders, motors and solenoids. These sources of disturbances must be identified and steps taken to prevent possible adverse effects on the operation of the weighing system. Examples of available alternatives include isolation transformers, power regulators, uninterruptible power supplies, or simple line filters.

Power Source

The power source should have sufficient capacity to supply the weighing system load. Consideration should be given to adding extra capacity to provide for the additional loads caused by expansion of your system. Make certain this source is independent of other loads (i.e., air conditioning and heating equipment, convenience outlets, lighting or office equipment, which can cause disturbances). A separate line back to the distribution panel usually provides suitable power. Make certain that a properly sized circuit breaker is installed in this line to safeguard against accidental short circuits.

Table B provides some basic guidelines in selection of a power-conditioning device, should it be necessary to use one. Remember that this is only a guide and that a qualified technician should be consulted for determination of the type of device suited to your application. All of the types listed are available in various sizes from Cardinal Scale or may be purchased locally.

Table B – Power Conditioning Device

Type	PROVIDES PROTECTION AGAINST			Cost
	Outages	Transients	Fluctuations	
Uninterruptible Power Supply	✓	✓	✓	High to Moderate
Voltage Regulator		✓	✓	Moderate
Isolation Transformer		✓		Low to Moderate
Line Filters		✓		Low

Voltage

Voltage (steady state) variations shall not exceed plus (+) 10 percent or minus (-) 15 percent of the nominal value 115 VAC (plus or minus 8 percent for 230 VAC).

Transient variation (step or slope) changes of plus (+) or minus (-) 20 percent on the nominal value shall exist no longer than 0.1 second and occur no more than once every 10 seconds.

Frequency

The equipment is designed to operate at a nominal 50/60 Hertz unless specified otherwise on the equipment nameplate. The steady state harmonic distortion should be equal to, or less than, 6 percent of the fundamental frequency amplitude.

Grounding

A ground wire must be included with the power conductors (phase or L1 and neutral or L2 wires) in the run from the distribution panel to the weighing system power outlets. The size of the ground wire must comply with The National Electrical Code or local electrical code. The ground conductor must be securely bonded to the building's grounding electrode conductor. Refer to Grounding Installation Instructions for the scale and instrument.



CAUTION! A broken or high resistance safety ground is a potentially lethal situation. Because of line-to-chassis voltage potential, it is possible to receive a shock by touching the equipment if the green wire ground is not intact. Please be sure proper grounding is connected!

AC Neutral

The AC neutral must not be confused with protective (equipment chassis) ground. As protection for personnel, the protective equipment ground (the green wire in power line wiring) prevents the build-up of dangerous voltages on equipment. It ensures that a short circuit between L1 and the enclosure draws enough current to trip the circuit breaker immediately, rather than raising the voltage on the enclosure to a dangerous level. Do not substitute the neutral wire for the protective ground.

Safety Considerations

Safety must be a consideration in the selection of a location for your weighing system. DO NOT locate your system in an area where flammable or explosive materials are stored or processed unless your equipment is furnished in special explosive-proof enclosures. The equipment should be placed where it does not interfere with entry to or exit from the room. Periodic reviews should be made to make certain that the installation remains safe.

Lightning Protection

In areas subject to lightning strikes, certain steps must be taken by the customer to minimize the potential for lightning damage. These steps consist of the installation of lightning arresters as required by Article 280 of The National Electrical Code, the installation of a scale grounding system as described in Grounding Installation Instructions, and other surge arresting devices.

Heating and Cooling

Most standard Cardinal weighing system instrumentations are designed for the office environment. Such an environment is free of excessive dust and moisture and provides a comfortable temperature. In general, weighing equipment will perform well over a temperature range of 14° to 104° F. Some types of instruments and special systems will perform over a much wider range of temperatures.

In order to keep equipment cooling requirements to a minimum, the equipment should be placed out of direct sunlight and in an area where air is free to flow around all sides of the system enclosure(s). Make certain that the enclosure is not in line with a heating or cooling vent. Such a location will subject the instrument to sudden temperature excursions and may result in an unstable weight reading.

Care should be exercised by providing a relatively dust-free environment for operation of the printer. Accumulations of dust and dirt within the printer act as abrasives; also as insulators that reduce the dissipation of heat from internal components. Accumulated dust and dirt can result in premature failure.

Scale Site

The site selected for installation of the scale should provide easy access, satisfactory soil bearing capacities, adequate drainage, and be within sight of the system operator. Refer to the foundation or pit drawings furnished for soil bearing requirements.

A common source of problems is the accumulation of water under and around the scale. In spite of the best water proofing techniques, prolonged exposure to water will result in erratic weight readings and may permanently damage the scale. In areas subject to water accumulation, an inexpensive alternative is to install a sump pump to remove excess water. Remember that power wiring for the sump pump must be contained in a conduit apart from the load cell conduit and separated from it a minimum of 24 inches.

Scale Site, Cont.

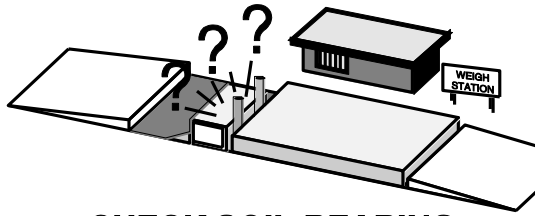

CHECK SOIL BEARING CAPABILITY

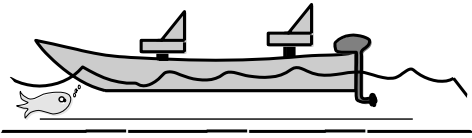

PROVIDE ADEQUATE DRAINAGE

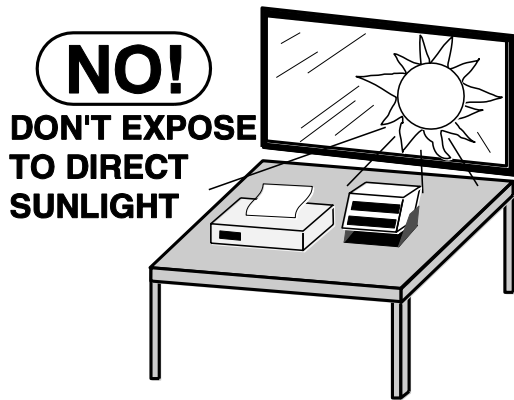

NO!
DON'T EXPOSE TO DIRECT SUNLIGHT

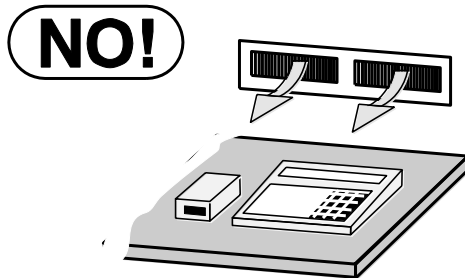

NO!
DON'T PLACE IN FRONT OF HEATING/COOLING VENTS

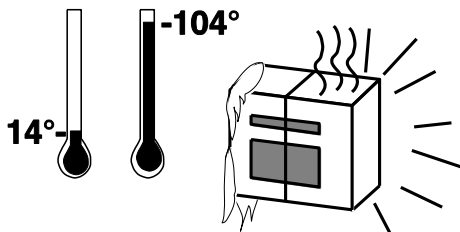

NO!
DON'T EXPOSE TO TEMPERATURE EXTREMES

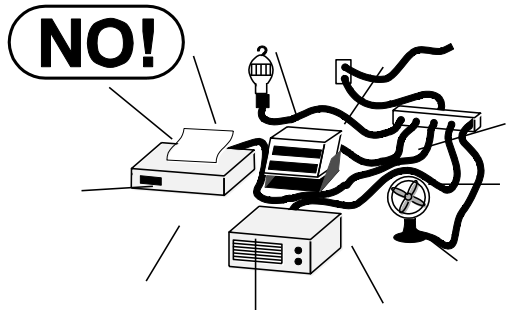

NO!
PROVIDE GOOD, SAFE GROUND AND CLEAN AC POWER



NO!
PROVIDE ADEQUATE PROTECTION TO MINIMIZE LIGHTNING DAMAGE

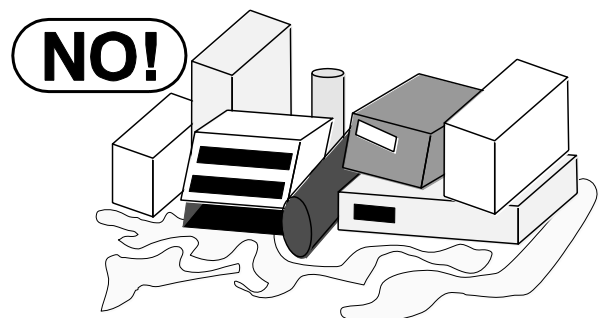

NO!
KEEP THE AREA AROUND THE SCALE CLEAR TO PROVIDE ADEQUATE AIR CIRCULATION

SECTION II

PSC INSTALLATION

At this point, the foundation should be in place as specified on the certified foundation drawing.

FOUNDATION VERIFICATION

Begin the installation procedure by verifying that the following items have been cast in the concrete foundation and have been properly located per the certified foundation drawing:

- Anchor bolts
- Coping angles
- Ground rod
- Restraint assembly
- Transmission cable conduit



WARNING: Permanent damage may occur if the truck scale is not properly installed.

GROUT PLATE INSTALLATION

Install the grout plate assemblies insuring that the top of the plate is 1 foot, 15/16 inch below the approach ramps. This will allow for a nominal 1 inch of grout. Refer to Figure 3.

The grout plate assemblies should be located as shown on the certified assembly drawings. The top of each grout plate assembly should be level within 1/32 inch across the surface of the plate.

The top surface of each grout plate assembly should be at the same elevation within 1/4 inch from the highest plate to the lowest plate. A transit is recommended to confirm the elevation. The scale is to be completely installed prior to grouting.

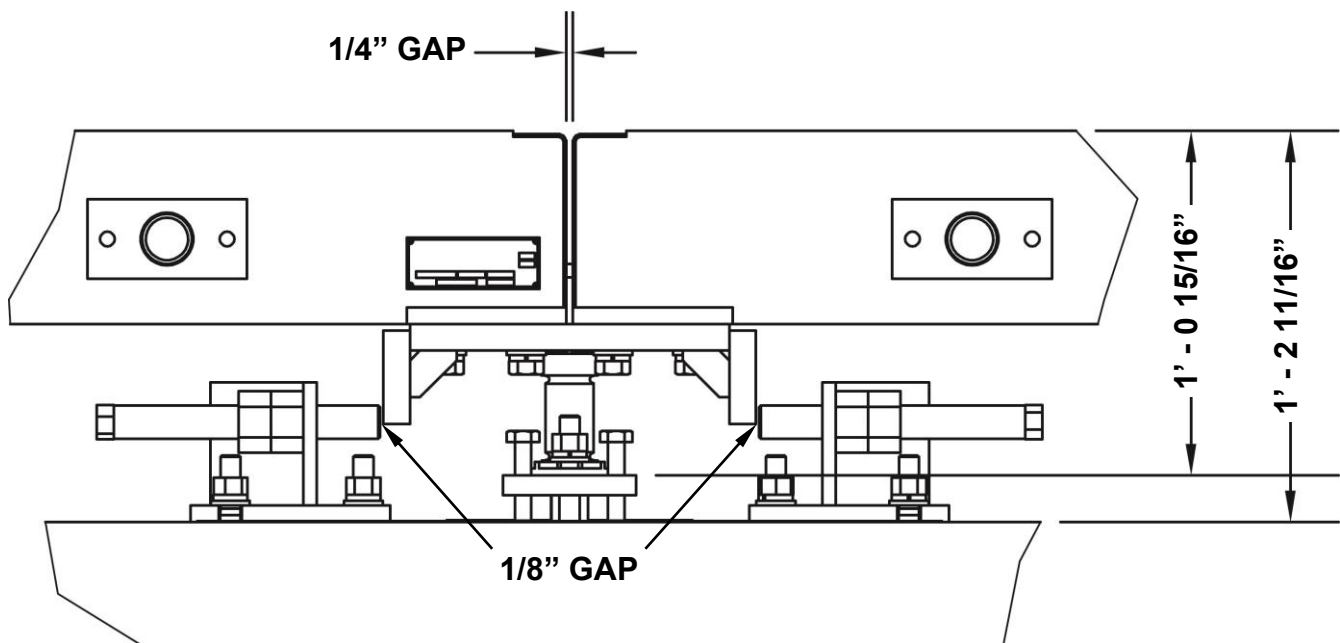
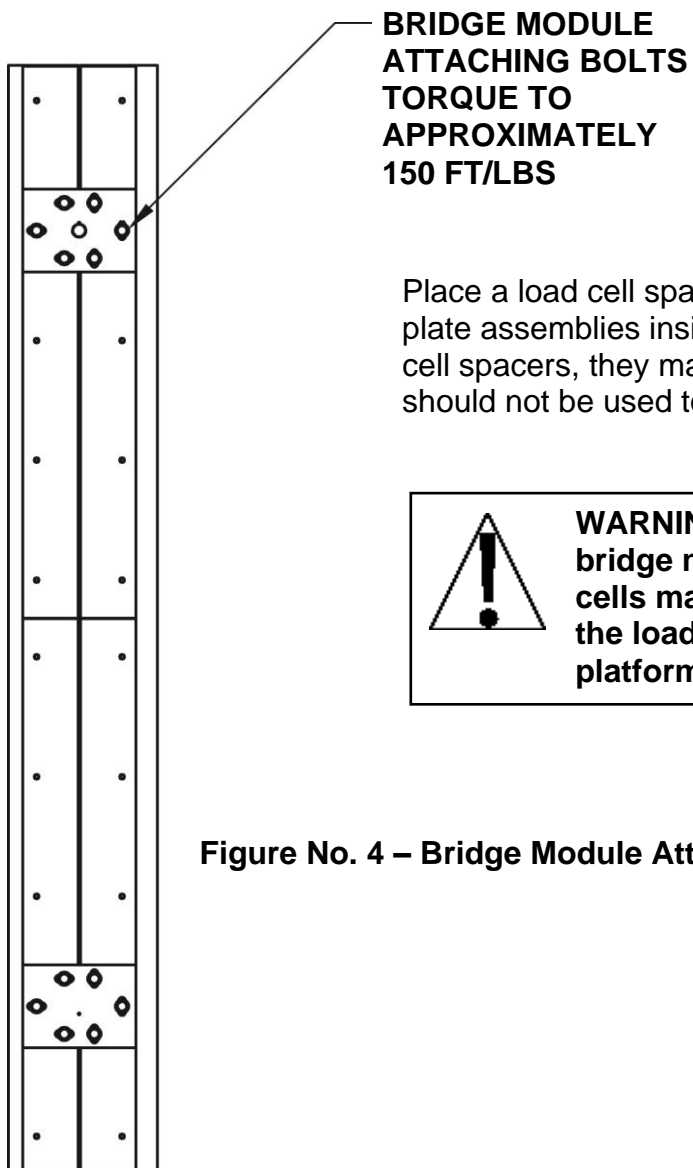

Figure No. 3 – Grout Plate Installation

BRIDGE MODULE INSTALLATION



**BRIDGE MODULE
ATTACHING BOLTS
TORQUE TO
APPROXIMATELY
150 FT/LBS**

Place a load cell spacer (load cell substitute) on each of the grout plate assemblies inside the locating plate. If you do not have the load cell spacers, they may be obtained from Cardinal Scale. Load cells should not be used to install the bridge modules. Refer to Figure 4.



WARNING: Do not use the load cells to install the bridge modules. Permanent damage to the load cells may result. Personal injury can also result as the load cells do not provide a stable installation platform until all stabilizer assemblies are in place.

Figure No. 4 – Bridge Module Attaching

CHECK STAND BRACKET



WARNING: The check stand brackets should not be grouted in place. They should set on smooth and level concrete with preset anchor bolts. Should the lateral check stand brackets not be securely fixed to the concrete, damage to the load cells and/or the scale may result from excessive movement of the scale bridge.

STABILIZER INSTALLATION

Adjust lateral and longitudinal bumper bolts so that they have 1/8 inch clearance. Tighten the jam nut on the bumper bolts to lock in place as shown in Figure No. 3.

LOAD CELL INSTALLATION

NOTE: Cardinal Scale Mfg Co. recommends that the customer install protective conduit/cover for the load cell cables whenever the condition is present that can result in damage or abrasion to the load cell cables. Protection kits are optionally available through Cardinal Scale Mfg Co.

At each section, jack up the weighbridge and remove the load cell spacers. Verify that the load buttons are clean and free of dirt and debris. Lower the weighbridge in place and verify that the load cell is centered on the top and bottom load button and that the load cell is plumb, refer to Figure 5.

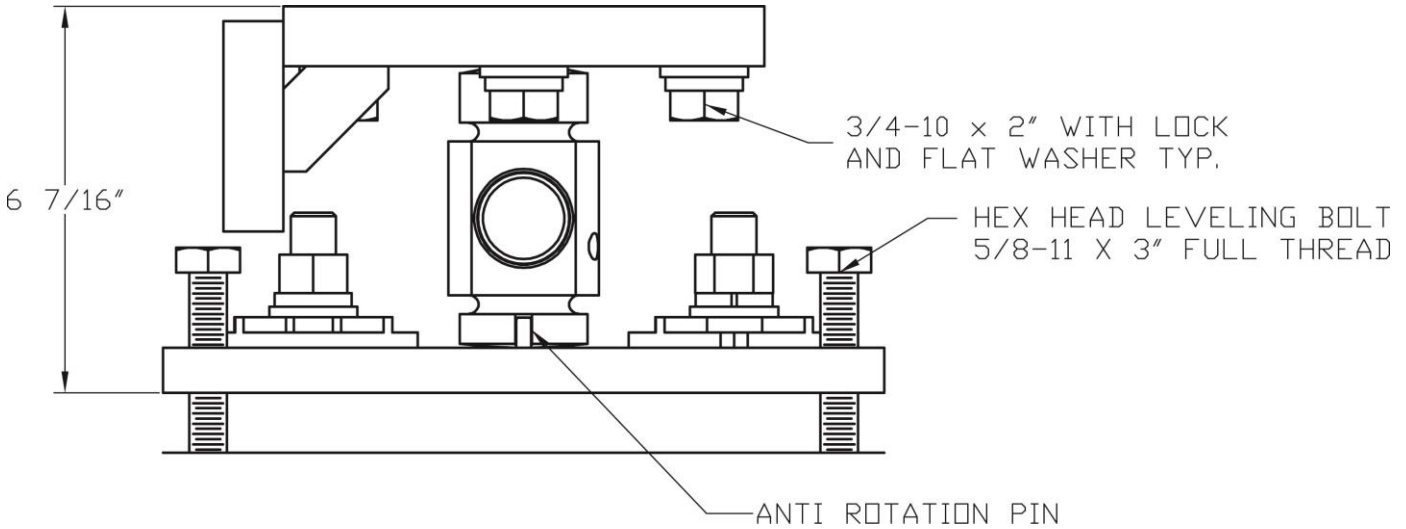
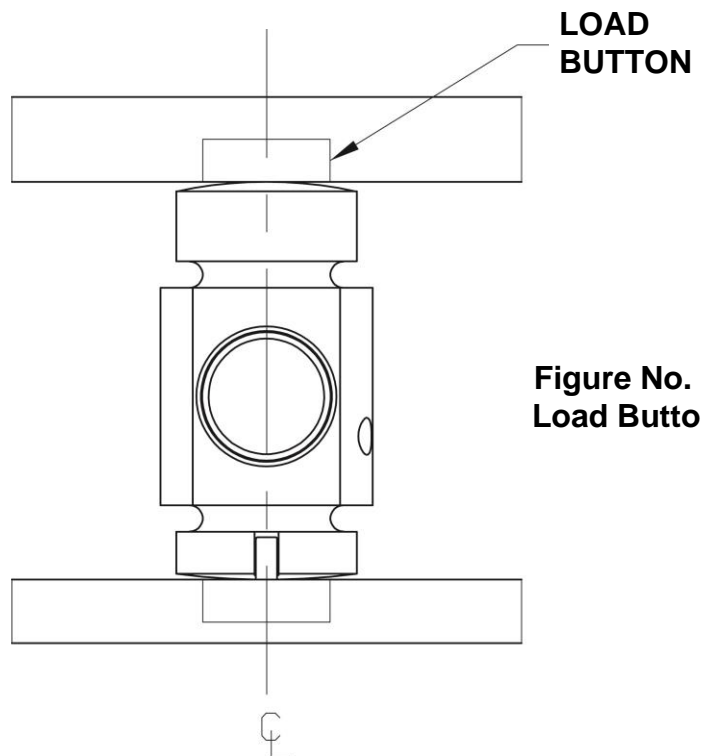

Figure No 5 – Load Cell Assembly Install

When all load cells are in place, verify that the scale is properly located laterally and longitudinally. Verify that all load cells are vertical (plumb). If any are not plumb, jack up the scale at that cell, and reposition the cell. Care should be exercised to ensure that when the process is complete, all load cells are vertical (plumb).

After all load cells are in place and vertical, verify that each load cell is taking its share of the dead load of the scale. This can best be done by measuring the output voltage of each individual load cell using a 3 1/2 digit DVM.

When the load cell wiring is complete, apply power to the system.



**Figure No. 6
Load Button**

Disconnect all RED load cell wires (+SIG) and all WHITE load cell wires (-SIG) on the Universal Section Seal/Trim box PC board 3502-D588-0A. Note that sections 4, 5 and 6 (depending on how many sections are in the scale) are wired with an additional cable that effectively extends the length of the load cell cables. This is a multi-conductor cable made up of shielded pairs of wires. You must refer to the wiring blueprint to correctly wire each end of this cable. Keep the wire pairs separated so they do not get mixed. On the blueprint, a dotted line encircling two wires indicates a wire pair. In all cases, the +SIG and -SIG wires are disconnected to be measured. Touch the +SIG wire to the RED test lead and the -SIG wire to the BLACK test lead when measuring the load cell output voltage.

Check each load cell in turn to determine which cells might be taking too much or too little load. A higher voltage indicates a load cell with a greater load.

Adjust the leveling bolts in the appropriate grout plate until all load cell output voltages are within 1 millivolt or less of each other. A concrete deck PSC Scale will have near 3.2 millivolts from each center section and about half that from each of the two end sections.

Adjust the two load cells of each section to agree with each other as closely as possible. Within 1/2 millivolt is recommended. A little extra effort here is time well spent since it has a direct bearing on the ease and accuracy of section-sealing the scale, as well as long term satisfaction of the operation of the scale.

Refer to Grout Plate Installation to insure that the scale deck is level - within 1/4 inch.



WARNING! All load cells must be absolutely vertical and sharing a portion of the scale dead load. If this is not true, weighing inaccuracies will occur.

GROUT INSTALLATION

When all of the above installation procedures have been completed and verified, the load cell grout plate should be grouted in place permanently, prior to loading the scale.



CAUTION! All load cells must be mounted in a vertical (plumb) position prior to grouting.

A free-flowing, non-shrinking epoxy type grout should be used. The grout should have bearing capabilities in excess of 5000 PSI. Five Star Epoxy Grout or equal is recommended. Follow carefully the manufacturer's recommendations for mixing and cure time of the grout.

A wood or metal frame must be used to contain the grout around the grout plate. The frame should be approximately one inch larger than the grout plate on each side. The free-flowing epoxy grout can then be poured into the frame, allowing it to flow completely under the grout bearing plate. Care should be exercised to ensure that no voids occur under the grout plates. See Figure 7.



WARNING! Do not load the scale until grout is installed under the grout plates and the grout is completely cured. The leveling bolts will not support any load beyond the dead weight of the scale.

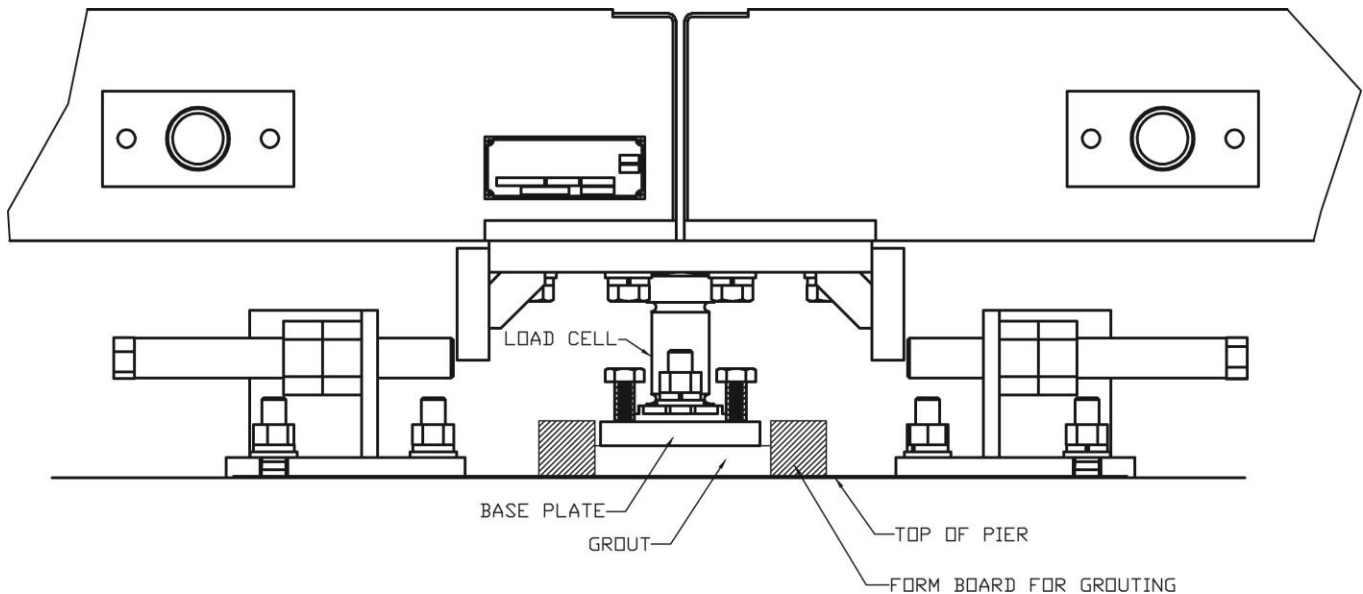

Figure No 7 – Grout Placement

GROUNDING INSTALLATION INSTRUCTION

1. The ground rod shall be imbedded below permanent moisture level at least 8 feet (2.44 m) where practicable. Where rock bottom is encountered at a depth of less than 4 feet (1.22 M), the ground rod shall be buried in a horizontal trench.
2. Connect the Universal Section Seal/Trim box and weight indicating instrument ground lug, to the ground rod with No. 10 AWG insulated stranded copper wire.
3. Install ground wire 2970-B013-0A.

SECTION III

CALIBRATION

If, after test loading the scale, it is determined that adjustments are required, follow the procedure below. This section describes the procedure necessary to calibrate a Cardinal PSC Motor Truck Scale. This information DOES NOT apply to digital load cells, hydraulic load cells, or digital Junction Boxes (iCan). Refer to the applicable manuals for calibration instructions.

1. Before any adjustments are made, turn on power to the digital weight indicator and, when applicable, the power supply section-seal box.
2. Drive a test truck across the scale at least three times in each direction prior to calibrating the scale.
3. Before any sealing can be done, the weight indicator must be calibrated to the scale. A division size of 10 lbs should be selected and the auto-zero function turned off. Refer to the Weight Indicator Installation and Technical Manual.

TRIMMING INDIVIDUAL LOAD CELLS

The pots are adjusted for balance at the factory before shipment and should never be readjusted unless testing shows the necessity. Due to the consistent quality of the load cells, it is unlikely that trim adjustment will be necessary. Provisions have been made to trim (or balance) the output of the each load cell that make up a section of the scale. A few governing bodies require that a side to side test be made to determine if the two load cells making up a section are within legal tolerance of each other. Do the following BEFORE section sealing the truck scale.

TRIMMING INDIVIDUAL LOAD CELLS, CONT.

NOTE: If the Load Cell/Section Trim Box was not received with the scale:
Refer to Figure No. 8 for the following steps.

1. Remove the caution label and locate the screw holding the metal cover to the board.
2. Remove the screw and metal cover from the board.
3. Close the board SECTION ENABLE jumpers for all **sections** to be connected to load cells.
4. Open the board SECTION ENABLE jumpers for all unused **sections**.
5. Close SENS jumpers J13 & J14 if the load cells are wired directly to the trim board.
6. Open \pm SENS jumpers J13 & J14 if the load cells are **NOT** wired directly to the trim board and the P14 \pm SENS terminals are wired to the L.C. J-BOX.
7. Turn all **load cell** and **section** pots fully Clockwise (CW), 25 turns or until an audible click is heard.
8. Turn all pots six (6) turns Counter-Clockwise (CCW).
9. Replace the metal cover.

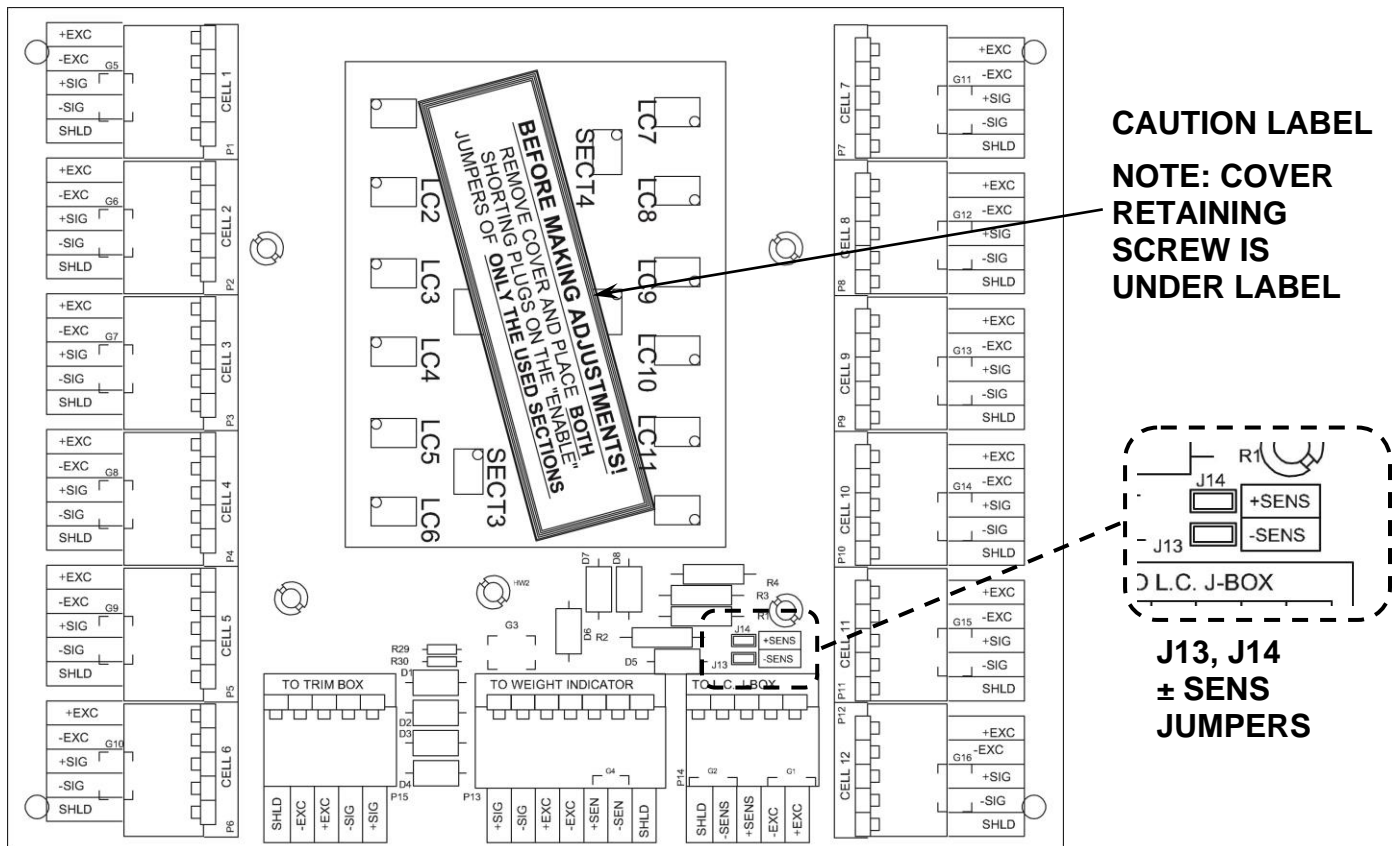

Figure No. 8 – Caution Label and SENS Jumpers

TRIMMING INDIVIDUAL LOAD CELLS, CONT.

1. On a Cardinal PSC scale, all adjustments are made on the combination section seal/trim junction box in the scale house.
2. On a Cardinal PSC scale, all adjustments are made on the combination section seal/trim junction box in the scale house.
3. On the combination section seal/trim box, the trim adjustment pots are placed closest to the cell terminal blocks. See Figure No. 9.

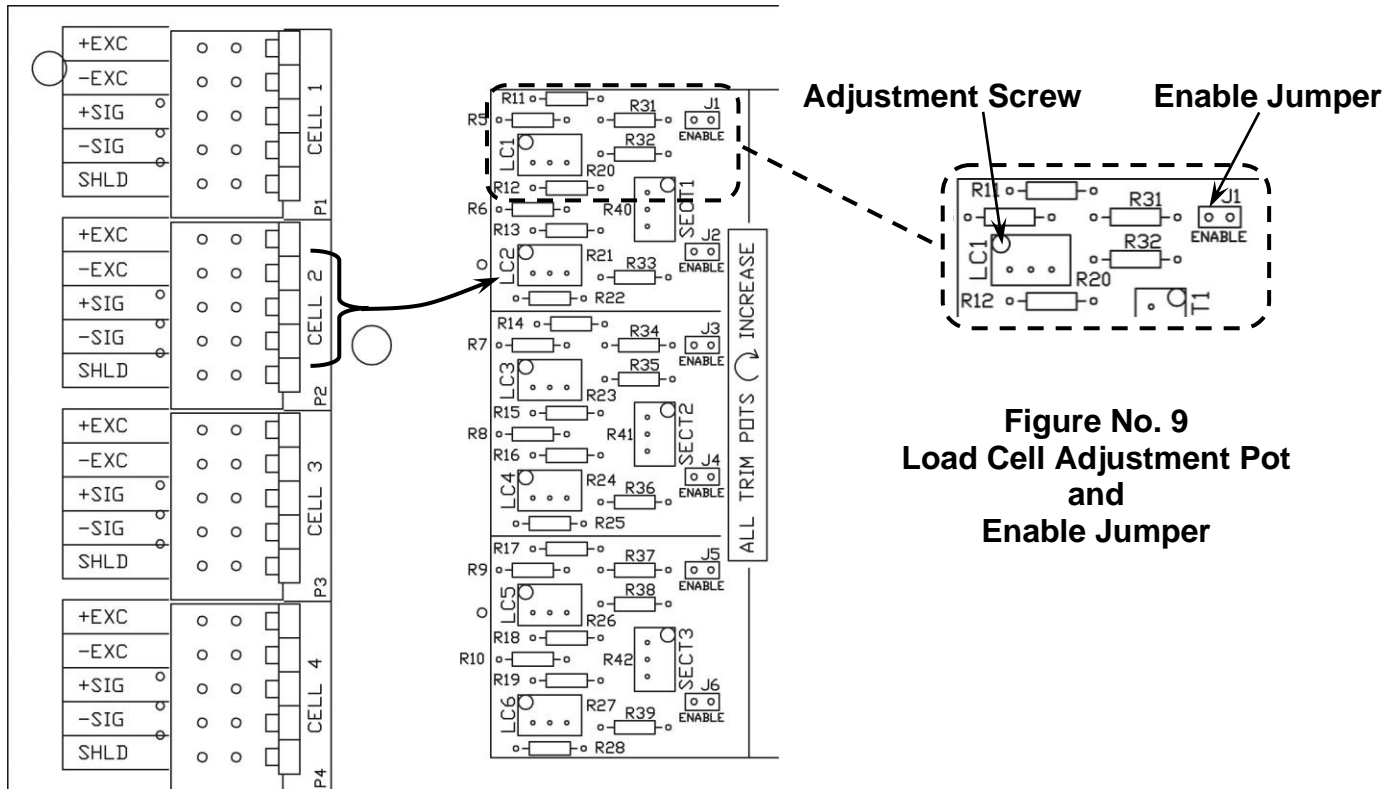

Figure No. 9
Load Cell Adjustment Pot
and
Enable Jumper

4. Silkscreened in the center of the trim section is a diagram that shows the rotation direction of the pot adjustment screw to increase the output voltage level of the load cells affected by its associated pot. See Figure No. 9. For example, Clockwise (CW) rotation of the adjustment screw on pot R20 will raise the signal level of load cell 1; Counter-Clockwise (CCW) rotation will lower the signal level of load cell 1.

When testing indicates that there is a difference in the displayed weight of the two load cells, the load cell with the lowest weight reading should be adjusted up-scale to agree with the other load cell. Two to four turns of the adjustment screw on the pot in the appropriate direction is a good preliminary adjustment. You may or may not see a change in the displayed weight, but a change has been made.

Remove the test weights from the scale and re-zero the weight indicator. Now place the test weights on each load cell in turn to see how the load cells compare with each other. Continue to do this procedure until the two load cell displays agree.

TRIMMING INDIVIDUAL LOAD CELLS, CONT.

You must remove test weights (or test cart) from the scale to re-zero the weight indicator each time an adjustment is made. It is important to do this since a zero shift can occur due to the adjustment. This shift can cause the relative displayed weights of both load cells to change.

Ignore any displayed weight changes you see when adjusting the load cell signal (output). This is due to a shift of the zero point and is NOT indicative of the true adjustment actually being made. When this occurs, the displayed weight reading from the other load cell will also change (since the zero point has changed) and the weight readings from the two load cells will be moving closer together. When they agree, adjustment is complete.

SECTION SEALING AT TIME OF INSTALLATION

The weight indicator should be calibrated to the scale prior to section sealing.

The section-sealing pots are found in the combination section-seal/trim junction box located near the weight indicator. Refer to Figure No. 10. Locate the pots labeled Sect1 through Sect6.

With no load on the scale deck, watch the display of the weight indicator and turn the adjusting screw of section 1 sealing pot, clockwise (CW) until the display no longer changes as the screw is turned. Now turn the adjusting screw counter-clockwise (CCW) five complete turns.

Do this to the section-sealing pot for each section of the scale.

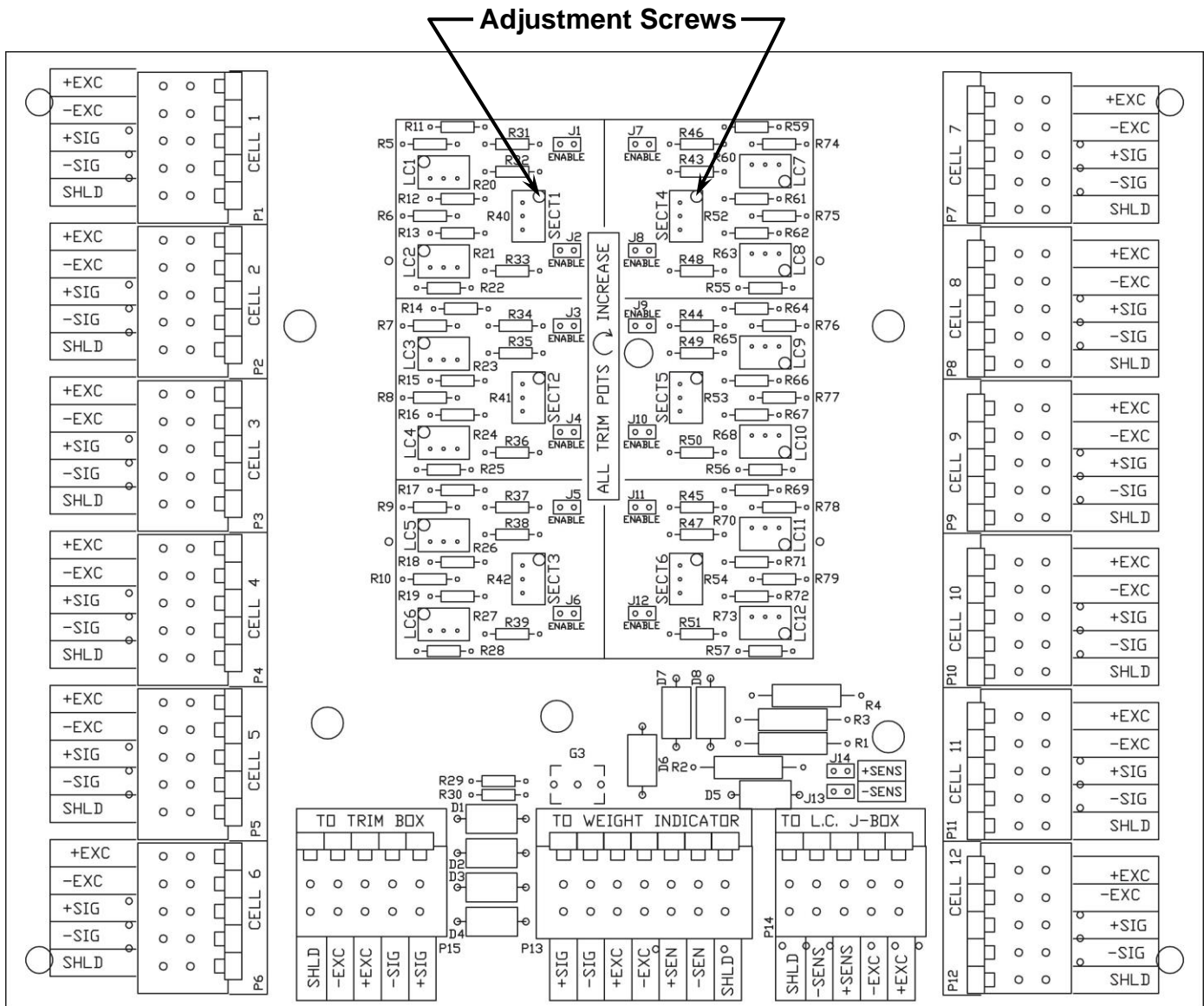

Figure No. 10 – Section Sealing Pots

SECTION-SEALING USING A TEST TRUCK

1. Drive the loaded test truck across the scale and record the weight obtained with the load centered over each section.
2. The section, which has the smallest displayed weight, will be the reference section and all other sections will be adjusted downscale to six (6) divisions below the reference section displayed weight.
3. Zero the display of the weight indicator before driving the test truck onto the scale.
4. Center the weight of the test truck over the section being sealed.
5. Adjust the appropriate section-sealing pot to make the displayed weight agree with the weight obtained in Step 2.
6. Drive the test truck off the scale.
7. Repeat Steps 3, 4, 5 and 6 until the displayed weight of the section being sealed agrees with the reference weight. When the weights agree without any more adjustment, move to the next section and repeat the procedure.

When the section sealing is completed, the weight indicator must be recalibrated using a division size of 20 lb. This time turn on the auto-zero function. Refer to the Weight Indicator Installation and Technical Manual.

SECTION SEALING WITH TEST WEIGHTS

1. When testing the scale with test weights on each section, place the available test weights on section 1 of the scale. Record the displayed weight. Move the test weights to each of the other sections in turn. If any section has a displayed weight that is more than 20 pounds different from the weight of section 1, the section should be adjusted.

Table C – Section-Seal Adjustment Chart

Section	CW	CCW	Weight Reading	
			Before Adj.	After Adj.
1				
2				
3				
4				
5				
6				

2. The adjustment pots (See Figure No. 9) are labeled by section numbers and identify the section with which each is associated. A clockwise (CW) rotation of the adjustment screw will raise the displayed weight reading. A counter-clockwise (CCW) adjustment will decrease the displayed weight reading.

SECTION SEALING WITH TEST WEIGHTS, CONT.

3. It is strongly suggested that a small notebook be used to record each action taken in section sealing the scale. The pot that was adjusted, the number of turns and the direction turned (CW or CCW) should be recorded for each adjustment as it is made.

It should be remembered that not always does the display change as you adjust the section-seal pot.

As you turn it, you are making a change, but you cannot see the change. Instead of changing the displayed weight, the adjustment is actually shifting zero. This has the same effect as changing the displayed weight, but there is no indication of the magnitude of the change made.

When this occurs, it is necessary to unload the scale, re-zero and resume the procedure.

This does not change the relationship of the other sections to each other.

It is at a time like this that the notebook record is invaluable.

When the section sealing is completed, the weight indicator instrument must be recalibrated using a division size of 20 lb. This time turn on the auto-zero function. Refer to the Weight Indicator Installation and Technical Manual for instructions.

SECTION IV

TROUBLESHOOTING

1. Open all junction boxes and check for moisture, loose connections or damaged wiring. Check all cables for damage.
2. Use a jack to lift the weighbridge off each load cell.



CAUTION! Be sure any restraint system is loosened before jacking up scale.

3. Disconnect the signal leads of the cell and check its output voltage using a meter with a 10-microvolt minimum resolution. Any load cell with a no load output of more than 2 or 3 millivolts should be considered suspect. Record the no load outputs from each cell in Table D, Column 1.
4. While the weighbridge is off the load cell, physically check the load buttons, load cup, upper load bearing plate and grout plate for any damage. Check to ensure that the grout is still in good condition.
5. With the weighbridge *only* on the load cells and the signal wires still disconnected, record each load cell output voltage in Table D, Column 2. If there is a difference of more than one millivolt between two lateral cells, install one or more shims between the upper loading bearing plate and weighbridge until the two cells' output are within one millivolt. Keep in mind that the four end cells should be approximately the same and the center cells should be approximately the same. After all shimming is complete, record all outputs for possible future use, in Table D, Column 3.

TROUBLESHOOTING, CONT.

Table D – Load Cell Output Voltage Chart

Cell No.	No Load		Dead Load	
	Col. 1 mV Output	Col. 2 mV Output	Col. 3 mV Output	Col. 4 mV Output
1				
2				
3				
4				
5				
6				
7				
8				
9				
10				
11				
12				

6. Check to ensure that the end lateral stabilizers are level, square and tight. If there is any kind of gap filler on the ends of the scale, ensure that it is not causing any force on the scale.
7. Check and adjust section and calibrate scale.
8. If the problem should occur again, check the load cell outputs against the values recorded in Step 5. Any appreciable change could indicate a possible defective load cell. If the load cells check OK, install a different indicator to eliminate the possibility of an indicator problem.

STATEMENT OF LIMITED WARRANTY

WARRANTY TERMS

Cardinal Scale Manufacturing Company warrants the equipment we manufacture against defects in material and workmanship. The length and terms and conditions of these warranties vary with the type of product and are summarized below:

PRODUCT TYPE	TERM	MATERIAL AND WORKMANSHIP	LIGHTNING DAMAGE See note 9	WATER DAMAGE See note 7	CORROSION See note 4	ON-SITE LABOR	LIMITATIONS AND REQUIREMENTS
WEIGHT INDICATORS	90 DAY REPLACEMENT ----- 1 YEAR PARTS	YES	YES	YES	YES	NO	1, 2, 3, 5, 6 A, B, C, D
LOAD CELLS (Excluding Hydraulic)	1 YEAR	YES	YES	YES	YES	NO	1, 2, 3, 5, 6 A, B, C, D
HYDRAULIC LOAD CELLS (When purchased with Guardian Vehicle Scale)	LIFE	YES	YES	YES	YES	90 DAYS	1, 5, 6, 8 A, B, C, D
HYDRAULIC LOAD CELLS (When purchased separately)	10 YEARS	YES	YES	YES	YES	NO	1, 5, 6, 8, 9 A, B, C, D
VEHICLE SCALE (Deck and Below Excl. PSC Series)	5 YEARS	YES	YES	YES	YES	90 DAYS	1, 2, 3, 5, 6 A, B, C, D, E
PSC and LSC SCALE STRUCTURES (Deck and Below)	3 YEARS	YES	YES	YES	YES	90 DAYS	1, 2, 3, 5, 6, 11 A, B, C, D
GUARDIAN FLOOR SCALES	10 YEARS	YES	YES	YES	YES	NO	1, 2, 3, 5, 6, 9, 10 A, B, C, D
ALL OTHER CARDINAL PRODUCTS	1 YEAR	YES	YES	YES	YES	NO	1, 2, 5, 6 A, B, C, D, E
REPLACEMENT PARTS	90 DAYS	YES	YES	YES	YES	NO	1, 2, 4, 5, 6 A, B, C, D
IN-MOTION VEHICLE SCALES	1 YEAR	YES	YES	YES	YES	90 DAYS	1, 2, 5, 6 A, B, C, D
SOFTWARE	90 DAYS	YES	N/A	N/A	N/A	NO	1, 6 B, C, D



Ph. (800) 441-4237
 E-mail: cardinal@cardet.com
 203 E. Daugherty
 Webb City, MO 64870

06/13
 Printed in USA
 315-WARRANTY-CAR-K

APPLICABLE LIMITATIONS AND REQUIREMENTS

1. This warranty applies only to the original purchaser. The warranty does not apply to equipment that has been tampered with, defaced, damaged, or had repairs or modifications not authorized by Cardinal or has had the serial number altered, defaced or removed.
2. This warranty is not applicable to equipment that has not been grounded in accordance with Cardinal's recommendations.
3. This equipment must be installed and continuously maintained by an authorized Cardinal dealer.
4. Applies only to components constructed from stainless steel.
5. This warranty does not apply to equipment damaged in transit. Claims for such damage must be made with the responsible freight carrier in accordance with freight carrier regulations.
6. Warranty term begins with date of shipment from Cardinal.
7. Only if device is rated NEMA 4 or better or IP equivalent.
8. Lifetime warranty applies to damages resulting from water, lightning, and voltage transients and applies only to the hydraulic load cell structure itself (does not include pressure transducers, rubber seals, o-rings, and associated wiring).
9. 10 Year prorated warranty on hydraulic load cells.
10. 1 Year warranty for scale structure.
11. PSC models' warranty coverage applies only to agricultural installations on farms up to 3,000 acres (LSC models not limited in this manner).
12. Load cell kits MUST be installed in accordance with Cardinal Scale instructions. Failure to follow these instructions will void the warranty.

EXCLUSIONS

- A.) This warranty does not include replacement of consumable or expendable parts. The warranty does not apply to any item that has been damaged due to unusual wear, abuse, improper line voltage, overloading, theft, fire, water, prolonged storage or exposure while in purchaser's possession or acts of God unless otherwise stated herein.
- B.) This warranty does not apply to peripheral equipment not manufactured by Cardinal. This equipment will normally be covered by the equipment manufacturer's warranty.
- C.) This warranty sets forth the extent of our liability for breach of any warranty or deficiency in connection with the sale or use of our product. Cardinal will not be liable for consequential damages of any nature, including but not limited to loss of profit, delays or expenses, whether based on tort or contract. Cardinal reserves the right to incorporate improvements in material and design without notice and is not obligated to incorporate said improvements in equipment previously manufactured.
- D.) This warranty is in lieu of all other warranties expressed or implied including any warranty that extends beyond the description of the product including any warranty of merchantability or fitness for a particular purpose. This warranty covers only those Cardinal products installed in the forty-eight contiguous United States and Canada.
- E.) This warranty does not cover paint coatings due to the variety of environmental conditions.
- F.) Do not cut load cell cables on load cells returned for credit or warranty replacement. Cutting the cable will void the warranty.
- G.) Software is warranted only for performance of the functions listed in the software manual and/or the Cardinal proposal.
- H.) The software warranty does not cover hardware. Warranties on hardware are provided from the hardware vendor only.
- I.) The software warranty does not cover interfacing issues to non-Cardinal supplied hardware.
- J.) The software warranty does not include automatic software upgrades unless purchased separately.



Ph. (800) 441-4237
E-mail: cardinal@cardet.com
203 E. Daugherty
Webb City, MO 64870

06/13
Printed in USA
315-WARRANTY-CAR-K

