



# **PZ30W / PZ60W**

## **Wireless Pizza Scale**

### **Owner's Manual**

## FCC Compliance Statement

This equipment has been tested and found to comply with the limits for a Class B digital device, pursuant to Part 15 of the FCC Rules. These limits are designed to provide reasonable protection against harmful interference in a residential installation. This equipment generates, uses and can radiate radio frequency energy and, if not installed and used in accordance with the instructions, may cause harmful interference to radio communications. However, there is no guarantee that interference will not occur in a particular installation. If this equipment does cause harmful interference to radio or television reception, which can be determined by turning the equipment off and on, the user is encouraged to try to correct the interference by one or more of the following measures:

- Reorient or relocate the receiving antenna.
- Increase the separation between the equipment and receiver.

Modifications not authorized by the manufacturer may void user's authority to operate this device.

FCC ID: YKFRF2500

## Transmission Collision

Signals from other household devices, such as doorbells, home security systems and entry controls, may interfere. This is normal and does not affect the general performance of this product. The transmission will resume once the interference recedes.

## Proper Disposal

When this device reaches the end of its useful life, it must be properly disposed of. It must not be disposed of as unsorted municipal waste. Within the European Union, this device should be returned to the distributor from where it was purchased for proper disposal. This is in accordance with EU Directive 2002/96/EC. Within North America, the device should be disposed of in accordance with the local laws regarding the disposal of waste electrical and electronic equipment.

It is everyone's responsibility to help maintain the environment and to reduce the effects of hazardous substances contained in electrical and electronic equipment on human health. Please do your part by making certain that the device is properly disposed of. The symbol shown to the right indicates that this device must not be disposed of in unsorted municipal waste programs.



## Copyright

All rights reserved. Reproduction or use, without expressed written permission, of editorial or pictorial content, in any manner, is prohibited. No patent liability is assumed with respect to the use of the information contained herein.

## Disclaimer

While every precaution has been taken in the preparation of this manual, the Seller assumes no responsibility for errors or omissions. Neither is any liability assumed for damages resulting from use of the information contained herein. All instructions and diagrams have been checked for accuracy and ease of application; however, success and safety in working with tools depend to a great extent upon the individual's accuracy, skill and caution. For this reason, the Seller is not able to guarantee the result of any procedure contained herein. Nor can they assume responsibility for any damage to property or injury to persons occasioned from the procedures. Persons engaging the procedures do so entirely at their own risk.



# TABLE OF CONTENTS

INTRODUCTION.....	1
SPECIFICATIONS .....	1
DISPLAY .....	2
KEYS AND ICON DESCRIPTION .....	2
PREPARING SCALE FOR WEIGHING .....	3
CHANGING THE WIRELESS DISPLAY'S CHANNEL .....	4
SELECTING THE SCALE BASE'S CHANNEL .....	5
DISPLAY MOUNTING .....	6
AC POWER ADAPTER .....	8
OPERATION .....	9
FUNCTION SETTINGS .....	10
ERROR MESSAGES .....	12
CARE AND CLEANING .....	12



## Manufacturer's Declaration of Conformity

This product has been manufactured in accordance with the harmonized European standards, following the provisions of the below stated directives:  
Electro Magnetic Compatibility Directive 2014/30/EU  
Low Voltage Directive 2014/35/EU

<p><b>Serial Number</b> _____</p> <p><b>Date of Purchase</b> _____</p> <p><b>Purchased From</b> _____</p> <p>_____</p> <p>_____</p> <p>_____</p> <p>RETAIN THIS INFORMATION FOR FUTURE USE</p>	<p><b>PRECAUTIONS</b></p> <p>Before using this scale, read this manual and pay special attention to all "NOTIFICATION" symbols:</p> <p> IMPORTANT  ELECTRICAL WARNING</p>
--	---



## INTRODUCTION

Thank you for purchasing our Detecto PZ30W / PZ60W Wireless Pizza Scale. Your scale has been designed for simple, straightforward use and to assure dependable accuracy for years to come.

Please read this manual thoroughly before using your scale and keep it handy for future reference. It contains important instructions for installation and proper operation of your scale.









## SPECIFICATIONS

Model / Capacity	PZ30W	0-10 lb x 0.05 oz / 10-30 lb x 0.1 oz 0-5 kg x 0.002 kg / 5-15 kg x 0.005 kg 30 lb x 1/8 oz
Model / Capacity	PZ60W	60 lb x 0.2 oz 60 lb x 1/4 oz 30 kg x 0.01 kg
Weight Unit	lb: oz (decimals) lb: oz (fractions) kg	
Weight Display	1" (25mm) LCD readout	
Dimensions Display Scale Base	6.63" x 3" x 1.75" (168mm x 76mm x 45mm) 14" x 14" x 1.6" (356mm x 356mm x 41mm)	
Keys	ON/OFF, HOLD, TARE, UNITS, CHANNEL	
Power Requirements	10-AA batteries, (6) for scale base, (4) for Display (not included) or (2) 15V AC Adapters (included), one each for scale base and display	
Operation Temperature	32 to 104°F (0 to 40°C)	
Certifications	NOT LEGAL FOR TRADE	

# DISPLAY

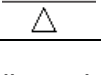
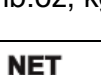
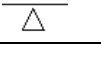

## KEYS AND ICON DESCRIPTION

	Press to turn the scale ON or OFF.
	Press to Tare (zero) the weight of any container while weighing.
	Press once to activate the HOLD function. Press again to cancel the HOLD function and return to normal weighing mode.
	Press to switch between lb: oz and kg units of measurement.
	Touch Free Tare sensor – Pass hand in front of sensor.
	Indicates scale is at center of zero.
	Icon flashes when scale is ready for a weighing.
	Stability display: If the display shows 'o', the weight is stable on the scale. If the display shows 'o-', the weight is unstable.
	Indicates the weight display HOLD function is activated.
	Indicates the weighing unit.
	Activated with the Tare function. Indicates the displayed weight is the net weight on the scale.
	On (-) /Off (o) switch for scale base.

# PREPARING SCALE FOR WEIGHING



## Before Weighing

1. Place scale on a stable, vibration-free level surface away from direct sunlight and any rapidly moving air source (heating/cooling vents, fans, etc.). This will prevent sudden temperature changes and air currents that may result in unstable weight readings.
2. Make sure that the distance between the scale base and the wireless display is within 30 feet (10 meters).
3. Select the scale's channel to match the wireless display. (The scale's channel indicator is located on the scale's base; please remove the rubber stopper to access the channel indicator). For example: If the wireless display is using Channel-1, select Channel-1 for the scale. (Please see Page 5 for instructions for selecting scale base channels).

**NOTE:** If the scale's channel is not same as the wireless display, *88888* will appear on the display. Set the scale and wireless display to the same channel.

## Weighing

1. Turn on the scale base by pressing the power switch located on the underside of the scale base.
2. Press the ON/OFF key on the display to turn on the display.
3. *88888* will appear on the display, then *0* and  will flash. The scale is ready for weighing.

**NOTE:** If the *88888* display and *0* does not show and the  flash, press the  key to change the wireless display's channel to match the scale's channel.

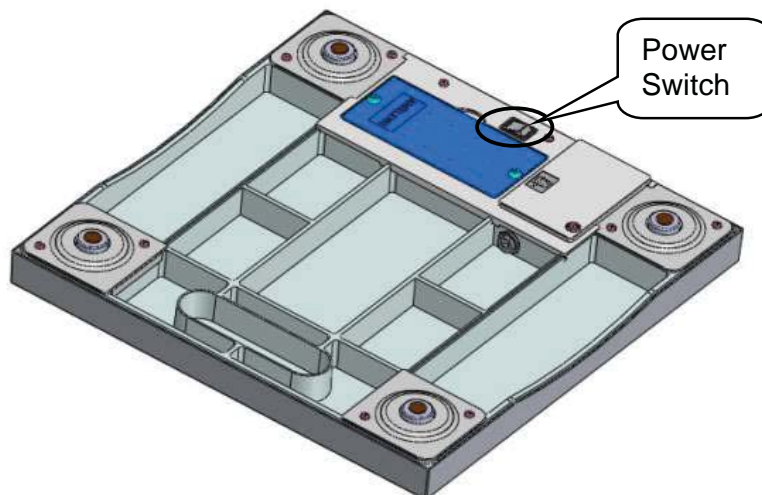

For example: if the scale's channel is set to Channel-1, please select Channel-1 for the wireless display also.



# CHANGING THE WIRELESS DISPLAY'S CHANNEL



Press the  key to select the wireless display channel. Channel numbers (1, 2 and 3) are shown on the left-hand side of the display. When a channel is selected, a triangle icon points to the selected channel. For example: If Channel-1 is selected, the triangle icon points to '1'.

<p>Channel 1</p>	
<p>Channel 2</p>	
<p>Channel 3</p>	



## SELECTING THE SCALE BASE'S CHANNEL

To select the scale base's channel, first turn off the scale base and wireless display units. Then use the dip switch, which is located on the bottom of the scale base under the rubber stopper. The dip switch has four switches marked (1, 2, 3, and 4). Switch-4 is not active; only 3 channels are available for use. To select a channel, move the switch toward the 'ON' mark (see illustration shown below).

For example: To select Channel-1 for the scale, move Switch-1 towards the 'ON' mark. After selecting the channel, turn on the scale base first, then the wireless display.

The dip switch is on the bottom of the scale base under the rubber stopper.

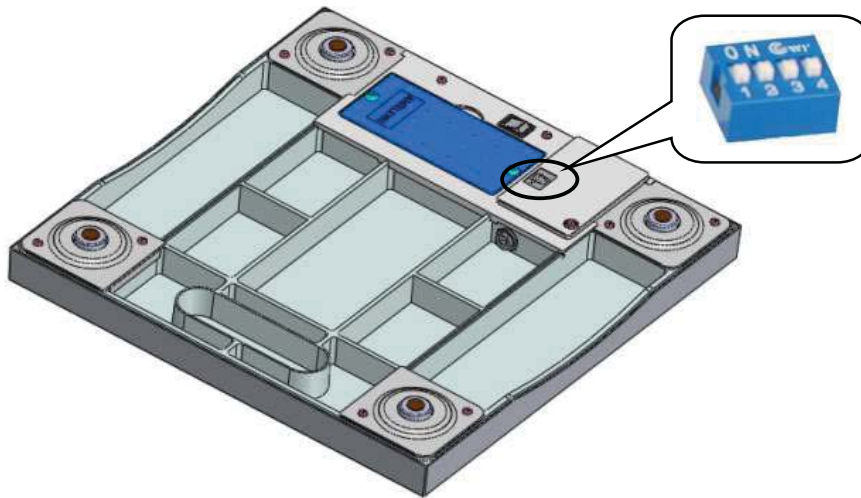

Channel 1	
Channel 2	
Channel 3	

# DISPLAY MOUNTING

## Desk or Table Mounting

The location chosen should be a stable, level surface (either a desk or solid table), free of temperature extremes and water. The display should be where it can be easily viewed, not subject to direct sunlight and where it is within easy reach of the operator. Note that the angle of the display can be adjusted for easy viewing.

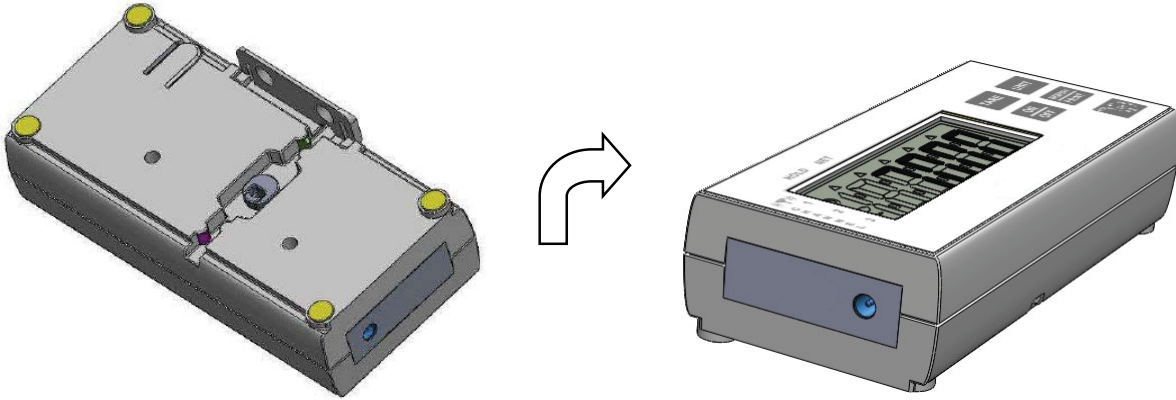

## Wall Mounting

The wireless display may be mounted on a wall using the included mounting hardware. Choose the location to mount the display on the wall. The location should be free of temperature extremes and water. It should be where the display can be easily viewed, not subject to direct sunlight and within easy reach of the operator. Make certain the structure of the wall will support the display.

1. Drill two (2) holes in the wall 1.25“(32mm) apart for the mounting wall anchors.

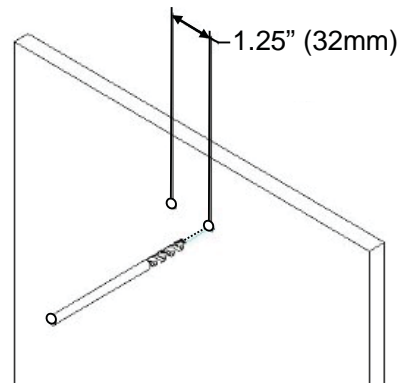

2. Insert the wall anchors in the wall until they are flush with the wall.

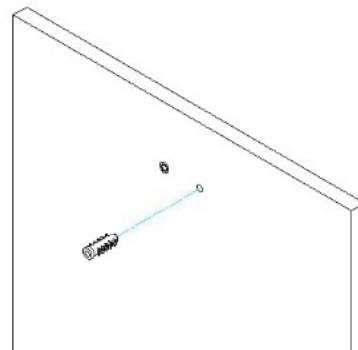

- Place the display against the wall and insert the two (2) screws through the holes in the display bracket and into the wall anchors.

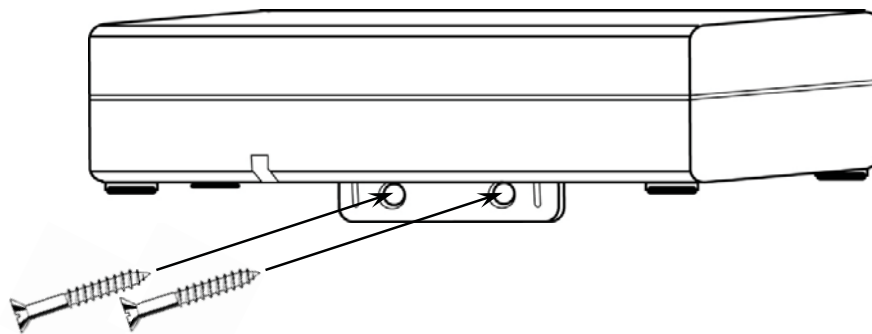

- Tighten the screws to secure the display bracket to the wall.

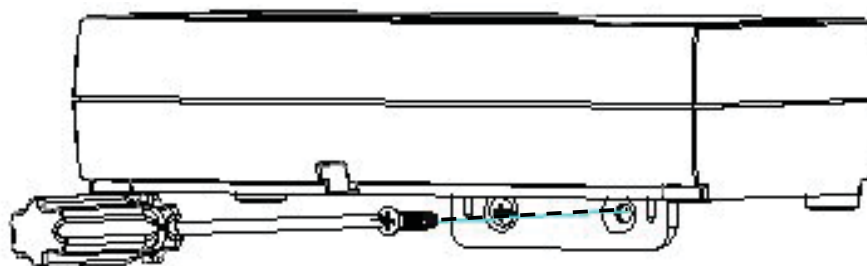

- Flip the display down as shown to use.

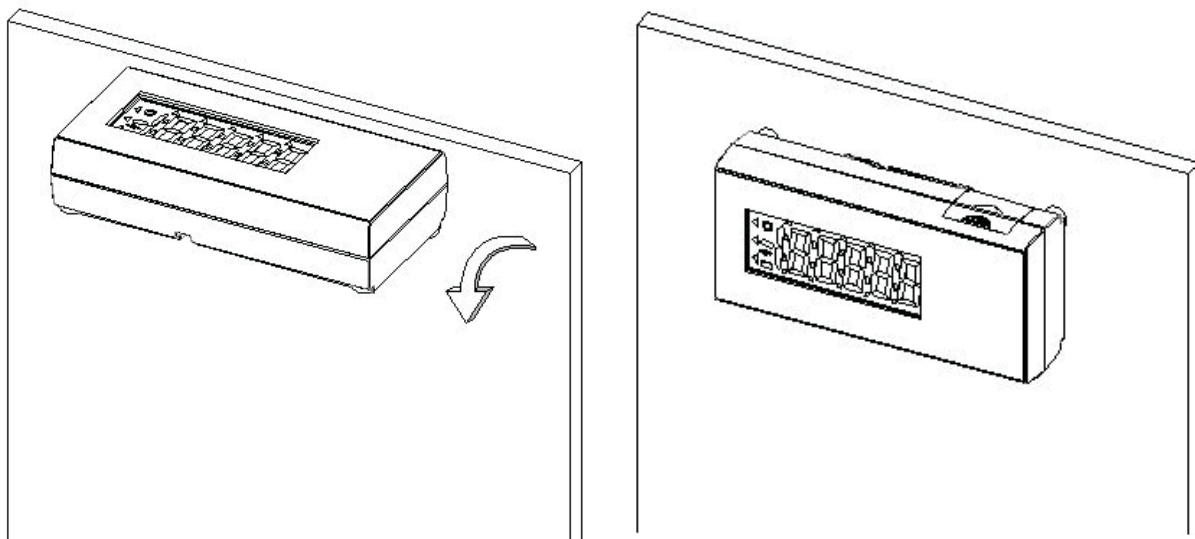

## AC POWER ADAPTER



If  is shown on the display, please use the included adapters or replace the batteries. Insert an adapter into the bottom of the wireless display and the scale base.

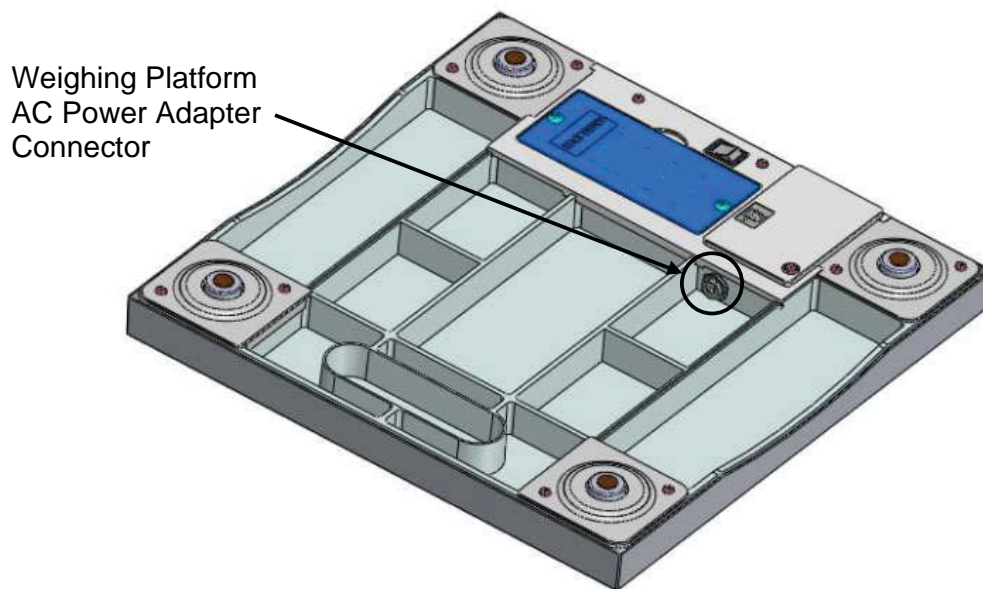
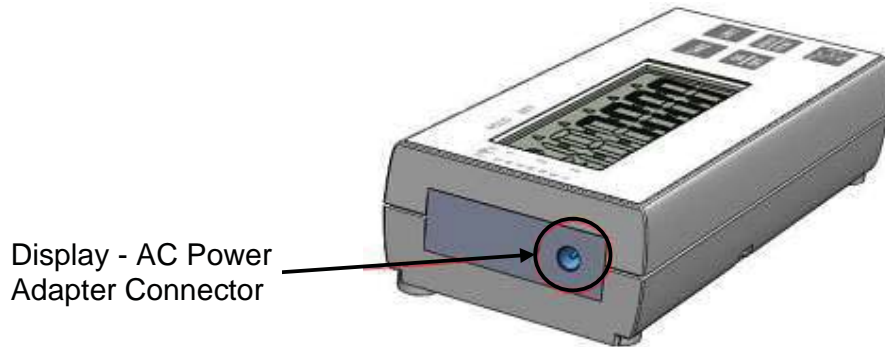

The scale's weighing platform and wireless display require separate electric power. Before using the scale, please make sure that both the scale base and wireless display have batteries correctly installed or both adapters correctly plugged in.

The scale base uses (6) AA batteries and the wireless display uses (4) AA batteries (*batteries not included*), or both units use a 15V AC adapter (*2 adapters included*).

# OPERATION

## Push Button Tare Function

The Tare Function allows the user to zero the scale to cancel out the weight of a container, thus giving the Net weight of the item being weighed.

- Press the ON/OFF key to turn on the scale.
- Place the container on the scale platform.
- Press the **TARE** key after the weight stabilizes and stable sign displays.
- The display will reset to 0.
- Place the item to be weighed on the platform (without removing the 'tared' container).
- Scale will display NET weight of item being weighed.

## Touch Free Tare Function

This scale is equipped with 'photo eye' sensor for a Touch Free Tare function. Simply pass your hand over the sensor and the scale will tare the weight.

- Place the container to be tared on the scale platform.



- Pass your hand over the sensor on the display.
- The display will reset to 0.
- Place the item to be weighed on the scale platform.

To reset the **TARE** to zero, remove all items and the tared container from the platform and then press the **TARE** key, or pass your hand over the sensor.

## Hold Weight Function

The HOLD function may be used to lock the weight on the display, even after the load is removed from the platform. To use the HOLD function, press the **HOLD** key. A small triangle will appear flashing in the upper left corner of the display below to the word HOLD indicating the HOLD function is active. This triangle and the HOLD function will remain active until the **HOLD** key is pressed again canceling the HOLD function and turning off the triangle on the display.

**NOTE:** When the scale is turned off, the HOLD function is cancelled. When the scale is turned on again, it will be in the normal operating mode.

- Press the **HOLD** key.
- Place a load on the platform. When the weight is locked in, the triangle will stop flashing. When the load is removed from the platform, the display will continue to show the weight.
- Press the **HOLD** key again to revert to the normal operating mode.
- You can also press the **TARE** key or use the Touch Free Tare sensor to revert to normal operating mode.

## FUNCTION SETTINGS

**NOTE:** If Touch Free Tare is enabled it works as the **TARE** key during setup.

### To enter Setup:

1. With the display turned ON, press and hold the **TARE** key for approximately 3 seconds.
2. When *SETUP* is displayed, release the **TARE** key.
3. The display will show the software revision level, then change to *Unit*.

### *Unit* (WEIGHING UNITS)

Kilogram weighing units (0-5 kg x 0.002 kg / 5-15 kg x 0.005 kg)

1. With the display showing *Unit*, press the **TARE** key.  
The display will change to show “kg” and display the kg status.
2. Press the **LOCK/UNLOCK** key to toggle between;  
Enable (display will change to *On*) or  
Disable (display will change to *OFF*).
3. Press the **TARE** key to advance display to show “oz” and display the oz status.

Fractional ounces weighing units (30 lb x 1/8 oz)

1. Press the **LOCK/UNLOCK** key to toggle between;  
Enable (display will change to *On*) or  
Disable (display will change to *OFF*).
2. Press the **TARE** key to advance to change to show “lb oz” and display the lb oz status.

Pound and ounces weighing units (0-10 x 0.05 oz / 10-30 lb x 0.1 oz)

1. Press the **LOCK/UNLOCK** key to toggle between;  
Enable (display will change to *On*) or  
Disable (display will change to *OFF*).
2. Press the **TARE** key. The display will change to *Unit*.
3. Press the **LOCK/UNLOCK** key advance to *ROFF* (AUTOMATIC SHUTOFF).

## FUNCTION SETTINGS, CONT.

### *ROFF* (AUTOMATIC SHUTOFF)

1. Press the **TARE** key to begin selection of the automatic shut-off time (in seconds). The display will change to show *120 S*.
2. Press the **TARE** key to toggle through the selections;  
*120 S, 180 S, 240 S, 300 S, or OFF.*
3. When the desired time is displayed, press the **LOCK/UNLOCK** key. The display will change to show *ROFF*.
4. Press the **LOCK/UNLOCK** key advance to *FILT* (FILTER SETTING).

### *FILT* (FILTER SETTING)

1. Press the **TARE** key to begin selection of the filter setting.
2. The display will change to show *F2*.
3. Press the **TARE** key to toggle through the selections;  
*F1* (low)  
*F2* (normal, default)  
*F3* (high)  
*F4* (highest, the weight update is slower)
4. When the desired filter setting is displayed, press the **LOCK/UNLOCK** key. The display will change to show *FILT*.
5. Press the **LOCK/UNLOCK** key advance to *TLR* (TOUCHLESS TARE)

### *TLR* (TOUCHLESS TARE)

1. Press **TARE** to display status.
2. Press the **LOCK/UNLOCK** key to toggle between;  
Enable (display will change to *ON*) or  
Disable (display will change to *OFF*).
3. Press the **TARE** key. The display will change to *TLR*.
4. Press the **LOCK/UNLOCK** key to advance to *End*.
5. Press the **LOCK/UNLOCK** key to return to beginning of Setup.
6. Press **TARE** key to save settings and exit setup. Scale returns to normal weighing operation.

## ERROR MESSAGES

Message	Description
<i>Lo</i>	Low battery indicator for wireless display: This warning indicates the batteries for the wireless display are low. Please replace all the batteries or use the AC adapter for operation.
<i>Lod</i>	Low battery indicator for scale base: This warning indicates the batteries for the scale base are low. Please replace all batteries or use the AC adapter for operation.
<i>ErrE</i>	EEPROM error for wireless display: The programming for the wireless display has an error. Please contact technical support or your scale service provider.
<i>ErrEd</i>	EEPROM error for scale base: The programming for the scale base has an error. Please contact technical support or your scale service provider.
<i>Err</i>	Overload or counting error (too high): The weight or count capacity is over the limit. Please reduce the weight/count and try again.
<i>ErrL</i>	Overload or counting error (too low): The weight or count capacity is under the limit. Please increase the weight/count capacity and try again.

## CARE AND CLEANING

The heart of the Detecto PZ30W / PZ60W Wireless Pizza Scale is four precision load cells located in each corner of the scale base. They will provide accurate operation indefinitely if protected against overload of scale capacity, dropping items on scale, or other extreme shock.

- **DO NOT** submerge the scale or display in water, pour or spray water directly on them.
- **DO NOT** use acetone, thinner or other volatile solvents for cleaning.
- **DO NOT** expose scale to direct sunlight or temperature extremes.
- **DO NOT** place scale in front of heating/cooling vents.
- **DO** clean the scale and display with a damp soft cloth and mild non-abrasive detergent.
- **DO** remove power before cleaning with a damp cloth.
- **DO** provide clean AC power and adequate protection against lightning damage.
- **DO** keep the surroundings clear to provide clean and adequate air circulation.



# STATEMENT OF LIMITED WARRANTY

DETECTO warrants its equipment to be free from defects in material and workmanship as follows: DETECTO warrants to the original purchaser only that it will repair or replace any part of equipment which is defective in material or workmanship for a period of **two (2) years from date of shipment**. Detecto shall be the sole judge of what constitutes a defect.

During the **first ninety (90) days** DETECTO may choose to replace the product at no charge to the buyer upon inspection of the returned item.

**After the first ninety (90) days**, upon inspection of the returned item, DETECTO will repair or replace it with a remanufactured product. The customer is responsible for paying for the freight both ways.

This warranty does not apply to peripheral equipment not manufactured by DETECTO; this equipment will be covered by certain manufacturer's warranty only.

This warranty does not include replacement of expendable or consumable parts. This does not apply to any item which has deteriorated or damaged due to wear, accident, misuse, abuse, improper line voltage, overloading, theft, lightning, fire, water or acts of God, or due to extended storage or exposure while in purchaser's possession. This warranty does not apply to maintenance service. Purchased parts will have a ninety (90) day repair or replacement warranty only.

DETECTO may require the product to be returned to the factory; item(s) must be properly packed and shipping charges prepaid. A return authorization number must be obtained for all returns and marked on the outside of all returned packages. DETECTO accepts no responsibility for items lost or damaged in transit.

## Conditions Which Void Limited Warranty

This warranty shall not apply to equipment which:

- A.) Has been tampered with, defaced, mishandled or has had repairs and modifications not authorized by DETECTO.
- B.) Has had serial number altered, defaced, or removed.
- C.) Has not been properly grounded according to Detecto's recommended procedure.

## Freight Carrier Damage

Claims for equipment damaged in transit must be referred to the freight carrier in accordance with freight carrier regulations.

This warranty sets forth the extent of our liability for breach of any warranty or deficiency in connection with the sale or use of the product. DETECTO will not be liable for consequential damages of any nature, including but not limited to, loss of profit, delays or expenses, whether based on tort or contract. Detecto reserves the right to incorporate improvements in material and design without notice and is not obligated to incorporate improvements in equipment previously manufactured.

The foregoing is in lieu of all other warranties, express or implied including any warranty that extends beyond the description of the product including any warranty of merchantability or fitness for a particular purpose. This warranty covers only those DETECTO products installed in the forty-eight (48) contiguous continental United States.



Ph. (800) 641-2008  
E-mail: [detecto@cardet.com](mailto:detecto@cardet.com)  
102 E. Daugherty  
Webb City, MO 64870

04/22/2024  
Printed in USA  
D268-WARRANTY-DET-B



*DETECTO*

*102 E. Daugherty, Webb City, MO 64870 USA*

*Ph: 417-673-4631 or 1-800-641-2008*

*Fax: 417-673-2153*

*[www.Detecto.com](http://www.Detecto.com)*

*Technical Support: 1-866-254-8261*

*E-mail: [tech@cardet.com](mailto:tech@cardet.com)*