

DETECTO®



6745 Digital Baby Scale Owner's Manual

INTRODUCTION

Thank you for purchasing our DETECTO 6745 Digital Baby Scale. The 6745 is a 30-pound (15 kilograms) capacity, battery-operated baby scale housed in a painted steel enclosure. The scale is equipped with a removable baby tray and a multi-color touchscreen LCD display. The Model 6745 has many distinctive features that make it both easy to use and maintain and includes built-in Wi-Fi and Bluetooth 5.0 for EMR/EHR.

This manual is provided to guide you through the setup and operation of your scale. Please read it thoroughly before attempting to set up or operate your scale and keep it available for future reference.

This manual is to be used for the following models of the 6745 Digital Baby Scale:

6745	30-pound (15 kilograms) capacity with US (Type B) power supply plug
6745KG	15 kilograms capacity with US (Type B) power supply plug
6745EU	15 kilograms capacity with EU (Type C) power supply plug
6745UK	15 kilograms capacity with UK (Type G) power supply plug

COPYRIGHT



All rights reserved. Reproduction or use, without express written permission, of editorial or pictorial content, in any manner, is prohibited. No patent liability is assumed with respect to the use of the information contained herein.

DISCLAIMER

While every precaution has been taken in the preparation of this manual, the Seller assumes no responsibility for errors or omissions. Neither is any liability assumed for damages resulting from the use of the information contained herein. All instructions and diagrams have been checked for accuracy and ease of application; however, success and safety in working with tools depend to a great extent upon individual accuracy, skill, and caution. For this reason, the Seller is not able to guarantee the result of any procedure contained herein. Nor can they assume responsibility for any damage to property or injury to persons occasioned from the procedures. Persons engaging in the procedures do so entirely at their own risk.

Serial Number _____
Date of Purchase _____
Purchased Form _____

RETAIN THIS INFORMATION FOR FUTURE USE

PRECAUTIONS	
Before using this instrument, read this manual and pay special attention to all "NOTIFICATION" symbols:	
	IMPORTANT
	ELECTRICAL WARNING

PROPER DISPOSAL

When this device reaches the end of its useful life, it must be properly disposed of. It must not be disposed of as unsorted municipal waste. Within the European Union, this device should be returned to the distributor from where it was purchased for proper disposal. This is in accordance with EU Directive 2002/96/EC. Within North America, the device should be disposed of in accordance with the local laws regarding the disposal of waste electrical and electronic equipment.

It is everyone's responsibility to help maintain the environment and to reduce the effects of hazardous substances contained in electrical and electronic equipment on human health. Please do your part by making certain that this device is properly disposed of. The symbol shown to the right indicates that this device must not be disposed of in unsorted municipal waste programs.



CAUTION



CAUTION: RISK OF EXPLOSION IF BATTERY IS REPLACED BY AN INCORRECT TYPE. DISPOSE OF USED BATTERIES ACCORDING TO THE INSTRUCTIONS.

ATTENTION: RISQUE D'EXPLOSION SI LA BATTERIES EST REMPLAC'E PAR UN TYPE INCORRECT. REJETEZ LES BATTERIES UTILISE'ES SELON LES INSTRUCTIONS.

Contains FCC ID: 2ADHKWINC3400

1. This device complies with Part 15 of the FCC rules. Operation is subject to the following two conditions:
 - (1) This device may not cause harmful interference.
 - (2) This device must accept any interference received, including interference that may cause undesired operation.
2. Changes or modifications not expressly approved by the party responsible for compliance could void the user's authority to operate the equipment.

FCC RADIATION EXPOSURE STATEMENT

This equipment complies with FCC RF radiation exposure limits set forth for an uncontrolled environment. This transmitter must not be co-located or operated in conjunction with any other antenna or transmitter.

TABLE OF CONTENTS

SPECIFICATIONS	Page 1
Standard Features	Page 1
SITE PREPARATION REQUIREMENTS	Page 2
Environmental	Page 2
Electrical Power	Page 2
Electrical Noise Interference	Page 2
INSTALLATION	Page 3
Unpacking	Page 3
Shipping Screws	Page 3
Carrying Handle Installation	Page 3
Level Adjustment	Page 4
Baby Tray Installation	Page 4
Placing the Scale	Page 4
AC Power Adapter	Page 4
Battery Operation	Page 5
Battery Status	Page 5
Battery Installation or Replacement	Page 6
KEYPAD FUNCTIONS	Page 7
ANNUNCIATORS	Page 9
OPERATION	Page 10
Basic Weighing Operation	Page 10
Basic Weighing Operation with ID	Page 11
Breastmilk Intake Function	Page 12
Diaper Weight Function	Page 16
SCALE SETUP	Page 20
CALIBRATE SCALE	Page 33
To Enter Calibration	Page 33
To Perform Calibration	Page 35
Wi-Fi AND BLUETOOTH 5.0	Page 37
Wi-Fi Features	Page 37
Wi-Fi SETUP	Page 37
Enable and Configure Wi-Fi Networking	Page 37
Configure Wi-Fi Network Module	Page 41
Changing the Network Credentials	Page 43
Display Wi-Fi Network Settings	Page 43
Wi-Fi OPERATION	Page 44
Web Server	Page 44
TCP/IP Connection	Page 45
SMA Commands	Page 45

TABLE OF CONTENTS, CONT.

BLUETOOTH LOW ENERGY (BLE)	Page 46
Features Available with BLE	Page 46
Enable Bluetooth (BLE) Networking	Page 46
Bluetooth Pairing	Page 49
INTERFACING TO BLE	Page 50
Standard Services per Bluetooth SIG	Page 50
Device Information Service (0x180A)	Page 50
Battery Service (0x180F)	Page 50
Weight Scale Service (0x181D)	Page 50
BLUETOOTH INTERFACE STANDARD PROTOCOLS	Page 51
Bluetooth Characteristic – Weight_Measurement: 0x2A9D	Page 51
Weight_Measurement: 0x2A9D	Page 51
Custom Services	Page 52
DETECTO SMA Service (0x907a0000-8699-47dd-ab30-d7aad5f83e54)	Page 52
SMA Commands	Page 52
Wi-Fi AND BLUETOOTH SMA COMMANDS	Page 53
DISPLAY SCALE Wi-Fi AND BLUETOOTH SETTINGS	Page 55
ERROR AND OPERATION MESSAGES	Page 56
BEFORE YOU CALL SERVICE	Page 57
CARE AND CLEANING	Page 57
PRINTER OUTPUT	Page 58
PARTS IDENTIFICATION	Page 59
Final Assembly Parts List	Page 59
Final Assembly – Display (A to A) and Side View	Page 59
Final Assembly – Front and Bottom View	Page 60
Baby Tray Assembly Parts List	Page 60
Baby Tray Assembly	Page 61

SPECIFICATIONS



Capacity:	0 - 10 lb x 0.002 lb / 10 - 30 lb x 0.005 lb 0 - 10 lb x 0.02 oz / 10 - 30 lb x 0.05 oz 0 - 5 kg x 0.001 kg / 5 - 15 kg x 0.002 kg
Platform Size (Flat Portion):	22.5 in W x 9.1 in D (57.1 cm x 23.1 cm)
Overall Dimensions	
Width:	25.7 in / 65.3 cm
Depth:	15.1 in / 38.4 cm
Height:	7.5 in / 19.0 cm
Weight:	34.1 lb (15.5 kg)
Display Type:	3.2 in / 81.3 mm (diagonal) full-color TFT display 320 x 240 resolution
Touch Screen:	Resistive touch panel covering the display
Keys:	Mechanical switch type, Zero/Tare, Recall, Enter, Lock/Unlock, Menu, Reweigh, and Power
Power Requirements:	Included 100 to 240 VAC 50/60Hz 12 VDC 1.2A UL and CE Approved Medical Grade Power Supply. 6745/6745KG includes MV1PWR with a US (Type B) plug. 6745EU includes MV2PWR with an EU (Type C) plug. 6745UK includes MV1PWRUK with a UK (Type G) plug. Optional Six C-size Alkaline, Ni-Cad, or NiMH batteries (not included)
Operating Environment:	Operated Temperature Range: 50 to 104 °F (+10 to +40 °C) Humidity: 0 to 90% non-condensing
Communication Interfaces:	RS232, USB-B, Wi-Fi, and Bluetooth 5.0

Standard Features:

- 8-Digit Numeric Patient ID
- StableSENSE®¹ Adjustable Filtering
- Wi-Fi and Bluetooth 5.0
- Sturdy Steel Construction
- Breastmilk Intake Feature
- Diaper Weight Feature

¹ StableSENSE® is a digital filter utilizing a proprietary software algorithm that removes or greatly reduces changes in the weight display resulting from movement on the scale platform. When used with clinical scales, it will lessen the effects of the patient's movement or vibration on the scale.

SITE PREPARATION REQUIREMENTS

The DETECTO 6745 Digital Baby Scale is a precision weight indicating instrument. As with any precision instrument, it requires an acceptable environment to operate at peak performance and reliability. This section will assist you in obtaining such an environment.

Environmental

- For indoor use only.
- Suitable for dry environments only RH < 90% and non-condensing environments.
- NEVER allow the scale to get wet.
- The scale meets or exceeds all certification requirements within a temperature range of 50 to 104 °F (+10 to +40 °C).

The scale should be placed out of direct sunlight and to provide adequate air circulation, keep the area around the scale clear.

Do not place the scale directly in front of a heating or cooling vent. Such a location will subject it to sudden temperature changes, which may result in unstable weight readings.

When using the AC power adapter, ensure that the scale has good, clean AC power and is properly grounded. In areas subject to lightning strikes, additional protection to minimize lightning damage, such as surge suppressors, should be installed.

Electrical Power

The 6745 Digital Baby Scale has been designed to operate from a 100 to 240V AC 50/60Hz, 12V DC 1.2A UL and CE Approved Medical Grade Power Supply.

Model	Part Number	Description
6745	MV1PWR	Medical Grade Power Supply with US (Type B) plug
6745KG	MV1PWR	Medical Grade Power Supply with US (Type B) plug
6745EU	MV2PWR	Medical Grade Power Supply with EU (Type C) plug
6745UK	MV1PWRUK	Medical Grade Power Supply with UK (Type G) plug

- The socket outlet supplying power to the indicator should be on a separate circuit from the distribution panel and dedicated to the exclusive use of the indicator.
- The socket outlet shall be installed near the equipment and shall be easily accessible.

Electrical Noise Interference

To prevent electrical noise interference, make certain all air conditioning and heating equipment, lighting, or other equipment with heavily inductive loads, are on circuits separate from the system. These sources of disturbances can affect the operation of the scale. Steps must be taken to prevent possible adverse effects on the scale. For example, using simple line filters, isolation transformers, power regulators, or uninterruptible power supplies.

INSTALLATION

Unpacking

Begin the installation by removing your new DETECTO 6745 Digital Baby Scale from the shipping carton. Examine the scale and baby tray for any damage that may have taken place during shipment. If you find evidence of shipping damage, the shipping company should be contacted at once. It is a good idea to keep the scale shipping carton and packing material for later use should storage or transport of the scale become necessary.

Shipping Screws

The load cell in your DETECTO 6745 Digital Baby Scale is secured during shipping by two shipping screws, one on each side of the scale enclosure where the carrying handles will be installed. Remove these screws by unscrewing them from the sides of the scale enclosure. Refer to the images below.



Location of Shipping Screw

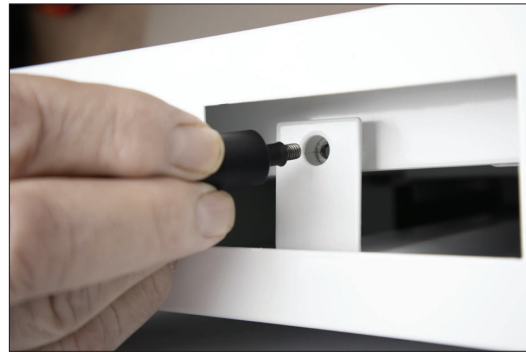

Unscrew and remove Shipping Screw.

Carrying Handle Installation

After removing the shipping screws and before using the scale, it will be necessary to install the carrying handles. Refer to the images below and then follow the steps listed to install the carrying handles.

- Step 1** Insert the top of the carrying handle into the opening on the side of the scale enclosure. Make sure the top of the carrying handle is flush against the enclosure.
- Step 2** With the carrying handle inserted into the opening and flush with the enclosure, swing the bottom of the carrying handle into the opening and then gently using the palm of your hand, tap the carrying handle in place.
- Step 3** Repeat steps 1 and 2 for the carrying handle on the other side of the scale enclosure.



Insert top of Carrying Handle into opening flush with enclosure.



Swing bottom of Carrying Handle into opening and tap in place.

INSTALLATION, CONT.

Level Adjustment

1. Remove the four leveling feet from the hardware pack and install them in each corner of the bottom of the scale base assembly.

NOTE: The leveling feet must be in place to operate the scale.

2. Next, check to make certain the scale is level. The level indicator is located in the center of the weighbridge under the baby tray.
3. If the scale is not level (the bubble will not be centered), loosen the locking nut on all four (4) leveling feet and adjust them as required to center the bubble and attain a level scale.
4. Once a level condition has been obtained, lock the leveling feet in place by tightening the adjustment nuts against the bottom of the scale.

Baby Tray Installation

Before using the scale, it will be necessary to install the baby tray and batteries if used. Note that the baby tray is designed to lock into place on the scale weighbridge preventing accidental separation from the scale. Follow the steps listed below to install the baby tray.

Step 1 Place the scale on a tabletop.

Step 2 Position the baby tray onto the weighbridge.



WARNING! DO NOT LIFT THE SCALE OR CARRY IT BY THE BABY TRAY. LIFTING THE SCALE BY THE TRAY MAY RESULT IN SEVERE INJURY AND DAMAGE TO THE SCALE.

Placing the Scale

After the baby tray has been installed, the scale may be prepared for use. Place the scale on a stable, vibration-free level surface away from direct sunlight and from any rapidly moving air source (heating/cooling vents, fans, etc.). Make certain the power cord and peripheral cables are routed out of the way of normal traffic. If the scale is unstable, adjust the front legs up or down as necessary until the scale is stable.



WARNING! Make certain that the structure beneath the scale is of sufficient strength to hold both the scale AND the maximum load to be placed on the scale. Failure of the supporting structure can result in severe injury to the baby in the baby tray, as well as damage to the scale.

AC Power Adapter

To power the scale using the included Medical Grade Power Supply, connect the plug from the power supply to the power jack on the back of the scale, and then plug the power cord from the power supply into the proper electrical outlet.

Installation of the scale is now complete. Please read the operating instructions contained in this manual before attempting to operate your scale.

INSTALLATION, CONT.

Battery Operation

The DETECTO 6745 Digital Baby Scale can use six C-size Alkaline, Ni-Cad, or NiMH batteries (*not included*). If you plan to operate the scale using batteries, you must first obtain and install the batteries before operations can begin. The batteries are housed in a holder attached to a removable panel on the bottom of the scale, secured with a thumbscrew.



CAUTION! The scale can be operated from Alkaline, Ni-Cad, or NiMH batteries. All six batteries must be of the same type. They must all be Alkaline, all Ni-Cad, or all NiMH. **DO NOT** mix Alkaline and Ni-Cad or NiMH batteries.



NOTE: The scale does not have a battery charging circuit. Should you wish to use rechargeable batteries (Ni-Cad or NiMH), they must be fully charged before installation. When discharged, the Ni-Cad or NiMH batteries must be removed and placed in an external charger to recharge.

Battery Status

The battery status will be displayed when the batteries are installed. A number will be displayed in the upper right corner of the touchscreen indicating the level of charge remaining in the batteries. For example, 100 = 100% charge, 75 = 75% charge, etc...

When the batteries are at the point where they need to be replaced (Alkaline) or recharged (NiCad or NiMH) and the battery voltage drops too low for accurate weighing, the scale will automatically shut off and you will be unable to turn it back on.

Using Alkaline Batteries

When the batteries are low enough that the scale turns off, remove the old batteries, and replace them with new ones.

Using NiCad or NiMH Batteries

When the batteries are low enough that the scale turns off, remove the discharged batteries, and replace them with fully charged ones. Place the discharged batteries in an external charger to recharge.

INSTALLATION, CONT.

Battery Installation or Replacement

Use the following procedure to install new or replace old batteries:

1. With the baby tray installed, turn the scale upside down on a stable surface.
2. Locate the rectangular panel on the bottom of the scale and remove the thumb screw retaining it. Refer to the image on the previous page.
3. Remove the panel (lift straight up and slide it out) exposing the battery holder.
4. When installing new batteries, proceed to step 5. If replacing the batteries, remove all six batteries from the battery holder and then proceed to step 5.
5. Install six new C-size batteries in the holder, noting the polarity markings located in the battery holder. Refer to the figure below.

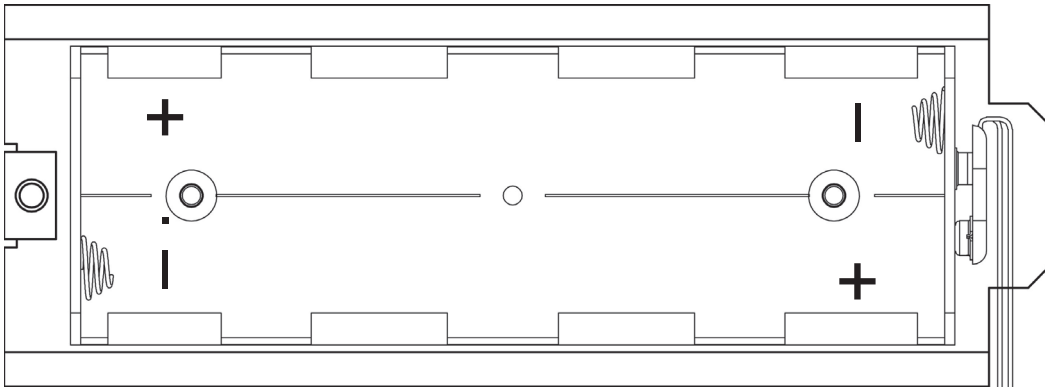

6. After placing all six batteries in the holder, replace the panel on the bottom of the scale (slide the tab in the slot on the scale) and install the thumbscrew.
7. Turn the scale over and press the  key to turn the scale on.
8. If the display turns on, the batteries have been installed correctly. If not, turn the scale over, remove the panel, and check for one or more improperly positioned batteries.
9. Your 6745 Digital Baby Scale is now ready for operation.

KEYPAD FUNCTIONS



DO NOT operate the keys or touchscreen with pointed objects (pencils, pens, etc.). Damage to the keys or touchscreen resulting from this practice is not covered under warranty.



This is the **POWER** key. With the scale off, pressing this key will apply power to the scale and turn on the display. If the scale is already on, pressing this key will turn it off.

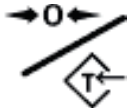

This is the **ZERO/TARE** key. Press and release this key to reset the display to zero.

When this key is pressed with weight on the scale platform, the display will zero or tare off the weight up to 100% of the scale capacity, and the display will change to zero (0.0). When the weight is removed, the display will show a negative weight. Press the **ZERO/TARE** key again to reset the display to zero (0.0).



This is the **RECALL** key. Press this key to recall the last five (5) locked weight readings. Note that the recalled weight will include the date and time the weight was locked and saved.



This is the **ENTER** key. It serves two purposes. First, pressing and releasing this key is used to signal the completion of data entry and cause the scale to output the current date, time, and weight for data capture for EMR/EHR purposes. *Note that the output is in TEXT format.*

Second, the **ENTER** key is used as a Print key when using the Wi-Fi features of the scale. Pressing and releasing the **ENTER** key will signal the completion of data entry and cause the scale to output (print) the current date, time, and weight using the Wi-Fi wireless transmitter.



This is the **LOCK/UNLOCK** key. Press and release this key to cause the weight to lock on the current value until the key is pressed again. While the weight is locked, the weight status will change to LOCKED to denote that the weight is being held.



This is the **MENU** key. Press and release this key to launch the Menu screen. The first screen that is displayed is the Setup Review screen where you can see all of the settings at a glance. To continue into setup, touch the Setup key at the bottom right of the touchscreen.



This is the **REWEIGH** key. Press this key from any screen to escape the current screen and return to the weight screen.

KEYPAD FUNCTIONS, CONT.

Soft Keys

MILK

This key is used with the Breastmilk Intake feature. With this feature, the infant is weighed before nursing and again after nursing. The scale will then display the difference in the weights which will equal the amount of breastmilk the infant has consumed.

ID

This is the **ID** key. Press and release this key to open the PATIENT ID entry screen, and then using the touchscreen, enter a numeric ID. To change or edit the ID, simply press the **ID** key again to return to the ID entry screen.



IMPORTANT! The **ID** key will not be shown on the weight screen unless it is enabled in SCALE SETUP.

DIAPER

This key is used with the Diaper Weight Feature. With this feature, a new diaper is weighed before placing it on an infant and then weighed again after it has been used and removed from the infant. The scale will then display the difference in the weights which will equal the amount of fluid output of the infant.

ANNUNCIATORS

The annunciators are displayed on the Weight screen to show that the indicator is in the mode corresponding to the annunciator label or that the status indicated by the label is active.

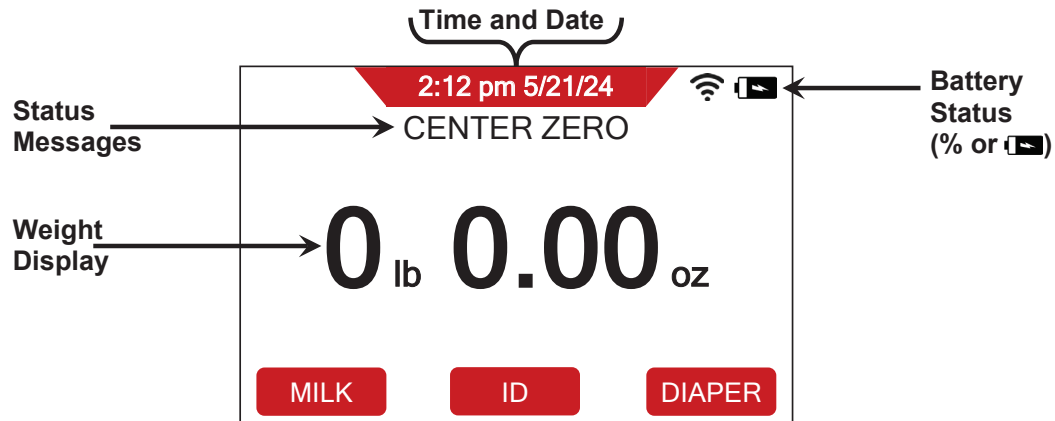

Time and Date

This is shown on the Weight screen to indicate the current time and date.

lb

This is shown on the Weight screen to indicate that the weight displayed is in pounds (lb).

kg

This is shown on the Weight screen to indicate that the weight displayed is in kilograms (kg).

lb/oz

This is shown on the Weight screen to indicate that the weight displayed is in pounds (lb) and ounces (oz).

CENTER ZERO / → 0 ←

This is shown on the Weight screen to indicate that the weight is within +/- 1/4 division of the center of zero.

LOCK

This is shown on the Weight screen to indicate that the indicator is locked onto the displayed weight. In operation after obtaining a stable weight value, pressing the  key will cause the indicator to lock onto the weight and turn on the annunciator. Pressing this key, a second time will unlock the indicator and turn off the annunciator.

Battery Status

The battery status will be shown on the Weight screen when batteries are installed. A number will be displayed in the upper right corner of the touchscreen indicating the level of charge remaining in the batteries. For example, 100 = 100% charge, 75 = 75% charge, etc..

(AC Power)

This is shown on the Weight screen instead of the battery status percentage to indicate that the indicator is powered by the AC power adapter.

(Wi-Fi Connection)

This is shown on the Weight screen to indicate the scale is connected to a Wi-Fi network.

OPERATION

The following steps describe the operation of the DETECTO 6745 Digital Baby Scale. Note that a set of condensed instructions appears on the face of the scale as well.



NEVER leave an infant or child unattended while on the scale. Failure to maintain control of the infant or child at all times while they are on the scale can result in severe injury to the infant or child.

Basic Weighing Operation

1. Press the **POWER** key to turn the scale on.
2. If desired, a blanket or similar covering may be placed in the baby tray at this time. Make certain that the blanket does not extend over the tray and touch surrounding objects (including the scale enclosure) or the weight reading could be incorrect.
3. Press the **ZERO/TARE** key to *zero or tare off* the blankets or similar covering and make certain that the display shows a zero weight reading.
4. Place the baby in the baby tray.
5. When the weight is stable, a beep will sound, the weight reading will automatically lock and **AUTO LOCKED** will be displayed. Note that the amount of time the reading will hold is dependent upon the Auto Locking setting in Setup.
NOTE: If more time is needed, press the **LOCK/UNLOCK** key to hold the locked weight reading.
6. Remove the baby from the scale.
7. Record the baby's weight from the weight display.

OPERATING HINTS

- A. Remember that all items (blankets, pads, toys, etc.) that are not to be included in the weight should be placed on the baby tray and the **ZERO/TARE** key pressed. This will ensure that the item(s) will not be included in the infant's weight.
- B. If the infant is too active it may take a few seconds longer for the Weight Lock annunciator to turn on.

OPERATION, CONT.

Basic Weighing Operation with ID



IMPORTANT! The **ID** key will not be shown on the weight screen unless it is enabled in **SCALE SETUP**.

1. Press the **POWER** key to turn the scale on.
2. If desired, a blanket or similar covering may be placed in the baby tray at this time. Make certain that the blanket does not extend over the tray and touch surrounding objects (including the scale enclosure) or the weight reading could be incorrect.
3. Press the **ZERO/TARE** key to *zero or tare off* the blankets or similar covering and make certain that the display shows a zero weight reading.
4. Press the **ID** key on the touchscreen.

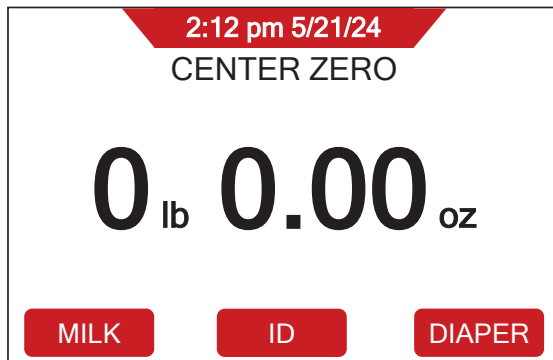

5. The display will change to show the **PATIENT ID** screen.

PATIENT ID				
12345678		1	2	3
Key in the numeric patient ID to be transmitted when the Print key is pressed.		4	5	6
		7	8	9
		SAVE	CANCEL	0

6. Using the numeric keys, enter up to an 8-digit numeric identification number for the patient, and then press **SAVE**.
7. Place the baby in the baby tray.
8. When the weight is stable, a beep will sound, the weight reading will automatically lock and **AUTO LOCKED** will be displayed. Note that the amount of time the reading will hold is dependent upon the Auto Locking setting in Setup.
NOTE: If more time is needed, press the **LOCK/UNLOCK** key to hold the locked weight reading.
9. Remove the baby from the scale.
10. Read and record the baby's weight from the weight display.
11. If "Auto" has been selected for the **Print:** setting in Setup, the scale will output EMR/EHR data when the weight reading has been Auto Locked.

If "Manual" has been selected for the **Print:** setting in Setup, press the **ENTER** key to output EMR/EHR data when the weight is stable.

OPERATION, CONT.

Breastmilk Intake Feature

The DETECTO 6745 Digital Baby Scale includes a breastmilk intake feature for accurately measuring an infant's milk consumption. This feature involves weighing the baby before and after nursing, with the scale displaying the difference in weight to indicate the amount of breastmilk consumed. Note that the scale offers five memory slots to store the infant's weights.

Before Nursing

1. Press the **MILK** soft key on the touchscreen main weight screen.

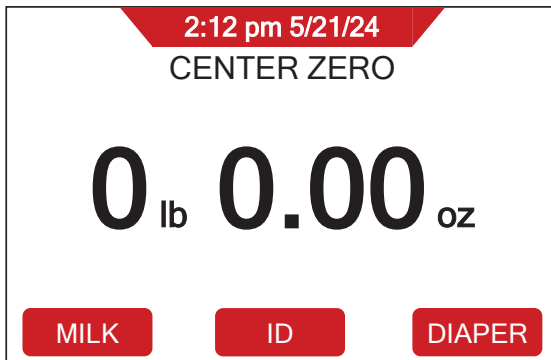

2. The display will change to show the BEFORE NURSING/AFTER NURSING screen.

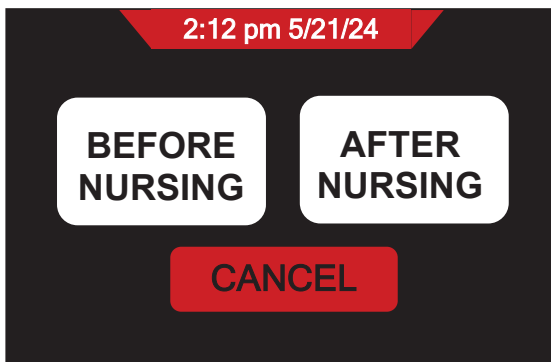

3. Press the **BEFORE NURSING** button on the touchscreen.
NOTE: If the **CANCEL** button is pressed, the display will return to the main weight screen.
4. The display will change to show the PATIENT ID screen with a numeric keypad and prompt to enter the infant patient ID.

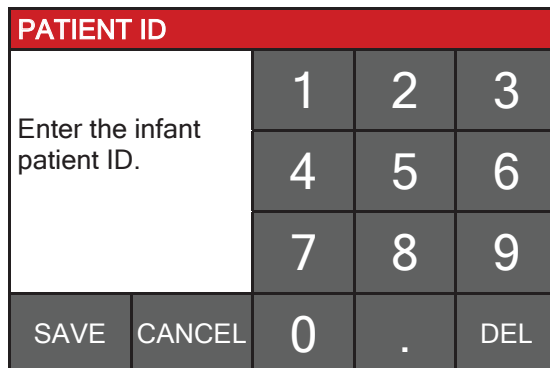

5. Using the numeric keys, enter up to an 8-digit numeric identification number for the infant patient ID, and then press **SAVE**.

NOTE: If the **CANCEL** button is pressed, the display will return to the main weight screen.

OPERATION, CONT.

Before Nursing, Cont.

- Place the baby on the scale to record their weight before nursing.

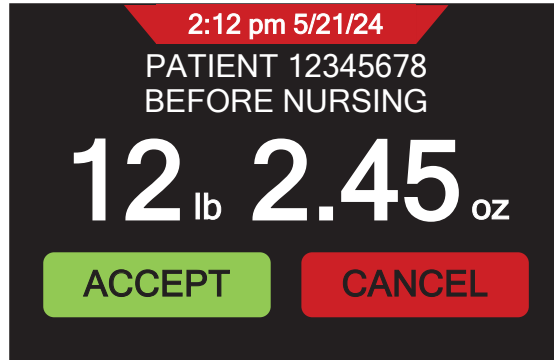

- Press the **ACCEPT** button on the touchscreen.

NOTE: If the **CANCEL** button is pressed, the display will return to the main weight screen.

- The screen will change to show the memory location slots where the weight can be stored.

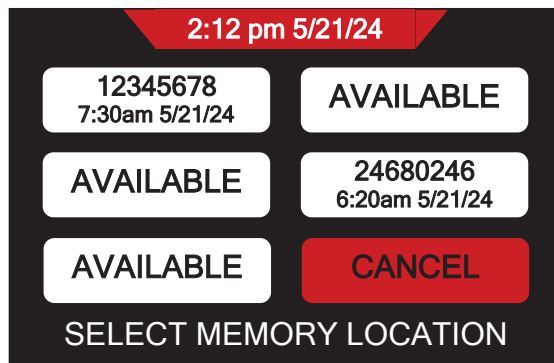

- The operator can then select one of the five (5) memory location slots where the data will be stored.
 - Empty locations will show the word "AVAILABLE".
 - If the location selected already contains data, the data will be overwritten.
 - After a memory location has been selected, the weight, units, patient ID, and date and time will be stored in that memory location and the display will return to the main weight screen.
 - If the **CANCEL** button is pressed, the display will return to the main weight screen and the data is discarded.
- Press the selected memory location button on the touchscreen.
- The display will return to the main weight screen.
- Remove the baby from the scale and begin nursing

OPERATION, CONT.

After Nursing

1. Press the **MILK** soft key on the touchscreen main weight screen.

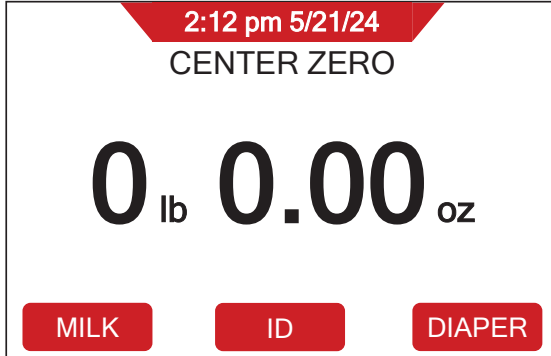

2. The display will change to show the BEFORE NURSING/AFTER NURSING screen.

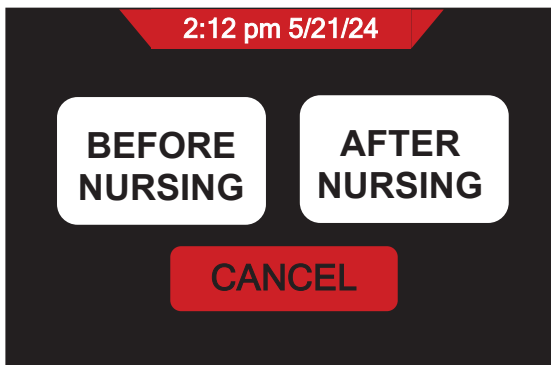

3. Press the **AFTER NURSING** button on the touchscreen.

NOTE: If the **CANCEL** button is pressed, the display will return to the main weight screen.

4. The screen will change to show all the previously entered IDs with the date and time they were recorded. Each of these is selectable except for empty memory locations which will be blank (white with no text).

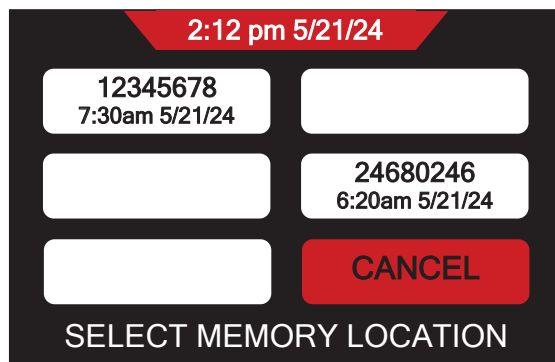

5. Place the baby on the scale and then press the memory location button on the touchscreen associated with the infant patient ID.

NOTE: If the **CANCEL** button is pressed, the display will return to the main weight screen.

OPERATION, CONT.

After Nursing, Cont.

6. The screen will change to the weight display with the current weight on the scale and show the **ACCEPT** and **CANCEL** buttons.

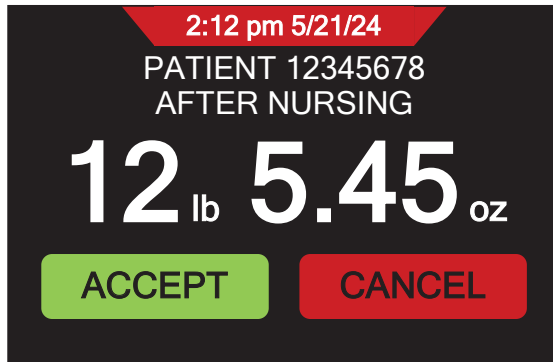

7. Press the **ACCEPT** button on the touchscreen.
NOTE: If the **CANCEL** button is pressed, the display will return to the main weight screen.
8. The screen will change to show the PATIENT ID, the NET WEIGHT CHANGE (*AFTER NURSING WEIGHT minus BEFORE NURSING WEIGHT*), and a **RETURN** button.

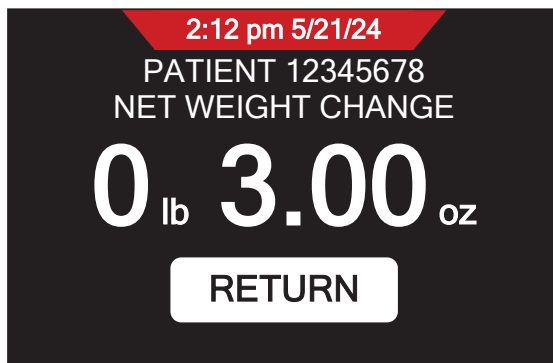

9. Read and record the net weight change from the weight display.
10. Remove the baby from the scale.
11. Press the **RETURN** button to clear the memory slot used by the patient.
12. The display will return to the main weight screen.

OPERATION, CONT.

Diaper Weight Feature

The DETECTO 6745 Digital Baby Scale includes a diaper weight feature that allows for precise measurement of an infant's fluid output. This feature involves weighing a new diaper before placing it on the baby, and then weighing the diaper again after it has been used. The scale then calculates and displays the difference in weight, representing the infant's fluid output. Note that the scale includes five memory slots to store diaper weights.

New Diaper

1. Press the **DIAPER** soft key on the touchscreen main weight screen.

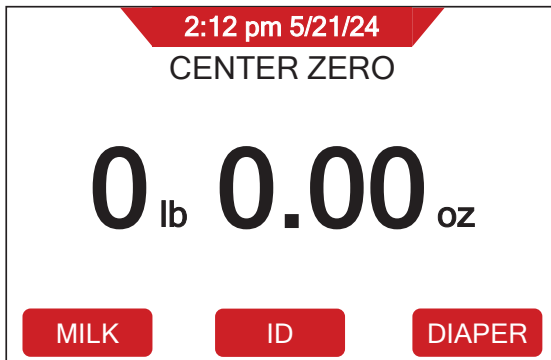

2. The display will change to show the NEW DIAPER/USED DIAPER screen.



3. Press the **NEW DIAPER** button on the touchscreen.
NOTE: If the **CANCEL** button is pressed, the display will return to the main weight screen.
4. The display will change to show the PATIENT ID screen with a numeric keypad and prompt to enter the infant patient ID.

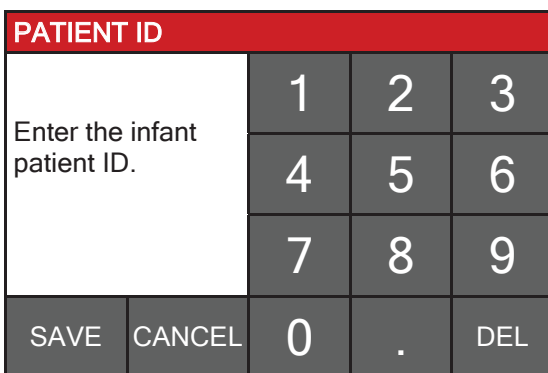

5. Using the numeric keys, enter up to an 8-digit numeric identification number for the infant patient ID, and then press **SAVE**.

NOTE: If the **CANCEL** button is pressed, the display will return to the main weight screen.

OPERATION, CONT.

New Diaper, Cont.

- Place the new diaper on the scale to record its weight before placing it on the infant.

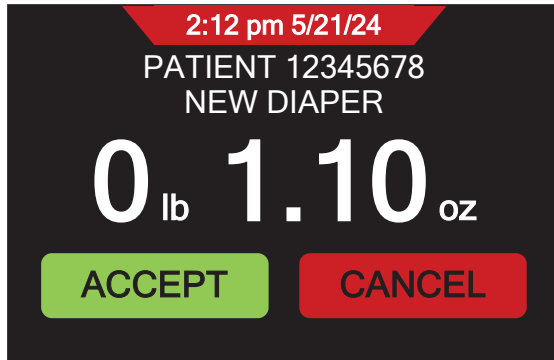

- Press the **ACCEPT** button on the touchscreen.
NOTE: If the **CANCEL** button is pressed, the display will return to the main weight screen.
- The screen will change to show the memory location slots where the weight can be stored.

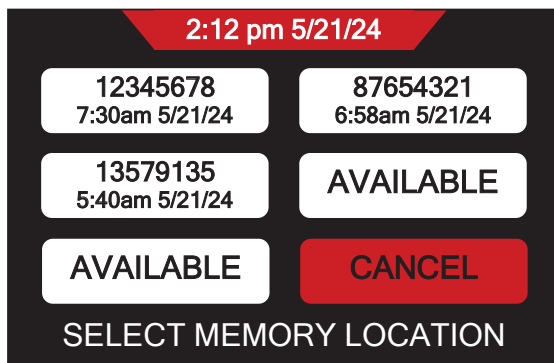

- The operator can then select one of the five (5) memory location slots where the data will be stored.
 - Empty locations will show the word "AVAILABLE".
 - If the location selected already contains data, the data will be overwritten.
 - After a memory location has been selected, the weight, units, patient ID, and date and time will be stored in that memory location and the display will return to the main weight screen.
 - If the **CANCEL** button is pressed, the display will return to the main weight screen and the data is discarded.
- Press the selected memory location button on the touchscreen.
- The display will return to the main weight screen.
- Remove the diaper from the scale and place it on the infant.

OPERATION, CONT.

Used Diaper

1. Press the **DIAPER** soft key on the touchscreen main weight screen.

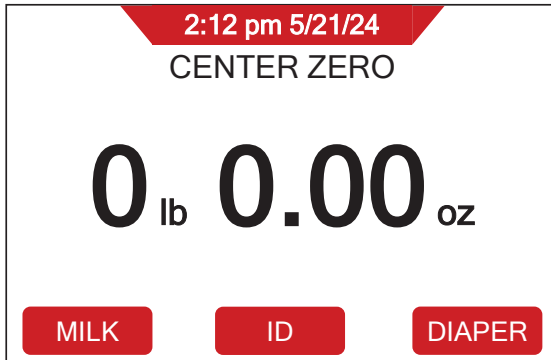

2. The display will change to show the NEW DIAPER/USED DIAPER screen.

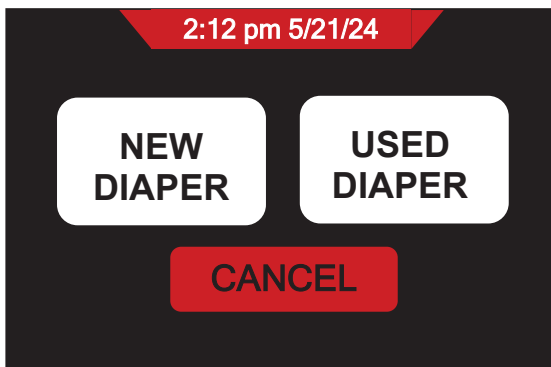

3. Press the **USED DIAPER** button on the touchscreen.

NOTE: If the **CANCEL** button is pressed, the display will return to the main weight screen.

4. The screen will change to show all the previously entered IDs with the date and time they were recorded. Each of these is selectable except for empty memory locations which will be blank (white with no text).

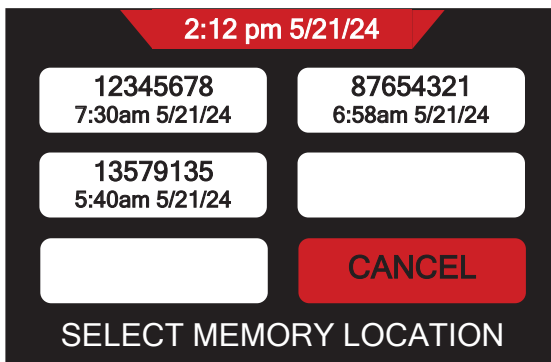

5. Place the used diaper on the scale and then press the memory location button on the touchscreen associated with the infant patient ID.

NOTE: If the **CANCEL** button is pressed, the display will return to the main weight screen.

OPERATION, CONT.

Used Diaper, Cont.

6. The screen will change to the weight display with the current weight on the scale and show the **ACCEPT** and **CANCEL** buttons.

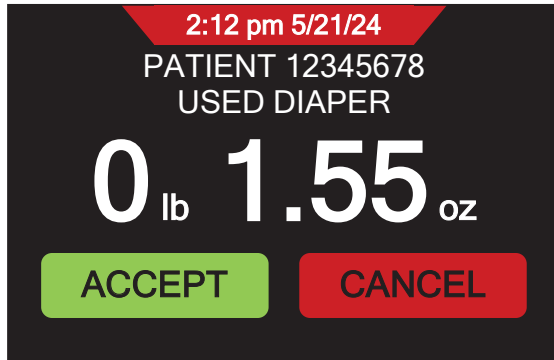

7. Press the **ACCEPT** button on the touchscreen.
NOTE: If the **CANCEL** button is pressed, the display will return to the main weight screen.
8. The screen will change to show the PATIENT ID, the DIAPER WEIGHT CHANGE (*USED DIAPER WEIGHT minus NEW DIAPER WEIGHT*), and a **RETURN** button.

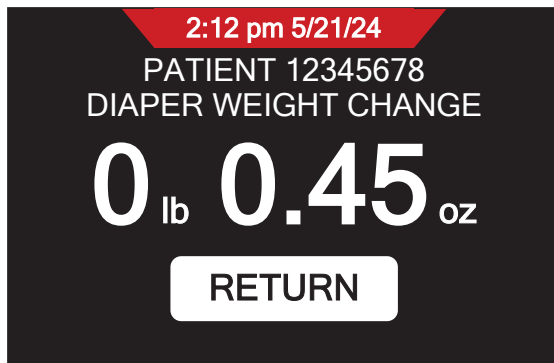

9. Read and record the diaper weight change from the weight display.
10. Remove the used diaper from the scale.
11. Press the **RETURN** button to clear the memory slot used by the patient.
12. The display will return to the main weight screen.

SCALE SETUP

Your DETECTO 6745 Digital Baby Scale has been pre-configured at the factory and should not require changes for use in most applications. However, if the factory settings do not meet the requirements of your operation, the following describes the setup process for your indicator.



NOTE: The keypad and touchscreen are not to be operated with pointed objects (pencils, pens, fingernails, etc.). Damage to the keypad or touchscreen resulting from this practice will NOT be covered under the warranty.

Menu Functions

After pressing the **Menu** key to enter the Setup menu, the first screen of the menu is a Setup Review screen where all of the settings can be reviewed at a glance. The Audit Trail Counters for the metrological settings and the non-metrological settings are available for review on this screen as well. Each prompt in the menu screens will show the current value of the setting next to the prompt to easily identify what the current setting for that parameter is.

Setup Menu Keys

- Press **Exit** to exit Setup and return to the Weight screen.
- Press **Setup** on the Settings Overview screen to enter the scale setup.
- Press >>> on the Settings screen to advance to the next menu page.
- Press <<< at the Settings screen to return to the previous menu page.

To Enter Setup

1. Press the  key to turn the indicator on.
2. The indicator will show the DETECTO logo briefly and then change to the Weight screen.
3. With the Weight screen displayed, press the **Menu** key.
4. The display will change to show the Settings Overview 1 screen.

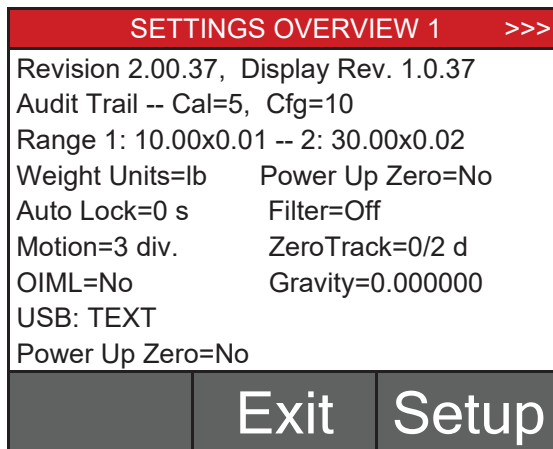

- Press >>> on the touchscreen to advance to the Settings Overview 2 screen.
- Press **Exit** to exit Setup and return to the Weight screen.
- Press **Setup** to advance to the Password screen and proceed with scale setup.

SCALE SETUP, CONT.

To Enter Setup, Cont.

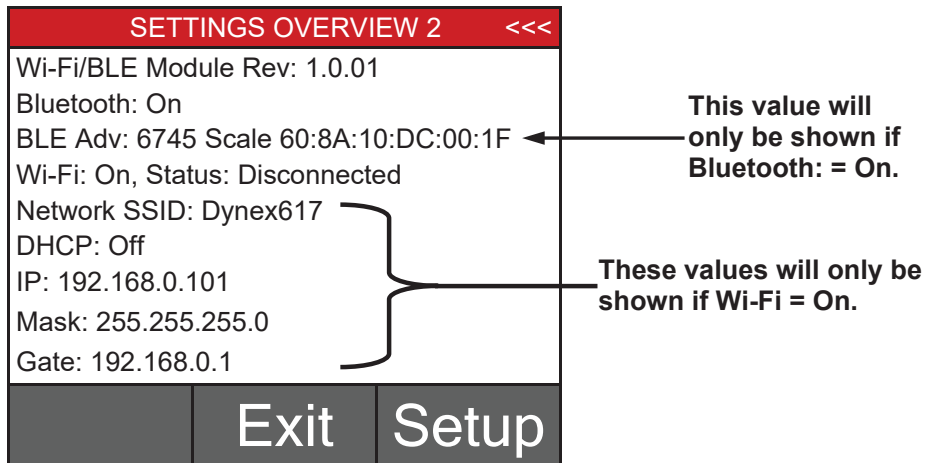

- Press <<< on the touchscreen to return to the Settings Overview 1 screen.
 - Press **Exit** to exit Setup and return to the Weight screen.
 - Press **Setup** to advance to the Password screen and proceed with scale setup.
5. After pressing **Setup** on the touchscreen, the display will change to show the ENTER PASSCODE screen.

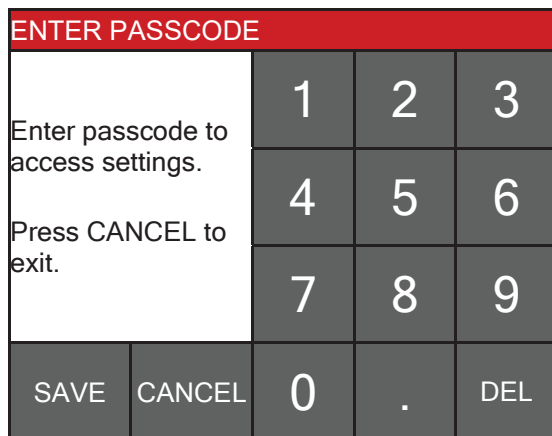

6. Using the 10-key on the touchscreen, enter **64870** and then press **Save**.
7. The scale is now ready for setup and calibration.

SCALE SETUP, CONT.

Settings Page 1

SETTINGS		PAGE 1
Model: 6745		
Date: 7/30/2024		
Time: 10:24:44		
Language: English		
<<<	Exit	>>>

Model:

This selection sets the default settings and operation of the scale and should be set to “6745” to use the software designed for the 6745 Digital Baby Scale

Date:

Touching this key allows you to enter the date, starting with the year. After pressing **Date:** the touchscreen will show “Key in the Year and press SAVE”.

Year

Enter the 4 digits (YYYY) for the year and then press **Save**.

Month

Enter the 2 digits (MM) for the month and then press **Save**.

Day

Enter the 2 digits (DD) for the day and then press **Save**.

Time:

Touching this key allows you to enter the time starting with the hour. After pressing **Time:** the touchscreen will show “Key in the Hour HH”.

Hour

Enter the 2 digits (HH) for the hour and then press **Save**.

Minute

Enter the 2 digits (MM) for the minute and then press **Save**.

Second

Enter the 2 digits (SS) for the seconds and then press **Save**.

Language:

This will change the language for the Setup and Operation screens of the scale.

Touch this key to open the language selection screen. Using the numeric keys, enter a new setting, and then press **Save**.

Allowable settings are 0 = English, 1 = Spanish, 2 = German, 3 = French

- Press >>> to advance to Settings Page 2.
- Press <<< to return to the Settings Overview screen.
- Press **Exit** to exit Setup and return to the Weight screen.

SCALE SETUP, CONT.

Settings Page 2

SETTINGS		PAGE 2
OIML: No		
Units: lb oz		
Filter Mode: 0		
Zero Tracking: 10		
<<<	Exit	>>>

OIML:

Touching this key will toggle the OIML setting to Yes or No. **NOTE:** This setting should be enabled for all EU models to comply with regulations.

Allowable settings for OIML are Yes or No.

Units:

Touching this key will toggle the weighing units between lb, kg, or lb/oz.

Allowable settings are lb (pounds), kg (kilograms), or lb/oz (pounds/ounces).

Filter Mode:

Pressing this key will open the weight filtering screen. This will allow you to set the amount of digital filtering being applied to the scale. Using the numeric keys, enter a new setting, and then press **Save**.

Allowable settings are 0 = Off, 1 = Minimal, 2 = Moderate, and 3 = Maximum

Zero Tracking:

Touching this key will open the zero-tracking screen. This will allow you to set the number of half (1/2) divisions that the scale will attempt to maintain zero. Using the numeric keys, enter a new setting, and then press **Save**.

Allowable settings for Zero Tracking are 0 – 20.

NOTE: Entering 0 (zero) will disable zero tracking.

- Press >>> to advance to Settings Page 3.
- Press <<< to return to Settings Page 1.
- Press **Exit** to exit Setup and return to the Weight screen.

SCALE SETUP, CONT.

Settings Page 3

SETTINGS		PAGE 3
Capacity 1: 10.00		
Capacity 2: 30.00		
Interval 1: 2		
Interval 2: 5		
<<<	Exit	>>>

Capacity 1:

Touching this key will open the Capacity 1 screen. This will allow you to set the capacity of the scale. The setting for Capacity 1 should be set to 10.0.

If the setting for Capacity 1 is not 10.0, touch this key to open the Capacity 1 screen. Using the numeric keys enter **10.0**, and then press **Save**.

Capacity 2:

Touching this key will open the Capacity 2 screen. This will allow you to set the capacity of the scale. The setting for Capacity 2 should be set to 30.0.

If the setting for Capacity 2 is not 30.0, touch this key to open the Capacity 1 screen. Using the numeric keys enter **30.0**, and then press **Save**.

Interval 1:

Touching this key will open the interval entry screen. This will allow you to set the scale interval. The setting for Interval 1 should be set to 2.

If Interval 1 is not 2, touch this key to open the Interval 1 screen. Using the numeric keys enter a 2, and then press **Save**.

Interval 2:

Touching this key will open the interval entry screen. This will allow you to set the scale interval. The setting for Interval 2 should be set to 5.

If Interval 2 is not 5, touch this key to open the Interval 2 screen. Using the numeric keys enter a 5, and then press **Save**.

- Press >>> to advance to Settings Page 4.
- Press <<< to return to Settings Page 2.
- Press **Exit** to exit Setup and return to the Weight screen.

SCALE SETUP, CONT.

Settings Page 4

SETTINGS		PAGE 4
Decimal 1: 2		
Decimal 2: 2		
Motion Range: 3		
Gravity: 0.000000		
<<<	Exit	>>>

Decimal 1:

Touching this key will open the Decimal 1 entry screen. This will allow you to set the decimal point precision for the first weight range. Using the numeric keys, set Decimal 1 to 3, and then press **Save**.

Allowable settings for Decimal 1 are 0 – 3.

Decimal 2:

Touching this key will open the Decimal 2 entry screen. This will allow you to set the decimal point precision for the second weight range. Using the numeric keys, set Decimal 2 to 3, and then press **Save**.

Allowable settings for Decimal 2 are 0 – 3.

Motion Range:

Touching this key will open the motion range entry screen. This will allow you to set the number of scale divisions of movement that will be allowed for a stable weight. Using the numeric keys, enter a new setting, and then press **Save**.

Allowable settings for Motion Range are 0 – 20.

Gravity:

Gravity compensation accounts for latitudes and elevations that are different from where the scale was calibrated. To calculate the setting for this parameter, use the gravitational constant of the location where the scale was calibrated divided by the gravitational constant of where the scale will be installed:

$$\frac{\text{Gravitational Constant (Calibration location)}}{\text{Gravitational Constant (Operation location)}} = \text{setting}$$

This should give you a setting close to 1 that you can enter to compensate for variations in gravity due to elevation/latitude.

Touching this key will open the gravity compensation entry screen. Using the numeric keys, enter a new setting, and then press **Save**.

NOTE: Set Gravity to 0 (zero) to disable the gravity compensation feature.

- Press >>> to advance to Settings Page 5.
- Press <<< to return to Settings Page 3.
- Press **Exit** to exit Setup and return to the Weight screen.

SCALE SETUP, CONT.

Settings Page 5

SETTINGS		PAGE 5
LFT: No		
Calibrate Scale		
Power up Zero: No		
Auto Locking: 0 s		
<<<	Exit	>>>

LFT: (Legal For Trade)

Touching this key will toggle the LFT (Legal For Trade) setting to Yes or No. **NOTE:** This setting should be enabled to comply with NTEP regulations.

Allowable settings for LFT are Yes or No.

NOTE: If LFT = Yes, the following default values will be set:

Pounds (lb):	Kilograms (KG):
Capacity 1: 10	Capacity 1: 5
Capacity 2: 30	Capacity 2: 15
Interval 1: 2	Interval 1: 1
Interval 2: 5	Interval 2: 2
Decimal 1: 3	Decimal 1: 3
Decimal 2: 3	Decimal 2: 3

IMPORTANT!
When LFT = Yes:

- **Units: cannot be lb/oz (pounds/ounces).**
- **Zero Tracking: is set to 0 (disabled).**

Calibrate Scale

Touching this key will allow for calibration of the scale. Refer to the **CALIBRATION** section of this manual for instructions to select the calibration mode and how to perform calibration.

Power up Zero:

Touching this key will toggle the power up zeroing of the scale to Yes or No. If enabled, this will cause the scale to attempt to zero the scale upon power up.

Allowable settings for Power up Zero are Yes or No.

Auto Locking:

This setting is used by the scale to hold a stable patient weight for a desired amount of time. For example, if a setting of 5 seconds is used, then when the scale locks onto a stable patient weight, it will remain locked for 5 seconds before automatically releasing the weight.

Touching this key will open an entry screen for the auto-locking feature of the scale. The setting entered is a time in seconds. Using the numeric keys, enter a new setting, and then press **Save**.

Allowable settings for Auto Locking are 0 to 10.

NOTE: Selecting 0 will disable Auto Locking.

- Press >>> to advance to Settings Page 6.
- Press <<< to return to Settings Page 4.
- Press **Exit** to exit Setup and return to the Weight screen.

SCALE SETUP, CONT.

Settings Page 6

SETTINGS		PAGE 6
Serial Type: TEXT		
USB: TEXT		
Print: Auto		
Time Format: 12 hr		
<<<	Exit	>>>

Serial Type:

The factory setting for Serial Type is set to TEXT.

If the Serial Type is not TEXT, touch this key to open the Serial Type Selection screen. Using the numeric keys enter a 0, and then press **Save**.

USB:

The factory setting for the USB Port is set to TEXT.

If the USB Port is not TEXT, touch this key to open the USB Port selection screen. Using the numeric keys enter a 0, and then press **Save**.

NOTE: An example of the Serial and USB output format is:

GROSS: 30.168 lb[CR][LF][LF][LF][LF][LF][LF][LF][LF][LF]

Print:

Touching this key will toggle the Print setting to Auto or Manual for printing (outputting data) when an Auto Lock has been obtained on the scale.

- If "Auto" is selected, the scale will automatically print (output data) when the weight reading has been Auto Locked.
- If "Manual" is selected, after a stable weight has been obtained, you must press the  key to print (output data).

Allowable settings for Print are 0 = Manual, 1 = Auto

Time Format:

Touching this key allows you to select the time format.

Allowable settings for Time Format are 12 hr or 24 hr.

Time Format = 12 hr
12 hour clock (AM/PM)

(8:30 PM will display/print as 08:30 PM)

Time Format = 24 hr
24 hour clock

(8:30 PM will display/print as 20:30)

- Press >>> to advance to Settings Page 7.
- Press <<< to return to Settings Page 5.
- Press **Exit** to exit Setup and return to the Weight screen.

SCALE SETUP, CONT.

Settings Page 7

SETTINGS		PAGE 7
Date fmt: MM/DD/YY		
ID Softkey: No		
<<<	Exit	>>>

Date fmt: (format)

Touching this key allows you to select the date format.

Allowable settings for Date fmt: (format) are MM/DD/YY or YY/MM/DD.

Date Format = MM/DD/YY

MM = Month (01 = Jan, 02 = Feb, etc.)

DD = Day (01 to 31)

YY = Year (2024, etc.)

Date Format = YY/MM/DD

YY = Year (2024, etc.)

MM = Month (01 = Jan, 02 = Feb, etc.)

DD = Day (01 to 31)

ID Softkey:

Touching this key will toggle the **ID** Softkey setting to Yes or No (enabled or disabled). If enabled, the **ID** softkey will be shown on the display between the **MILK** and **DIAPER** softkeys. See the example below.

Allowable settings for ID Softkey are Yes or No.

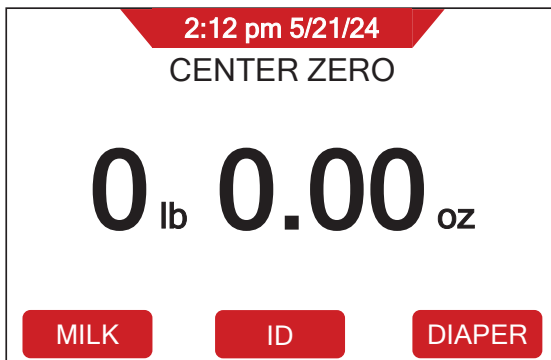

- Press >>> to advance to Settings Page 8.
- Press <<< to return to Settings Page 6.
- Press **Exit** to exit Setup and return to the Weight screen.

SCALE SETUP, CONT.

Settings Page 8, (Wi-Fi: = Off)

SETTINGS		PAGE 8
Bluetooth: Off		
Wi-Fi: Off		
Extend Weight: No		
<<<	Exit	

NOTE: The default Network Settings are Bluetooth: Off, Wi-Fi: Off, and DHCP: On.

Bluetooth:

Touch this key to open a selection screen to turn the Bluetooth 5.0 wireless transmitter “On” or “Off”. This setting should be “On” if pairing to a Bluetooth-capable device is desired. Using the numeric keys, enter a new setting, and then press **Save**.

Allowable settings for Bluetooth are 0 = Off, 1 = On

Wi-Fi:

Touch this key to open a selection screen to turn the Wi-Fi wireless transmitter “On” or “Off”. This setting should be “On” if interfacing through a Wi-Fi network is desired. Using the numeric keys, enter a new setting, and then press **Save**.

Allowable settings for Wi-Fi are 0 = Off, 1 = On

Extend Weight:

This setting is for factory use only and must always be set to **No**.



IMPORTANT! If the setting for Extend Weight: is set to **Yes**, touch this key to toggle it to **No**.

- Press >>> to advance to Settings Page 9.
- Press <<< to return to Settings Page 7.
- Press **Exit** to exit Setup and return to the Weight screen.

SCALE SETUP, CONT.

Settings Page 8, (Wi-Fi: = On)



NOTE: If the Wi-Fi setting is 1 = On, you will see the SSID: setting and the page advance (>>>) on the touchscreen to allow proceeding to Settings Page 9.

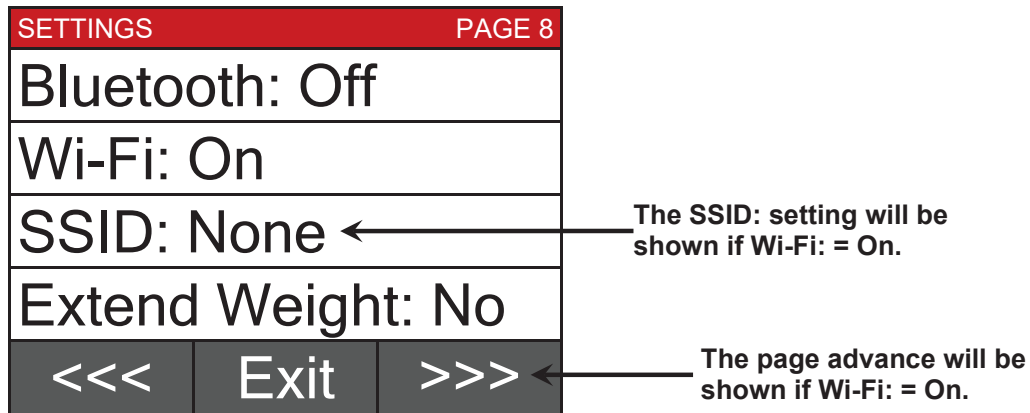

SSID:

This will show you the current SSID of the Wi-Fi network that is saved in memory for the 6745 to connect to.

Touching this key will prompt you to CLEAR SSID. Press 1 on the touchscreen, and then press **Save** to clear the Wi-Fi credentials.

- Press >>> to advance to Settings Page 9.
- Press <<< to return to Settings Page 7.
- Press **Exit** to exit Setup and return to the Weight screen.

SCALE SETUP, CONT.

Settings Page 9, (DHCP: = On)

SETTINGS		PAGE 9
DHCP: On		
IP: 192.168.0.133		
<<<	Exit	

DHCP:

Touching this key will open an entry screen to allow you to select the DHCP setting. This setting selects whether the Wi-Fi wireless transmitter will use a Dynamic IP address assigned by a DHCP server or a static IP address. Consult with your network administrator for the proper selection. Using the numeric keys, enter a new setting, and then press **Save**.

Allowable settings for DHCP are 0 = Off (Static IP), 1 = On (Dynamic IP)

IP: (Dynamic IP, address assigned by DHCP Server)

With **On** selected for the DHCP setting, the IP address assigned by the DHCP server will be shown.

IP: (Static IP)

With **Off** selected for DHCP: touching this key will open an entry screen to allow you to enter the IP Address for the scale. Using the numeric keys, enter a new setting, and then press **Save**.

The format for the IP Address is ### . ### . ### . ### (e.g., 192.168.0.101).

IMPORTANT! No other device on the network should have this IP address.

- Press <<< to return to Settings Page 8.
- Press **Exit** to exit Setup and return to the Weight screen.

SCALE SETUP, CONT.

Settings Page 9, (DHCP: = Off)



NOTE: If the setting for **DHCP: = Off** (Static IP), the settings for **NM:** (Netmask) and **GW:** (Gateway Address) will be shown on the touchscreen.

SETTINGS		PAGE 9
DHCP: Off		
IP: 192.168.0.133		
NM: 255.255.255.0		
GW: 192.168.0.1		
<<<	Exit	

The settings for **NM:**
and **GW:** will be
shown if **DHCP = Off.**

NM: (Netmask)

Touching this key will open an entry screen to allow you to enter the Wi-Fi network Netmask for the network the scale will be connected to. Using the numeric keys, enter a new setting, and then press **Save**.

The format for the Netmask is: ### . ### . ### . # (e.g., 255.255.255.0).

IMPORTANT! The Netmask of the scale should match the Netmask of the other computers on your network.

GW: (Gateway Address)

Touching this key will open an entry screen to allow you to enter the Wi-Fi network Gateway Address for the network the scale will be connected to. Using the numeric keys, enter a new setting, and then press **Save**.

The format for the Gateway Address is #, #, #, # (e.g., 192.168.0.1).

- Press <<< to return to Settings Page 8.
- Press **Exit** to exit Setup and return to the Weight screen.

CALIBRATE SCALE

Your 6745 Digital Baby Scale 6745 Scale was calibrated at the factory and should not require adjustment. If the scale should require re-calibration, the following describes the calibration procedure. To maintain the instrument's high degree of accuracy, a qualified technician should perform this function.

To perform calibration, you will need either 20 pounds or 10 kilograms of certified test weights, depending on the weighing unit (kilograms or pounds) of your scale.

To Enter Calibration

1. With the scale turned on and the Weight screen displayed, press the **Menu** key.
2. The display will change to show the Settings Overview 1 screen.

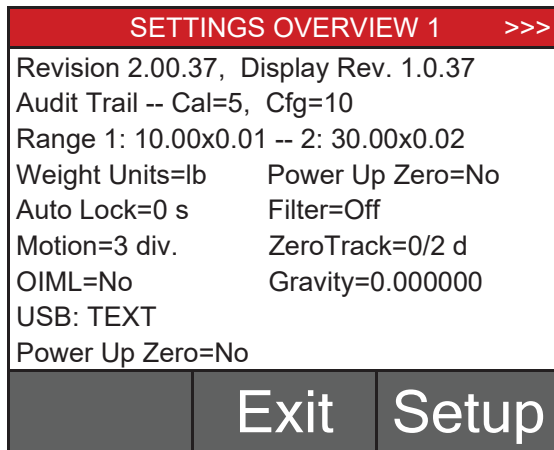

3. Press **Setup** on the touchscreen.
4. The display will change to show the ENTER PASSCODE screen.

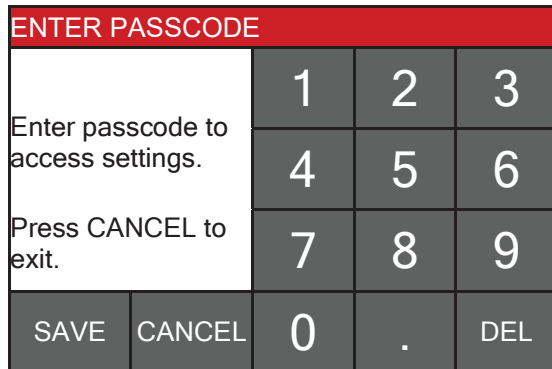

5. Using the 10-key on the touchscreen, enter **64870** and then press **Save**.

CALIBRATE SCALE, CONT.

To Enter Calibration, Cont.

6. The display will change to show the Settings Page 1 screen.

SETTINGS		PAGE 1
Model: 6745		
Date: 7/30/2024		
Time: 10:24:44		
Language: English		
<<<	Exit	>>>

7. Press >>> to advance to the Settings Page 5 screen.

SETTINGS		PAGE 5
LFT: No		
Calibrate Scale		
Power up Zero: No		
Auto Locking: 0 s		
<<<	Exit	>>>

8. Select **Calibrate Scale** from the Settings Page 5 screen.

9. The display will change to show the “Number of Points” screen.

CALIBRATE SCALE				
2 Number of points at which the scale will be calibrated.	1	2	3	
	4	5	6	
	7	8	9	
SAVE	CANCEL	0	.	DEL

10. With the “Number of Points” screen displayed, proceed to the next section of the manual to begin calibration.

CALIBRATE SCALE, CONT.

To Perform Calibration

1. With the “Number of Points” screen displayed, press **2** on the touchscreen and then press **Save**.

2 = Two Calibration Points (empty scale and full test load)

CALIBRATE SCALE				
2	1	2	3	
Number of points at which the scale will be calibrated.	4	5	6	
	7	8	9	
SAVE	CANCEL	0	.	DEL

2. The display will change to show “To calibrate zero, remove any weight from the scale before proceeding”. Make certain the scale is empty and then press **Save**.

CALIBRATE SCALE				
0	1	2	3	
To calibrate zero, remove any weight from the scale before proceeding	4	5	6	
	7	8	9	
SAVE	CANCEL	0	.	DEL

3. The display will change to show “Working” for a few seconds.

CALIBRATE SCALE				
Working	1	2	3	
To calibrate zero, remove any weight from the scale before proceeding	4	5	6	
	7	8	9	
SAVE	CANCEL	0	.	DEL

CALIBRATE SCALE, CONT.

To Perform Calibration, Cont.

- The display will then change to show the “Known test weight”
- Place the calibrated test weight (full test load) on the scale, enter the value for the test weight, and then press **Save**.

CALIBRATE SCALE				
20.0 This is the known test weight that is currently on the scale.		1	2	3
		4	5	6
		7	8	9
SAVE	CANCEL	0	.	DEL

NOTE: A minimum of 50% of the scale's capacity is required, however 70% to 100% is recommended.

- The display will change to show “Working” for a few seconds and then return to the Settings Page 5 screen.

CALIBRATE SCALE				
Working This is the known test weight that is currently on the scale.		1	2	3
		4	5	6
		7	8	9
SAVE	CANCEL	0	.	DEL

- Calibration is now complete.
- Press **Exit** to exit Setup and return to the Weight screen.

Wi-Fi AND BLUETOOTH 5.0

The DETECTO 6745 Scale has a Wi-Fi and Bluetooth 5.0 wireless transmitter inside the weight display that has been designed to interface the scale to a Wi-Fi network or pair it to a Bluetooth-capable device.

The following sections will guide you through the setup and operation of the Wi-Fi and Bluetooth 5.0 features of the scale.

Wi-Fi Features

- Soft Access Point (AP) for setting credentials for Wi-Fi module
- Setup option to select a static or dynamic IP address
- Built-in webserver to display weight
- TCP/IP connection for continuous output of weight

Wi-Fi SETUP

Enable and Configure Wi-Fi Networking

NOTE: Default Network Settings are Bluetooth: Off, Wi-Fi: Off, and DHCP: On.

1. With the scale turned on and the Weight screen displayed, press the **Menu** key.
2. The display will change to show the Settings Overview 1 screen.

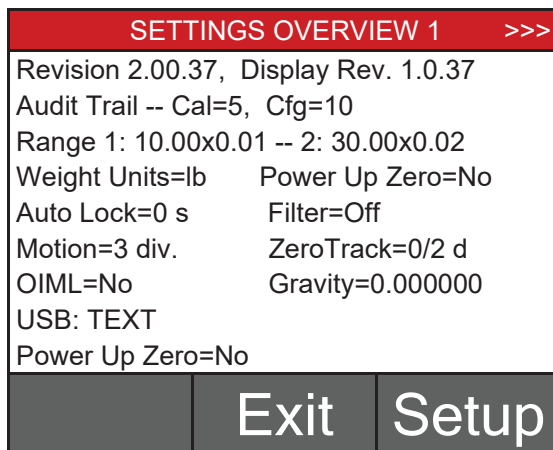

3. Press **Setup** on the touchscreen.
4. The display will change to show the ENTER PASSCODE screen.

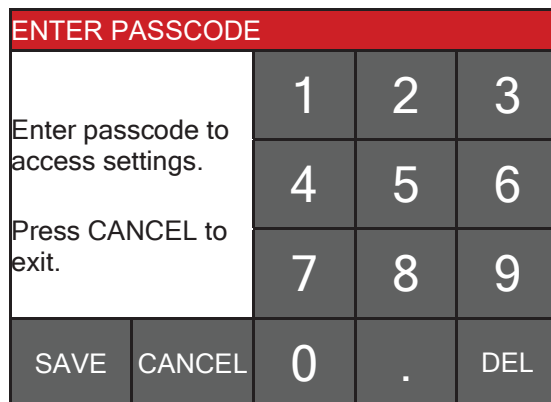

5. Using the 10-key on the touchscreen, enter **64870**, and then press **Save**.

Wi-Fi SETUP, CONT.

Enable and Configure Wi-Fi Networking, Cont.

6. The display will change to show the Settings Page 1 screen.

SETTINGS		PAGE 1
Model: 6745		
Date: 7/30/2024		
Time: 10:24:44		
Language: English		
<<<	Exit	>>>

7. Press >>> to advance to the Settings Page 8 screen.

SETTINGS		PAGE 8
Bluetooth: On		
Wi-Fi: Off		
Extend Weight: No		
<<<	Exit	>>>

8. Touch **Wi-Fi**: to open a selection screen to turn the Wi-Fi wireless transmitter “On”. Press 1 on the entry screen, and then press **Save**.

SETTINGS		PAGE 8
Bluetooth: On		
Wi-Fi: On		
SSID: Dynex617		
Extend Weight: No		
<<<	Exit	>>>

The SSID: setting will be shown if Wi-Fi: = On.

The page advance will be shown if Wi-Fi: = On.

Wi-Fi SETUP, CONT.

Enable and Configure Wi-Fi Networking, Cont.

9. Touch **SSID:** to open a screen that will prompt you to CLEAR SSID. Press **1** on the entry screen, and then press **Save** to clear the Wi-Fi credentials.

CLEAR SSID				
0 1= Clear wireless profile	1	2	3	
	4	5	6	
	7	8	9	
SAVE	CANCEL	0	.	DEL

10. Press >>> to advance to Settings Page 9.

SETTINGS		PAGE 9
DHCP: On		
IP: 192.168.0.133		
<<<	Exit	

11. Touch **DHCP:** to open an entry screen to allow you to select the DHCP setting. This setting selects whether the Wi-Fi wireless transmitter will use a Dynamic IP Address assigned by a DHCP server or a Static IP Address manually entered. Consult your network administrator for the proper selection.

Using the numeric keys, enter a new setting, 0 = Off (Static IP) or 1 = On (Dynamic IP), and then press **Save**.

If DHCP:= On (Dynamic IP) is selected,

IP: (Address assigned by DHCP Server)

With **On** selected for the DHCP setting, the IP address assigned by the DHCP server will be shown. Proceed to Steps 12 and 13.

If DHCP:= Off (Static IP) is selected,

IP: (Address is manually entered)

With **Off** selected for the DHCP setting, the IP address is manually entered. Proceed to the instructions on the next page.

12. Press **Exit** to exit Setup and return to the Weight screen.

13. Proceed to the next section of this manual, Configure Wi-Fi Network Module.

Wi-Fi SETUP, CONT.

Enable and Configure Wi-Fi Networking, (DHCP: = Off)

When Off is selected for DHCP:, the IP address will be a static IP address that is assigned by the Network Administrator and manually entered.

1. Touch **IP:** to open an entry screen to enter the IP Address for the scale assigned by the Network Administrator, and then press **Save**.

The format for the IP Address is ### . ### . ### . ### (e.g., 192.168.0.101).

IMPORTANT! No other device on the network should have this IP address.



NOTE: When the setting for **DHCP: = Off** (Static IP), the settings for **NM:** (Netmask) and **GW:** (Gateway Address) will be shown on the touchscreen.

SETTINGS		PAGE 9
DHCP: Off		
IP: 192.168.0.133		
NM: 255.255.255.0		
GW: 192.168.0.1		
<<<	Exit	

The settings for NM: and GW: will be shown if DHCP = Off.

2. Touch **NM:** to open an entry screen to enter the Wi-Fi network Netmask for the network the scale will be connected to, and then press **Save**.

The Netmask of the scale should match the Netmask of the other computers on your network. The format for the Netmask is ### . ### . ### . # (e.g., 255.255.255.0).

3. Touch **GW:** to open an entry screen to enter the Wi-Fi network Gateway Address for the network the scale will be connected to, and then press **Save**.

The format for the Gateway address is # . # . # . # (e.g., 192.168.0.1).

4. Press **Exit** to exit Setup and return to the Weight screen.

5. Proceed to the next section of this manual, Configure Wi-Fi Network Module.

Wi-Fi SETUP, CONT.

Configure Wi-Fi Network Module

Without Wi-Fi credentials, the Wi-Fi module will enter listening mode, in which it functions as a Wi-Fi access point. The SSID of the AP is of the form “REDBIRD_WIFI_XX:XX”, where XX:XX is the last 4 digits of the MAC address. Use a Wi-Fi device, such as a Smartphone, tablet, or laptop to connect to the scale. If the connection fails, try moving the scale to another location or cycling power to the scale.

When the connection has been made, open a web browser, and then go to the location **redbird.com**. The “Configure Wi-Fi” page should appear.



The screenshot shows a mobile browser interface. At the top, the time is 2:54 and there are icons for Bluetooth, Wi-Fi, cellular signal, and battery. The address bar shows the URL redbird.com/?refresh=S. The main content area features the Cardinal DETECTO logo, followed by the heading "Configure Wi-Fi". Below this are three input fields labeled "Network Name", "Password", and "Device Name". A red "Connect" button is positioned below the input fields. Further down, there is a section titled "Available Networks" with a red "Scan" button. Below the scan button is a table with the following data:

SSID	Mac Address	Signal Strength
BLUEROOM	54:75:D0:B3:0D:AF	-51
Dynex617	10:DA:43:82:56:2C	-52

Click on the **Scan** button to see a list of available Wi-Fi networks.

Wi-Fi SETUP, CONT.

Configure Wi-Fi Network Module, Cont.

2:55

redbird.com/?refresh=S

Cardinal
DETECTO

Configure Wi-Fi

Network Name
Dynex617

Password
.....

Device Name
6745 scale

Connect

Available Networks **Scan**

SSID	Mac Address	Signal Strength
BLUEROOM	54:75:D0:B3:0D:AF	-51
Dynex617	10:DA:43:82:56:2C	-52

Enter the Network Name (SSID), Password, and Device Name (optional) for the network you wish to connect to. Note that the Device Name can be anything.

Click on the **Connect** button and the module should try to connect to that network. This may take several seconds. The module will store these network credentials and connect to this network each time the scale is turned on.

Wi-Fi SETUP, CONT.

Changing the Network Credentials

1. With the scale turned on and the Weight screen displayed, press the **Menu** key.
2. The display will change to show the Settings Overview 1 screen.
3. Press **Setup** on the touchscreen.
4. The display will change to show the ENTER PASSCODE screen.
5. Using the 10-key on the touchscreen, enter **64870** and then press **Save**.
6. The display will change to show the Settings Page 1 screen.
7. Press **>>>** to advance to the Settings Page 7 screen.
8. Touch **SSID:** on the touchscreen.
9. You will be prompted to clear the network credentials.

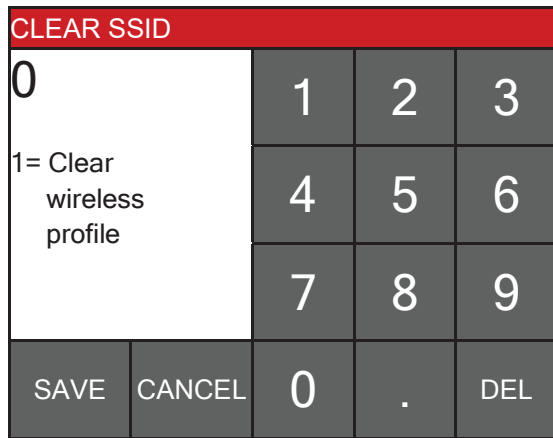

10. Press **1** on the entry screen, and then press **Save** to clear the credentials.
11. Press **Exit** to exit Setup and return to the Weight screen.
12. Repeat the steps in the Configure Wi-Fi Network Module on the previous page to set the new network credentials.

Display the Wi-Fi Network Settings

1. With the scale turned on and the Weight screen displayed, press the **Menu** key.
2. The display will change to show the Settings Overview 1 screen.
3. Press **>>>** to advance to the Settings Overview 2 screen.
4. The scale's Wi-Fi network settings will be shown.
5. Press **Exit** to exit Settings Overview 2 and return to the Weight screen.

You should see the status of the Wi-Fi on the Settings Overview 2 screen. If a scan of Wi-Fi networks shows the "REDBIRD_WIFI_XX:XX" AP, then the module is in listening mode. Refer to the **Configure Wi-Fi Network Module** section for the procedure to set the Wi-Fi credentials.

WIFI OPERATION

Web Server

While the scale is connected to a network you can access the hosted web page. To view the web page, proceed to the IP address of the Redbird module with “/webserver.html” added to it. For example, if the IP address is “192.168.0.5”, enter **192.168.0.5/webserver.html**, and a page like the following should appear.

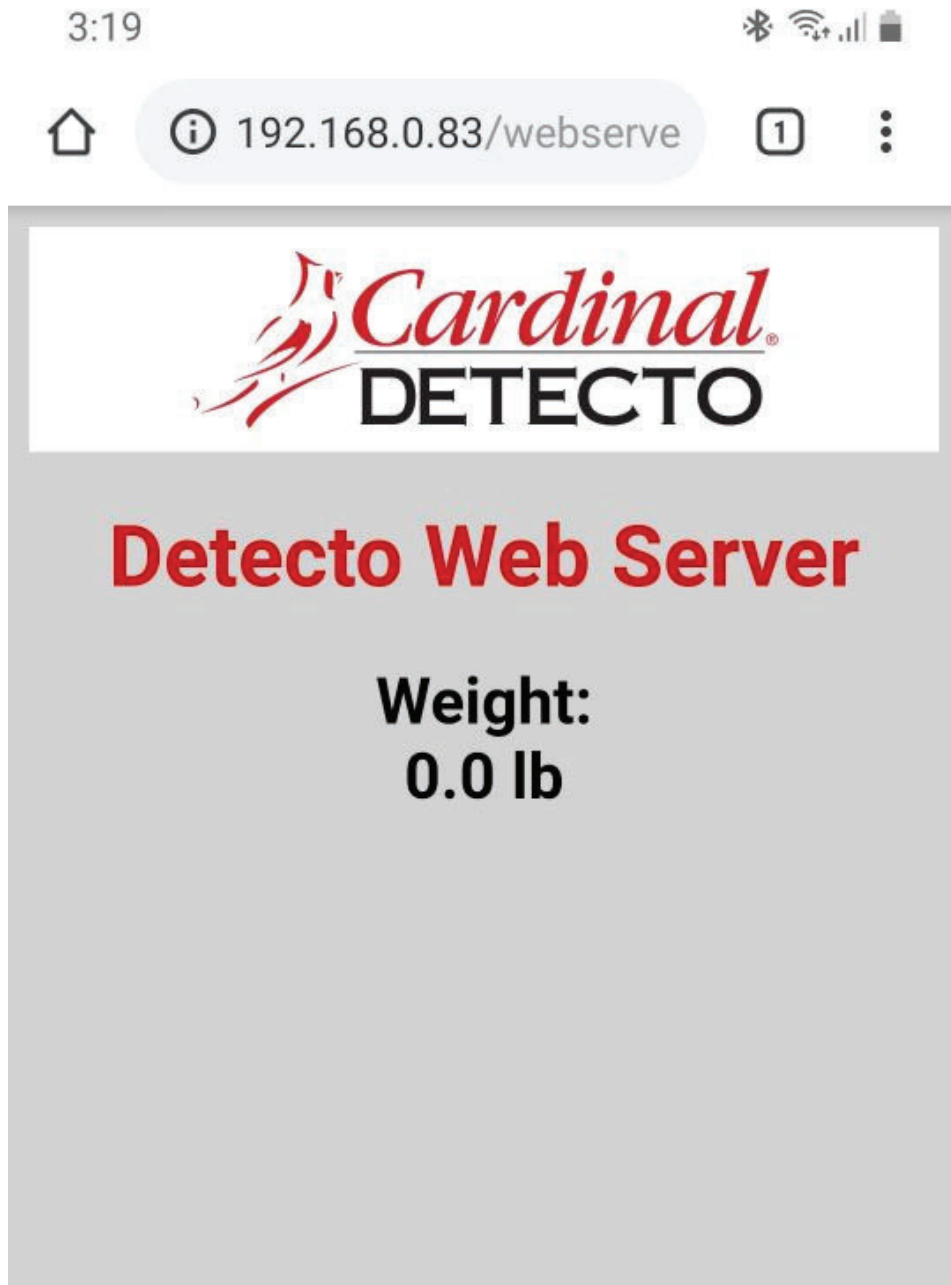

WIFI OPERATION, CONT.

TCP/IP Connection

Continuous output is available by TCP/IP connection to the scale's IP address at port 10001.

- The scale will transmit a single set of weight data each time the SMA weight request <LF>W<CR> is received.
- Each time the SMA weight request <LF>R<CR> is received, the scale will transmit weight data continually until another SMA command is received.

SMA format for both command <LF>W<CR> and <LF>R<CR>.

<LF><s><r><n><m><f><xxxxxx.xxx><uuu><CR>

Where:

LF =	Line feed (hex 0A) = Start of response message
s =	Scale Status definition
	Z = Center of Zero <xxxxxx.xxx>= 0.000
	O = Over Capacity <xxxxxx.xxx>= +weight
	U = Under Capacity <xxxxxx.xxx>= -weight
	E = Zero Error (clears when the condition clears)
	<space> = None of the above conditions NOTE: For "E" error condition <xxxxxx.xxx>= _____ (center dashes) and "Z", "O", "U" is overridden
r =	Range ("1", "2", "3", etc.) always "1" for a single range
n =	Mode of Operation (Gross/Net status)
	G = Gross normal weight
	T = Tare weight (in response to "M" command)
	N = Net normal weight
	g = gross weight in high-resolution
	n = net weight in high-resolution
m =	Motion status
	M = Scale in Motion
	<space> = Scale not in Motion
f =	Future = Reserved for future or custom use
xxxxxx.xxx =	Weight with a decimal point if necessary
uuu =	Units = e.g., lb, kg
CR =	Carriage Return (hex 0D) = End of response message

SMA Commands

Once a TCP/IP connection has been made to the scale, you can issue SMA commands to it. The scale will respond to the SMA commands in the format shown in the Response column of the Wi-Fi AND BLUETOOTH SMA COMMANDS table in this manual.

BLUETOOTH LOW ENERGY (BLE)

The DETECTO 6745 Scale has a wireless transmitter inside the scale weight indicator that can be configured for Bluetooth Low Energy (BLE). When possible, BLE standard specifications are used (those that are adopted by the Bluetooth SIG). Custom services were created to request indicator and scale information whose communication protocol was developed by the Scale Manufacturers Association (SMA).

Features Available with BLE

- Device Information Service
 - Manufacturer Name
 - Model Number
 - Software Revision
- Battery Service
 - Battery Level Percentage
- Weight Scale Service
 - Weight Measurement
 - Weight Scale Feature
- Custom Services
 - DETECTO SMA Service

Enable Bluetooth (BLE) Networking

NOTE: Default Network Settings are Bluetooth: Off, Wi-Fi: Off, and DHCP: On.

1. With the scale turned on and the Weight screen displayed, press the **Menu** key.
2. The display will change to show the Settings Overview 1 screen.

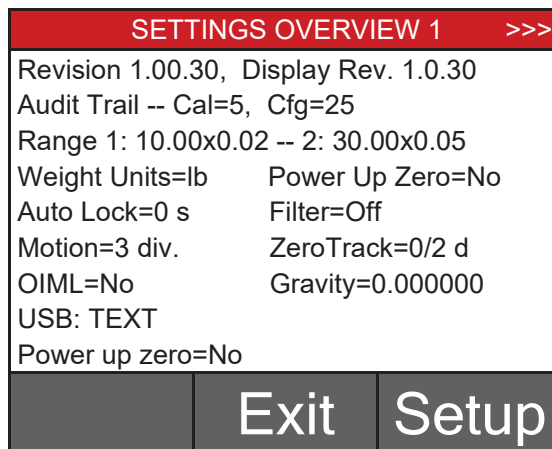

3. Press **Setup** on the touchscreen.

BLUETOOTH LOW ENERGY (BLE), CONT.

Enable Bluetooth (BLE) Networking, Cont.

4. The display will change to show the ENTER PASSCODE screen.

ENTER PASSCODE				
Enter passcode to access settings. Press CANCEL to exit.	1	2	3	
	4	5	6	
	7	8	9	
SAVE	CANCEL	0	.	DEL

5. Using the 10-key on the touchscreen, enter **64870**, and then press **Save**.

6. The display will change to show the Settings Page 1 screen.

SETTINGS	PAGE 1
Model: 6745	
Date: 7/30/2024	
Time: 10:24:44	
Language: English	
<<<	Exit >>>

7. Press >>> to advance to the Settings Page 7 screen.

SETTINGS	PAGE 7
Bluetooth: Off	
Wi-Fi: Off	
Extend Weight: No	
<<<	Exit >>>

BLUETOOTH LOW ENERGY (BLE), CONT.

Enable Bluetooth (BLE) Networking, Cont.

8. Touch **Bluetooth**: to open a selection screen to turn the Bluetooth wireless transmitter “On”. Press 1 on the entry screen, and then press **Save**.

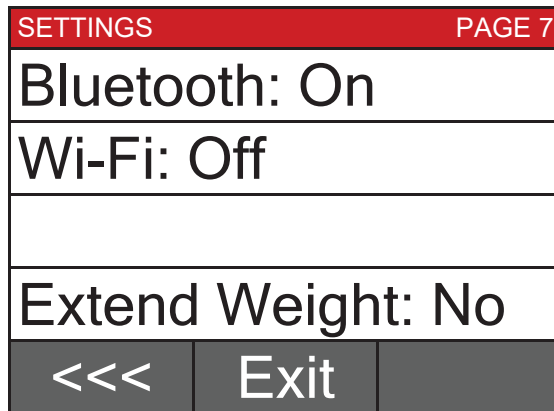

9. Press **Exit** to exit Setup and return to the Weight screen.
10. The scale is now ready to pair with a Bluetooth-capable device.

BLUETOOTH LOW ENERGY (BLE), CONT.

Enable Bluetooth (BLE) Networking, Cont.



IMPORTANT! If an attempt is made to turn Bluetooth (BLE) off when a device is connected to the scale, the display will show the error message Error - BLE Off.

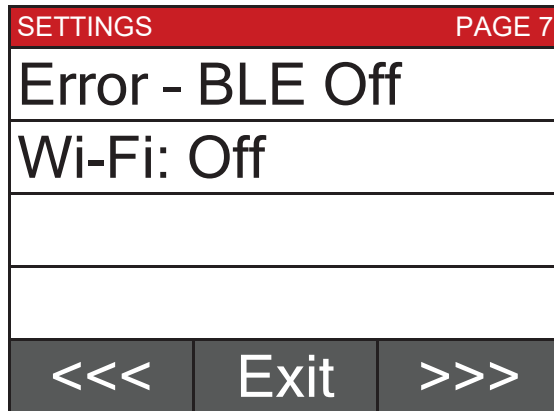

This message will be shown until <<< or >>> are pressed to change to a different settings page, **Exit** is pressed to return to the Weight screen, or the error message Error - BLE Off is touched, and then **CANCEL** is selected on the Bluetooth selection screen.

Note that at this time, Bluetooth (BLE) is still on, only the message has been cleared.

To turn Bluetooth (BLE) off, the device must be disconnected from the scale or the scale must be turned “Off” and back “On”.

Bluetooth Pairing

To pair a Bluetooth-capable device with the scale, select the name of the scale from the list of available connections: 6745 Scale XX:XX:XX:XX:XX:XX. Note that the X’s represents the MAC address of the BLE wireless transmitter in the scale’s weight indicator.

NOTE: If there are multiple 6745 scales nearby, perform the steps below to proceed to the Settings Overview 2 page to view the scale’s Bluetooth Advertisement name (BLE Adv:).

BLE Adv: 6745 Scale XX:XX:XX:XX:XX:XX

1. With the scale turned on and the Weight screen displayed, press the **Menu** key.
2. The display will change to show the Settings Overview 1 screen.
3. Press >>> to advance to the Settings Overview 2 screen.
4. The scale’s Bluetooth setting and Bluetooth Advertisement name will be shown.
5. Press **Exit** to exit Settings Overview 2 and return to the Weight screen.

When a stable reading is achieved, and if the scale is paired with a Bluetooth-capable device, the reading will transmit when the device sends a request to receive data.

BLUETOOTH LOW ENERGY (BLE), CONT.

INTERFACING TO BLE

Note: 16-bit (4-digit) UUID's are adopted standards. 128-bit (32-digit) UUIDs are custom services or characteristics.

Standard Services per Bluetooth SIG

Reference adopted specifications at <https://www.bluetooth.com/specifications/gatt>

Device Information Service (0X180A)

Characteristics	Number	Value(s)	Attributes
Manufacturer Name String	0x2A29	"Detecto"	READ
Model Number String	0x2A24	"6745"	READ
Software Revision String	0x2A28	"1.0.XX" software of scale	READ

Battery Service (0x180F)

Characteristics	Number	Value(s)	Attributes
Battery Level	0x180F	0x00 – 0x64 (uint16), represents 0 – 100 percent	READ

Weight Scale Service (0X181D)

Characteristics	Number	Value(s)	Attributes
Weight Measurement	0x2A9D	<p><8bit Flag><uint16 weight><uint16 bmi><uint16 ht></p> <p>Supported Flags:</p> <p>Flag bit0: 0 = SI, 1 = Imperial</p> <p>bit3: 0 = BMI and Height not present 1 = BMI and Height present</p> <p>bit4: 0 = Not below zero* 1 = Below zero*</p> <p>SI: Wt is KG with resolution 0.0005</p> <p>Imperial: Wt is lb with a resolution of 0.01</p>	READ INDICATE
Weight Scale Feature	0x2A9E	NOT YET IMPLEMENTED	

- * • If the weight is below zero (0), the weight you will see is zero (0).
- If the weight is below zero (0), bit 4 of Weight Measurement will be set to 1, otherwise, bit 4 is set to zero (0).

NOTE: The maximum weight value displayed is 655.35 in both pounds (lb) and kilograms (kg).

BLUETOOTH INTERFACE STANDARD PROTOCOLS

Bluetooth Characteristic – Weight_Measurement: 0x2A9D

Widely accepted BLE GATT profiles are used to transmit data to other devices/software that have implemented these profiles. Data is passed via BLE using the GATT characteristic “Weight Measurement” (0x2A9D) as defined by Bluetooth SIG. Refer to the data table below about Weight Measurement Characteristics.

Weight_Measurement: 0x2A9D

NAMES	FIELD REQUIREMENTS	FORMAT	MIN. VALUE	MAX. VALUE	ADDITIONAL INFORMATION								
					BIT FIELD								
				Bit	Size	Name	Definition						
						Key	Value	Requires					
Flags	Mandatory	8 bit	N/A	N/A	0	1	Measurement Units	0	SI (Weight and Mass in Units of Kilogram (kg) and Height in Units of Meter)	C1			
								1	Imperial (Weight and Mass in Units of Pound (lb) and Height in Units of inch (in))	C2			
							1	1	Time Stamp Present	0	False		
										1	True	C3	
							2	1	User ID Present	0	False		
										1	True	C4	
							3	1	BMI and Height Present	0	False		
										1	True	C5	
4	1	Below Zero	0	Not Below Zero									
			1	Below Zero									
Weight - SI	C1	uint16	N/A	N/A	Information: Unit is in kilograms with a resolution of 0.005 and is determined when bit 0 of the Flags field is set to 0. Unit: org.bluetooth.unit.mass.kilogram Exponent: Decimal, -3 Multiplier: 5								
Weight - Imperial	C2	uint16	N/A	N/A	Information: Unit is in pounds with a resolution of 0.01 and is determined when bit 0 of the Flags field is set to 1. Unit: org.bluetooth.unit.mass.pound Exponent: Decimal, 02.								
Time Stamp	C3		N/A	N/A	Information: Smallest unit in seconds Unit: org.bluetooth.characteristic.date.time								
User ID	C4	uint8	N/A	N/A	The special value of 0xFF (255 Decimal) for User ID represents "unknown user". Information: Unit is unitless with a resolution of 1 <table border="1" style="width: 100%; border-collapse: collapse;"> <thead> <tr> <th>Key</th> <th>Value</th> </tr> </thead> <tbody> <tr> <td>255</td> <td>Unknown user</td> </tr> </tbody> </table> Unit: org.bluetooth.unit.unitless Exponent: Decimal, 0					Key	Value	255	Unknown user
Key	Value												
255	Unknown user												
BMI	C5	uint16	N/A	N/A	Information: Unit is unitless with a resolution of 0.1 Unit: org.bluetooth.unit.unitless Exponent: Decimal, -1								
Height - SI	C1 C5	uint16	N/A	N/A	Information: Unit is in meters with a resolution of 0.001 and is determined when bit 0 of the Flags field is set to 0. Unit: org.bluetooth.unit.length.meter Exponent: Decimal, -3								
Height - Imperial	C2 C5	uint16	N/A	N/A	Information: Unit is in inches with a resolution of 0.1 and is determined when bit 0 of the Flags field is set to 1. Unit: org.bluetooth.unit.length.inch Exponent: Decimal, 0-1								

BLUETOOTH INTERFACE STANDARD PROTOCOLS, CONT.

Custom Services

DETECTO SMA Service (0X907A0000-8699-47DD-AB30-D7AAD5F83E54)

All custom characteristics have the same base number of the Service UUID 0x907aXXXX-8699-47dd-ab30-d7aad5f83e54 where the XXXX part distinguishes the service.

Characteristics	Sub Number	Value(s)	Attributes
Rx Cmd	0001	SMA string received by scale (up to 20 chars)	WRITE
Tx Cmd	0002	SMA string sent by scale (up to 20 chars)	NOTIFY

SMA Commands

The SMA commands shown in the Wi-Fi AND BLUETOOTH SMA COMMANDS table on pages 55 and 56 of this manual can be sent using the DETECTO SMA Service's Rx Cmd characteristic (0x907a0001-8699-47dd-ab30-d7aad5f83e54).

Responses will put out a notification on the Tx Cmd characteristic (0x907a0002-8699-47dd-ab30-d7aad5f83e54).

Wi-Fi AND BLUETOOTH SMA COMMANDS

The format used to send SMA commands to the scale is:

<LF>command<CR>

Where “command” is the ASCII letter(s), or the Hex Rep. listed in the table below. For example, <LF>Z<CR> or 0A5A0D would send the command to zero the scale. Note that the response of each command is listed under the Response column of the table.



Any invalid command sent will return a *question mark* for a response. For example, sending a <LF>XZ<CR> will return 0A 3F 0D (<LF>?<CR>).

Command	Hex Rep.	Response
Z – zero scale	0A5A0D	None. You should see scale zero itself.
D – scale diagnostics	0A440D	0A 20 20 20 20 0D = means there are no errors, EEPROM error will show an E in the second space and C will show in the third space if there is a calibration error. 20 = SPACE
W – request weight	0A570D	0A 5A 31 47 20 20 30 30 30 30 30 2E 30 30 6C 62 0D = Z1G 000000.00lb
H – request high-resolution weight	0A480D	0A 5A 31 67 20 20 30 30 30 30 30 2E 30 31 6C 62 0D = Z1g 000000.01lb
A – about scale first line	0A410D	0A 53 4D 41 3A 32 2F 31 2E 31 0D = SMA:2/1.1
B – about scale scroll	0A420D	Each time sent you will get the next line of information until there is no longer any information. 1. 0A 4D 46 47 3A 44 65 74 65 63 74 6F 0D = MFG:Detecto 2. 0A 4D 46 44 3A 41 70 65 78 0D = MOD:6745 3. 0A 52 45 56 3A 31 2E 30 2E 31 34 0D = REV:X.X.XX 5. 0A 45 4E 44 3A 0D = END: 6. If B is sent again you will get the unknown command response until the A command is sent again. 0A 3F 0D = ?
I – scale information	0A490D	0A 53 4D 41 3A 32 2F 31 2E 31 0D = SMA:2/1.1

Wi-Fi AND BLUETOOTH SMA COMMANDS, CONT.

Command	Hex Rep.	Response
N – scale information scroll	0A4E0D	<p>Each time sent you will get the next line of scale information until there is no longer any information.</p> <p>1. 0A 54 59 50 3A 53 0D = TYP:S</p> <p>2. 0A 43 41 50 3A 20 6C 62 3A 36 30 30 2E 30 3A 32 3A 31 0D = CAP: lb:600.0:2:1, this depends on the settings of the lcon. 600.0 – Capacity, 2 – Interval, & 1 – Decimal</p> <p>3. 0A 43 4D 44 3A 48 52 49 4E 58 0D = CMD: HRINX</p> <p>4. 0A 45 4E 44 3A 0D = END:</p> <p>5. If N is sent again you will get the unknown command response until the I command is sent again. 0A 3F 0D = ?</p>
R – repeat displayed weight continuously	0A520D	<p>0A 5A 31 47 20 20 30 30 30 30 30 2E 30 30 6C 62 0D = Z1G 000000.00lb, you should get this continuously until another SMA command is received.</p>
XB – battery level percentage	0A58420D	<p>0A 38 36 2E 32 35 0D = 86.25</p>

DISPLAY SCALE Wi-Fi AND BLUETOOTH SETTINGS

To View the Settings:

1. Press the  key to turn the scale on.
2. The scale will show the DETECTO logo briefly and then change to the Weight screen.
3. With the Weight screen displayed, press the **Menu** key.
4. The display will change to show the Settings Overview 1 screen.

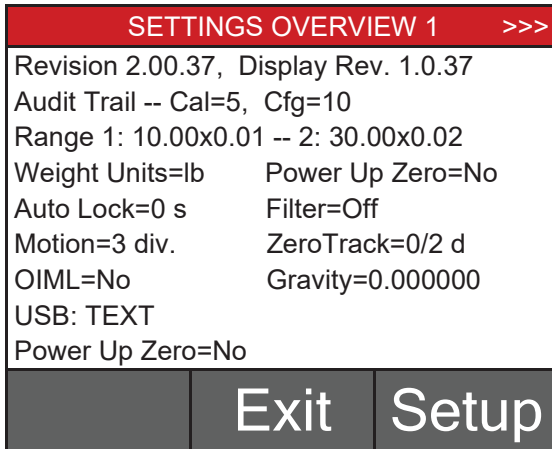

5. Press >>> on the touchscreen to advance to the Settings Overview 2 screen.

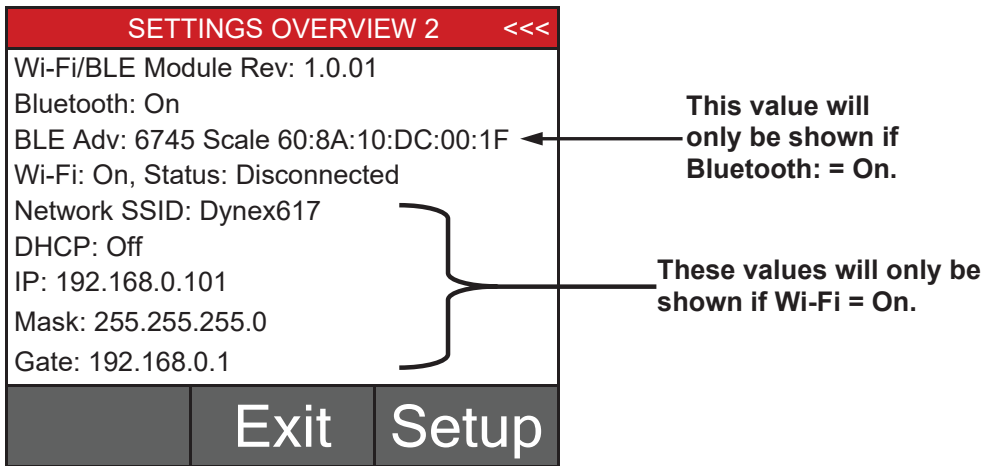

6. Press **Exit** to exit the Settings Overview screen and return to the Weight screen.

ERROR AND OPERATION MESSAGES

The DETECTO 6745 Scale is equipped with diagnostic software that tests various portions of the scale's circuitry and verifies proper operation. Should a problem be detected, an error or status message will be displayed. The following lists these messages and their meaning.

AUTO LOCKED

This message appears if the weight has been automatically locked.

BELOW ZERO

The scale weight reading is below zero.

CAL REQUIRED

The indicator requires calibration. Weight will show as dashes. Consult your scale service representative.

CENTER ZERO

The scale weight reading is at the center of zero.

ERROR CAN NOT ZERO

The scale cannot be zeroed due to motion on the scale.

LOCKED

This message appears if the weight has been manually locked.

MOTION

The scale is in motion based on the motion range setting.

OVERCAPACITY

The scale weight exceeds the scale capacity.

OVERFLOW ERROR

This message appears if there are too many characters to display on the screen.

BEFORE YOU CALL FOR SERVICE

Your scale has been designed to provide you with years of trouble-free operation. Despite this, troubles sometimes happen. Before calling for service assistance you should make some initial checks to verify that a problem does exist. The following describes several types of symptoms along with suggested remedies.

Problem	Possible Solutions
The display does not turn on	<p><u>AC Operation:</u></p> <p>Is the AC power cord fully inserted into the wall receptacle? Check the wall receptacle for proper AC power. Try another electrical appliance in the same receptacle, does it work? Check the circuit breaker. Has there been a power failure?</p> <p><u>Battery operation:</u></p> <p>Check if the batteries are installed correctly. Are batteries discharged? Replace if Alkaline or recharge if NI-CAD or NiMH.</p>
Incorrect weight displayed	<p>Ensure that the baby tray is not touching an adjacent object. Have proper operation procedures been followed?</p>
The scale will not display the weight	<p>Refer to the Error and Status Display section and make certain that the <i>-OERRP-</i> message is not displayed. If so, and the scale is not loaded, consult your scale service representative.</p>

CARE AND CLEANING



NOTE: The DETECTO 6745 Scale contains no user-serviceable parts and maintenance should be limited to cleaning it thoroughly on a routine basis and battery replacement as required.

- Always remove the power before cleaning.
- DO NOT pour or spray water or a liquid cleaner directly on the indicator to clean it. The indicator is not waterproof and covering it with water or a liquid cleaner will damage it and void the warranty.
- DO NOT use wire brushes, abrasives, or cleaning tools such as steel pads and scrapers, which will scratch the surface. Instead, use soft cloths or plastic scouring pads for cleaning.
- DO clean the indicator with a damp soft cloth and mild non-abrasive detergent.
- When possible, use treated water. Hard water can leave behind deposits. Soft water is much gentler on the indicators and painted steel surface.
- Avoid the use of acetone, thinner or other volatile solvents, and abrasive-type cleaners for cleaning. If required, a mild solvent such as mineral spirits can be used to remove oil, grease, tars, wax, and similar substances. Use a cloth dampened with mineral spirits and apply only to contaminated areas. Follow up the use of this mild solvent with detergent cleaning and rinsing.

PRINTER OUTPUT

The DETECTO 6745 Digital Baby Scale has an RS-232 serial port that may be connected to an optional printer to record weight. The output connector is located on the rear panel. Refer to the figure below.

When the weight display is locked on the baby's weight and the Weight Lock annunciator is turned on, the weight data may be transmitted by pressing the **ENTER** key. **NOTE:** If the threshold feature was enabled during setup and calibration, with a printer attached to the scale, the weight data will automatically print when the weight reading of the baby has been Auto Locked.

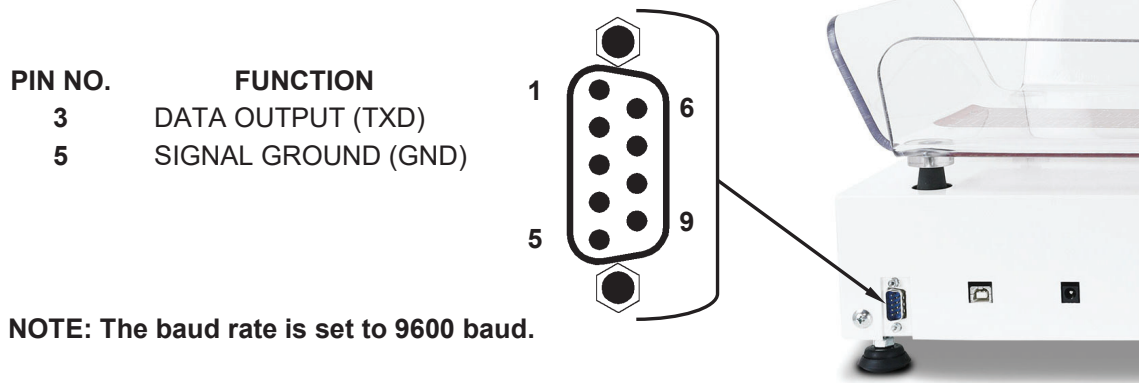

An example of the RS232 serial output format is:

```
GROSS: 30.168 lb[CR][LF][LF][LF][LF][LF][LF][LF][LF]
```

PARTS IDENTIFICATION

Final Assembly Parts List

ITEM	QTY	PART NUMBER	DESCRIPTION
1	1	593GR986	SERIAL TAG ASSY
2	1	593R1007	FACTORY SET LABEL
3	1	3300-0480-0A	SUB-ASSY, DISPLAY, 6745
4	1	6021-1032	SCW, THUMB, MACHINE-SCW, 06-32 X 0.250
5	4	6021-1058	SCW, TRUSS-HEAD MACHINE-SCW, 10-32 X 0.375
6	1	6021-1103	SCW, HALF-DOG SET-SCREW, 08-32 X 0.50
7	2	6021-1293	SCW, FLAT-HEAD THREAD CUTTING, TYPE 25, #4-24 X 5/16, PHIL. DR. Z-PLATE
8	4	6024-0049	WASHER LOCK, EXT TOOTH, #10 TYPE A, Z-PL
9	2	6540-1236	HANDLE, SNAP-IN RECESSED PULL HANDLE, BLACK
10	4	8529-B215-08	SUPPORT, TRAY
11	1	8535-0240-08	ICON MOUNTING STRAP
12	1	8535-0255-0A	BASE ASSEMBLY - 6745
13	1	8535-B065-08	WARNING LABEL - BABY SCALE
14	1	8535-0235-18	COVER, PRINTED
15	1	8555-B166-08	BATTERY COVER: 6745

Final Assembly – Display (A to A) and Side View

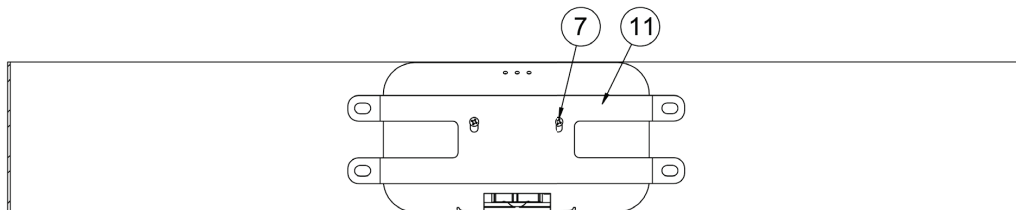

SECTION A-A

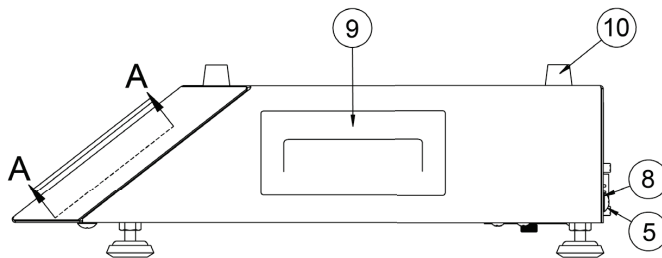

PARTS IDENTIFICATION, CONT.

Final Assembly – Front and Bottom View

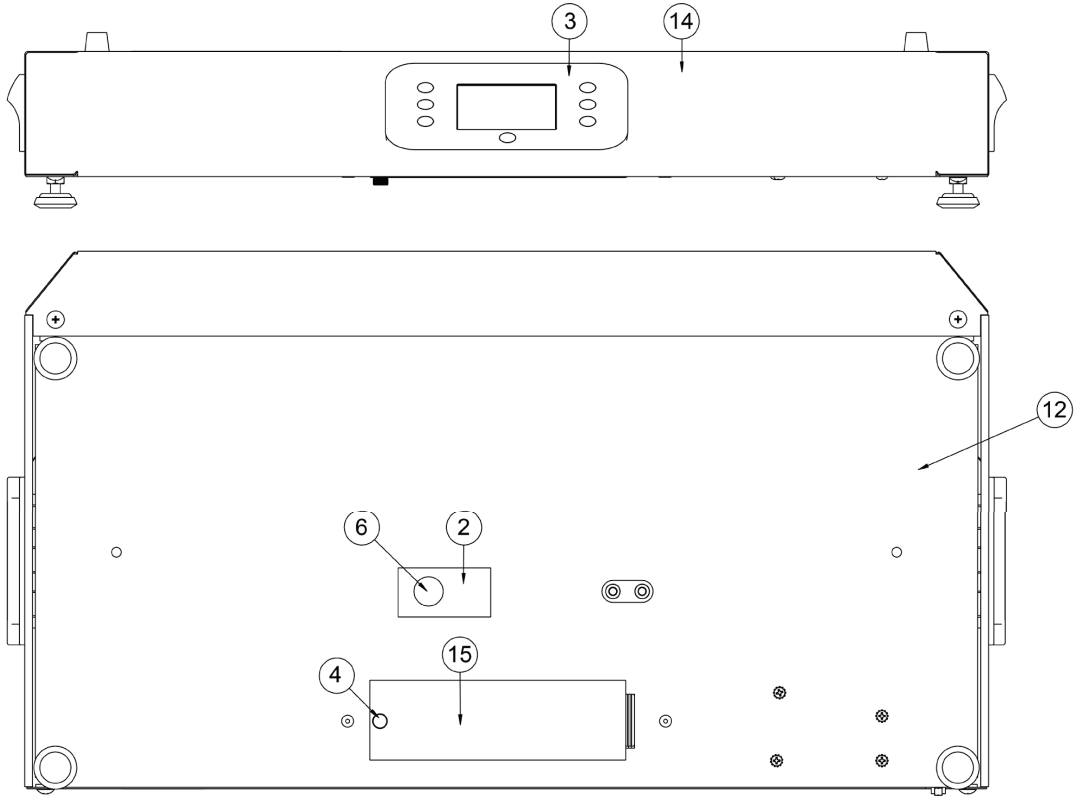

Final Assembly – Back and Top View

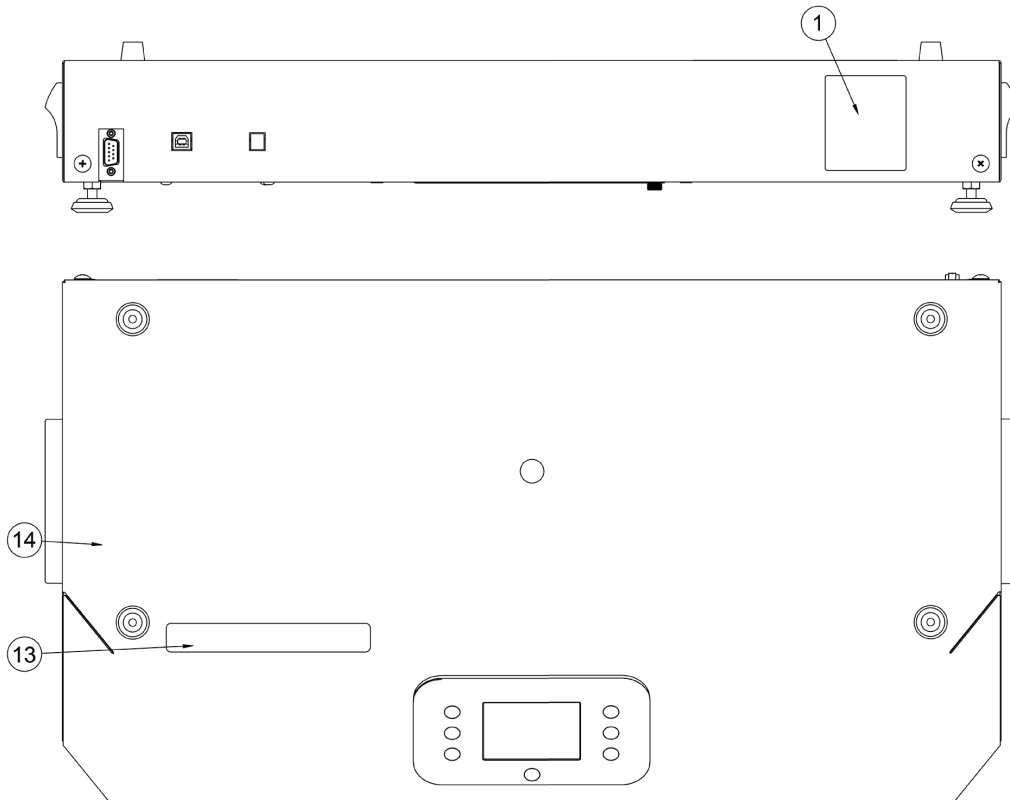

PARTS IDENTIFICATION, CONT.

Baby Tray Assembly

ITEM	QTY	PART NUMBER	DESCRIPTION
1	1	8535-0242-0A	BABY SCALE TRAY

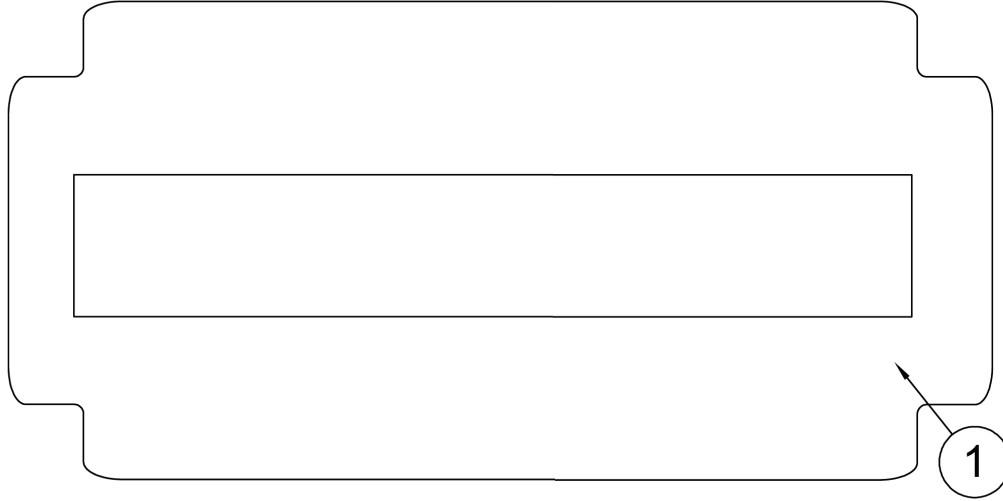

STATEMENT OF LIMITED WARRANTY

DETECTO warrants its equipment to be free from defects in material and workmanship as follows: DETECTO warrants to the original purchaser only that it will repair or replace any part of equipment which is defective in material or workmanship for a period of **two (2) years from date of shipment**. Detecto shall be the sole judge of what constitutes a defect.

During the **first ninety (90) days** DETECTO may choose to replace the product at no charge to the buyer upon inspection of the returned item.

After the first ninety (90) days, upon inspection of the returned item, DETECTO will repair or replace it with a remanufactured product. The customer is responsible for paying for the freight both ways.

This warranty does not apply to peripheral equipment not manufactured by DETECTO; this equipment will be covered by certain manufacturer's warranty only.

This warranty does not include replacement of expendable or consumable parts. This does not apply to any item which has deteriorated or damaged due to wear, accident, misuse, abuse, improper line voltage, overloading, theft, lightning, fire, water or acts of God, or due to extended storage or exposure while in purchaser's possession. This warranty does not apply to maintenance service. Purchased parts will have a ninety (90) day repair or replacement warranty only.

DETECTO may require the product to be returned to the factory; item(s) must be properly packed and shipping charges prepaid. A return authorization number must be obtained for all returns and marked on the outside of all returned packages. DETECTO accepts no responsibility for items lost or damaged in transit.

Conditions Which Void Limited Warranty

This warranty shall not apply to equipment which:

- A.) Has been tampered with, defaced, mishandled or has had repairs and modifications not authorized by DETECTO.
- B.) Has had serial number altered, defaced, or removed.
- C.) Has not been properly grounded according to Detecto's recommended procedure.

Freight Carrier Damage

Claims for equipment damaged in transit must be referred to the freight carrier in accordance with freight carrier regulations.

This warranty sets forth the extent of our liability for breach of any warranty or deficiency in connection with the sale or use of the product. DETECTO will not be liable for consequential damages of any nature, including but not limited to, loss of profit, delays or expenses, whether based on tort or contract. Detecto reserves the right to incorporate improvements in material and design without notice and is not obligated to incorporate improvements in equipment previously manufactured.

The foregoing is in lieu of all other warranties, express or implied including any warranty that extends beyond the description of the product including any warranty of merchantability or fitness for a particular purpose. This warranty covers only those DETECTO products installed in the forty-eight (48) contiguous continental United States.



Ph. (800) 641-2008
E-mail: detecto@cardet.com
102 E. Daugherty
Webb City, MO 64870

04/22/2024
Printed in USA
D268-WARRANTY-DET-B



DETECTO
102 E. Daugherty, Webb City, MO 64870 USA
Ph: 417-673-4631 or 1-800-641-2008
Fax: 417-673-2153
www.Detecto.com
Technical Support: 1-866-254-8261
E-mail: tech@cardet.com

Printed in USA

8535-0251-0M Rev A 08/24