

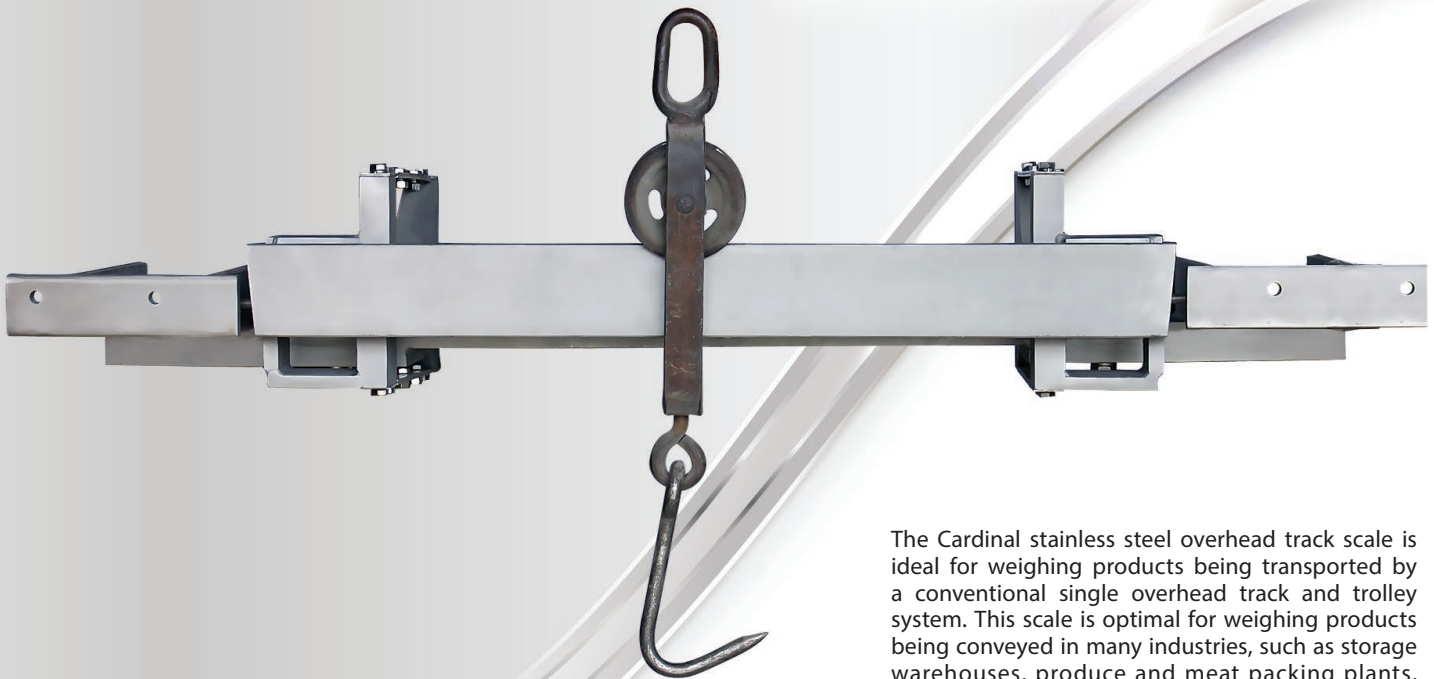

CARDINAL®

AB-4

STAINLESS STEEL ELECTRONIC OVERHEAD TRACK SCALE



- All Stainless Steel
- 2,000-lb Capacity
- Three Track Lengths
- Weight Indicator Included

The Cardinal stainless steel overhead track scale is ideal for weighing products being transported by a conventional single overhead track and trolley system. This scale is optimal for weighing products being conveyed in many industries, such as storage warehouses, produce and meat packing plants, or any manufacturing process using this type of conveying system.

Cardinal's overhead track scale is available with your choice of three rail lengths – 24 in, 30 in, and 50 in – making it easily adaptable to most any rail hanger spacing. Its rugged construction ensures years of continuous, trouble-free use. Non-corrosive stainless steel material provides for easy cleaning and washdown.

Cardinal's "solid-mount" load cell assembly virtually eliminates all moving parts that may wear and need replacement under heavy use. Installation is as easy as it is to use. Simply cut your existing rail and mount the scale with four bolts. That easy – that quick.

ELECTRONIC TRACK SCALE SPEEDS UP YOUR OPERATION

The Cardinal electronic overhead track scale is equipped with the 205 digital weight indicator, which provides quick, responsive weight readouts of the commodities rolled on the scale. The 0.6-in-high LED display and stainless steel washdown enclosure are ideal for various overhead track systems in harsh manufacturing environments.



205 Digital Weight Indicator

205 INDICATOR (Included with the scale)

Dimensions	9.2 in W x 7.5 in H x 3.1 in D / 233.0 mm W x 191.0 mm H x 79.0 mm D
Enclosure	Stainless steel washdown, wall or desk mount
Display	Six-digit, seven-segment, 0.6-in (15-mm) high LED
Keypad	Color-coded membrane type, 7 keys
Operating Environment	Operating Temperature Range: -10 to 122 °F (-23 to 50 °C) Humidity: 90% non-condensing (maximum)
Internal Resolution	1 part in 16,777,216
Power	100 to 240 VAC (50/60 Hz) at 0.4A maximum
Tare Capacity	Scale Capacity

AB-4 STAINLESS STEEL ELECTRONIC OVERHEAD TRACK SCALE

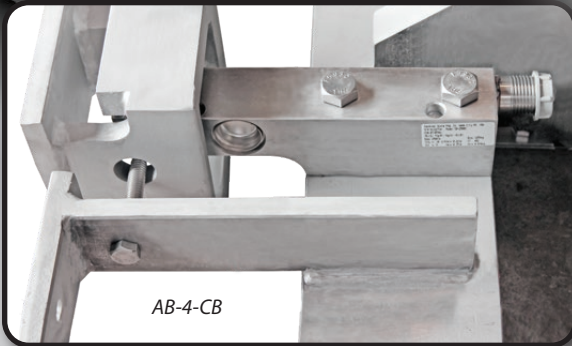

AB-4-CB

Utilizes Cardinal Scale's SB series stainless steel load cells.

	Model Number (Rail Size)	Overall Assembly A	Assembly Framework B	Weighrail Length C	Customers' Rail Cutout D
Dimensions	AB-4-CA (24-in rail)	40.3 in / 102.4 cm	36.5 in / 92.7 cm	24.0 in / 61.0 cm	24.2 in / 61.5 cm
	AB-4-CB (30-in rail)	46.3 in / 117.6 cm	42.5 in / 108.0 cm	30.0 in / 76.2 cm	30.2 in / 76.7 cm
	AB-4-CC (50-in rail)	66.3 in / 168.4 cm	62.5 in / 158.8 cm	50.0 in / 127.0 cm	50.2 in / 127.5 cm
Capacity		2,000 lb / 1,200 kg			
Graduations		0.5 lb / 0.2 kg			
Construction		Stainless Steel			
Operating Temperature		32.5°F - 122.5°F, 0.5°C - 50.5°C			

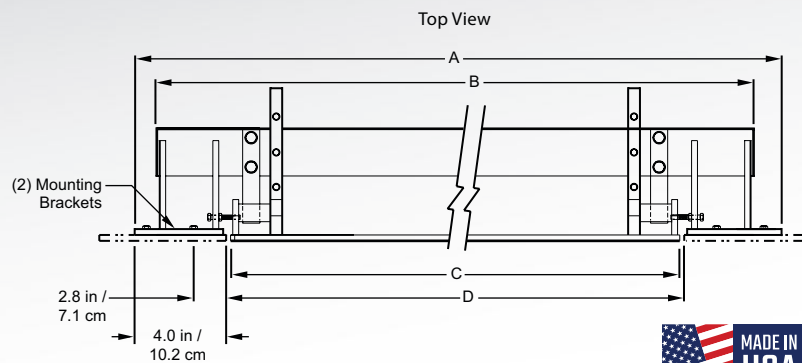
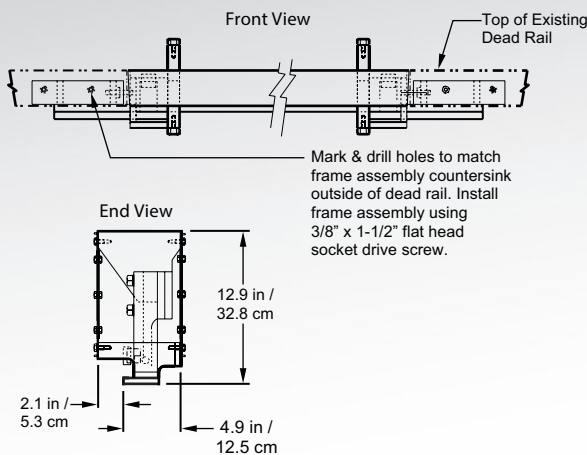

Cardinal Scale reserves the right to improve, enhance, or modify features and specifications without prior notice.



102 East Daugherty St., Webb City, MO 64870 USA
Toll-Free: (800) 441-4237 E-mail: cardinal@cardet.com
www.CardinalScale.com

SOLD BY: