



COST JUSTIFICATION GUIDE

ARMOR[®]
DIGITAL TRUCK
SCALES



CARDINAL[®]

QUESTIONS TO CONSIDER



QUESTIONS TO CONSIDER BEFORE PURCHASING A TRUCK SCALE

Reasons Why Cardinal's ARMOR® Digital Truck Scale Provides the Best Return on Investment

Cardinal Scale's all-around innovative truck scale and load cell design provides the most protection against circumstances—seen and unforeseen. The combination of Cardinal Scale's SmartCell® load cells, ARMOR® weighbridge, and axis® frictionless centering system provide a well-rounded vehicle scale package that protects against the harshest conditions while transmitting valuable weight data digitally. Cardinal Scale provides customers with the versatility and efficiency required to fit their individual scale needs while saving valuable time and effort.

Cardinal Scale engineers, develops, and manufactures their truck scale hardware, software, and load cell technology in one location. Weighbridges, indicators, load cells, and related instrumentation are produced to meet the individual customer's needs. Due to the highly-vertically-integrated nature of Cardinal Scale's manufacturing processes, the company can easily modify and customize each truck scale they make to fit a customer's application—a benefit that is becoming increasingly rare in today's truck scale market.

Keeping with its visionary heritage, Cardinal Scale has again pushed the boundaries of truck scale technology by developing SmartCell® digital load cells. The added benefit of transmitting weight digitally is greatly augmented by Cardinal Scale's iSite remote monitoring system. Dealers can now see, in real time, load cell issues as they happen. Most importantly, time spent checking load cell wiring is greatly reduced thanks to the streamlined, digital load cell diagnostics. Dealers can now quickly and remotely diagnose load cell issues and replace defective load cell elements in a fraction of what analog load cell diagnosis requires.

Carefully consider the following questions for the purchase of a truck scale to see if Cardinal's ARMOR® digital truck scales will provide the best solution for your time and resource investment.

TABLE OF CONTENTS	PAGE
Questions to Consider Before Purchasing a Truck Scale	1
1. Have You Factored in the Cost of Downtime? Are Scale Disruptions a Regular Part of Your Truck Scale Ownership Experience?	2
2. Would You Like to Have the Capability of Remotely Monitoring Your Customer's Truck Scale to Diagnose Load Cell Issues?	3
3. Is Your Truck Scale Application Subject to Extreme Temperatures?	4
4. Is Your Truck Scale Subject to Damage from Dirt, Grit, and Grime? Are Your Load Cells Exposed to Water?	5
5. Does it Take You a Long Time to Change Out Load Cells?	6
6. Are Lightning Strikes and Power Surges an Issue for Your Truck Scale?	7
7. Do You Frequently Suffer from Data Transmission Errors? Do Your Analog Load Cells Recurrently Send Incorrect or Misleading Readings?	8
Armor® Cost Justification Factors	9
Conclusion	10



COST OF DOWNTIME

1. HAVE YOU FACTORED IN THE COST OF DOWNTIME? ARE SCALE DISRUPTIONS A REGULAR PART OF YOUR TRUCK SCALE OWNERSHIP EXPERIENCE?

SmartCell® load cells and iSite software greatly reduce the monetary risks involved in scale ownership.

- Most truck scale manufacturers still offer electronic scales that feature analog load cells. Analog load cells require time-consuming wiring and load cell fault diagnosis. Analog load cells are also much more prone to fluctuations in temperature and wiring degradation and damage due to moisture and sediment. Cardinal's SmartCell® digital load cells feature stainless steel double-ended shear beam bodies and patent-pending complete internal encapsulation via proprietary potting methods to protect internal circuitry. SmartCell® load cells are daisy-chained together by waterproof load cell cables and there is no junction box that is susceptible to water and lightning damage. SmartCells can be remotely monitored through Cardinal's cloud-based iSite portal so dealers can be alerted to a load cell malfunction. Time spent having to randomly diagnose wiring failures is eliminated, and costs associated with lengthy diagnosis periods are also minimized.
- Since the circuitry of the load cell is internal, wiring is not openly exposed to corrosion. The internal wiring and digital components are completely protected by Cardinal's proprietary potting compound process that fills all of the internal voids of the load cell. This load cell technology prevents ingress from moisture and provides the SmartCell® with an IP69K rating. Load cell failures associated with exposure to water and electrical surges are greatly reduced and load cell replacements become much less frequent due to SmartCell® technology.
- In the event that there is damage to the load cell, it can be easily swapped out and replaced quickly. Simply removing a few bolts and two screw-on cell cables is all that is needed. Technicians of any level can complete such a simple task, and your scale can be back to running in a fraction of the time—increasing profits. Electronic truck scales with analog load cells still rely on time-intensive traditional wiring methods that can keep a scale out of commission with long waiting periods to find the source of the issue.
- If your scale is to be positioned in a location where chronic downtime is going to be a problem, digital load cells provide the greatest solution to preventing unwanted interruptions and costly load cell repairs and replacements. Lightning-fast load cell diagnosis and quick-and-simple load cell replacement with superior protection create a massive windfall for the end-user that no longer needs to be squandered.



REMOTE MONITORING

iSITE REMOTE MONITORING For SmartCell® Digital Load Cells

2. WOULD YOU LIKE TO HAVE THE CAPABILITY OF REMOTELY MONITORING YOUR CUSTOMER'S TRUCK SCALE TO DIAGNOSE LOAD CELL ISSUES?

Remote, cloud-based monitoring provides truck scale owners with prompt diagnostic tools to immediately eliminate the painful guesswork associated with analog load cells.

- Cardinal Scale has developed its own software for remote monitoring called iSite. iSite is compatible with SmartCell® digital load cells and provides truck scale dealers the ability to remotely diagnose truck scales that they have installed from their PC or smartphone. The traditional method of having to randomly check wires to diagnose load cell and load-cell related failures is obsolete. Valuable time spent finding faulty wiring and having to pull wires is no longer necessary. Dealers can oftentimes know in advance which individual load cell has failed and the cause of the cell failure.
- iSite's Cloud-based dealer portal allows truck scale dealers to have a geographic view of digital truck scales they've installed. Each site displays a list of criteria related to that truck scale site and a load cell diagram will display the orientation of the load cells and note which cell is failing. Load cell data can be accessed to show diagnostics related to the cell regarding voltage, weight, calibration, and temperature readings. Dealers can immediately access the root cause of the failure and go to the truck scale location knowing which load cell needs to be replaced and why, so they can stock the correct equipment to take.
- iSite can also provide notifications to dealers related to load cell cables and home run cables as well. The truck scale's indicator can also be scanned for errors remotely. Dealers can access the status of peripheral equipment and provide a more complete look at the scale's data transmission system as a whole.
- If you do not have the capability to actively monitor your truck scale system, critical time spent searching for the root cause of the load cell issue can be rather extensive, depending on the nature and severity of the failure. You no longer have to wonder what the problem is—iSite already knows. This saves you, as the customer, time and money in service and maintenance costs.

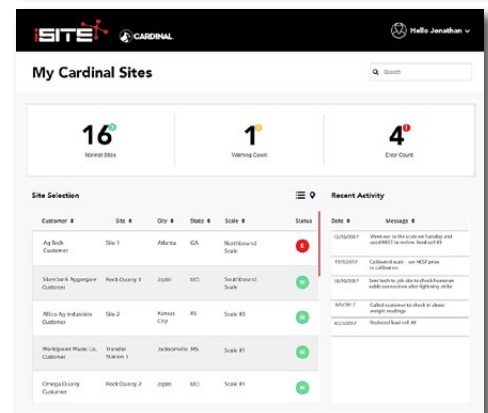
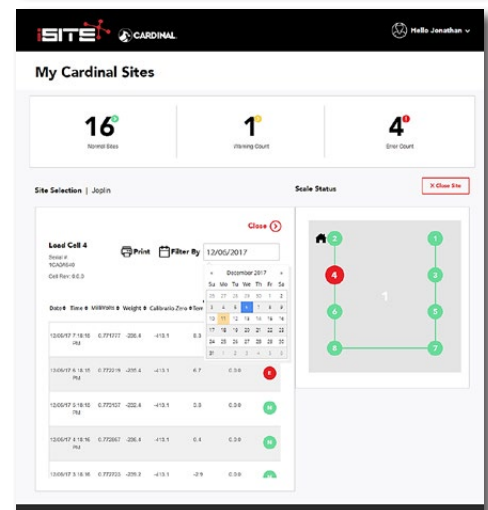
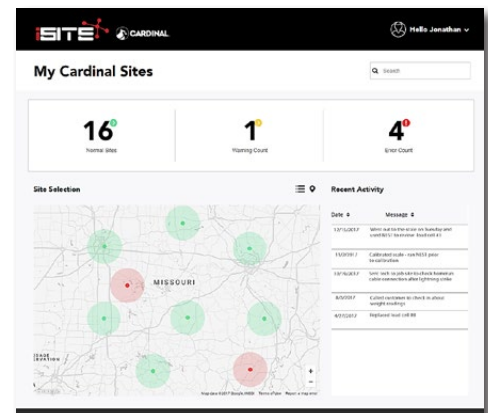

EXTREME TEMPERATURES

3. IS YOUR TRUCK SCALE APPLICATION SUBJECT TO EXTREME TEMPERATURES?

Extreme weather and temperatures will cause issues for analog load cells. SmartCell® digital load cells provide the much-needed protection to prevent important internal components from failure.

- ARMOR® load cells can operate in a wide range of temperatures. SmartCell® load cells are designed to function at high performance in a wide range of settings. Whether your scale is in an extreme environment or a location that has wildly fluctuating weather, SmartCell® digital load cells provide the stability needed to keep your scale weighing accurately.
- SmartCell® digital load cells feature a much more simplified wiring system than an analog truck scale system. Generally, within an analog eight-cell scale system there are up to 100 wires that have to be prepared and terminated correctly. Traditional analog wiring systems have several runs of wiring that can be exposed to the normal expansion and contraction caused by temperature fluctuations. SmartCell® digital load cells are connected point-to-point in a “daisy-chain” manner with shielded PVC cables; this reduced total wiring and greater wiring protection lessens the damaging effects of severe heat and cold on the ARMOR® digital truck scale system.
- If your scale location is in an area that that experiences load cell and wiring failures due to extreme hot and cold temperatures, SmartCell® digital load cell’s innovative design provides the most protection and return on your investment.



4. IS YOUR TRUCK SCALE SUBJECT TO DAMAGE FROM DIRT, GRIT, AND GRIME? ARE YOUR LOAD CELLS EXPOSED TO WATER?

SmartCell® digital load cells provide many layers of protection against damage from water and debris. The SmartCell's construction, placement, and ingress-blocking technology keep water and grime from damaging the load cells.

- As part of the axis® frictionless centering system that is provided, SmartCell® digital load cells are moved from an exposed area near the ground or beneath the deck to a placement above the bottom of the deck. Generally, most failures that are associated with debris and sediment build-up happen at the base of the truck scale near ground level, which greatly contributes to corrosion. SmartCell® digital load cells are given an extra layer of protection against the filth that typically accumulates under truck scales by being situated much higher in the scale weighbridge.
- If, by chance, water levels rise high enough to expose SmartCell® digital load cells to moisture, their rating provides the highest level of protection afforded: IP69K. Their stainless steel casing and potting-filled cell body prevents water from entering the load cell and damaging valuable digital components that transmit weighing information.
- SmartCell® load cell cables are also placed above the load cell housing to keep wiring clear of exposure to sediment and water. Load cell cables include rat-proofing protection from nibbling rodents.
- The orientation of the SmartCell® digital load cells in their load cell stand also provides the added bonus of self-cleaning. SmartCell® load cells rest on top of a cup-and-ball system that grinds up sediment and pollutants that might settle in the receiver cup from day-to-day operations. Normally this accumulation of pollutants would be left to build up and cause issues with load cell integrity or might cause inaccurate readings, but this self-cleaning feature can help protect the load cell modules from incorrect weighing.

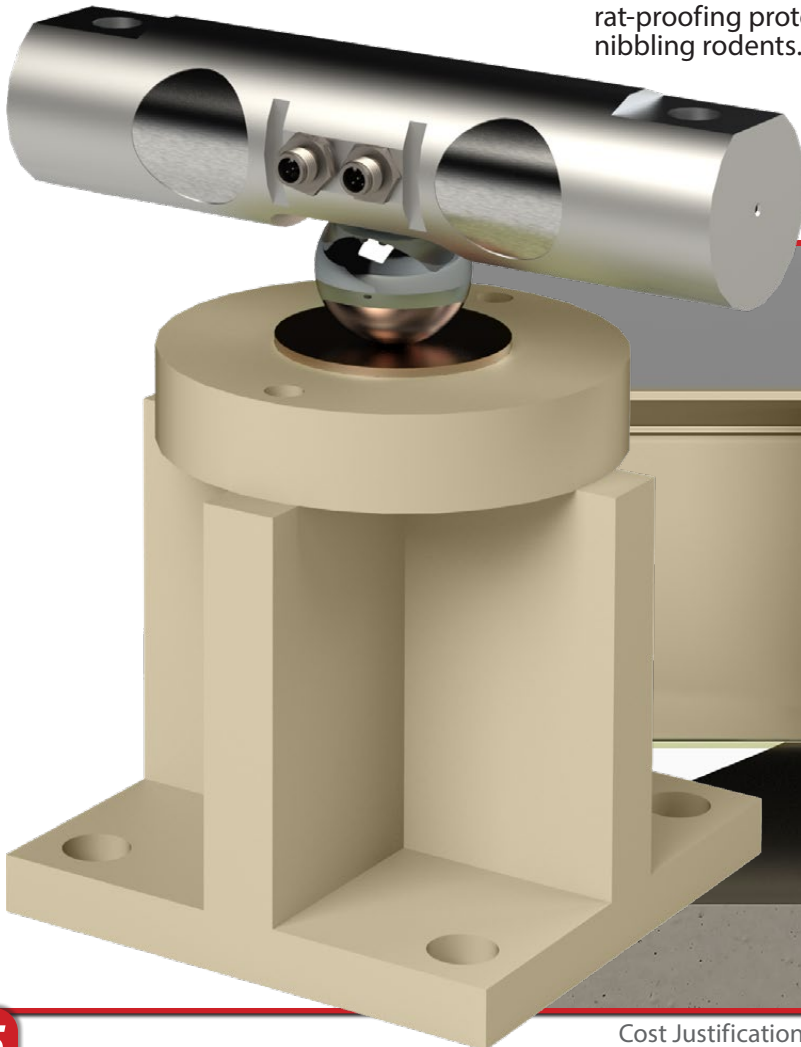

CHANGING OUT LOAD CELLS

5. DOES IT TAKE YOU A LONG TIME TO CHANGE OUT LOAD CELLS?

Replacing the SmartCell® load cell is incredibly simple. Most importantly, it is a very fast procedure that gets your scale back to work in rapid time.

- One of the most important upgrades the SmartCell® digital load cell offers is the ability for truck scale dealers to change out the load cell in a matter of minutes. Normally, with analog load cells, dealers will have to check, replace, or pull a whole host of wires from the summing box when changing one out. Now, Cardinal's digital load cells can be removed and replaced in as little as five minutes without any specialized equipment. It really is that short and simple!
- Electronic truck scales with analog load cells require many more moving parts. With an eight-cell system there are up to 100 wires that have to be prepared and terminated, up to 14 configuration jumpers to be set for proper operation, and sense lines must be utilized to regulate excitation voltage. This complicated wiring system lengthens time spent when trying to simply replace a load cell and calibrate it. This cumbersome process is no longer needed with the ARMOR® digital system.
- The ARMOR's simple load cell connector design and the axis® frictionless centering system's unique construction permit just a few steps for load cell replacement. After turning off power and jacking up the weighbridge a minimal amount, a single technician simply has to remove the dual load cell cables, remove two bolts that hold the cell to the weighbridge, and place a new load cell in its place. Next, after applying cleaner and Dielectric grease to the load cell cable connectors, the connectors are reconnected, and the load cell bolts are tightened. It's just that simple—not another moment needs to be spared on time-consuming load cell replacements.
- If you have to spend large amounts of time dealing with wiring analog load cells, the SmartCell® digital load cell streamlines the tedious task of getting your new load cell in operation.

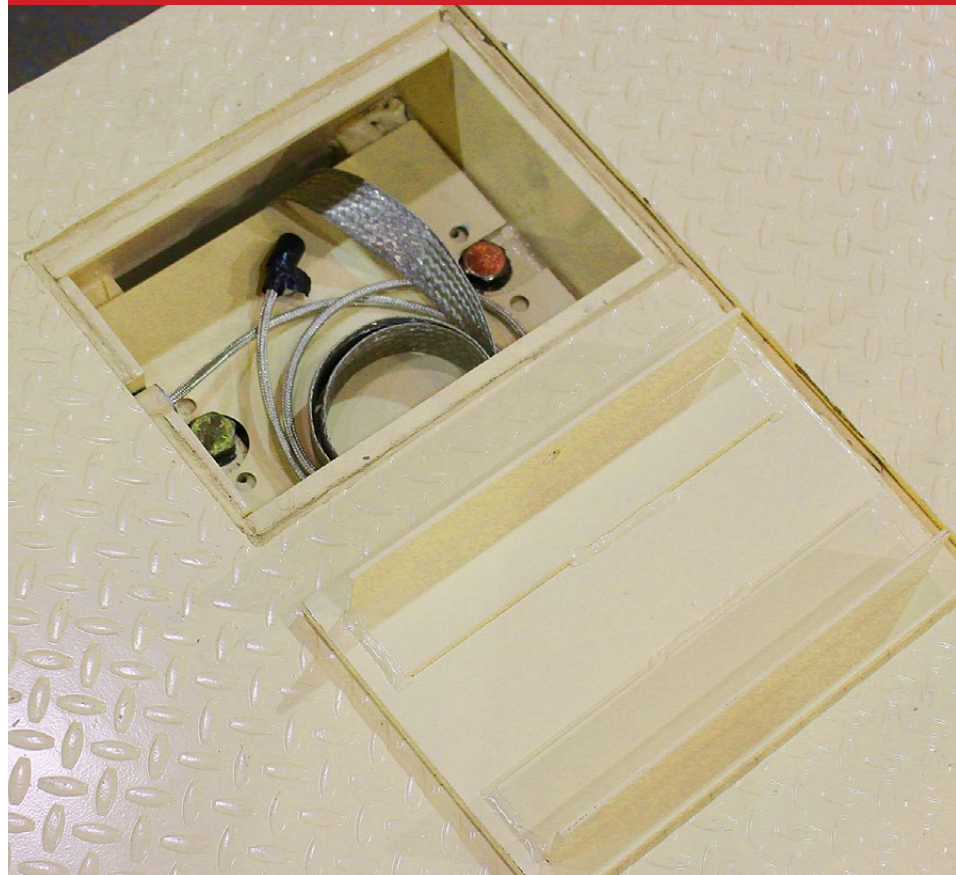

- Ease of use is also continued with installation or replacement of digital load cell (DLC) cards or 225D mainboards in the truck scale's weight indicator. The 225D indicator can detect whether either option has been replaced using checksums and board identification numbers. The new DLC card or 225D mainboard will be reconfigured to the existing scale by the indicator acknowledging the new card and asking the user to verify if it is new. This simple reconfiguration process saves time and effort.

225 
NAVIGATOR



6. ARE LIGHTNING STRIKES AND POWER SURGES AN ISSUE FOR YOUR TRUCK SCALE?

Lightning strikes are one of the most common difficulties that can affect a truck scale. SmartCell® digital load cells provide superior protection that protects against electrical uncertainties.

- Truck scales, due to their composition and size, are a magnet for attracting lightning. Many times, these scales are placed in an outdoor area that is exposed to the elements. The main front of protection against lightning strikes and power surges lies in the junction box. Unfortunately, if the junction box is compromised it can cause damage to the whole load cell weighing system. One or more of the load cells can be damaged in a traditional load cell arrangement, which can come at a great cost.
- The gas discharging tubes that divert excess voltage from lightning and power surges are normally placed inside the summing box of analog load cell systems. Cardinal's SmartCell® digital load cells have the apparatus of discharging excess voltage placed in each load cell. This ability for each load cell to individually protect itself provides another line of protection for the whole load cell system. If a lightning strike or power surge happens, one load cell has the capability of preventing damaging surges from passing onto other load cells.
- Unfortunately, lightning strikes and power surges are commonplace. These occurrences have the potential to wreak havoc on truck scale electronics. Luckily, Cardinal's SmartCell® digital load cells can protect individual load cells and the entire load cell system from excessive damage caused by freak electrical incidents.
- If you've experienced reoccurring problems with damaged load cells and repairs caused by lightning and power surges, SmartCell® digital load cells can help protect your truck scale electronics against severe damage.



DATA TRANSMISSION ERRORS

7. DO YOU FREQUENTLY SUFFER FROM DATA TRANSMISSION ERRORS? DO YOUR ANALOG LOAD CELLS RECURRENTLY SEND INCORRECT OR MISLEADING READINGS?

Analog load cells face numerous factors that can interfere with transmitting load cell information. SmartCell's digital information processing eliminates problems caused by analog signals.

- One of the major differences between digital load cells and analog load cells is the method by which signals are transmitted. Analog load cells transmit data via electrical voltages, while digital load cells are converted to digital signaling. Digital signaling uses higher voltages to transmit data, providing the signal with much higher strength. Voltage fluctuations are much more likely to affect the quality of the analog signals that can cause misreadings and incorrect information.
- The SmartCell's signal content is much different than the analog load cell's content. The digital signal is composed of binary information that is commonly found in computer data transmission. This digital transmission stream is not prone to interference from outside influences such as temperature, electromagnetism, and radio frequencies and signals. SmartCell® digital load cells will not suffer from signal degradation caused by external influences like analog load cells.
- If your current electronic truck scale suffers from degraded signaling, lack of reliable information, or misreadings, you should consider Cardinal Scale's SmartCell® digital load cells.

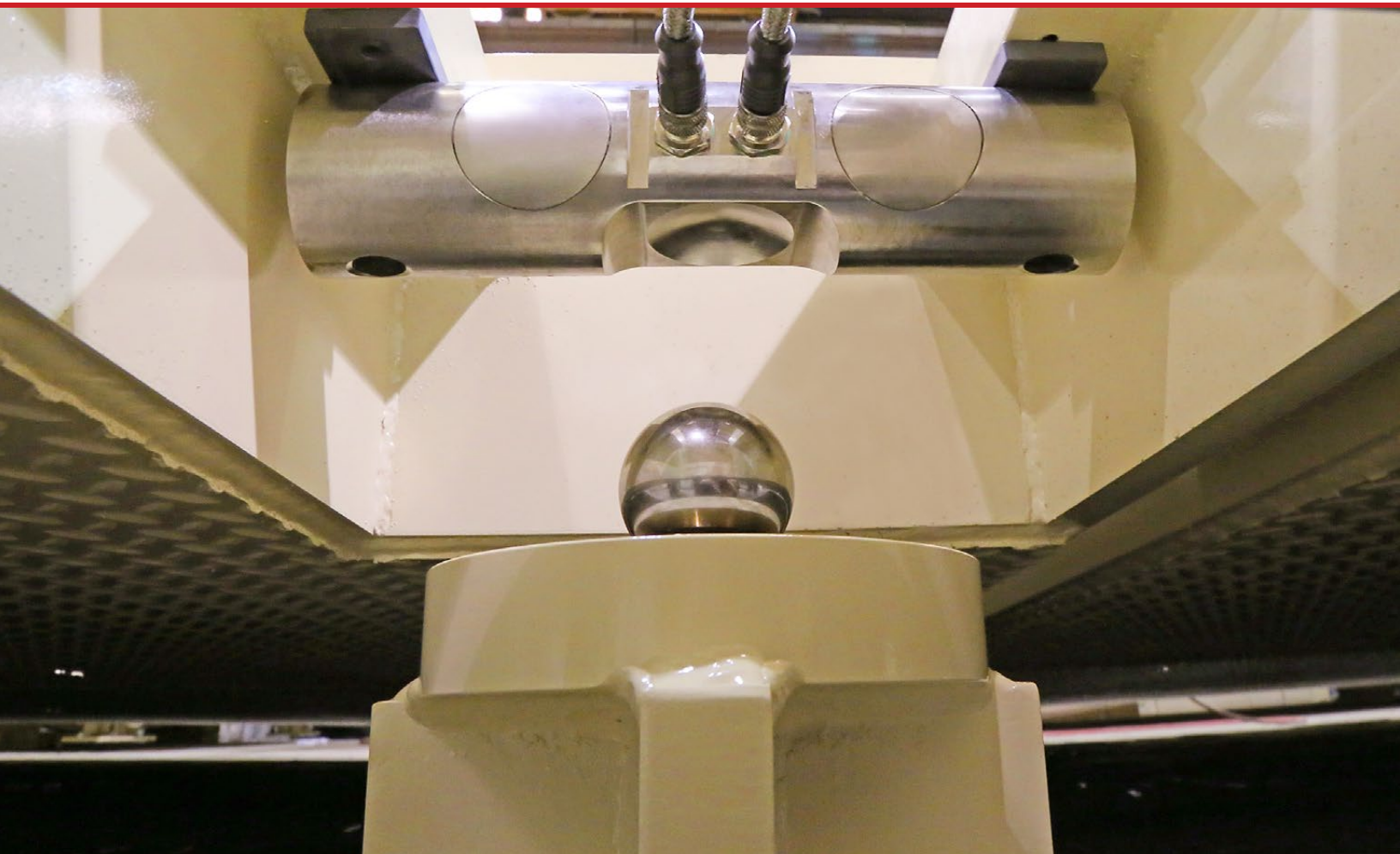

COST JUSTIFICATION FACTORS

ARMOR® COST JUSTIFICATION FACTORS

If you consider one of the aforementioned issues problematic, Cardinal Scale's ARMOR® digital truck scales can provide the solutions you need.

The ARMOR® provides a great leap forward in truck scale technology. Costly load cell diagnosis, replacement costs, and load cell damage have been greatly reduced due to the ARMOR's paradigm-changing technology.

Carefully consider the following cost factors affecting your bottom line:

- 1.** If your current scale system lacks remote monitoring, factor in the time and costs spent in trying to diagnose the true failure in the weighing system. Diagnosing a load cell or cable failure can take anywhere from a few hours to a few days... sometimes more. The costs associated with not having your scale in use for that stretch of time can be as expensive as losing a day's business.
- 2.** What are the costs associated with constantly having to repair an analog truck scale's inefficient and delicate wiring system?
- 3.** What are the labor costs associated with changing a load cell should it fail? Most load cells cost \$1,500 to \$2,000, and don't forget to consider the labor associated with replacing a faulty load cell. Additionally, don't neglect to factor in the return trip charges associated with having to constantly replace faulty load cells. Return trip charges are a cost that adds up over time and can become a considerable sum.
- 4.** Routine cleaning and maintenance for load cells that are exposed to debris and moisture can add more costs to the ownership of a truck scale.
- 5.** If your truck scale is in a location that is susceptible to lightning and power surges, digital load cells are a fantastic safeguard to protect your weighing operations.



CONCLUSION

Load cell and wiring repairs can be incredibly costly—not only monetarily, but in scale downtime as well. The lack of certainty in being able to properly diagnose a truck scale's failures can result in a great variance of time spent and the costs associated with correcting the issue. Now, end-users and dealers have the power of knowing what is happening in real time. The reassurance that the system in place will correctly diagnose and expedite repairs is a great boon to the truck scale owner. In addition, advantageous load cell placement within the truck scale, protection against lightning, water, and debris, and the simplicity of replacing load cells provides a complete system of protection against the most depleting and common causes of truck scale downtime.

Since Cardinal Scale manufactures its truck scales and the accompanying technology in the United States at their factory in Webb City, MO and doesn't outsource its truck scale or electronics manufacturing, Cardinal can provide real solutions that benefit its customers to keep their business. Cardinal has kept their finger on the pulse of what end-users need, and provided groundbreaking solutions to help their customers save their hard-earned profits by providing efficient and tech-savvy solutions.

Cardinal's SmartCell® digital load cells protect your investment in what is sure to be a major financial consideration. SmartCell® digital load cells offer not only the best defense against weather, water, lightning, and debris build-up, but do so in an expedient and cost-effective manner. Time and money are very precious commodities, and the ARMOR® digital truck scale provides the best solution needed for giving you back control of both.

Cardinal Scale has once again pushed the weighing industry forward with its investment in raising the technological bar. If you would like to move your truck scale operation into the future and beyond, Cardinal Scale will provide the path forward with the ARMOR® digital truck scale.





COST JUSTIFICATION GUIDE



102 East Daugherty St., Webb City, MO 64870 USA
Toll-Free: (800) 441-4237 E-mail: cardinal@cardet.com
www.CardinalScale.com

Cardinal Scale reserves the right to improve, enhance, or modify features and specifications without prior notice.