



CARDINAL®

ARMOR®

TRUCK SCALES

SMARTCELL®

DIGITAL LOAD CELLS

CONCRETE DECK SERIES

- *Pour-in-place concrete deck weighbridge*
- *SmartCell® stainless steel, waterproof digital load cells*
- *No moving parts below the scale deck, including load cells*
- *IoT-enabled iSite remote monitoring software*
- *High 50-ton CLC standard*



UNDISPUTED HEAVYWEIGHT CHAMPION

Cardinal Scale's ARMOR® series digital truck scales with SmartCell® load cells offer unmatched performance built to last a lifetime of heavy-duty weighing use. Every facet of the scale weighbridge and electronics have been specifically built for long-lasting endurance, minimal upkeep, and IoT monitoring convenience. The concrete deck series offers long-lasting, baked-on, anti-corrosion tan powder coat paint finish. Backup sheeting and deck reinforcing steel are ready for concrete to be poured onsite without the use of any rebar.

POUR-IN-PLACE CONCRETE DECK TRUCK SCALES FOR LOW-PROFILE OR PIT INSTALLATIONS



EXCLUSIVE LOAD CELL PROTECTION

Load cells are the most sensitive part of any truck scale and Cardinal Scale offers the ultimate protection in the ARMOR's SmartCells. Each IP69K-rated waterproof stainless steel load cell is completely encapsulated and filled with a potting compound to fill all internal voids and prevent any potential for moisture entering the load cell and causing premature failure.

SmartCell® digital load cell cables are metal braided and run in a continuous galvanized steel conduit for optimal protection against rodents.



225
NAVIGATOR

iSITE

The Cloud-based iSite remote monitoring software comes standard with all ARMOR digital truck scales and offers e-mail and/or text alerts to authorized Cardinal Scale dealers ensuring your scale is performing at all times during peak operations.

Cardinal's 225D Navigator weight indicator provides truck ID numbers and truck tares, plus diagnostic readouts onscreen for individual digital load cells.



EXCLUSIVE CON-LOCK DECKS

The ARMOR's exclusive CON-LOCK concrete deck design is field ready for the pouring of concrete and features an exclusive flow-through design that alleviates the need for any rebar to be installed in the weighbridge.

TAKE A LOOK INSIDE AN ARMOR® WEIGHBRIDGE TO SEE WHY IT'S THE BEST TRUCK SCALE ON THE MARKET

ARMOR® concrete deck weighbridges can provide better traction in wet or icy weather and are ideal for above ground and pit applications.



TOP-SIDE ACCESS TO LOAD CELLS

The concrete deck ARMOR® offers no-bolt easy-access covers to the stainless steel digital SmartCell® load cells. The ARMOR's interconnecting scale decks are fabricated with precision-cut machined components for exacting quality.



Cardinal Scale's SmartCell® digital load cells are the newest solution in advanced load cell technology. Messy, time-consuming wiring is no longer necessary—cables connect plug-and-play to the cell through metal braided rodent-proof cables. An added bonus for such a simple cell-to-cable design is load cells are linked directly to one another, yielding a more convenient, user-friendly load cell system. Internal cell circuitry eliminates the need for a junction box. Individual cells may be monitored remotely via iSite Cloud-based software.



axis® Frictionless Centering System

Cardinal Scale's axis® frictionless centering system is the new frontier for load-centering technology and provides gravity-driven dynamic centering. The axis' durable ball suspension system utilizes gravity to restrain deck movement and vibration; in fact, the heavier the load is, the better. Since the ball is constantly seeking its radius in the stand cup below and the load cell above, it will absorb movements from the truck moving on the weighbridge and bring the weighbridge to rest more quickly and smoothly.

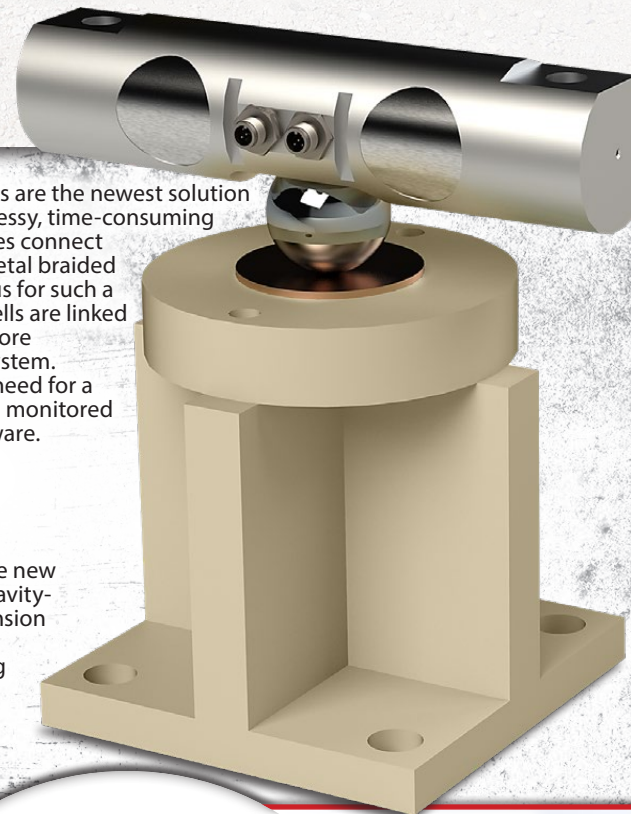

HIGH LOAD CELL POSITIONING YIELDS MULTIPLE BENEFITS

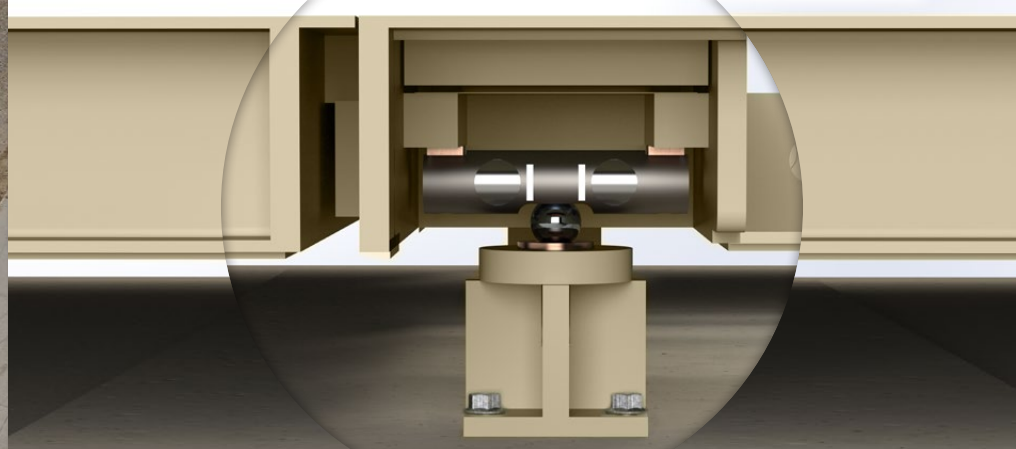

There are no moving parts below the ARMOR® weighbridge, including the load cells, which eliminates build-up failures due to corrosion, sediment, and debris. The axis® load cell stands are fabricated from one-inch-thick steel to minimize rust and corrosion damage and ensure long-term strength and durability.





**ARMOR® Digital Truck Scale
Concrete Deck Models**

LENGTH	Overall Capacity	CLC	Number Of Sections	WIDTH			
				10 Ft.	11 Ft.	12 Ft.	14 Ft.
12 ft.	50 tons	50 tons	2	1010300	1010319	1010338	1010357
20 ft.	50 tons	50 tons	2	1010301	1010320	1010339	1010358
25 ft.	50 tons	50 tons	2	1010302	1010321	1010340	1010359*
30 ft.	70 tons	50 tons	3	1010303	1010322	1010341	1010360
40 ft.	70 tons	50 tons	3	1010304	1010323	1010342	1010361
47 ft.	70 tons	50 tons	3	1010305	1010324	1010343	1010362
50 ft.	80 tons	50 tons	4	1010306	1010325	1010344	1010363
60 ft.	110 tons	50 tons	4	1010307	1010326	1010345	1010364
70 ft.	135 tons	50 tons	4	1010308	1010327	1010346	1010365*
75 ft.	135 tons	50 tons	4	1010309	1010328	1010347	1010366*
80 ft.	135 tons	50 tons	5	1010310	1010329	1010348	1010367
90 ft.	135 tons	50 tons	5	1010311	1010330	1010349	1010368
100 ft.	135 tons	50 tons	6	1010312	1010331	1010350	1010369*
110 ft.	135 tons	50 tons	6	1010313	1010332	1010351	1010370
117 ft.	135 tons	50 tons	6	1010314	1010333	1010352	1010371*
120 ft.	135 tons	50 tons	6	1010315	1010334	1010353	1010372*
125 ft.	135 tons	50 tons	6	1010316	1010335	1010354	1010373*
140 ft.	135 tons	50 tons	7	1010317	1010336	1010355	1010374*
160 ft.	135 tons	50 tons	8	1010318	1010337	1010356	1010375*

* This 14 ft. wide model will have 1 additional section added to that listed above.

**ARMOR® Digital Truck Scale
Concrete Deck Multi-Platform Models**

LENGTH	Overall Capacity	CLC	WIDTH
			11 Ft.
12, 20, 40 ft.	135 tons	50 tons	1010850
15, 15, 50 ft.	135 tons	50 tons	1010851
20, 20, 40 ft.	135 tons	50 tons	1010852

CLC = Concentrated Load Capacity: The maximum axle-load concentration for a group of two axles with a center line spaced 4' apart and an axle width of 8' that can safely be applied to the scale.

Other sizes and capacities readily available. Please consult the Cardinal Scale factory for more options.



LEGAL FOR TRADE

ARMOR Weighbridge:
Cert. No. 17-047

SCBD Load Cell:
Cert. No. 16-088



Notice of Approval
AM-4890



Cardinal Scale reserves the right to improve, enhance, or modify features and specifications without prior notice.

SOLD BY:



102 East Daugherty St., Webb City, MO 64870 USA
Toll-Free: (800) 441-4237 E-mail: cardinal@cardet.com
www.CardinalScale.com