



CARDINAL®



ARMOR® TRUCK SCALES

SMARTCELL® DIGITAL LOAD CELLS

STEEL DECK SERIES

- SmartCell® stainless steel, waterproof digital load cells
- No moving parts below the scale deck, including load cells
- IoT-enabled iSite remote monitoring software
- Heavyweight 50-ton CLC standard



LEGAL FOR TRADE

Cardinal Scale's ARMOR® digital truck scales come in a wide variety of standard models available (listed on the back page), plus custom-engineered designs.



UNDISPUTED HEAVYWEIGHT CHAMPION



DIGITAL TRUCK SCALES OFFERING UNMATCHED PERFORMANCE BUILT TO LAST A LIFETIME

Cardinal Scale's ARMOR® series digital truck scales with SmartCell® load cells offer unmatched performance built to last a lifetime of heavy-duty weighing use. Every facet of the scale weighbridge and electronics have been specifically built for long-lasting endurance, minimal upkeep, and IoT monitoring convenience. The long-lasting, baked-on, anti-corrosion tan powder coat paint finish ensures a lifetime of trouble-free protection.

The NTEP legal-for-trade ARMOR® series arrives fully prepared for quick installation with load cells and stands pre-installed. Cardinal Scale's unique axis® frictionless centering system provides gravity-driven dynamic centering to restrain deck movement and vibration. Every ARMOR® steel deck truck scale is 100% assembled, pre-calibrated, and tested before shipping.



EXCLUSIVE LOAD CELL PROTECTION

Load cells are the most sensitive part of any truck scale and Cardinal Scale offers the ultimate protection in the ARMOR's SmartCells. Each IP69K-rated waterproof stainless steel load cell is completely encapsulated and filled with a potting compound to fill all internal voids and prevent any potential for moisture entering the load cell and causing premature failure.

SmartCell® digital load cell cables are metal braided and run in a continuous galvanized steel conduit for optimal protection against rodents.



225 NAVIGATOR



The Cloud-based iSite remote monitoring software comes standard with all ARMOR digital truck scales and offers e-mail and/or text alerts to your authorized Cardinal Scale dealer ensuring your scale is performing at all times during peak operations.

Cardinal's 225D Navigator weight indicator provides truck ID numbers and truck tares, plus diagnostic readouts onscreen for individual digital load cells.

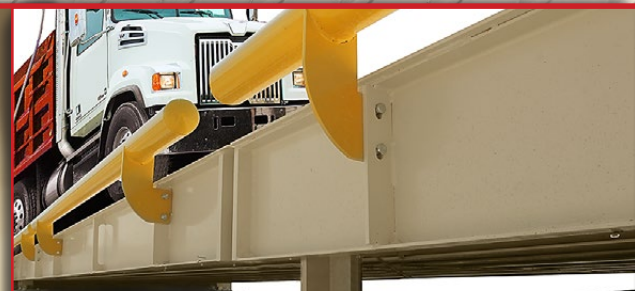

Optional bolt-on guide rails are available to help drivers stay centered on the scale.



TAKE A LOOK INSIDE AN ARMOR® WEIGHBRIDGE TO SEE WHY IT'S THE BEST TRUCK SCALE ON THE MARKET

MORE STRUCTURAL STEEL THAN THE COMPETITION

ARMOR® steel deck weighbridges utilize a tight concentration of 7.5-inch I-beam spacing which minimizes unsupported deck plate area and ensures that truck tire contact patches are always directly supported by one I-beam. Four rows of welded stiffeners provide maximum structural rigidity and safeguard against I-beam deflection under loads for optimal strength and longevity.



axis® Frictionless Centering System

Cardinal Scale's axis® frictionless centering system is the new frontier for load-centering technology and provides gravity-driven dynamic centering. The axis' durable ball suspension system utilizes gravity to restrain deck movement and vibration; in fact, the heavier the load is, the better. Since the ball is constantly seeking its radius in the stand cup below and the load cell above, it will absorb movements from the truck moving on the weighbridge and bring the weighbridge to rest more quickly and smoothly.

Cardinal Scale's SmartCell® digital load cells are the newest solution in advanced load cell technology. Messy, time-consuming wiring is no longer necessary—cables connect plug-and-play to the cell through metal braided rodent-proof cables. An added bonus for such a simple cell-to-cable design is load cells are linked directly to one another, yielding a more convenient, user-friendly load cell system. Internal cell circuitry eliminates the need for a junction box. Individual cells may be monitored remotely via iSite Cloud-based software.

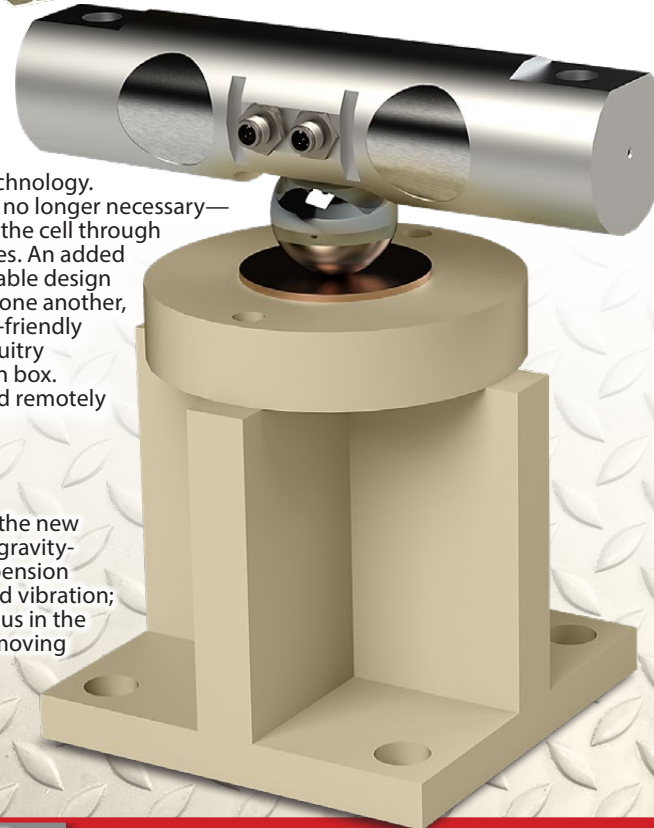

HIGH LOAD CELL POSITIONING YIELDS MULTIPLE BENEFITS

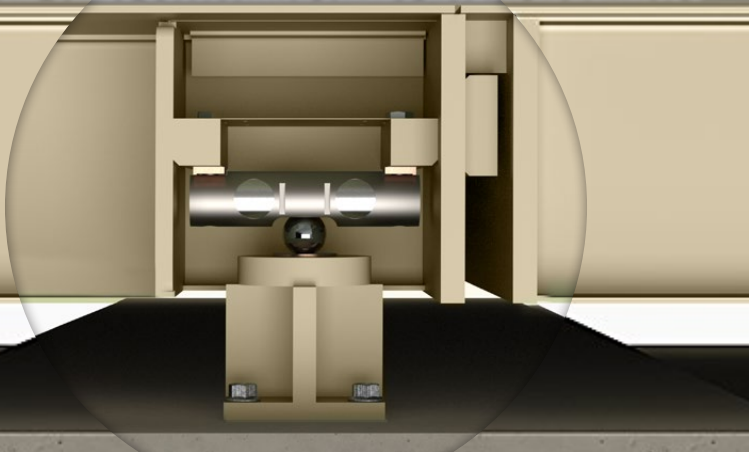

There are no moving parts below the ARMOR® weighbridge, including the load cells, which eliminates build-up failures due to corrosion, sediment, and debris. The axis® load cell stands are fabricated from one-inch-thick steel to minimize rust and corrosion damage and ensure long-term strength and durability.

WEIGHBRIDGE DESIGN STRENGTH ADVANTAGES

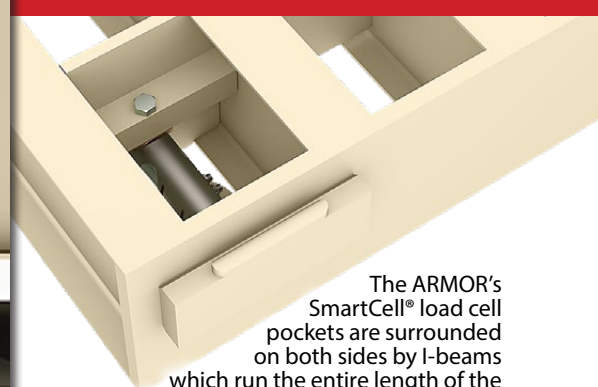

The ARMOR's SmartCell® load cell pockets are surrounded on both sides by I-beams which run the entire length of the weighbridge. This alleviates any potential structural weakness around the load cell region like in competitors' truck scales. The no-bolt bridge connections feature interconnecting load blocks and receivers welded directly to the I-beams for strength and durability.



ARMOR[®]

TRUCK SCALES

SMARTCELL[®]

DIGITAL LOAD CELLS

ARMOR[®] Digital Truck Scale Steel Deck Models

LENGTH	Overall Capacity	CLC	Number Of Sections	WIDTH			
				10 Ft.	11 Ft.	12 Ft.	14 Ft.
12 ft.	50 tons	50 tons	2	1010200	1010219	1010238	1010257
20 ft.	50 tons	50 tons	2	1010201	1010220	1010239	1010258
25 ft.	50 tons	50 tons	2	1010202	1010221	1010240	1010259
30 ft.	70 tons	50 tons	3	1010203	1010222	1010241	1010260
40 ft.	70 tons	50 tons	3	1010204	1010223	1010242	1010261
47 ft.	70 tons	50 tons	3	1010205	1010224	1010243	1010262
50 ft.	80 tons	50 tons	4	1010206	1010225	1010244	1010263
60 ft.	110 tons	50 tons	4	1010207	1010226	1010245	1010264
70 ft.	135 tons	50 tons	4	1010208	1010227	1010246	1010265
75 ft.	135 tons	50 tons	4	1010209	1010228	1010247	1010266
80 ft.	135 tons	50 tons	5	1010210	1010229	1010248	1010267
90 ft.	135 tons	50 tons	5	1010211	1010230	1010249	1010268
100 ft.	135 tons	50 tons	6	1010212	1010231	1010250	1010269
110 ft.	135 tons	50 tons	6	1010213	1010232	1010251	1010270
117 ft.	135 tons	50 tons	6	1010214	1010233	1010252	1010271
120 ft.	135 tons	50 tons	6	1010215	1010234	1010253	1010272
125 ft.	135 tons	50 tons	6	1010216	1010235	1010254	1010273
140 ft.	135 tons	50 tons	7	1010217	1010236	1010255	1010274
160 ft.	135 tons	50 tons	8	1010218	1010237	1010256	1010275



LEGAL FOR TRADE

ARMOR Weighbridge:
Cert. No. 17-047

SCBD Load Cell:
Cert. No. 16-088



MEASUREMENT CANADA

Notice of Approval
AM-4890



ARMOR[®] Digital Truck Scale Steel Deck Multi-Platform Models

LENGTH	Overall Capacity	CLC	WIDTH
			11 Ft.
12, 20, 40 ft.	135 tons	50 tons	1010750
15, 15, 50 ft.	135 tons	50 tons	1010751
20, 20, 40 ft.	135 tons	50 tons	1010752

CLC = Concentrated Load Capacity: The maximum axle-load concentration for a group of two axles with a center line spaced 4' apart and an axle width of 8' that can safely be applied to the scale.

Other sizes and capacities readily available. Please consult the Cardinal Scale factory for more options.

Cardinal Scale reserves the right to improve, enhance, or modify features and specifications without prior notice.

SOLD BY:



102 East Daugherty St., Webb City, MO 64870 USA
Toll-Free: (800) 641-4237 E-mail: cardinal@cardet.com
www.CardinalScale.com