



CARDINAL®

CBC50K / CBC75K

Compression Weighing Load Cells



- 50,000 lb/22,500 kg and 75,000 lb/34,000 kg capacities
- Anti-rotation pivot inserts
- Environmentally-sealed (IP68)
- Stainless steel construction
- NTEP legal for commercial trade
- 75'/23m integral shielded cable

These heavy-capacity, compact compression load cells are ideal for multiple load cell weighing applications such as truck scales and heavy-duty tank weighing systems. The load cells are fabricated from stainless steel to provide the ultimate in protection when caustic, corrosive or wet environments are encountered. Load cells are environmentally-sealed IP68 with a welded stainless steel cup for absolute water protection.

MECHANICAL DATA

Rated Capacity, (R.C.) E _{max}	CBC50K: 50,000 lb / 22,500 kg CBC75K: 75,000 lb / 34,000 kg
Minimum Dead Load	1.6% of dead load
Safe Load Limit	150% R.C.
Ultimate Load	300% R.C.
Deflection at R.C.	0.015 in / 0.38 mm
Spring Element Material	17-4 PH

CERTIFICATE DATA

Issuing Body	NTEP
Certificate Number	11-094
Accuracy Class	IIIL
Maximum Number of Load Cell Intervals, n _{max}	10,000
Single/Multiple	M
Minimum Load Cell Verification Interval V _{min} NTEP	2 lb / 0.9 kg

ELECTRICAL DATA

Rated Output	2 ± 0.1% mV/V
Excitation Voltage, Maximum	15 VDC
Cable Length	75 ft / 23 m
Terminal Resistance	
Excitation	787 ± 40 ohms
Signal	702 ± 10 ohms
Zero Load Output	± 1% R.C.
Insulation Resistance	>5000 megohms at 50 VDC

ENVIRONMENTAL DATA

Temperature Compensation Range	-10 to +40°C
Operating Temperature Range	-29 to +93°C
Construction & Protection Code	IP68
Barometric Pressure Effect on Zero Load Output	<1 v (min)/1kPa

The top and bottom hardened mating surfaces with the CBC load cell must have a minimum hardness of 40 Rockwell C.

SCALE

CBC

Compact Power

**Stainless Steel Compression
Weighing Load Cells Featuring
Anti-Rotation Pin Inserts**

Models/Capacities

CBC50K: 50,000 lb / 22,500 kg
CBC75K: 75,000 lb / 34,000 kg

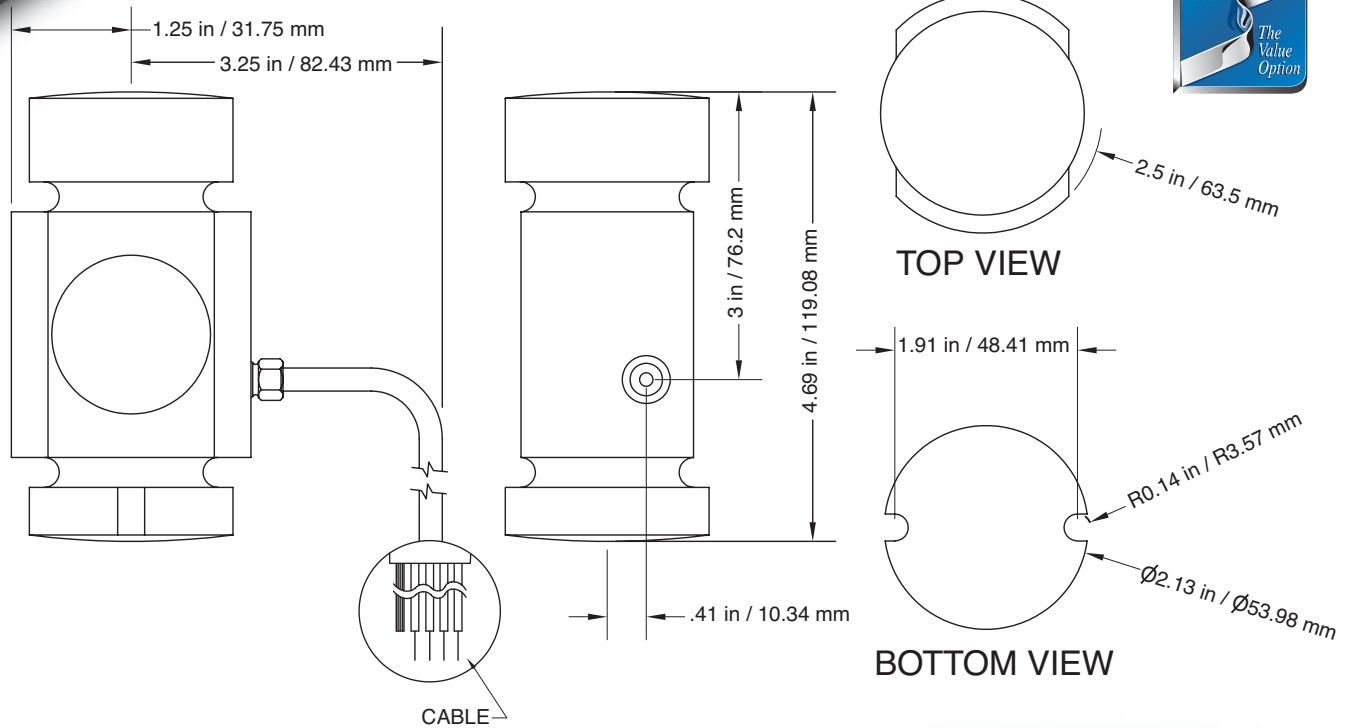

ELECTRICAL INFORMATION

- Red + excitation
- Black - excitation
- Yellow shield
- Green + signal
- White - signal



CERTIFICATIONS

The Model CBC50K and CBC75K Load Cells meet or exceeds Class III, 10,000 division accuracy requirements in accordance with NIST Handbook 44. A Certificate of Conformance (Number 11-094) has been issued under the National Type Evaluation Program (NTEP) of the National Conference on Weights and Measures.

VCAP CERTIFIED

Cardinal Scale has been formally audited and found to be fully compliant with the Verified Conformity Assessment Program (VCAP) administered by the National Type Evaluation Program (NTEP) of the National Conference on Weights and Measures (NCWM).

Cardinal Scale reserves the right to improve, enhance or modify features and specifications without prior notice. All registered trademarks are the property of their respective owners.



SOLD BY:



102 East Daugherty St., Webb City, MO 64870 USA
Toll-Free: (800) 441-4237 E-mail: cardinal@cardet.com
www.CardinalScale.com