

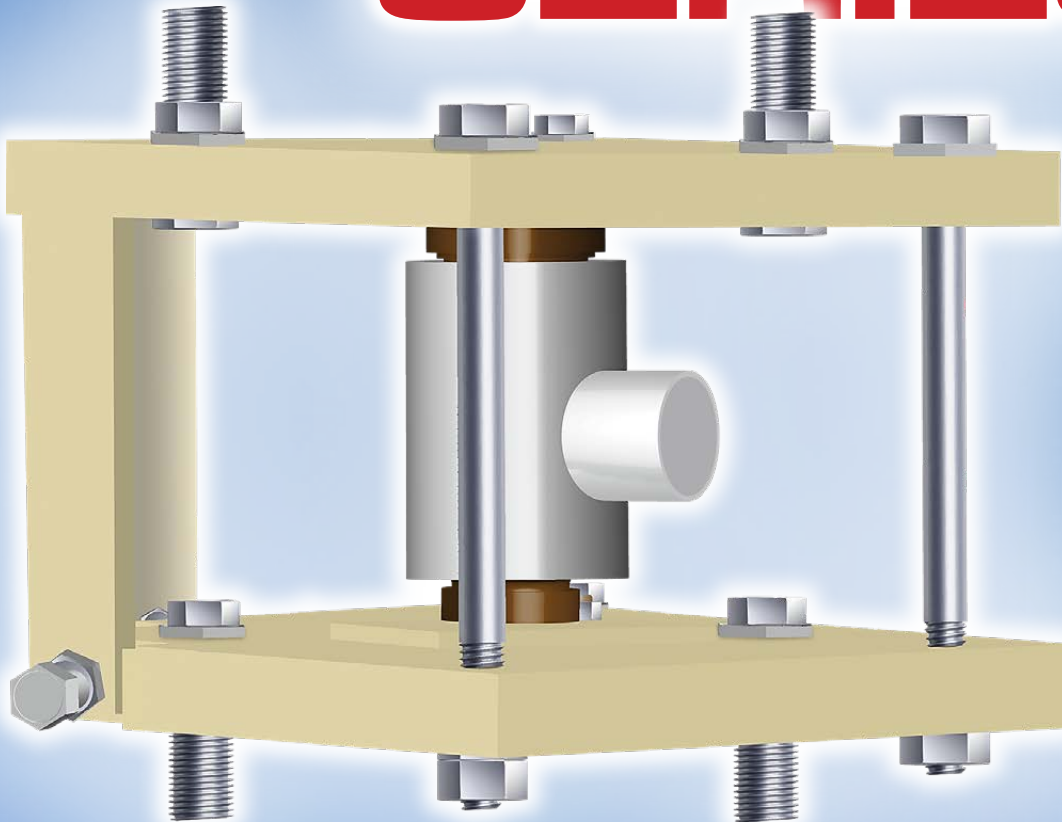

CARDINAL®

CCL-SCA SERIES



HEAVY-CAPACITY VESSEL WEIGHING LOAD CELL KITS

- High-Capacity Self-Checking Load Cell Stands
- Weigh Tanks, Bins, and Hoppers
- Wide Variety of System Capacities Available up to 800,000 lb / 363,000 kg
- Stainless Steel SCA Compression Load Cells
- Includes Stainless Steel Junction Box and 50 ft/15 m Interconnect Cable
- Bolts Directly to Floor and Tank

CCL-SCA SERIES LOAD CELL KITS

HEAVY-CAPACITY VESSEL WEIGHING MOUNTING ASSEMBLIES

Standard System Capacities Available From 150,000 lb / 68,000 kg up to 800,000 lb / 363,000 kg (additional sizes available)

- Precision Engineering
- Environmentally-Sealed Stainless Steel Load Cells
- Ideal for New Installations or Conversions
- Rugged Bolt-in-Place Design
- 18.5 in x 18.5 in / 47 cm x 47 cm Heavy-Duty Steel Plates
- Self-Checking Eliminates the Need for External Hardware
- Accommodates Multi-Legged Tanks with up to 10 Legs

Cardinal Scale's CCL-SCA series floor stand tank scales are designed for weighing heavy-capacity static concentric loads. The stands come with Cardinal Scale's SCA series stainless steel weather proof load cells. The compact construction of the stands minimizes installation time.

Each CCL-SCA series unit installs quickly without the need for additional external stabilizing hardware. Whether tank, hopper, or vessel weighing, the heavy-duty stand design will provide you with years of reliable, accurate weighing operation. Combine them with one of Cardinal Scale's digital weight indicators for a complete vessel weighing system with connectivity to a multitude of devices and networks.

Wide Selection of Weight Indicators Available



Model	No. of Mounting Stands	Load Cell Capacity	Overall System Capacity
CCL50K-SCA-3	3	50,000 lb / 22,700 kg	150,000 lb / 68,000 kg
CCL100K-SCA-3	3	100,000 lb / 45,000 kg	300,000 lb / 136,000 kg
CCL120K-SCA-3	3	120,000 lb / 54,000 kg	360,000 lb / 163,000 kg
CCL200K-SCA-3	3	200,000 lb / 90,000 kg	600,000 lb / 272,000 kg
CCL50K-SCA-4	4	50,000 lb / 22,700 kg	200,000 lb / 90,000 kg
CCL100K-SCA-4	4	100,000 lb / 45,000 kg	400,000 lb / 181,000 kg
CCL120K-SCA-4	4	120,000 lb / 54,000 kg	480,000 lb / 217,000 kg
CCL200K-SCA-4	4	200,000 lb / 90,000 kg	800,000 lb / 363,000 kg

Kits include: Stainless steel SCA load cells, mild steel load cell stands powder coat painted industrial tan, 1 load cell trim box, and 50 ft/15 m interconnect cable.

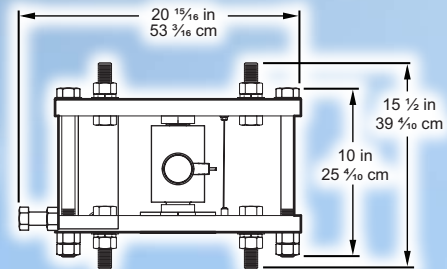
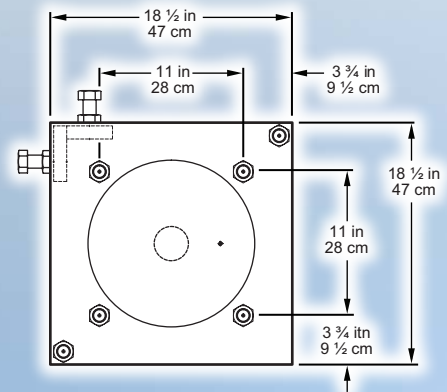

These sizes shown in the diagram are for 50K, 100K, and 120K SCA load cells. Consult factory for 200K SCA load cell stand dimensions.

Cardinal Scale reserves the right to improve, enhance, or modify features and specifications without prior notice.



102 East Daugherty St., Webb City, MO 64870 USA
Toll-Free: (800) 441-4237 E-mail: cardinal@cardet.com
www.CardinalScale.com

SOLD BY: