



# HSB Series

## Light to Medium Capacity Shear Beam Load Cells



- 500, 1,000, 2,000, and 5,000 kg capacities
- Hermetically-sealed, fully-welded, IP68 (EN 60529) and IP69K (ISO 20753) stainless steel construction
- 3000 divisions OIML R60 class C
- Pre-corner adjustment optimized for multicell systems

Cardinal Scale's 500-kg, 1,000-kg, 2,000-kg, and 5,000-kg capacity HSB series stainless steel shear beam load cells have a low profile design that is hermetically sealed and fully welded at IP68 (EN 60529) and IP69K (ISO 20753) rating. They are made specifically for light to medium weighing applications. The HSB series load cells are rated at 3,000 divisions OIML R60 class C. The precorner adjustment is optimized for multicell systems. They are high accuracy for applications like four load cell platforms, floor scales, and tank and hopper weighing. 3 m/10 ft load cell cable is provided.

### SPECIFICATIONS <sup>< ±2</sup>

Accuracy Class	3000	n. OIML
Minimum Dead Load	0	%Ln
Service Load	150	%Ln
Safe Load Limit	200	%Ln
Total Error	< ±0.017	%Sn <sup>1</sup>
Repeatability Error	< ±0.015	%Sn
Temperature Effect:		
On Zero	< ±0.01	%Sn/5 °C
On Sensitivity	< ±0.06	%Sn/5 °C
Creep Error (30 minutes)	< ±0.016	%Sn
Temperature Compensation	-10 to +40	°C
Temperature Limits	-30 to +70	°C
Nominal Sensitivity (Sn)	2	mV/V <sup>2</sup>
Nominal Input Voltage	10	V
Maximum Input Voltage	15	V
Input Impedance	400 ±20	Ω
Output Impedance	350 ±3	Ω
No Load Output	< ±2	%Sn
Insulation Resistance	> 5000	MΩ
Maximum Deflection (at Ln)	0.2-0.4	mm

<sup>1</sup> Total error: Non Linearity and Hysteresis

<sup>2</sup> Pre-corner adjustment optimized at ±0.05% by output current calibration

S  
T  
E  
L  
L  
E  
C  
T  
R  
O  
N  
I  
C  
S

# HSB

# HSB Series

**Light to Medium Capacity  
Shear Beam Load Cells**

<b>Model HSB-500KG</b>	<b>Capacity: 500 kg</b>
<b>Model HSB-1000KG</b>	<b>Capacity: 1,000 kg</b>
<b>Model HSB-2000KG</b>	<b>Capacity: 2,000 kg</b>
<b>Model HSB-5000KG</b>	<b>Capacity: 5,000 kg</b>

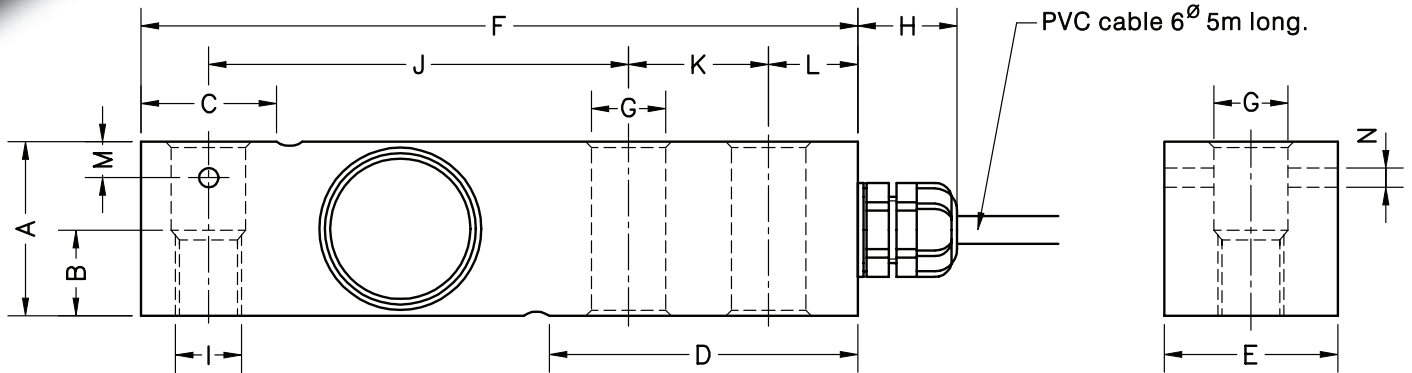

Nominal load (kg)	A	B	C	D	E	F	GØ	H	I	J	K	L	M	NØ	Transport weight
500-1000-2000	31.5	15	24.6	56	31.5	130	13.5	18	M12	76.2	25.4	15.8	6.5	3.5	0.9 kg
5000	48	-	37	76	41.5	171.5	20.5	18	20.5	95.2	38.1	19	-	-	2.2 kg

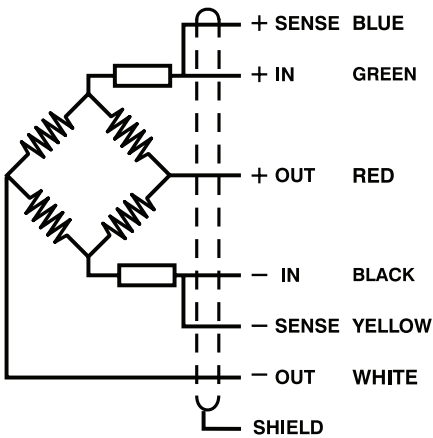

Model	Nominal Capacity	Accuracy Class	Minimum Division	Service Load	Safe Load
HSB-500KG	500 kg	3000	50 g	750 kg	1,000 kg
HSB-1000KG	1,000 kg	3000	100 g	1,500 kg	2,000 kg
HSB-2000KG	2,000 kg	3000	200 g	3,000 kg	4,000 kg
HSB-5000KG	5,000 kg	3000	500 g	7,500 kg	10,000 kg

**CERTIFICATIONS**

The HSB load cell meets all requirements of OIML R60 and has been issued OIML Certificate No. R60/2000-GB1-17.14

The HSB load cells meet all requirements of Handbook 44, issued by the National Institute of Standards of Technology and have been issued the NTEP Certificate of Conformance No. CC 17-086

Cardinal Scale reserves the right to improve, enhance or modify features and specifications without prior notice. All registered trademarks are the property of their respective owners.



102 East Daugherty St., Webb City, MO 64870 USA  
Toll-Free: (800) 441-4237 E-mail: cardinal@cardet.com  
www.CardinalScale.com

**SOLD BY:**