



LFB Series

Light to Medium Capacity Shear Beam Load Cells



- **125, 250, 500, and 1,250 kg capacities (and lb equivalents)**
- **Durable construction**
- **3 mechanical loading options**
- **OIML certified**

Cardinal Scale's 125-kg to 1,250-kg capacity LFB series shear beam load cells have a low profile design that can be mounted directly to the weighing platform. They are made specifically for light to medium weighing applications like floor scales. Their design makes them highly resistant to eccentric loads. Durable construction offers strength and the ultimate in protection for tough environments. These load cells are potted with a proprietary sealant that offers water resistance, while remaining flexible over the life of the load cell. This special compound protects the cell's strain gauges.

MECHANICAL DATA

Rated Capacity, (R.C.) E_{max}	250 lb / 125 kg 550 lb / 250 kg 1,100 lb / 550 kg 2,750 lb / 1,250 kg
Minimum Dead Load	0 lb / 0 kg
Safe Load Limit	150% R.C.
Ultimate Load	300% R.C.
Deflection at R.C.	.025 in / 0.38 mm
Spring Element Material	17-4 PH
Net Weight	1.5 lb / 0.7 kg

CERTIFICATE DATA

Issuing Body	OIML
Certificate Number	R60/1991-DK-00.02
Accuracy Class	C3
Maximum Number of Load Cell Intervals, n_{max}	3,000
Humidity Symbol	CH
Minimum Load Cell Verification Interval V_{min}	0.023, 0.046, 0.09, and 0.23 kg

ELECTRICAL DATA

Rated Output	2 mV/V
Excitation Voltage, Recommended	10 VDC
Excitation Voltage, Maximum	15 VDC
Cable Length	
LFB-250M / LFB-250P	67 in / 170 cm
LFB-500HMT	120 in / 304 cm
LFB-1000HMT	120 in / 304 cm
LFB-2500HMT	120 in / 304 cm
Terminal Resistance	
Excitation	375 - 414 ohms
Signal	350 ± 5 ohms
Zero Load Output	± 1% R.C.
Insulation Resistance	>5000 megohms at 50 VDC

ENVIRONMENTAL DATA

Temperature Compensation Range	-10° to +40°C
Operating Temperature Range	-20° to +60°C
Barometric Pressure Effect on Zero Load Output	<1 v (min)/1kPa

S
T
E
E
L
C
O
A
D
O

LFB

LFB Series

Light to Medium Capacity Shear Beam Load Cells

LFB-250M/LFB-250P

Capacity: 250 lb/125 kg

Model LFB-1000HMT

Capacity: 1,100 lb/550 kg

Model LFB-500HMT

Capacity: 550 lb/250 kg

Model LFB-2500HMT

Capacity: 2,750 lb/1,250 kg

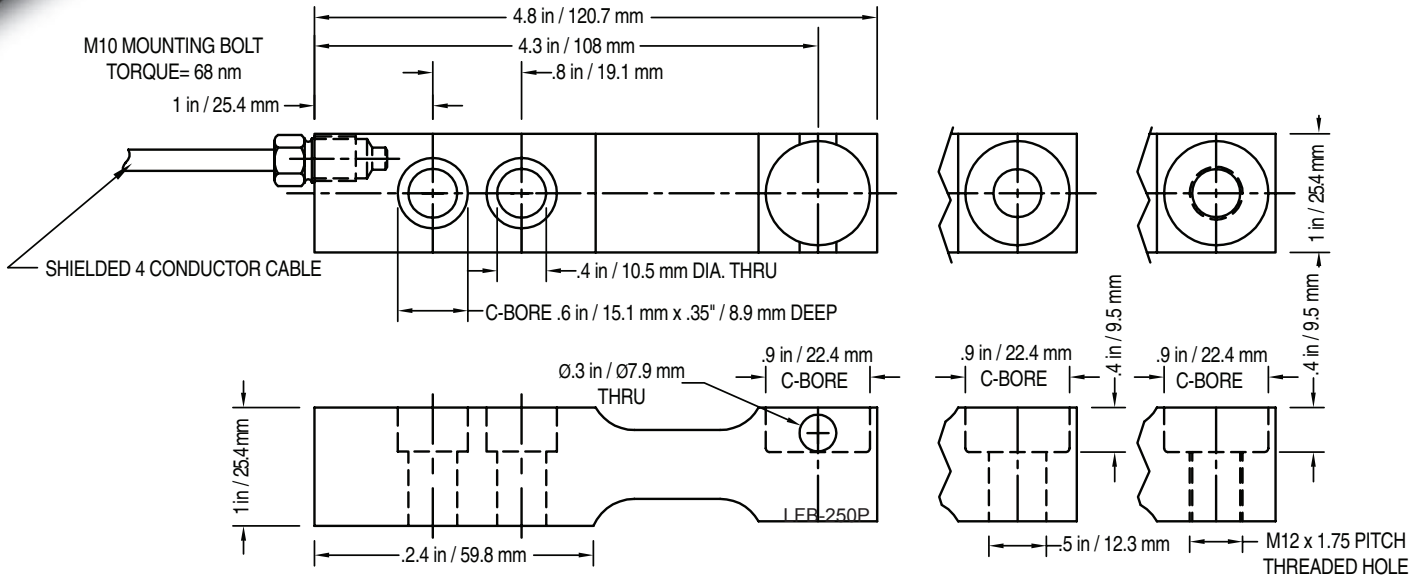

ELECTRICAL INFORMATION



State-of-the-Art Load Cell Manufacturing Facility ISO 9001 Quality Environment



CERTIFICATIONS



The LFB load cell meets all requirements of OIML R60 and has been issued OIML Certificate No. **R60/1991-DK-00.02**

VCAP CERTIFIED

Cardinal Scale has been formally audited and found to be fully compliant with the Verified Conformity Assessment Program (VCAP) administered by the National Type Evaluation Program (NTEP) of the National Conference on Weights and Measures (NCWM).

Cardinal Scale reserves the right to improve, enhance or modify features and specifications without prior notice. All registered trademarks are the property of their respective owners.



SOLD BY:



102 East Daugherty St., Webb City, MO 64870 USA
Toll-Free: (800) 441-4237 E-mail: cardinal@cardet.com
www.CardinalScale.com