



Concrete Deck Low-Profile Side Rail Truck Scales

- *Legal-for-Trade Certified up to 14 Ft.*
- *Side Rail Guidance for Driver, Truck, and Load Safety*
- *Four Different Load Cell Types Available to Choose From*



ADVANCED WEIGHBRIDGE DESIGN

WITH **MULTIPLE
LOAD CELL
TYPES
AVAILABLE**

Cardinal Scale's Olympus truck scales are engineered and manufactured for ease of shipment to job sites around the world with bolt-together installation that will provide years of reliable, accurate truckload weighing.

Cardinal Scale's Olympus truck scales bolt together for the field pouring of concrete. The 18-inch/455-mm-high I-beam, hip-style construction features a 8-inch/200-mm concrete deck (concrete not included).

The Olympus comes in choices of 6 different load cells for varying capacities with analog, digital, and hydraulic load cell offerings from Cardinal Scale. These 28-inch/70-cm-high, low-profile side rail scales are designed to minimize costs associated with delivery to job sites.

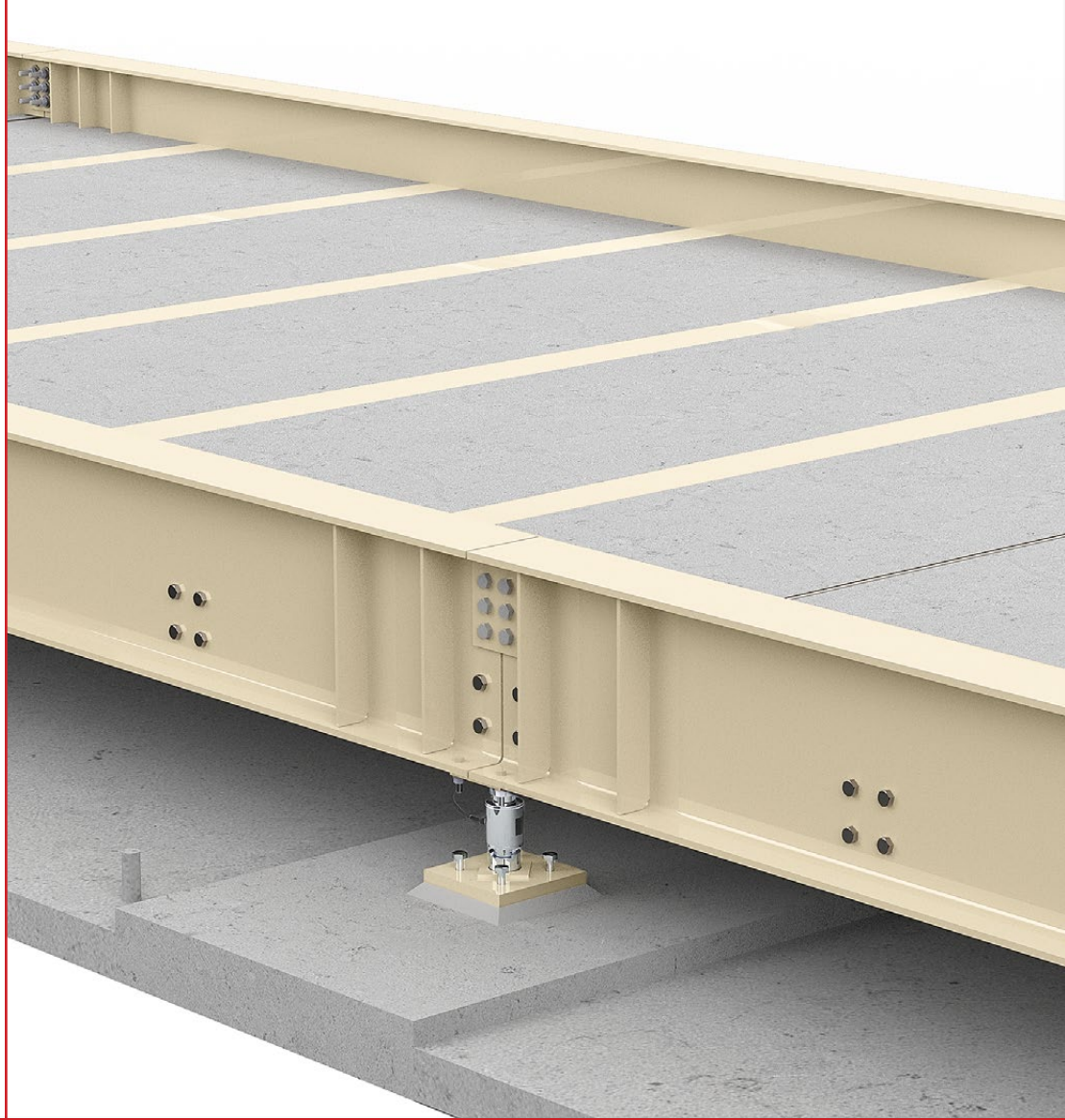

- Available with Your Choice of Analog, Digital or Hydraulic Load Cells
- Overall Scale Capacities Available Ranging from 60 Tons up to 100 Tons

- Heavyweight 30-Ton Concentrated Load Capacity (CLC)
- NTEP and OIML Certified
- Built-in I-beam Guide Rails
- 152 Different Models Available (See page 4)

- Pour-in-Place Concrete Deck Weighbridges
- Long-Lasting Baked-On Tan Powder Coat Paint

HIGH-CAPACITY VEHICLE WEIGHING

Concrete Deck Low-Profile Side Rail Truck Scales

Olympus truck scales stand up to heavy truck loads with their wide-flange I-beams utilized throughout the weighbridge that add rigidity to each side of the truck scale and serve as guide rails for safe truck loading.

All Cardinal truck scales go through an extensive 3-stage washing system at the factory, which washes the scale completely to remove all mill scale and surface imperfections. The weighbridges are then powder-coated with zinc-enriched anti-corrosion paint and baked in an industrial oven at 450° F degrees for two hours. This baked-on powder paint provides a weatherproof UV-protected finish due to the maximum coating adhesion preparation.

- NTEP and OIML Certified Widths up to 14 Ft
- Easy Access to Load Cells
- Standard 8-inch/200-mm Thick Concrete Deck



FOUR LOAD CELL TYPES AVAILABLE

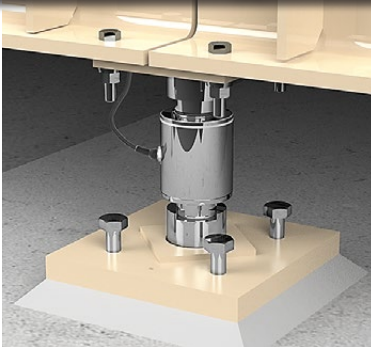

AC Series Load Cells

- Analog Compression Load Cells
- Anti-Rotation Mounting
- IP69K Waterproof Rating
- Stainless Steel Load Cells
- Stainless Steel Junction Box

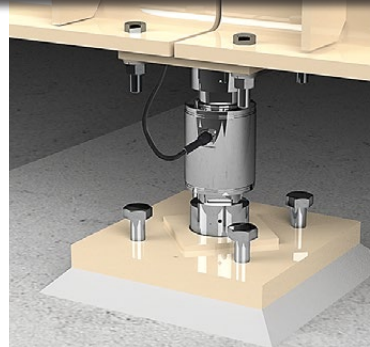

DC Series Load Cells

- SmartCell® Digital Compression Load Cells
- Anti-Rotation Mounting
- IP69K Waterproof Rating
- Stainless Steel Load Cells
- No Junction Box Necessary
- iSite Cloud-Based Remote Monitoring

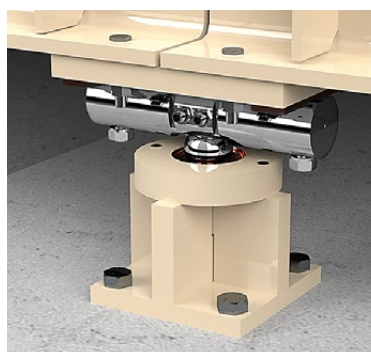

SCBD Series Load Cells

- SmartCell® Digital Double-Ended Shear Beam Load Cells
- axis® Frictionless Centering System Load Cell Stands
- IP69K Waterproof Rating
- Stainless Steel Load Cells
- No Junction Box Necessary
- iSite Cloud-Based Remote Monitoring

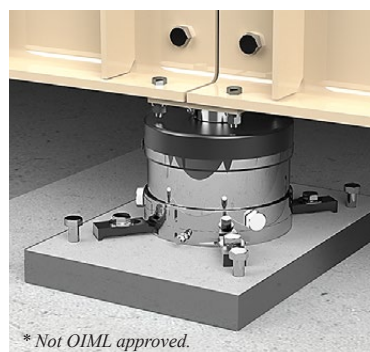

SST Series Load Cells

- Guardian® Hydraulic Compression Load Cells
- Lifetime Hydraulic Load Cell Warranty
- SST Load Cells are Immune to Water Damage, Electrical Surges and Lightning Strikes
- IP68 Waterproof Rating
- Stainless Steel Load Cells
- Severe-Duty Rated Load Cell Protection



Concrete Deck Olympus Truck Scale Models

The models listed below include the foundation kit, standard rodent protection, checking, and bolt-down anchors. Anti-corrosion industrial tan powder coat paint is standard on the weighbridges. Rebar and deck sheeting is not included.



AC-50K Analog Load Cells



Length	Capacity (tons)	CLC (tons)	No. of Bridges	WIDTH			
				10 ft.	11 ft.	12 ft.	14 ft.
10 ft.	60	30	1	1032100	1032108	1032116	1032124
20 ft.	60	30	1	1032101	1032109	1032117	1032125
40 ft.	90	30	2	1032102	1032110	1032118	1032126
47 ft.	90	30	2	1032103	1032111	1032119	1032127
60 ft.	100	30	3	1032104	1032112	1032120	1032128
70 ft.	100	30	3	1032105	1032113	1032121	1032129
80 ft.	100	30	4	1032106	1032114	1032122	1032130
100 ft.	100	30	4	1032107	1032115	1032123	1032131

AC-100K Analog Load Cells



Length	Capacity (tons)	CLC (tons)	No. of Bridges	WIDTH			
				10 ft.	11 ft.	12 ft.	14 ft.
10 ft.	60	30	1	1032150	1032158	1032166	1032174
20 ft.	60	30	1	1032151	1032159	1032167	1032175
40 ft.	90	30	2	1032152	1032160	1032168	1032176
47 ft.	90	30	2	1032153	1032161	1032169	1032177
60 ft.	100	30	3	1032154	1032162	1032170	1032178
70 ft.	100	30	3	1032155	1032163	1032171	1032179
80 ft.	100	30	4	1032156	1032164	1032172	1032180
100 ft.	100	30	4	1032157	1032165	1032173	1032181

SCBD75K Digital Load Cells



Length	Capacity (tons)	CLC (tons)	No. of Bridges	WIDTH			
				10 ft.	11 ft.	12 ft.	14 ft.
10 ft.	60	30	1	1032300	1032308	1032316	1032324
20 ft.	60	30	1	1032301	1032309	1032317	1032325
40 ft.	90	30	2	1032302	1032310	1032318	1032326
47 ft.	90	30	2	1032303	1032311	1032319	1032327
60 ft.	100	30	3	1032304	1032312	1032320	1032328
70 ft.	100	30	3	1032305	1032313	1032321	1032329
80 ft.	100	30	4	1032306	1032314	1032322	1032330
100 ft.	100	30	4	1032307	1032315	1032323	1032331

DC-50K Digital Load Cells



Length	Capacity (tons)	CLC (tons)	No. of Bridges	WIDTH			
				10 ft.	11 ft.	12 ft.	14 ft.
10 ft.	60	30	1	1032200	1032208	1032216	1032224
20 ft.	60	30	1	1032201	1032209	1032217	1032225
40 ft.	90	30	2	1032202	1032210	1032218	1032226
47 ft.	90	30	2	1032203	1032211	1032219	1032227
60 ft.	100	30	3	1032204	1032212	1032220	1032228
70 ft.	100	30	3	1032205	1032213	1032221	1032229
80 ft.	100	30	4	1032206	1032214	1032222	1032230
100 ft.	100	30	4	1032207	1032215	1032223	1032231

DC-100K Digital Load Cells



Length	Capacity (tons)	CLC (tons)	No. of Bridges	WIDTH			
				10 ft.	11 ft.	12 ft.	14 ft.
10 ft.	60	30	1	1032250	1032258	1032266	1032274
20 ft.	60	30	1	1032251	1032259	1032267	1032275
40 ft.	90	30	2	1032252	1032260	1032268	1032276
47 ft.	90	30	2	1032253	1032261	1032269	1032277
60 ft.	100	30	3	1032254	1032262	1032270	1032278
70 ft.	100	30	3	1032255	1032263	1032271	1032279
80 ft.	100	30	4	1032256	1032264	1032272	1032280
100 ft.	100	30	4	1032257	1032265	1032273	1032281

SST75 Hydraulic Load Cells

* Not OIML approved.



Length	Capacity (tons)	CLC (tons)	No. of Bridges	WIDTH			
				10 ft.	11 ft.	12 ft.	14 ft.
10 ft.	60	30	1	1032350	1032358	1032366	1032374
20 ft.	60	30	1	1032351	1032359	1032367	1032375
40 ft.	90	30	2	1032352	1032360	1032368	1032376
47 ft.	90	30	2	1032353	1032361	1032369	1032377
60 ft.	100	30	3	1032354	1032362	1032370	1032378
70 ft.	100	30	3	1032355	1032363	1032371	1032379
80 ft.	100	30	4	1032356	1032364	1032372	1032380
100 ft.	100	30	4	1032357	1032365	1032373	1032381

Options

#5 rebar
28 gauge galvanized sheeting

Cardinal Scale reserves the right to improve, enhance, or modify features and specifications without prior notice.



102 East Daugherty St., Webb City, MO 64870 USA
 Toll-Free: (800) 441-4237 E-mail: cardinal@cardet.com
 www.CardinalScale.com

SOLD BY:

