



**CARDINAL®**

# **RD2**

## **REMOTE DISPLAY**



### **Compact Size with Long Viewing Range**

- 10 levels of brightness
- 150-ft viewing range
- (1) RS232 serial port
- 2.25-inch-high LED digits
- Stainless steel wall mount or countertop bracket included
- Stainless steel enclosure
- Clear and bright weight readouts for optimal distance viewing

# RD2 REMOTE DISPLAY FOR MID-RANGE WEIGHT VIEWING APPLICATIONS



**2.25"/57mm High LED • Stainless Steel Auto-Learn Feature Selects Input Protocol RS232 Interface • 10 Levels of Brightness Compact Size • Versatile Mounting Bracket**

Whether your application necessitates monitoring weight on tanks, bins, vehicle scales or process control systems, the RD2 includes an RS-232 serial interface that is configurable to meet the communication requirements of your weight instrumentation. The rugged stainless steel enclosure is rated NEMA4/IP66 for added protection from water and dust inherent in industrial environments.

- Display**..... Six-digit, seven-segment, 2.25" / 57 mm high LED
- Power**..... 94 to 264 VAC, 47/63 Hz  
Universal Input
- Annunciators**..... lb, kg, T, t, G, N
- Interface**..... 20mA current loop, RS-232
- Display Capacity**..... -99999 to 999999
- Enclosure**..... Stainless steel
- Enclosure Rating**..... IP66
- Viewing Range**..... 150' / 46 m
- Operating Temp**..... -10 to 120° F (-23 to +49° C)
- Shipping Weight**..... 16 lb / 7.3 kg

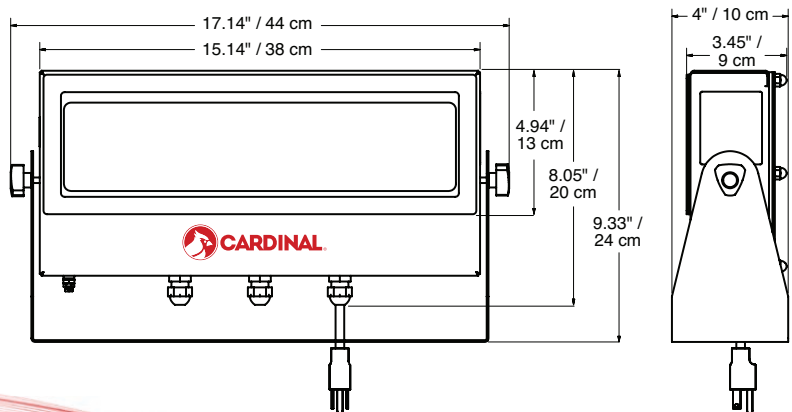

## RD2X4 QUAD REMOTE DISPLAY

- Displays steering, drive, and trailer axles plus total weight
- Dimensions: 16.7 in W x 26.8 in H x 7.9 in D / 42 cm W x 68 cm H x 20 cm D
- IP66 mild steel painted industrial tan with rain hood
- (4) Six-digit, seven-segment, 2.25-in / 57-mm-high digits LED
- 150-ft viewing range
- 10 brightness level settings

Cardinal Scale's RD2X4 quad remote display provides readouts for multi-platform truck scales visible up to 150 feet away. This display is designed for truck weighing systems where the steering axle, drive axle, trailer axle, and total weight are shown to the truck driver. The IP66-rated steel cabinet features a rain hood and is painted industrial tan for long-lasting outdoor use. The cabinet comes with a post mount designed for 4-inch pipe (approx. 4.5-in OD).



102 East Daugherty St., Webb City, MO 64870 USA  
 Toll-Free: (800) 441-4237 E-mail: cardinal@cardet.com  
 www.CardinalScale.com

**SOLD BY:**

