



SB Series

Shear Beam Medium to Heavy Capacity Load Cells



- Welded cup for superior protection
- Environmentally-sealed (IP68)
- Stainless steel construction
- NTEP and OIML certified

Cardinal Scale's SB series shear beam load cells are ideal for low profile platform scales, tank/hopper weighing, and other process control systems. These load cells are fabricated from stainless steel to provide the ultimate in protection when caustic or wet environments are encountered. Provided with the SB load cell are mounting holes for securing the cell. Each load cell is furnished with a 20-ft/6-m integral multiconductor cable secured by strain relief seal. Capacities available from 2,500 lb/1,130 kg to 20,000 lb/9,000 kg.

MECHANICAL DATA

Rated Capacity, (R.C.) E _{max}	2,500 lb / 1,130 kg 5,000 lb / 2,260 kg 10,000 lb / 4,500 kg 20,000 lb / 9,000 kg
Minimum Dead Load	0 lb / 0 kg
Safe Load Limit	150% R.C.
Ultimate Load	300% R.C.
Deflection at R.C.	1.5-.04 in / 38-.97 mm
Spring Element Material	17-4 PH
Net Weights	5 lb / 2 kg - 10 lb / 5 kg

ELECTRICAL DATA

Rated Output	2mV/V ± 0.1%
Excitation Voltage, Recommended	10 VDC
Excitation Voltage, Maximum	15 VDC
Cable Length	20 ft / 6 m
Terminal Resistance	
Excitation	386 ± 20 ohms
Signal	350 ± 5 ohms
Zero Load Output	± 1% R.C.
Insulation Resistance	>5000 megohms at 50 VDC

CERTIFICATE DATA

Issuing Body	NTEP	OIML
Certificate Number	87-059	R60/1991-DK-97.02
Accuracy Class	III/IIIL	C3
Maximum Number of Load Cell Intervals, n _{max}	5,000/10,000	3,000
Single/Multiple	S/M	
Humidity Symbol		CH
Minimum Load Cell Verification Interval V _{min}	III 0.16, 0.32, 0.64 & 1.27 kg IIIL 0.1, 0.2, 0.4 & 0.8 kg	0.086, 0.17, 0.35 & 0.70 kg

ENVIRONMENTAL DATA

Temperature Compensation Range	-10½° to +40½°C
Operating Temperature Range	-29½° to +93½°C
Construction & Protection Code	CP-67 HU, IP68
Barometric Pressure Effect on Zero Load Output	<1 v (min)/1kPa

SHEAR BEAM

SB

SB Series | Medium to Heavy Capacity

Shear Beam LOAD CELLS

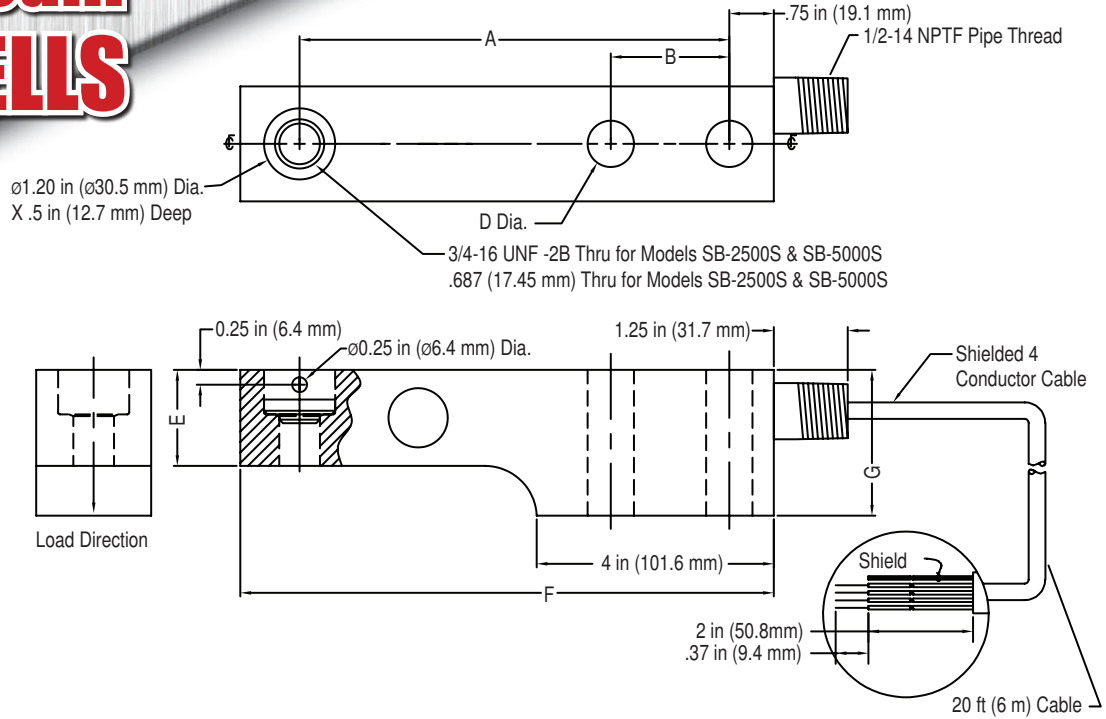

MODEL	CAPACITY	"A"	"B"	"C"	"D"	"E"	"F"	"G"
SB-2500S	2,500 lb / 1,130 kg	6.375 in / 161.9 mm	2.50 in / 63.5 mm	1.45 in / 36.8 mm	.531 in / 13.51 mm Dia. Thru	1.25 in / 31.7 mm	8.00 in / 203.2 mm	1.94 in / 49.2 mm
SB-5000S	5,000 lb / 2,260 kg	6.375 in / 161.9 mm	2.50 in / 63.5 mm	1.45 in / 36.8 mm	.531 in / 13.51 mm Dia. Thru	1.43 in / 36.3 mm	8.00 in / 203.2 mm	1.94 in / 49.2 mm
SB-10000S	10,000 lb / 4,500 kg	7.250 in / 184.2 mm	2.00 in / 50.8 mm	1.94 in / 49.3 mm	.781 in / 19.83 mm Dia. Thru	1.62 in / 41.1 mm	9.00 in / 228.6 mm	2.46 in / 62.5 mm
SB-20000S	20,000 lb / 9,000 kg	7.250 in / 184.2 mm	2.00 in / 50.8 mm	1.94 in / 49.3 mm	.781 in / 19.83 mm Dia. Thru	2.00 in / 50.8 mm	9.00 in / 228.6 mm	2.46 in / 62.5 mm

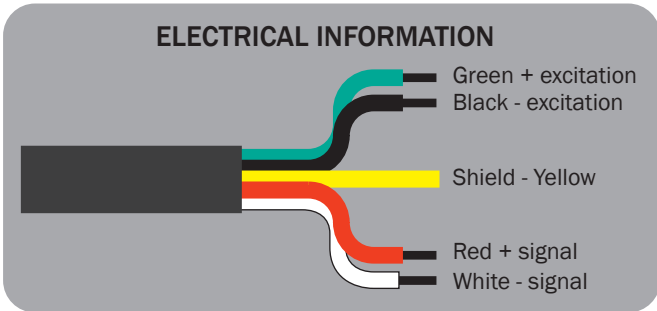

State-of-the-Art Load Cell Manufacturing Facility ISO 9001 Quality Environment



CERTIFICATIONS



The SB shear beam load cell meets all requirements of OIML R60 and has been issued OIML Certificate No. **R60/1991-DK-97.02**



The SB shear beam load cell meets all requirements of Handbook 44, issued by the National Institute of Standards and Technology and have been issued the NTEP Certificate of Conformance No. **87-059**.

VCAP CERTIFIED

Cardinal Scale has been formally audited and found to be fully compliant with the Verified Conformity Assessment Program (VCAP) administered by the National Type Evaluation Program (NTEP) of the National Conference on Weights and Measures (NCWM).

Cardinal Scale reserves the right to improve, enhance or modify features and specifications without prior notice. All registered trademarks are the property of their respective owners.



SOLD BY:



102 East Daugherty St., Webb City, MO 64870 USA
 Toll-Free: (800) 441-4237 E-mail: cardinal@cardet.com
 www.CardinalScale.com