

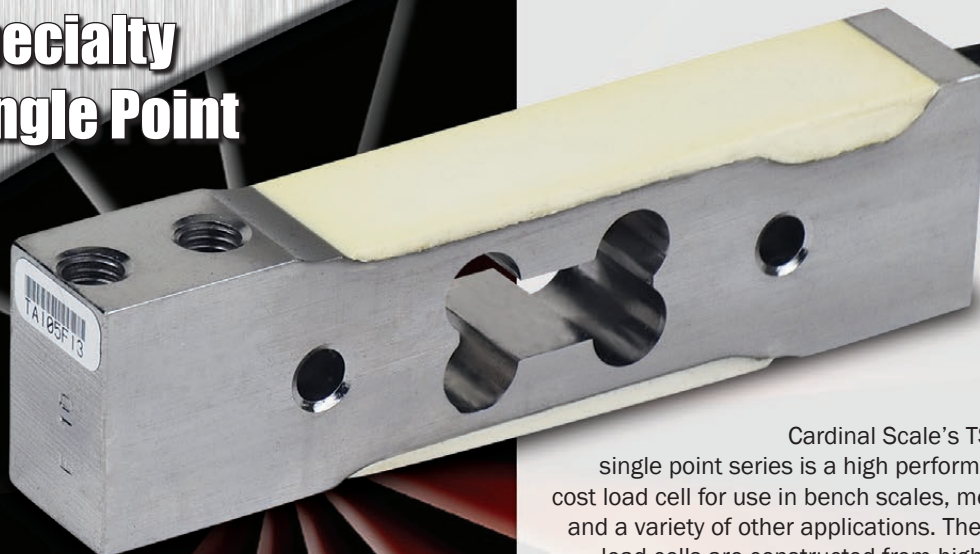

TSSP Series

Load Cells for Bench Applications

Specialty Single Point



- 45 to 507 lb capacities available
- Moisture-proof barrier protection
- Stainless steel construction

Cardinal Scale's TSSP specialty single point series is a high performance and low cost load cell for use in bench scales, medical scales, and a variety of other applications. These low-profile load cells are constructed from high-grade (17-4) stainless steel and are easy to install. Available in capacities ranging from 45 to 507 lb / 20 to 230 kg, they feature integral mounting boss. All critical components and wiring are encapsulated to protect against moisture and to insure stable operation of the TSSP in harsh environments. OIML certified.

MECHANICAL DATA

Rated Capacity, (R.C.) E_{max}	45 lb / 20 kg, 110 lb / 50 kg, 160 lb / 75 kg, 220 lb / 100 kg 440 lb / 200 kg (200kg wide) 507 lb / 230 kg
Minimum Dead Load	4.4 lb / 2 kg
Safe Load Limit	150% R.C.
Ultimate Load	300% R.C.
Deflection at R.C.	.008 in / 0.2 mm
Net Weight	1.97 lb / .9 kg

CERTIFICATE DATA

Issuing Body	OIML
Certificate Number	R60/2000-NL1-04.20
Accuracy Class	C3
Maximum Number of Load Cell Intervals, n_{max}	3,000
Single/Multiple	S
Minimum Load Cell Verification Interval V_{min}	.1 oz / 2.8 g, .2 oz / 7 g, .3 oz / 10 g, 1 oz / 28 g

ELECTRICAL DATA

Rated Output	2±10.0% mV/V
Excitation Voltage, Minimum	12 VDC
Excitation Voltage, Maximum	20 VDC
Cable Length	10 ft / 3 m
Terminal Resistance	
Excitation	435 ±10 ohms
Signal	350 ±5 ohms
Zero Load Output	±1% R.C.
Insulation Resistance	>5000 megohms at 50 VDC

ENVIRONMENTAL DATA

Temperature Compensation Range	-10 to +40°C
Operating Temperature Range	-25 to +50°C
Construction & Protection Code	IP65
Barometric Pressure Effect on Zero Load Output	<1 v (min)/1kPa

TSSP

TSSP Series

Specialty Single Point Load Cells for Bench Applications

Models Available:
TSSP-20KG, TSSP-50KG
TSSP-75KG, TSSP-100KG
TSSP-230KG, TSSP-200KGW

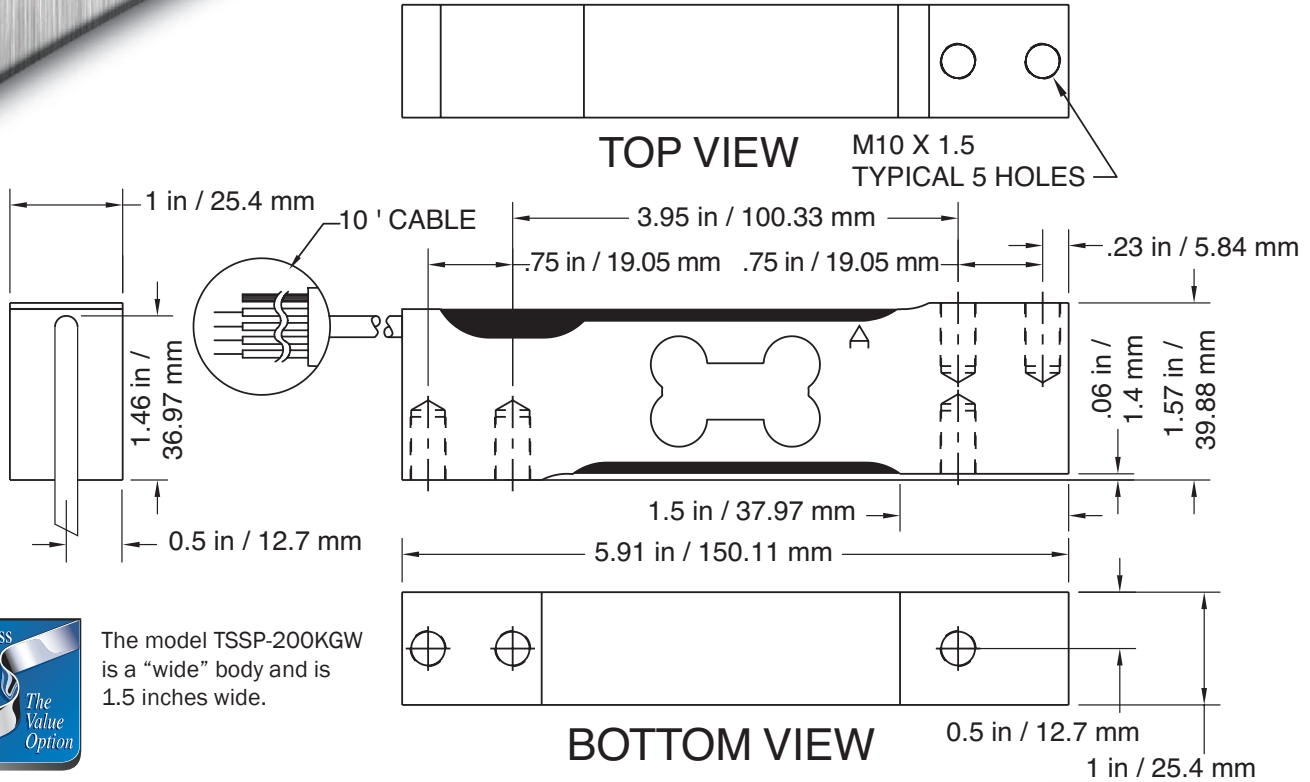

The model TSSP-200KGW is a "wide" body and is 1.5 inches wide.

ELECTRICAL INFORMATION



State-of-the-Art Load Cell Manufacturing Facility ISO 9001 Quality Environment



CERTIFICATIONS



Certificate of
Conformance Number
R60/2000-NL1-04.20

VCAP CERTIFIED

Cardinal Scale has been formally audited and found to be fully compliant with the Verified Conformity Assessment Program (VCAP) administered by the National Type Evaluation Program (NTEP) of the National Conference on Weights and Measures (NCWM).

Cardinal Scale reserves the right to improve, enhance or modify features and specifications without prior notice. All registered trademarks are the property of their respective owners.



SOLD BY:



102 East Daugherty St., Webb City, MO 64870 USA
 Toll-Free: (800) 441-4237 E-mail: cardinal@cardet.com
 www.CardinalScale.com